

Feed-in Tariffs

ROO-FIT Accreditation

www.ofgem.gov.uk

May 2017

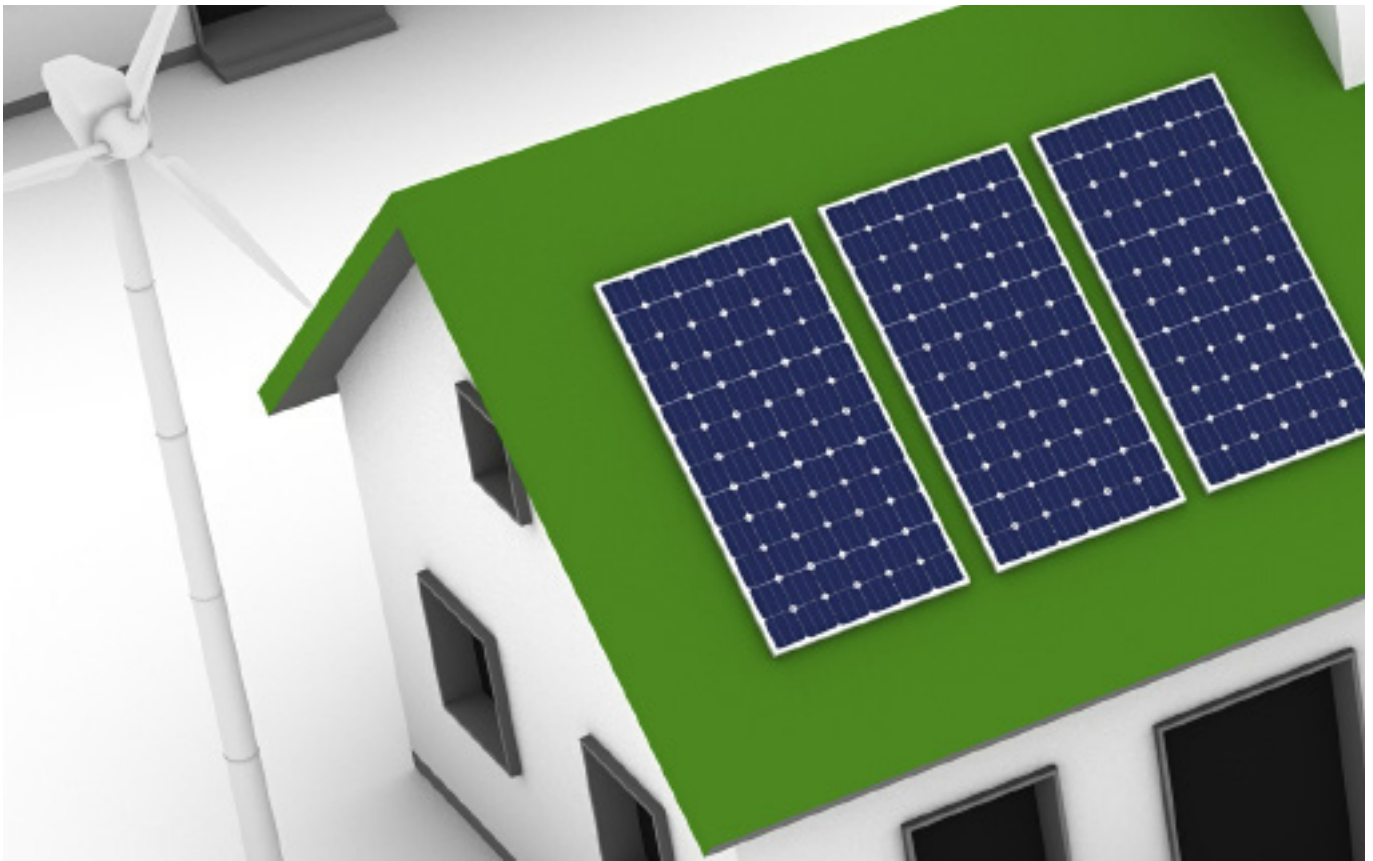

Essential Guide to applying for ROO-FIT accreditation

Support and information for applicants

About this guide

The following advice can help you avoid common mistakes when submitting your ROO-FIT application.

Giving us the right information reduces the risk of delays to your application and Feed-in Tariffs (FIT) payments.

This guide will help you apply for support under the Feed-in Tariffs (FIT) scheme using the ROO-FIT accreditation process.

This document provides a simple overview of:

- The 'full accreditation' application process and what it requires.
- How to make sure your application is right first time, including examples of common issues with applications.
- What your responsibilities are as an applicant.
- What you can expect from Ofgem's ROO-FIT team.
- How to set up an account on Ofgem's Renewable and CHP Register and pinpoint the accreditation route that's best for you.

This is not a definitive legal guide and is not a substitute for getting your own independent legal or technical advice. For more detailed information, we encourage you to read the 'Feed-in Tariffs: Guidance for renewable installations' available at: www.ofgem.gov.uk/environmental-programmes/fit.

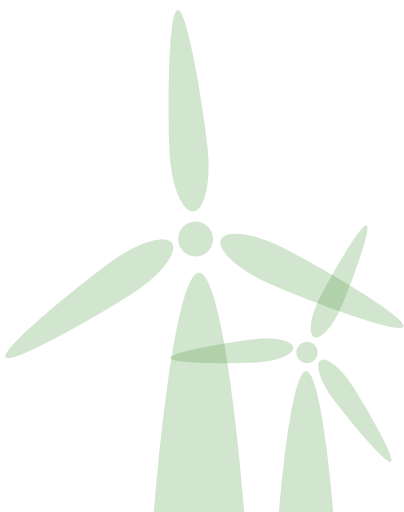

How to get FIT accreditation

This section is a brief overview of the accreditation process. For more information on the route of accreditation that's right for you, please see the later section.

To be eligible for the FIT scheme the Total Installed Capacity (TIC) of an installation must not exceed 5MW (2kW limit in the case of micro Combined Heat and Power (CHP)). Eligible installation types are:

- **Solar photovoltaic (Solar PV)**
- **Wind**
- **Hydro**
- **Anaerobic Digestion (AD)**
- **Micro CHP**

You can apply for FIT support through one of two routes depending on the size and type of your installation:

- 1 MCS-FIT accreditation – for PV and wind installations with a Declared Net Capacity (DNC) up to and including 50kW and micro CHP installations with a DNC up to and including 2kW. It may help you to know that the average home-scale PV installation is 4kW. This is the application route for smaller installations. To apply for this route of accreditation:

Commission your installation

You must use an MCS-certified installer using MCS-certified equipment. Your installer will register your installation on the central MCS database and give you an MCS certificate.

Choose a FIT licensee

A full list of FIT licensees is available on our website www.ofgem.gov.uk/environmental-programmes/fit

Complete an application form

Contact your chosen FIT licensee to request an application form or complete an application form online.

Return the form to your FIT licensee along with your MCS certificate. For solar PV installations, an Energy Performance Certificate (EPC) rated D or better must also be provided. Your EPC must have been issued before the commissioning date of your installation.

Claim FIT payments

Once your FIT licensee grants the accreditation, they will make FIT payments to you once a quarter.



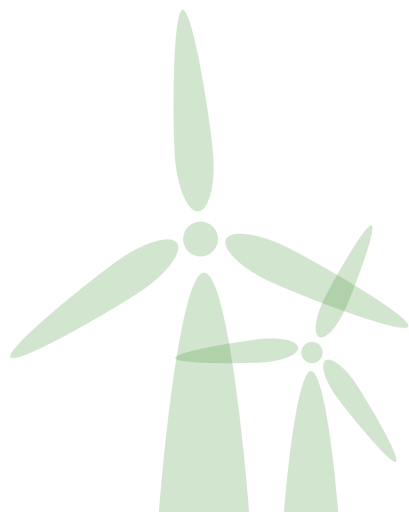

2 ROO-FIT accreditation – for PV and wind installations with a DNC greater than 50kW up to and including 5MW and all AD and hydro installations up to and including 5MW. To apply for this route of accreditation:

Set up an account

Set up an account on the Renewables and CHP Register. The account must be set up by the owner (or prospective owner for FIT preliminary accreditation applications) of the installation or a suitable representative from within the company who owns (or will own) the installation. This individual will become the account superuser. More information on this can be found later in this guide.

Start an application form

Start a new application by clicking 'Accreditation' and then 'Apply for a New Accreditation'.

Select application type

There are two application types - Full ROO-FIT accreditation and FIT preliminary accreditation. More information can be found in the 'Which application route is right for you?' section. The application starts at the same place for both types of accreditation, but different questions will be asked.

Submit

Complete and submit the application. Make sure that the superuser of the account agrees all declarations. For the purpose of caps, the application will be classed as received by us once the 'send' option has been selected.

Ofgem confirms receipt

We will send an email to the superuser to confirm that we have received your application (usually within one working day of receiving it). If your installation will be considered for entry into the current tariff period we will contact you to confirm within 10 working days. If your application is not in the current tariff period it will take its place in the queue. You won't hear from us again until we write to confirm which tariff period your installation is in. This will happen within 10 working days of the start of the relevant tariff period that the installation is being considered for entry for.

Ofgem review

The application will go through two or three stages of review depending on the complexity of the application. Based on our experience of administering the scheme to date, if your application is right first time it should take less than 12 weeks to approve. If the application is not right first time and we have to ask questions, it will take longer.

You will have to provide evidence to support your application. See 'The application form' section for more.

We may ask you questions about your application. See the 'Your responsibilities section' for more.

Application success

If successfully accredited, confirmation of your accreditation will be sent to you by email.

Claim FIT payments

Once accreditation is granted, approach your chosen FIT licensee who will make FIT payments. A [full list of FIT licensees](#) is available on our website: www.ofgem.gov.uk/environmental-programmes/fit

✓ TOP TIP:

We publish a full list of applications queued for deployment caps in the [deployment caps reports section of our website](#). You can use the reports to see where your installation is in the queue compared to other applications. The queue may change over time so please keep checking our website for an up-to-date indication of your place in the queue. More information on deployment caps can be found later in this guide.

Creating an account on the Renewables and CHP Register

This section shows you how to set up an account on the 'Renewables and CHP Register'. This is the Register you will use to submit your ROO-FIT application and respond to any queries from us. Our guide [How to create an account on the Renewables and CHP Register](#) provides a more in-depth guide to this process.

- 1 Go to www.renewablesandchp.ofgem.gov.uk
- 2 From the home page, click on the 'Register' button and then click 'continue'.
- 3 You will be given a choice of four different accounts. Make sure you choose a generator account and click submit.
- 4 The next screen will show 'Organisation Type' and 'Generator Organisation' options. Make sure you choose the organisation type that is applicable to you. Choose the 'Individual' option if you are applying under your own name, the 'Company' option if you are applying under a limited company name and the 'Other' option if you are a business but aren't a limited company such as a partnership/charity.



TOP TIP:

Before you go any further, applications for full ROO-FIT accreditation must be submitted by the owner of the installation. If you are not the owner of the installation, you must get the owner to create an account. Later, they can then add you as an additional user on their account. You will then be able to complete administrative tasks on their behalf. Unfortunately, we cannot discuss any account/application issues with anyone who is not a named user on the account.

- 5 Once you have filled in all the details, click on 'Add generator organisation'.



TOP TIP:

The first line of the address provided in your account must match exactly with the Royal Mail Database. You can check this by entering your postcode into the 'Royal Mail Postcode Finder' www.royalmail.com/postcode-finder. If the address is not registered with Royal Mail, you must get it registered. You can do this while your application is being processed, or use a registered address instead.

- 6 Enter the details of an authorised signatory for the account. This person will become the superuser of the account. The superuser MUST be the owner (or prospective owner for FIT preliminary accreditation applications) of the installation or a suitable representative from within the company who owns (or will own) the installation.



Creating an account on
the Renewables and
CHP Register

- 7 If you are registering as a company you must submit a letter of authorisation. This must be completed on company headed paper and signed by an authorised signatory for the company. For a letter template, contact the ROO-FIT team (see details at the end of this document).

- 8 Once you have completed the required details, click 'Confirm' and your registration will be complete. You will receive an automated email confirming your username. Within one working day we will approve the account or request further information. Once the account has been approved you will receive an email containing the password. Please contact the ROO-FIT team (see details at the end of this document) if you do not receive an email.

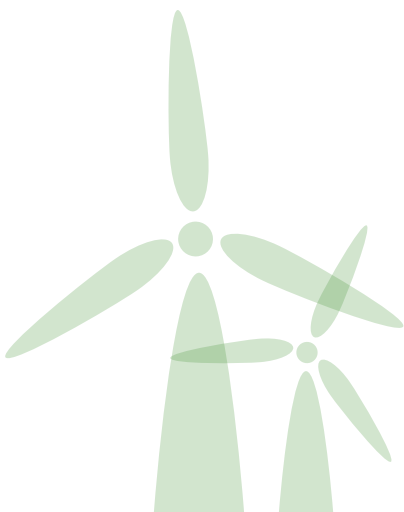

Which application route is right for you?

There are two types of application that can be submitted using the ROO-FIT accreditation process:

1 Full accreditation:

- A. For installations which have been commissioned.
- B. For installations which have been granted preliminary accreditation and have been commissioned or are due to be commissioned in the next two months (known as 'Convert to Full' applications).

2

Preliminary accreditation:

- A. For proposed installations yet to be commissioned.
- B. Available if your installation is entitled to use the ROO-FIT accreditation process.



TOP TIP:

The benefits of obtaining preliminary accreditation include:

- 1 a guaranteed tariff, and
- 2 assurance that your installation will be eligible to receive FIT support once commissioned subject to certain conditions.

Separate guidance on preliminary accreditation is also available.



TOP TIP:

To apply for full accreditation (without first seeking preliminary accreditation) the installation must have commissioned on or before the date the application is submitted to Ofgem. If the installation is not commissioned, the application will be refused and the place in the deployment cap queue will be forfeited.



Which application route is right for you?

Which type of ROO-FIT application is right for you - Full or FIT preliminary accreditation?

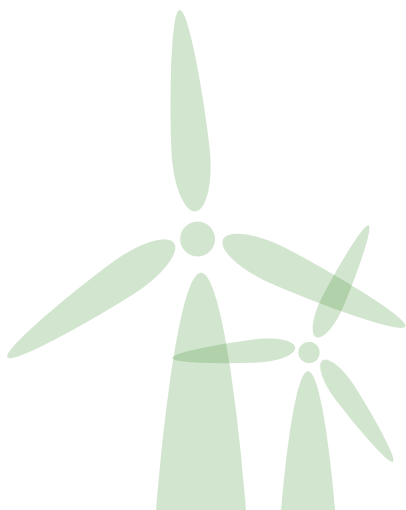
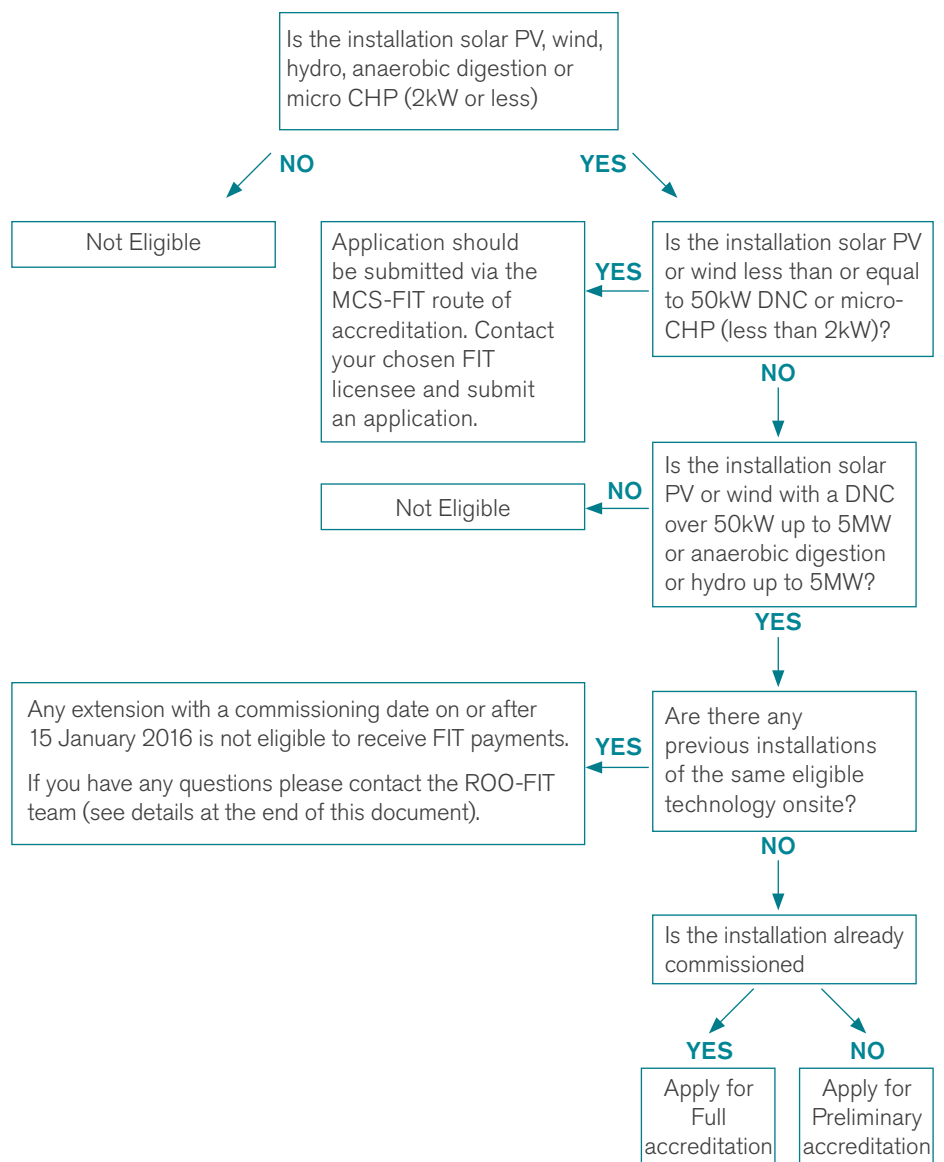

Deployment Caps

On 8 February 2016 a capped queueing system was introduced into the FIT scheme to limit the aggregate capacity that can receive the FIT tariff available in a particular tariff period.

Separate deployment caps are available for each technology and tariff band and are set for a three month period, with the exception of micro CHP that are set for a six month period.

FIT tariffs are adjusted at the beginning of each tariff period through a process called 'degression'.

ROO-FIT applications are queued based on the date and time you click 'send' when making your application. Once a deployment cap is filled, no further installations can receive the tariff rate that applied for that tariff period.

Deployment Caps:

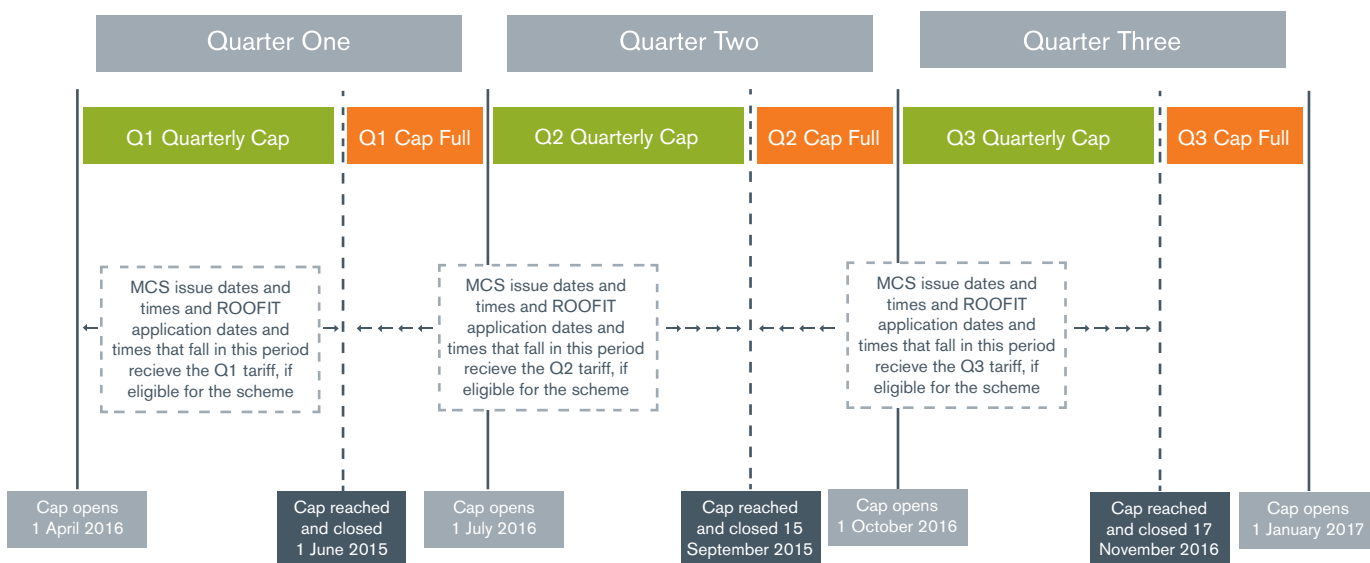

This diagram illustrates how the deployment caps mechanism will work in practice for quarterly tariff periods. The dates at which caps are reached are examples only.



The application form

This is an overview of the key questions on the ROO-FIT full accreditation application form. There's also guidance on how to complete the application form right first time and the types of additional evidence we will ask for.

Generating station name (QA100)

You can name your installation anything you like. Make sure you call it something you can remember. Once you have chosen a name it **cannot** be changed. The name of your generating station will be used as the reference for your application and you will need to use it if you contact us.

Commissioned date (QA201)

This is the date your installation was first capable of operation once all commissioning tests were complete. Take a look at the 'Feed-in Tariffs': Commissioned guide' for a more detailed explanation. An application for full ROO-FIT accreditation submitted on or after 15 January 2016 must relate to an installation that was commissioned before the application was made. We will need independent verification that the installation has been commissioned. You can do this by providing the following documents, at a minimum:

Installation Type	Minimum Requirement
Not grid connected	<ul style="list-style-type: none">▪ a signed commissioning certificate and/or▪ a letter from your installer confirming the commissioned date
Grid connected (G59 test witnessed)	<ul style="list-style-type: none">▪ a copy of the G59 test certificate signed by the testing engineer and a witness from the distribution network operator (DNO)▪ a signed copy of the commissioning certificate
Grid connected (G59 test not witnessed)	<ul style="list-style-type: none">▪ written confirmation from the DNO that they did not need to witness the test▪ a copy of the G59 test certificate signed by the testing engineer▪ a signed copy of the commissioning certificate



TOP TIP:

The commissioned date entered for question QA201 must match the commissioning date in the capacity table question QC237. If they do not match, we will ask you to correct it, which will delay the application.



TOP TIP:

The G59 test certificate and commissioning certificate must state the date the testing took place and make reference to the installation name or address.

The remainder of this essential guide is for applicants seeking ROO-FIT full accreditation.

A separate guide for the preliminary route of ROO-FIT accreditation is available.



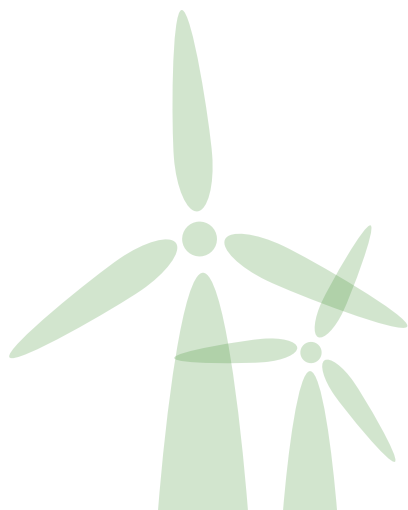

Total Installed Capacity (TIC) and Declared Net Capacity (DNC) (QA301 and QA401)

TIC is the maximum capacity that the installation can operate for a sustained period without damaging it. It is important because it is used to set the FIT generation tariff.

DNC is the maximum capacity that the installation could be operated, minus any electricity needed to operate the installation – such as any electricity used to move the head of a wind turbine in and out of the wind.

The following table explains how to calculate TIC and DNC and the minimum evidence that we will require.

The table is not exhaustive. Keep in mind how TIC and DNC are defined in the FIT legislation (available in the 'Feed-in Tariffs: Guidance for renewable installations') when submitting an application. We may ask for more information in certain circumstances, such as where the TIC is limited to below the manufactured capacity.

If an installation's TIC is close to a tariff boundary, we will probably need you to submit metered data to confirm that the installation has not operated in excess of the declared figure.

- ✓ **TOP TIP:**
DNC is almost always less than the TIC because all installations will consume some electricity during start-up or operation. Your installer will be able to help you work out the amount of electricity your installation consumes. This should be subtracted from the TIC.
- ✓ **TOP TIP:**
We cannot accept Word documents as evidence. Please provide scanned copies of signed original documents.
- ✓ **TOP TIP:**
The TIC stated in the application must be the TIC that the installation is capable of operating at on the commissioned date. It must not be the intended TIC if capacity is to be added later.
- ✓ **TOP TIP:**
For full accreditation applications submitted on or after 15 January 2016 the TIC cannot be changed after the application is submitted. Any changes to the TIC may result in the application being refused.

Technology	How to calculate TIC	How to calculate DNC	Required evidence
PV	Multiply the number of panels installed by the rated peak power output of the panels. For example, an installation comprising 1000 panels of 250 watts would have a TIC of 250kW.	The DNC should reflect the TIC, minus any power consumed by the installation to run its auxiliaries during operation. In most cases this will be the capacity of the inverters. Contact your installer if you are unsure of this figure.	A certificate or letter signed by the installer confirming the TIC and listing the number and capacity of panels.
Wind	Wind turbines may be sold stating a lower capacity than the maximum it can operate. Refer to the turbine manufacturer's published power curve. The maximum generation data point should be given as the TIC.	The DNC should reflect the TIC, minus any power consumed by the turbine to run its auxiliaries. Your installer can help you provide this information.	A certificate or letter signed by the installer confirming the TIC and DNC.
Hydro	The TIC of a hydro can be calculated in a number of ways. Most simply it is the maximum continuous rating (MCR) of the generator. If you wish to state a TIC which is different to this, please provide an explanation from the installer. This should reference the definition of TIC stated in the FIT legislation.	The DNC should reflect the TIC, minus any power consumed by the installation to run its auxiliaries. Your installer can help you provide this information.	A certificate or letter signed by the installer confirming the TIC. If this is different to the MCR of the generator, it should include an explanation of the TIC with reference to the definition.
AD	The TIC of an AD installation is the maximum continuous rating (MCR) of the engine.	The DNC should reflect the TIC, minus any power consumed by the installation to run its auxiliaries. Power used in the anaerobic digestion process is not considered an installation auxiliary.	A certificate or letter from the installer confirming the MCR of the engine.

The application form



Location: Address, postcode and OS grid reference (QA206 and QB300)

The installation address and OS grid reference should refer to the location of the installation's connection to the grid (normally the Meter Point Administration Number or MPAN).

The OS grid reference should use two letters followed by the first three figures of each five figure sequence that follow these letters. For example, for point AB 01234 56789, the grid reference would be AB012567.

You can find your OS grid reference on the UK Grid Reference Finder website: www.gridreferencefinder.com



TOP TIP:

The postcode and OS grid reference must refer to the same location (or be close together). If they do not, this will be questioned and will delay the application.

Do you want to apply for the Feed-in Tariffs (FIT) scheme, the Renewables Obligation (RO) scheme or none of the above? (QC100)

You can apply for a number of schemes using the same application form. If you wish to apply for support under the FIT scheme (full accreditation or preliminary accreditation) then state 'Feed-in Tariffs'.

Reusing generating equipment (QC130)

If any part of your installation is refurbished, second-hand or has been used previously at a different location, you must answer 'yes' to this question. You will then be asked to provide information about the origin of the generating equipment.

To read more about how we define 'generating equipment', please refer to the 'Feed-in Tariffs "Generating equipment" decision' on our website: www.ofgem.gov.uk/environmental-programmes/fit

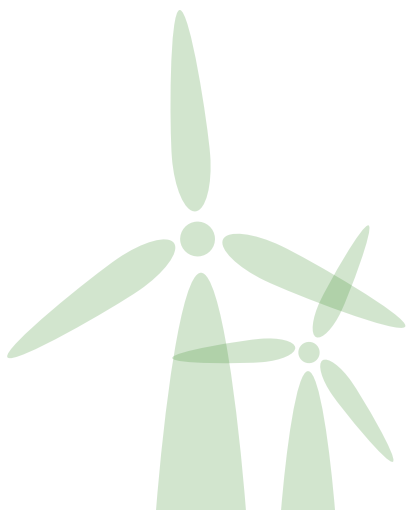

Are there any previous installations of this technology operating on this site? (QC140)

If you have an installation of the same technology installed on the site that is **not** currently receiving support under the FIT scheme, you should say 'yes' to this question. We will then ask you some additional questions about the capacity of that previous installation.

If you have an installation of the same technology already commissioned on the site and accredited following the MCS-FIT route of accreditation, please answer 'No' to this question. Instead, in QE100 please provide a full description of the whole installation including the FIT accreditation number(s) of capacity that is already accredited. The existing capacity should also be clearly shown on the schematic diagram (see below for more information on schematic diagrams).

Please note, extensions (added capacity of the same technology) which commissioned on or after 15 January 2016 are not eligible to receive FIT support.

Grants (QC150)

If you have accepted an offer of a grant from public funds for the cost of purchasing or installing your installation and you have not repaid the grant, the installation will not be eligible for FIT support.

If you are unsure whether your grant is from public funds or whether it was made for purchasing or installing the installation, answer 'yes' to this question and we will help identify whether or not this will affect you.



TOP TIP:

If in doubt, declare the grant and we will help work out whether the grant affects entitlement to FIT payments

The application form



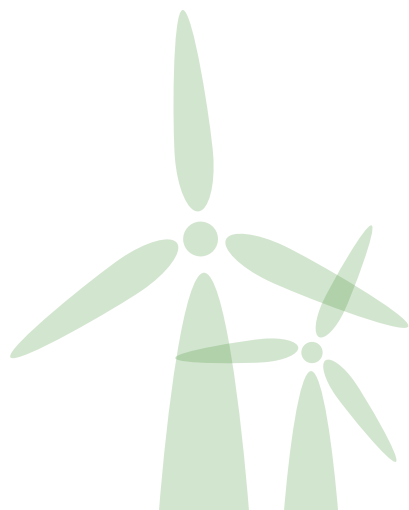

Metering requirements (various questions)

MPANs

A supply MPAN (Meter Point Administration Number) is a unique identifying number for your electricity import meter. You can find your supply MPAN on your electricity bill or by contacting your electricity supplier. An import MPAN contains 13 digits.

An export MPAN is a unique identifying number for the electricity export meter. Your electricity supplier will be able to provide you with an export MPAN if you have an export meter. An export MPAN contains 13 digits. Your supply and export MPANs will not match.

Metering

To claim the FIT generation tariff you must have an approved generation meter installed.

Installations with a TIC greater than 30kW that want to claim the FIT export tariff must have an approved export meter. It is possible to 'deem' export payments for installations with a TIC of 30 kW or less.

This table explains where the relevant meters should be located:

Meter	Purpose	Location
Generation Meter	Measures the quantity of electricity generated by the installation. You may have more than one generation meter.	After the point of generation.
Export Meter	Measures the quantity of electricity exported onto the grid.	At the point where electricity is exported onto the grid.
Import Meter	Measures the quantity of electricity that is imported from your electricity supply.	At the point where electricity is imported from the grid.



TOP TIP:

An export meter (located as described above) can be used to claim FIT generation payments and export payments.

Meter details

We need to know the make, model and serial number of each meter at the installation. These details should be visible on the meter. Your installer should be able to help you find these details.

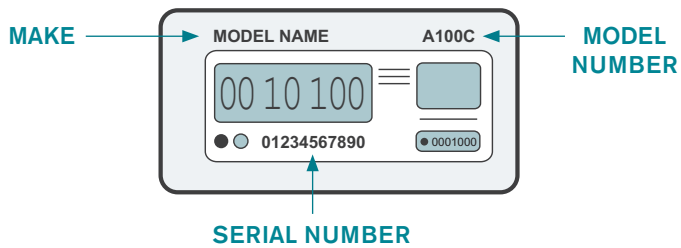

TOP TIP:
If in doubt, send a photograph of your meter(s) to the ROO-FIT team (see details at the end of this document) and we will help you identify the relevant details.

Meter readings

For all meters that will be used to claim FIT payments, you must provide start meter readings taken on or after your 'eligibility date' – this is the date FIT payments will start.

We cannot accept estimated meter readings.

TOP TIP:
You should take regular meter readings until your 'eligibility date' has been confirmed. Once this has happened we may ask you to update the meter reading in the application.

TOP TIP:
If you do not include meter readings taken on or after the correct date we will ask you to amend your application. This will delay the application process.

The application form



The application form

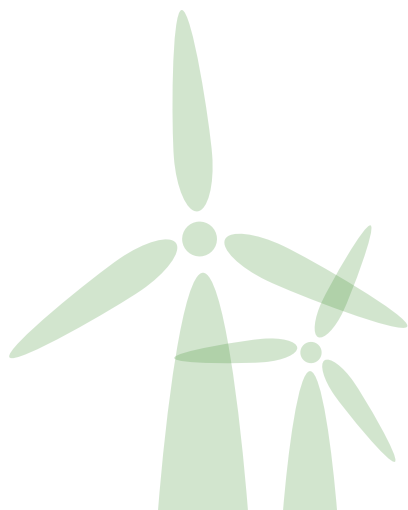

Schematic diagram/single line diagrams (QI100)

You must provide a schematic diagram showing the electrical layout of the installation. The diagram doesn't need to be complicated. It should be clearly labelled and easily understood. At a minimum, it should include the location of the following:

- All generating equipment associated with the installation (such as solar panels and inverters),
- Any other installations sharing the same grid connection,
- Other electrical loads not associated with the installation (such as buildings supplied with electricity from the installation),
- Any standby generation and associated interlocking facilities,
- All import and export connections,
- Location and details of all electrical metering including the meter make, model and serial numbers.



A - Simple Solar PV Installation

Example A shows a grid-connected solar PV installation with no onsite loads or nearby installations. This is typical of a stand-alone solar PV installation.



B - Complex Wind Turbine Installation

Example B shows a more complex installation with two 80kW wind turbines sharing a connection to the grid. In this instance, an existing installation of a different technology (PV) also shares the same grid connection.

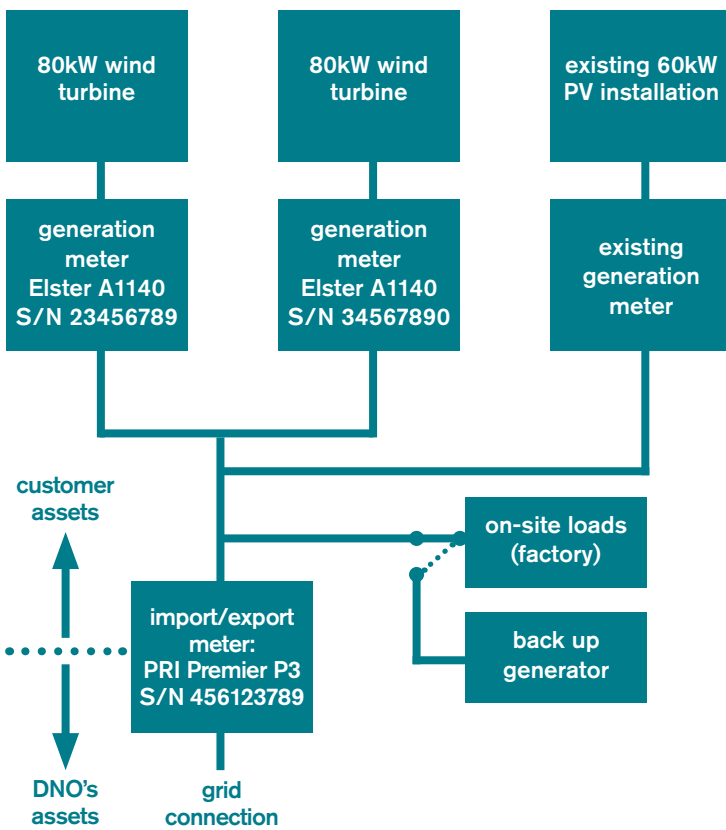

Also shown is an onsite load (a factory). The factory has a standby generator and interlocking is in place, and clearly indicated, to make sure that the standby generator cannot add to the generation or export meter readings.

The application form



Technology-specific questions

This section explains the questions asked in the ROO-FIT application form that are specific to the technology used.

Solar photovoltaic

Standard or stand-alone (QC 125)

There are two categories of solar PV installation in the FIT scheme – Standard and Stand-alone. These categories are used when determining the FIT generation tariff.

The definitions of these terms vary depending on the TIC of an installation. For more information please take a look at the 'Feed-in Tariffs: Guidance for renewable installations'.

Energy efficiency requirement (EER) and multi-installation tariff (MIT) (QC127 and QC235)

If the solar PV installation is a standard installation and has a TIC of 250kW or less, it will be assessed against both the EER and MIT requirements. Take a look at the 'Feed-in Tariffs: Guidance for renewable installations' for a more detailed explanation.

The results of these assessments will determine whether the higher, middle or lower PV generation tariff will be applied. This table explains the effect of the EER and MIT assessments:

EER met?	MIT applies?	Tariff
Yes	No	Higher
Yes	Yes	Middle
No	Yes or No	Lower

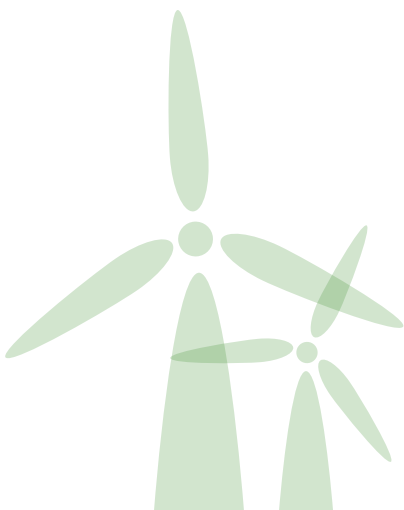

If the EER and MIT requirements apply to your installation, at a minimum you must provide us with:

- a valid Energy Performance Certificate (EPC) of grade D or higher or,
- a self-declaration form completed by the superuser and an accredited EPC assessor to confirm that the installation is not wired to provide electricity to a 'relevant building' as defined in the FIT legislation. A copy of the self-declaration form is available in Appendix 7 of the 'Feed-in Tariffs: Guidance for renewable installations'.
- confirmation that neither of the above can be provided and you are aware the installation will receive the lower tariff.

And

- two declarations signed by the superuser - one EER declaration and one MIT declaration. These declarations are available in Appendix 7 of the 'Feed-in Tariffs: Guidance for renewable installations'.

✓ **TOP TIP:**
The EPC must be valid and issued before the commissioning date.

✓ **TOP TIP:**
If a building is exempt from the requirement to have an EPC under the Energy Performance of Buildings (EPB) Regulations, it does not necessarily mean it is exempt under the FIT scheme if an EPC can still be produced.

Anaerobic Digestion

Fuel Measurement and Sampling (FMS) questionnaire (QJ700)

All AD FIT applications must be accompanied by a completed Fuel Measurement and Sampling (FMS) questionnaire. It should be signed by the superuser and submitted with your application. The questionnaire asks you to explain how you plan to measure and sample the fuels you intend to use. These processes must be agreed with Ofgem before accreditation can be granted. It should be signed by the superuser and submitted with your application. Please see Feed-in Tariffs: Guidance on sustainability criteria and feedstock restrictions for more information.

Technology-specific questions



Hydro

Civil works diagram (QE300 and QE400)

All hydro applications must be accompanied by a description of the man-made structures associated with the installation – the ‘civil works’ - and a civil works map. This map should include all abstraction and impoundment points, pipelines, powerhouse and tailrace. If the civil works are shared with another hydro project, these should be clearly labelled on the map.

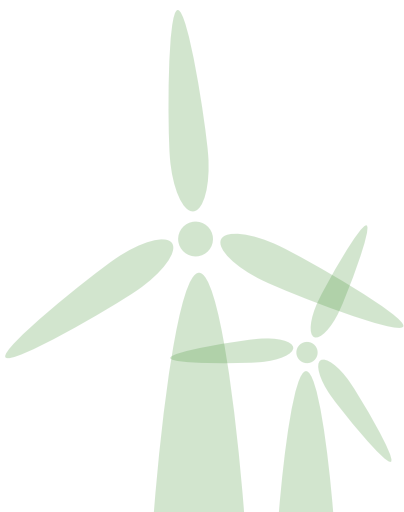

Application checklist

- ✓ Are all questions complete, with no gaps?
- ✓ Are all answers correct and consistent, with no spelling mistakes?
- ✓ Have you entered the right meter details? Do they match the single-line diagram?
- ✓ After clicking 'send', get the account superuser to agree the online declarations by clicking on 'declarations'. Your application will join the deployment caps queue based on the date and time that you click 'send'. However, we will not begin to process your application until you agree all relevant declarations.
- ✓ Gather the commissioned and TIC evidence discussed above:
 - ✓ A copy of the G59 test certificate signed by the witnessing DNO or a letter or email from the DNO stating that it did not wish to witness this test
 - ✓ A signed declaration from your commissioning engineer or installer confirming the commissioning date
 - ✓ A signed statement from the installer or manufacturer of the generating equipment confirming the TIC of the installation



Your responsibilities

Before you apply

Before completing an application, familiarise yourself with the 'Feed-in Tariffs: Guidance for renewable installations' which explains in detail the requirements that must be met.

Agreeing Declarations

We will not review your application until all declarations are agreed. The superuser is the only user who can agree declarations. All declarations are found in the 'Agree Declarations' section of your account on the Renewables and CHP Register.

Once an application has been submitted, the superuser will get an email confirming that we've received it. This is usually sent within one working day. Please contact the ROO-FIT team (see details at the end of this document) if you do not receive this email.

Responding to queries

All applications go through a two- or three-stage review process depending on how complex the application is. If anything is unclear, inconsistent or we require additional evidence, we will raise queries through the Renewables and CHP Register.

If a query is raised, the superuser will receive an 'Action Required' email. All queries must be responded to before an application can be submitted back to us.

 **TOP TIP:**

When queries have been raised, we will take no further action until you respond. It is your responsibility to answer queries and resubmit the application promptly to prevent delays.

 **TOP TIP:**

Responding to queries and resubmitting an application does not affect the eligibility date of the installation.

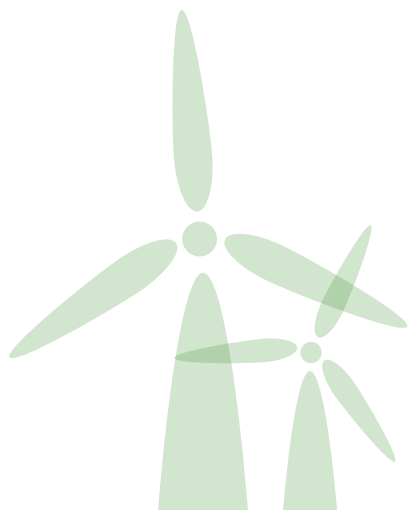

Amending your application

We may ask you to amend answers in your application. Responding to queries does not automatically change the answers on your application form. If you require help responding to queries and resubmitting your application please contact the ROO-FIT team.

If we ask you to amend your application, login to your account then:

- **Click 'Respond To Queries Raised From Ofgem On Your Accreditation Application'**
- **Answer ALL queries that have been raised**
- **Once all queries have been answered and saved, you will have the option to 'Edit your Application' or 'Submit Response'**
- **To edit questions on the application please click 'Edit your Application'**
- **Go to the question you wish to amend and click 'Edit'**
- **Once you have edited all the necessary questions please click 'Next' until you reach the end of the application**
- **You will then see the option to 'Re-submit your application'. Once you click this button, a review screen will appear with all your changes. Please scroll to the bottom of this screen and click 'Submit Response'**
- **If successful, you will get an automated email saying that we've received your query responses**

Applying for REGO accreditation

You can apply for the Renewable Energy Guarantees of Origin (REGO) scheme alongside your ROO-FIT application. For more information on the REGO scheme please see our website.

REGOs are used by licensed electricity suppliers as evidence to support their Fuel Mix Disclosure (FMD) claims annually. Suppliers must hold REGOs by 1 July for REGOs issued on generation during the previous April to March period.

If you submit a joint ROO-FIT/REGO application and your ROO-FIT application is queued for a tariff period that hasn't yet opened, we are unable to accredit your application until after your tariff period opens.

If you are eligible and wish to claim REGOs sooner, you can separate your applications and make a REGO only application. Please advise us if you wish to separate your application to claim REGOs by emailing ROOFIT@ofgem.gov.uk.

If you separate your applications you won't be able to use the same generating station name used for your FIT/REGO application. So we can still link the two applications you can use "Name of your generating station_REGO".

Please note, at this stage we will not amend your joint FIT/REGO application for accreditation. If your applications are successful we will link them back together upon accreditation for FIT.



Contact the ROO-FIT team

The ROO-FIT team can be contacted:

By email: ROOFIT@Ofgem.gov.uk

By telephone: **0207 901 7310**

By fax: **0207 901 7387**

By post: **Ofgem
9 Millbank
London SW1P 3GE**

We can advise you on completing the application form but we cannot provide technical or legal advice. We are also unable to provide guidance on proposed installations where no application has been submitted.

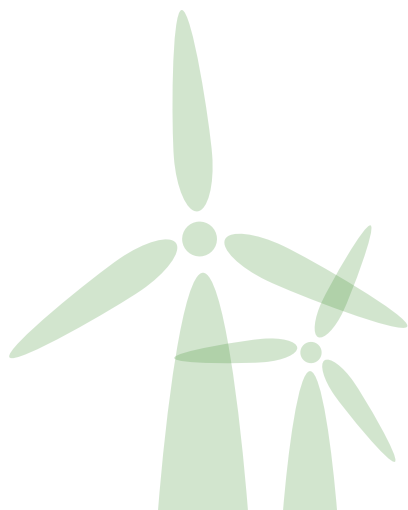

Complaints

Complaints about the administration of the scheme

If you have a complaint about how your application is being handled or about a decision we have made, please email ROOFIT@Ofgem.gov.uk

Complaints about the legislation or policy

The Department for Business, Energy and Industrial Strategy (BEIS) is responsible for setting the FIT policy and legislation. If you have any comments, questions or would like to make a complaint about the FIT policy or legislation, please contact BEIS: enquiries@beis.gov.uk

Complaints about FIT payments or your FIT licensee

Send any complaints about FIT payments or your FIT licensee to your FIT licensee. If after eight weeks a satisfactory solution has not been agreed, the complaint may be referred to the Energy Ombudsman:
www.ombudsman-services.org/energy.html



London

9 Millbank
London SW1P 3GE
Tel: 020 7901 7000

Scotland

Commonwealth House
32 Albion Street,
Glasgow,
G1 1LH
Tel: 0141 331 2678

Wales

1 Caspian Point
Cardiff Bay
CF10 4DQ
Tel: 029 2044 4042

www.ofgem.gov.uk