

Transmission Owner Innovation Roll-Out Mechanism Submission Pro Forma

Application to Innovation Roll-out Mechanism

Notice for adjustment to IRM Value

SP Transmission Ltd

[PUBLIC]

Executive Summary

Large centralised generation plants, whose capacity is known from the outset, often take decades to plan and build allowing the Transmission Owner sufficient time to plan network reinforcement. The volatility of the wind generation industry presents new challenges to reinforcement; providing sufficient, but not excessive, capacity quickly, efficiently and effectively. By avoiding the construction of a new line, the high capacity offered by high temperature low sag conductor technology will prove a valuable tool in enabling the Transmission Owner to address these challenges and facilitate renewable generation. Implementing the use this new technology will cultivate confidence and progress it toward business as usual.

Table of Contents

Section 1: Application Summary	2
Section 2: Application Description	6
Section 3: Application Business Case	21
Section 4: Evaluation Criteria	28
Section 5: Regulatory Issues	36
Section 6: Appendices	40

Transmission Owner Innovation Roll-Out Mechanism Submission Pro Forma

Section 1: Application Summary

Section 1: Application Summary

1.1 Application Title

Deployment of new composite-core High Temperature Low Sag Technology (HTLS) for transmission network reinforcement

1.2 Estimated Total Cost

£44.5m

1.3 Total Funding Request

£27.13m – Excluding funding secured through other mechanisms

The funding request constitutes a “Material Amount”, in accordance with Licence Condition 6E.8.

1.4 Proposed IRM Adjustment

	Relevant year		
Proposed adjustment	2015/16	2016/17	2017/18
IRM Value (£ m)	0.55	23.73	2.85

1.5 Start date

July 2015

1.6 End Date

March 2018 (end regulatory year 2017/18)

Transmission Owner Innovation Roll-Out Mechanism Submission Pro Forma

Section 1: Application Summary continued

1.7 Application Summary

This application seeks funding under the Innovation Roll-out Mechanism (IRM) to deploy new all-Aluminium HTLS technology to reconductor sections of 275kV overhead line (OHL) in the South-West region of Scotland where generation has greatly exceeded what was anticipated in the RIIO-T1 Price Control Business Plan.

The SP Transmission (SPT) 2010/11 Business Plan submission for the RIIO-T1 Price Control forecast 2.5GW of new generation connecting to the network by 2021, from which the load-related investment allowances and targets were set. Following a remarkable increase in wind farm developments 4.9GW of new generation is already connected or in planning, and the Baseline Shared Use Infrastructure (BSHE) target of 1,073MVA (to which this project relates) will be achieved 2016.

The region surrounding Mark Hill and Coylton in the South West of Scotland has witnessed a particularly buoyant transmission and distribution wind generation market. Under the Transmission Owner (TO) licence, SPT are obligated to facilitate these new connections to the system efficiently and reliably.

Furthermore, through RIIO, the TOs are incentivised to innovate and integrate new technologies and practices into Business as Usual (BaU) as to optimise capital and operational expenditure. SPT's decision to accelerate the use of Aluminium Conductor Composite Reinforced (ACCR) High Temperature Low Sag conductors in place of traditional All Aluminium Alloy Conductor (AAAC) conductors demonstrates SPT's commitment to embrace innovation and technological advancements.

In 2014, National Grid concluded a successful IFI and NIA funded assessment of the installation and performance of this particular HTLS conductor, manufactured by 3M, against existing HTLS technology. This study provided encouragement for SPT to consider this technology, which offers greater capacity without increasing weight, for the first time as part of a reconductoring scheme. The lightweight conductor can avoid tower strengthening and foundation works and, in some cases, the extra capacity will avoid the need to undertake major tower reinforcement/rebuilding work.

The first HTLS installation will mark a technological step-change to the next generation of conductor technology but in order to bring this to BaU a wealth of internal learning and process is required. However, once higher-capacity HTLS options are integrated into BaU, the long-term overall infrastructure costs will decrease, achieving longer-term value for money for electricity consumers through:

- reducing long-term capital expenditure where conventional practices warrant new towers or tower reinforcement works,
- facilitating quicker connections, especially for renewable generation
- the avoidance of constraint costs, through the additional capacity headroom

SPT understands the intention of the IRM is to overcome commercial barriers that may exist to the TO within the present Price Control (i.e. the lack of financial incentives and level of risk) and encourage Transmission Network Owners to implement new proven technologies that will deliver long-term value for customers but do not, currently, form part of Ordinary Business Arrangements. This document seeks to demonstrate the alignment with the overall strategy of the IRM.

Transmission Owner Innovation Roll-Out Mechanism Submission Pro Forma

Section 1: Application Summary continued

The HTLS technology will be deployed on two adjoining routes that require uprating by 2016 to accommodate additional generation into Mark Hill and Coylton 275/132kV substations whilst ensuring the Security and Quality Supply Standard (SQSS) is upheld, and without detriment to the operation of the Moyle interconnector.

- Coylton to Mark Hill, 49.5km single-circuit (known as the YY Route), and
- Kilmarnock South to Coylton, 15.5km double-circuit (known as the XY Route)

In order to accelerate the connection of wind generation, reduce investment cost (which may otherwise deter generations), and minimise the outage times for the generators and Moyle Interconnector, the reconductoring the delivery of these works has been fast-tracked to take place over two consecutive outage seasons in 2015 and 2016. The reconductoring of XY Circuit 2 and YY Circuit is scheduled to run simultaneously, for final commissioning in 2016.

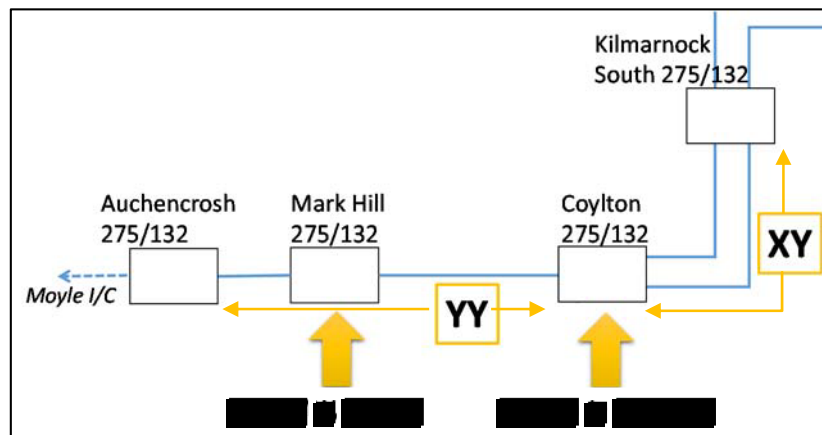

Figure 1. YY and XY Routes for reinforcement due to increased generation during RIIO-T1

The total combined cost of uprating both circuits using the latest HTLS conductor technology is £44.5m, whereas the BaU would cost in excess of £100m. This covers the full scope of works including the engineering design, conductor purchase, contracted project delivery.

A lesser form of the XY Route uprating fell under an extensive reinforcement initiative in the RIIO-T1 business plan. The IRM funding sought is £27.13m and excludes the pre-assigned allowance of £17.4m in relation to OHL works on the XY Route.

Installing a new conductor system which has not been deployed elsewhere in the UK entails risk and uncertainty. The IRM mechanism encourages the uptake of such advancements that will ultimately benefit electricity consumers. Conventional uprating options exist at higher cost but at less risk, however, given the timing of the need to reinforce and the significant pressure to minimise the outage time on the YY Route, SPT have decided to deploy the HTLS conductor on both circuits to benefit from greater economies of scale in purchasing the expensive conductor, gain experience from the 2015 installation to optimise installations in 2016 and beyond, and allow accurate unit-cost information to be determined.

Transmission Owner Innovation Roll-Out Mechanism Submission Pro Forma

Section 1: Application Summary continued

The benefits of reconductoring the proposed circuits in the proposed way are:

- Facilitating and accelerating additional renewable generation during RIIO-T1 (into Mark Hill and Coylton), above RIIO-T1 baseline targets
 - Delivering quicker circuit uprating (avoiding planning delays) to meet a generation market that is double the baseline plan forecast
 - Circuit capacity increase of YY Route from 504MVA to 924MVA and XY Route from 640MVA to 1600MVA without major tower works
- Environmental benefits by avoiding tower replacement and strengthening works
 - Reduction of over 4,000 tonnes of steelwork by avoiding construction of 44 single circuit towers and 150 double circuit towers
 - Reduction of over 8,500 tonnes of concrete by avoiding construction of 44 single circuit towers and 150 double circuit towers
- Delivering the necessary capacity quicker and at improved pound-per-Megavolt-ampere (£/MVA)
 - Uprating the YY Route for £43m less, improving value for money by £75k/MVA, and at least 8 years earlier than the BaU alternative
 - Uprating the XY Route for £19m less, improving value for money by £6k/MVA, and at least 8 years earlier than the BaU alternative

Coupled with the over-arching 'South West Scotland' project, the proposed work will increase the total export capability from Coylton to the wider 400kV network and

- Contribute 1.7GW by 2021 (and 2.1GW by 2023) of additional renewable generation to the GB system, representing 40% of SPT's onshore wind

Table 1. Planned programme of reconductoring works

Outage Season	YY Route	XY Route
2015		Circuit 1 stringing
2016	Circuit 1 stringing	Circuit 2 stringing, new GIS installed
Estimated Cost	████████	████████

Transmission Owner Innovation Roll-Out Mechanism Submission Pro Forma

Section 2: Application Description

Section 2: Application Description

The background behind this application, the new HTLS technology and the details of the proposed reconductoring of the routes are detailed in this section.

2.1 Overview

In 2014, National Grid concluded a successful IFI and NIA funded offline assessment of the installation and performance of a particular all aluminium HTLS conductor, manufactured by 3M, compared to existing HTLS technology. The technology used by 3M offers quicker and easier installation of a HTLS conductor system, providing double the capacity of similar-sized conventional AAAC conductors with negligible increase in weight. The Annual IFI Report 2012/13 in Appendix A summary provides an outline of the offline study.

This new HTLS technology can be operated at up to 210°C continuously without changing its mechanical or electrical properties, offering greater ampacity without increasing weight thereby avoiding tower strengthening and foundation works and, in some cases, the extra capacity will avoid the need to replace single-circuit towers to accommodate a double-circuit.

National Grid's project provides confidence for SPT to roll-out this now proven technology for the first time in the UK as part of a reconductoring scheme under the IRM to ensure the changing nature of the decentralised generation is delivered as efficiently and effectively as possible.

Since the turn of the decade, there has been a growing need to reinforce parts of the transmission and distribution networks in Scotland. Due to the terrain and places of outstanding beauty, erecting new towers is an increasingly complicated and expensive task, thus the need to increase the capacity of existing circuits is ever more pressing. Thus, the business case supporting HTLS has become ever more attractive.

The key driver for this application is the facility of the HTLS technology to avoid the need to rebuild a circuit, which was subject to public enquiry when it was first installed, and synergise with wider reinforcement works in the South West of Scotland. By combining the XY and YY works, SPT intend to ensure the outage time of the YY Route is kept to an absolute minimum. An overview of the routes where HTLS conductors are to be deployed for the first time by SPT is presented below in Table 2.

Table 2. Overview of XY and YY circuit information

Route	Coylton – Mark Hill (YY Route)	Kilmarnock South – Coylton (XY Route)
Existing Conductor	1x500mm ² Rubus - All Aluminium Alloy Conductor (AAAC)	2x400mm ² Zebra - Aluminium Conductor Steel Reinforced (ACSR)
Circuit length	49.5km	15.5km
Pre-fault rating	504MVA	640MVA

Transmission Owner Innovation Roll-Out Mechanism Submission Pro Forma

Section 2: Application Description continued

2.2 Needs' case for reinforcement

The need to reinforce is driven by increased renewable generation in the South West of Scotland with only one exit route to the wider system through the Kilmarnock South 275/132kV substation, as depicted in Figure 2 below.

At the time of submitting the Price Control Business Plan in 2010/11 SPT's "Best View" scenario forecast 2.5GW of new onshore wind generation across the whole network, with 1.3GW forecast to affect the Mark Hill and Coylton collector substations. Since 2010/11 SPT have witnessed an unprecedented uptake of onshore wind generation and have already contracted 4.9GW of generation by 2021 - the Mark Hill and Coylton region alone accounting for 1.7GW by 2021 (and 2.1GW by 2023).

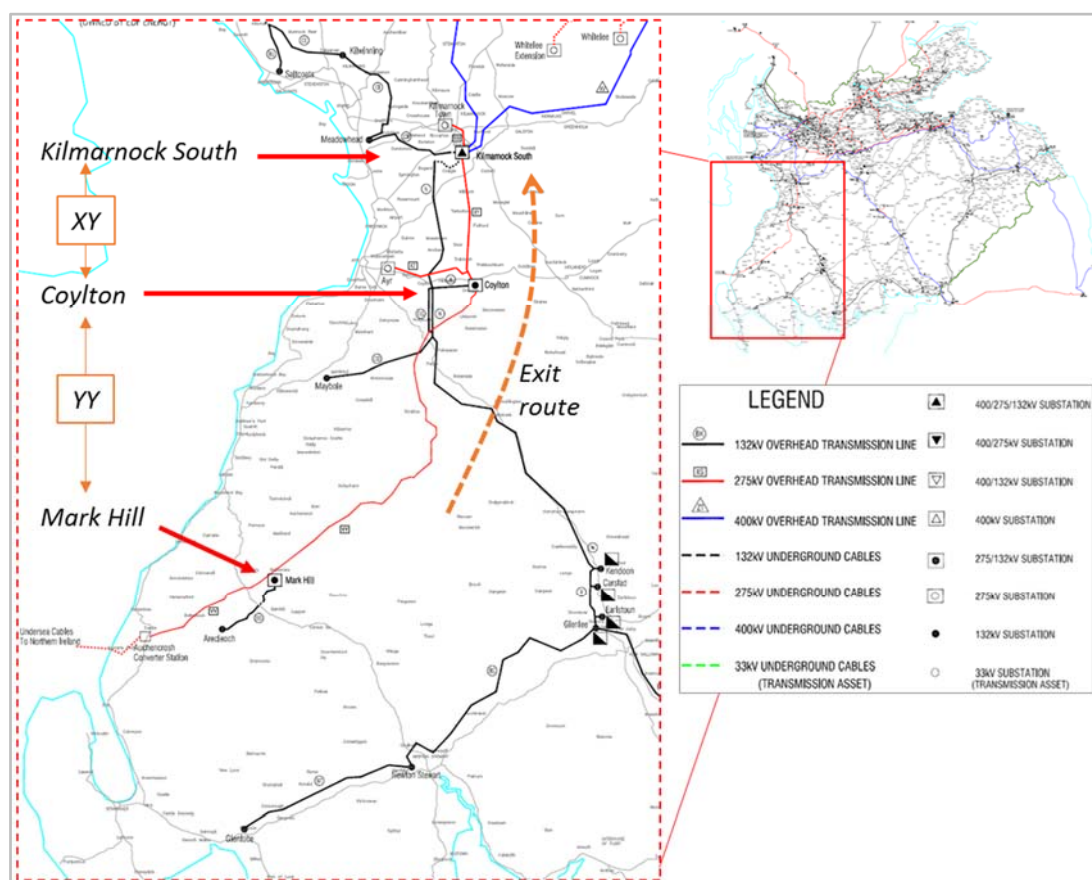

Figure 2. Transmission Network map of South-West Scotland, indicating XY and YY routes and the only exit route for generation in the area via Kilmarnock South

The need to uprate the YY route was not identified until after the RIIO-T1 business plan submission in 2010/11. A lesser form of the XY Route works was included under a wider set of reinforcement schemes in the 2010/11 submission, known as the South West Scotland (SWS) project. Based on the best available information at the time, the SWS plan for the XY Route is no longer sufficient to provide the necessary capacity and the next BaU alternative would require tower works. Considering the likely continual growth in the region, the HTLS solution offers high capacity in a quicker timescale and avoids the need for tower steelwork and foundation strengthening.

Transmission Owner Innovation Roll-Out Mechanism Submission Pro Forma

Section 2: Application Description continued

2.3 Generation increase from RIIO-T1 Baseline Position

A remarkable degree of increased generation is the key driver for this project. The Business Plan submitted in 2010/11 forecast approximately 1GW of onshore wind generation to connect in the South West of Scotland during RIIO-T1. This figure is currently expected double, as presented below, in accordance with the SO Ranking Order.

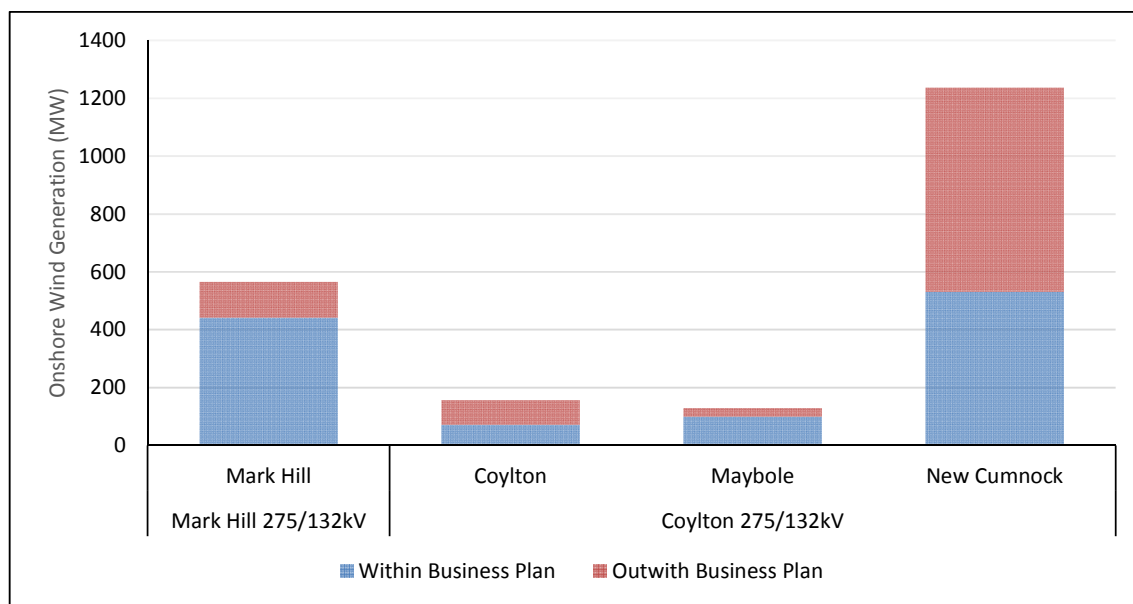

Figure 3. Contracted generation at Coylton and Mark Hill within and outwith the Business Plan, contracted to connect by 2021

The predominant recent changes that have triggered the need for the reinforcement of the XY and YY routes are:

- Glen App and Loch Ree wind farms accepting connection offers in 2013,
- Kilgallioch wind farm applied to increase to full capacity from a non-firm to a firm basis from 2016,
- The large level of potential wind generation connecting to New Cumnock substation – to be constructed as part of the SWS Project.

The figure above is based on the current 2015 Ranking Order which is set to be finalised in March 2016. This provides a forecast of the potential generation based on the connected and contracted projects up to 2027. However, due to the nature of the consenting process, the timing and eventual outturn of the Ranking Order is subject to change, and therefore must be considered carefully in planning major reinforcement.

SPT must take into account the fluidity of the generation market to efficiently manage and plan network reinforcement; the proposed reconductoring of the XY route using a high capacity conductor provides SPT with the ability to manage this uncertainty.

Transmission Owner Innovation Roll-Out Mechanism Submission Pro Forma

Section 2: Application Description continued

2.4 Business As Usual (BaU) reinforcement

In order to uprate any circuit, aside from increasing operating voltage, two fundamental options exist:

1. Increase the capacity of the conductors, typically by increasing physical conductor size or operating temperature (usually from 75°C to 90°C),
2. Increase the number of conductors, typically by introducing parallel circuits (e.g. double-circuit) or increasing number of bundled conductors per phase.

Both options conventionally increase the overall weight of the circuits to be suspended by towers and consequently increase the strength requirements of the tower steelwork and foundations which, if exceed the existing capability, will incur additional cost, complexity and increased environmental impact.

In uprating an existing transmission line, it is imperative to consider the existing towers. Various tower designs are deployed throughout the network depending on the transfer requirements, terrain, and public approval, and circuits commonly compromise of multiple types of tower. Each tower has different characteristics in terms of strength, height and style, defining the type and number of conductors it can accommodate.

For every span of each circuit, the conductor sag profile is modelled to ensure the statutory ground clearances are upheld across the entire circuit at a given operating temperature. As conventional AAAC conductors sag increases with temperature, an assessment of the sag profiles must be conducted before the operating temperature can be increased.

Technical design studies undertaken to assess the uprating options for the both XY and YY routes are summarised below (further detail in Section 2.6 and 2.7).

2.4.1 Summary of Mark Hill to Coylton (YY) uprating

The YY Route single-circuit connects Coylton, Auchencrosh and Mark Hill 275/132kV substations. Two options provide the necessary capacity increase:

- a) Retain a single-circuit arrangement and uprate the OHL conductors, by either operating at a higher temperature or restringing with higher capacity conductors,
- b) Install a second circuit by either replacing the existing single circuit towers with double circuit towers, or erecting a new set of towers in parallel.

Given the cost implications of replacing the 150 single-circuit towers between Mark Hill and Coylton, a tower replacement scheme could not be justified without previously exhausting all alternative options.

Operating the existing conductors at higher temperatures (75°C to 90°C) would not provide sufficient capacity and so discussions began regarding the potential use of new HTLS technology, which was (and still is) in its infancy in the UK.

Transmission Owner Innovation Roll-Out Mechanism Submission Pro Forma

Section 2: Application Description continued

The Gap-Type Aluminium Conductor Steel Reinforced (GZTACSR/GTACSR) conductor has been designed for the UK market as a potential successor to the ACCC. Capable of operating at 170°C, the GTACSR “Matthew” conductor would achieve an increase of 170MW thermal capacity on the YY Route. However the steel element of the conductor adds weight, and the existing tension towers would need strengthening, with vertical loading increasing up to 73%. The initial design study estimated the total cost at approximately £18.5m with a substantial degree of uncertainty surrounding conductor cost. Whilst the costs are comparable to the ACCR HTLS the complicated installation and uncertainty of life span mean the ACCR HTLS is preferred.

2.4.2 Summary of Coylton to Kilmarnock South (XY) uprating

The original proposal to uprate the XY Route, as part of the SWS Project, replaced the existing OHL conductor (twin Zebra, 2x400mm² ACSR) with a larger conductor (twin Rubus, 2x500mm² AAAC), achieving an OHL increase in the pre-fault summer rating from 640MVA to 1,160MVA per circuit. An underground section on one of the circuit limits the capacity of the circuit and must also be replaced as part of the uprating.

Since setting out the Price Control Business Plan, the increased generation portfolio in the region has doubled the capacity requirements, see Figure 4, and consequently drove the need to consider the use of a HTLS solution.

As SPT investigated HTLS as a possible solution to reinforcing the YY route, it was identified it would be beneficial to co-ordinate the implementation of the two neighbouring reinforcement projects and synchronise the commissioning year thereby achieving greater economies of scale in purchasing the HTLS line.

The initial allowance of £17.4m for the XY route, as part of the SWS Project, allocated £12.7m to the OHL element using AAAC (Rubus), delivering 1,020MVA per circuit. The cost of uprating the double circuit with ACCR HTLS [REDACTED] delivers an improved capacity per circuit of 1,600MVA.

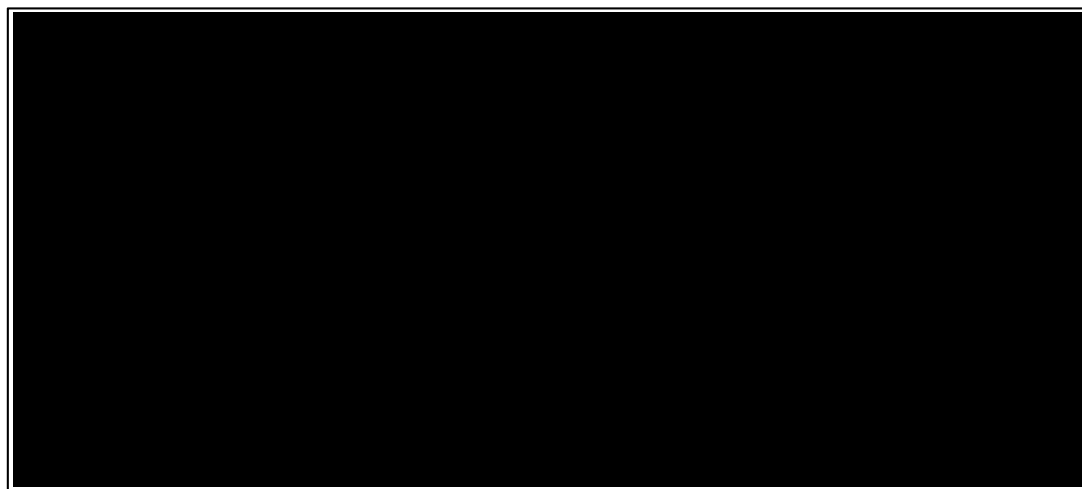

Figure 4. Future increase in generation into Mark Hill and Coylton collection substations

Transmission Owner Innovation Roll-Out Mechanism Submission Pro Forma

Section 2: Application Description continued

2.5 The High Voltage Low Sag conductor

The reluctance of the electricity industry to install high temperature conductors has largely been due to the immaturity and the high cost of HTLS technology. For newly constructed overhead lines projects the material value alone would be increased by 2-3 times that of an existing conductor system.

HTLS conductors benefit from operating at much higher temperatures resulting in increased load transfer capacities and allowing conductors with a smaller cross sectional area to be installed. At present, the cost HTLS is higher than conventional AAAC conductors but the smaller cross sectional area can offer reduced weight and low sag solutions can avoid the need for tower and foundation reinforcement.

2.5.1 Gap-type HTLS conductor system – ACSR, code Matthew

National Grid and Scottish Hydro Electric (SHE) Transmission have jointly investigated the use of Gap-Type Super Thermal-Resistant Aluminium Alloy Conductor Steel Reinforced (GZTACSR) HTLS conductor, code Matthew. The gap-type HTLS is designed to operate at 170°C and offers low sag operation by allowing the outer conductor to expand independently from the core (which is clamped to towers), as shown below.

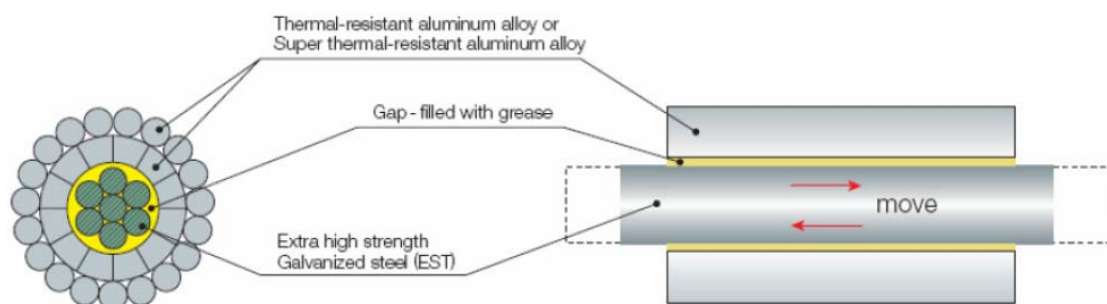

Figure 5. Cross-section of gap-type Aluminium Conductor Steel Reinforced (GTACSR)

The studies undertaken by National Grid and SHE Transmission have reported concerns around the complicated installation process and operational noise. The excessive noise issues have resulted in National Grid undertaking a separate IFI project to understand the causes of the noise and what mitigation options exist. An extract of the latest published Annual IFI report is included in Appendix G.

As the installation of this type of conductor is notoriously labour intensive it was estimated that the installation of the Matthew conductor on the YY Route would require a seven month outage period which, given the geography of this line and the circuit configuration, would cause an outage to any connection on the circuit. In proposing this option, SPT were under pressure to minimise the outage by the SO.

SPT commissioned a feasibility tower modelling study that found the installation of the Gap HTLS conductor on the YY Route would result in a number of steel structural bars failing (due to the increased weight of the steel). This model uses design codes to identify the conditions where the tower structures are affected by the new loads

Transmission Owner Innovation Roll-Out

Mechanism Submission Pro Forma

Section 2: Application Description continued

imposed by the conductor system. All steel members or foundations that fail during this study would require to be upgraded to withstand the additional forces.

The gap-type HTLS was anticipated to be used for future reinforcement, however SPT became aware of an alternative HTLS conductor system that offered similar current carrying capability at a reduced weight and did not add further complication to the installation process and could therefore be installed more quickly.

2.5.2 Composite core HTLS conductor system – ACCR, code Drake and Curlew

All HTLS conductors systems require the use of innovative alternative designs or components to provide the additional tensile strength required for the conductor assembly to function at higher temperatures. The innovative characteristic of the ACCR conductor system, manufactured by 3M, is an aluminium matrix 'composite' core that provides similar strength to steel but is considerably lighter and its material characteristics do not alter significantly as temperature increases.



Figure 6. Cross-section of Aluminium Conductor Composite Core Reinforced (ACCR) by 3m

The ACCR type of conductor is designed to deliver approximately double the standard transfer capacity on existing structures without requiring major strengthening of the tower steelwork or foundations. This is achieved by a composite core stranded from wires of high purity aluminium reinforced with alumina fibres offering high tensile strength without additional weight. The outer conductor strands are manufactured from hardened (annealed) aluminium zirconium alloy to allow operation at higher temperature (3M have certified a Maximum Operation Temperature of 240°C).

Table 3. Comparison of basic physical and electrical conductor characteristics (for twin bundle)

Conductor Code Name	Type	Nominal Aluminium Area (mm ²)	Weight (kg/km)	Summer Pre-fault Continuous Rating (Amps)
Zebra	ACSR	400	3242	1340
Rubus	ACCC	500	3232	2120
Matthew	GZTACSR	620	2768	3590
Drake	ACCR	418	3374	3382
Curlew	ACCR	525	3242	3878

Transmission Owner Innovation Roll-Out Mechanism Submission Pro Forma

Section 2: Application Description continued

The installation of the ACCR Conductor system is a considerably less complicated and labour intensive conductor system when compared to ACSR HTLS (Matthew). Installed in much the same way as conventional AAAC conductors, a major disadvantage lies with the cost which is in the order of 2-5 times greater than conventional AAAC conductors of a similar size. However, the ACCR solution can still be commercially viable by offering better value in terms of pound-per-megavolt ampere (£/MVA).

There is very little performance data available on the ACCR conductor other than what has been provided by 3M. However, there is no evidence of failure in the past 10 years.

2.5.3 Other HTLS technology

Many HTLS conductors have been manufactured to fit the purpose of the market where they are manufactured and as a consequence may not be suitable as direct replacement for Zebra ACSR. The details can be found at Appendix C, Section 6.3.

For instance, Aluminium Conductor Steel Supported (ACSS) was developed for the American market and although it has a Zinc coated steel core this is not greased and it may therefore be unsuitable for use in the UK.

Similarly, GZACSR was developed predominantly for the Far East and American markets and although the Matthew GZACSR conductor was developed for the UK as a replacement for Zebra ACSR it requires the towers and foundations to be reinforced. In addition, operational experience has indicated that the Gap type conductor experiences noise issues. There is also a question over the lifespan of this conductor.

ACCC conductor has a core consisting of carbon fibres wrapped with a "shell" of continuous glass fibres, a hybrid polymer matrix. This conductor is new to the market and experience is limited. There have been several failures recorded in Poland although the manufacturer disputes that the failure is due to the conductor, rather suggesting that it was due to installation failures. At present there is no way of corroborating this and this example has been included for information only.

2.5.4 HTLS recommendation

An SPT commissioned report evaluated the HTLS options available to the business which recommended the following:

- When the replacement of existing twin 400mm² Zebra ACSR is being considered and there is a requirement for a slight increase in capacity then, given average costs, replacement with twin 425mm² Totara AAAC would be recommended,
- Where system requirements are projected to exceed the capabilities of twin 425mm² Totara AAAC, then, given average costs, it is recommended that an ACCR conductor is considered to be a viable alternative to installing twin 500mm² Rubus AAAC.

An extract from the above report is presented in Appendix C.

Transmission Owner Innovation Roll-Out Mechanism Submission Pro Forma

Section 2: Application Description continued

2.5.5 ACCR training

In order to introduce and integrate the new HTLS technology into the SPT business-as-usual operational practices, a substantial degree of learning is necessary; system validation and testing, development of a Design Specification and an Installation and Maintenance Operations Manual, and staff training are all prerequisites in order to deploy the first HTLS conductor installation on SPT's network.

A key benefit of the ACCR System is its similarity to existing conductor systems, especially in the manufacturing and installation processes. However, there is a need to ensure that the correct procedures recommended by the manufacturer and specifically the method of jointing the Aluminium Matrix core are fully understood by the operative installing the conductor.

Appendix E details four key areas of the proposed training course that must be completed in advance of the installation of the new ACCR Conductor system.

1. General Training
2. Full System Installation Training
3. Key Component Competence Training
4. Project and conductor system awareness

2.5.6 ACCR technical tests

As the part of 3M that has developed these conductors is based in North America, ACCR Technical tests have generally been carried out to American Society for Testing and Materials, American National Standards Institute and The Institute of Electrical and Electronics Engineers standards. 3M have confirmed that 'Curlew' ACCR_1036-T13 has been tested to International Electro-technical Commission (IEC) standards. The defining core of both 'Curlew' and Drake' systems are identical, therefore, SPT are satisfied that the standard of the core is sufficient to allow the initial installation of the Drake conductor system. A review to compare reference terms used for the North American and European tests is being carried out.

2.6 Planning for efficient delivery of HTLS deployment

The initial outage plans introduced a commercially unacceptable disconnection for seven months and SPT were asked by the SO and connected users to review the construction processes in order to obtain efficiencies during the delivery of the project. Appendix F highlights a number of efficiencies from the perspective of the Overhead Line Network Engineering Design Team.

The review of the revised scope for the replacement of the conductor system on the YY Route identified a number of programme efficiencies with improved contract strategies and initiatives when comparing the original proposal. For example, as mentioned above, a key advantage of the ACCR HTLS versus the gap-type ACSR HTLS is the simplicity of installation. The gap-type HTLS requires core clamping at multiple intervals along a circuit; avoiding this is estimated to reduce outage time by 3 week. In total, deploying the ACCR HTLS solution in place of the ACSR HTLS reduced the required outage window from 7 months to 5 months.

Transmission Owner Innovation Roll-Out Mechanism Submission Pro Forma

Section 2: Application Description continued

2.7 YY Route details

The YY Route single-circuit connects Coylton, Auchencrosh and Mark Hill 275/132kV substations. The section between Mark Hill and Coylton must be reinforced to accommodate new contracted generation into the Mark Hill collector substation.

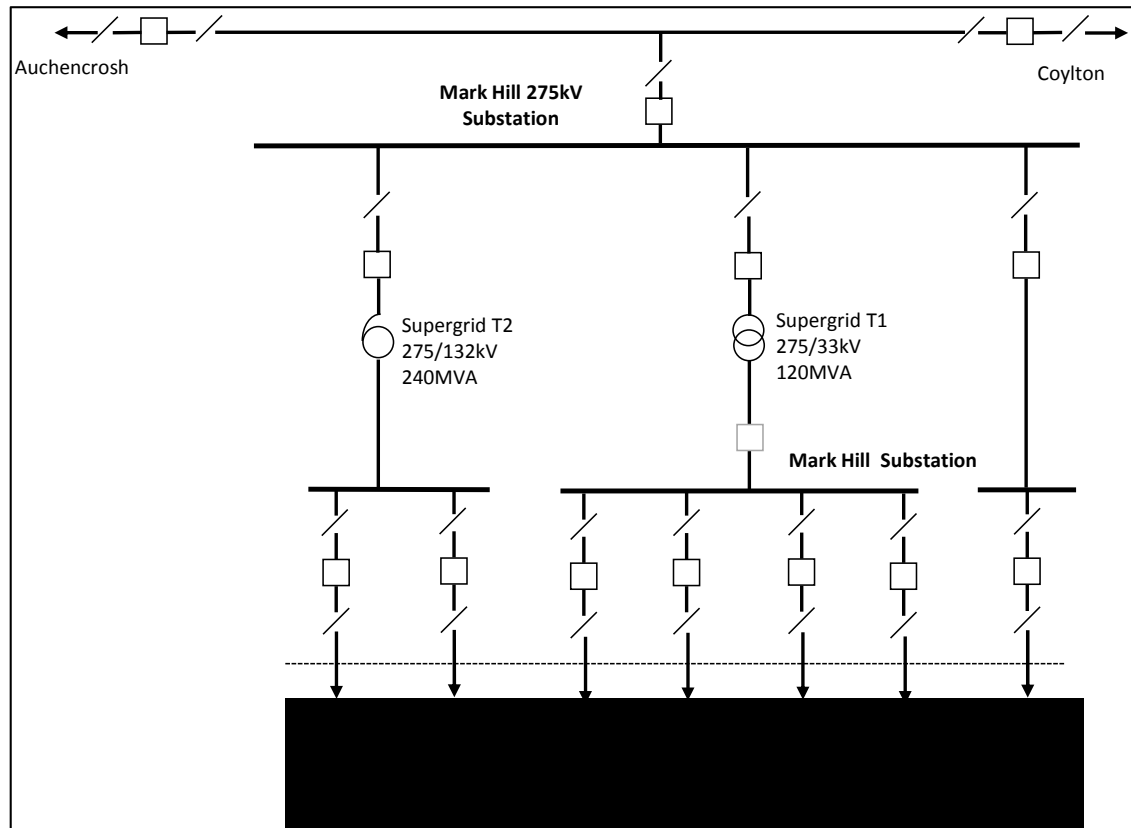

Figure 7. YY Route Schematic and connected and contracted generation connections

YY Route was commissioned in 2003 as part of the project to connect the Moyle interconnector from Northern Ireland to Scotland. The route has 203, 275kV constructed, single circuit towers in horizontal circuit configuration, with 150 towers between Mark Hill and Coylton 275/132kV substations. The conductor system is presently a 500mm² All Aluminium Alloy Conductor (AAAC), code Rubus, with two 160mm² Aluminium Alloy Conductor Steel Reinforced (ACSR) Optical Ground Wire (OPGW) earthwires on the tower peaks.

The route was constructed in a very rural environment and construction crews struggled to establish sites for pulling positions in the remote locations. Up to six helicopters were used continually throughout the construction to ferry resources, materials, equipment and pulling bonds throughout the route. It is not envisaged that as many helicopters would be required for this work. However there are still sections of the line where all inspections and visits are carried out by helicopters.

Transmission Owner Innovation Roll-Out Mechanism Submission Pro Forma

Section 2: Application Description continued

A public inquiry was required to achieve consent to build the line in the mid-1990's. At the time, this line was solely constructed as being a connection the Northern Ireland interconnector. The circuit was driven by the interconnector customer and a single circuit deemed sufficient at the time [REDACTED]

[REDACTED] For this reason, and because of the many objections that were received when SPT were trying to secure planning consent for the line, a low-profile single circuit tower was used. This tower is not capable of supporting another circuit.

The figure below provides insight into the nature of the rural terrain between Coylton and Mark Hill, as the circuit transverses the Galloway Forest Park.

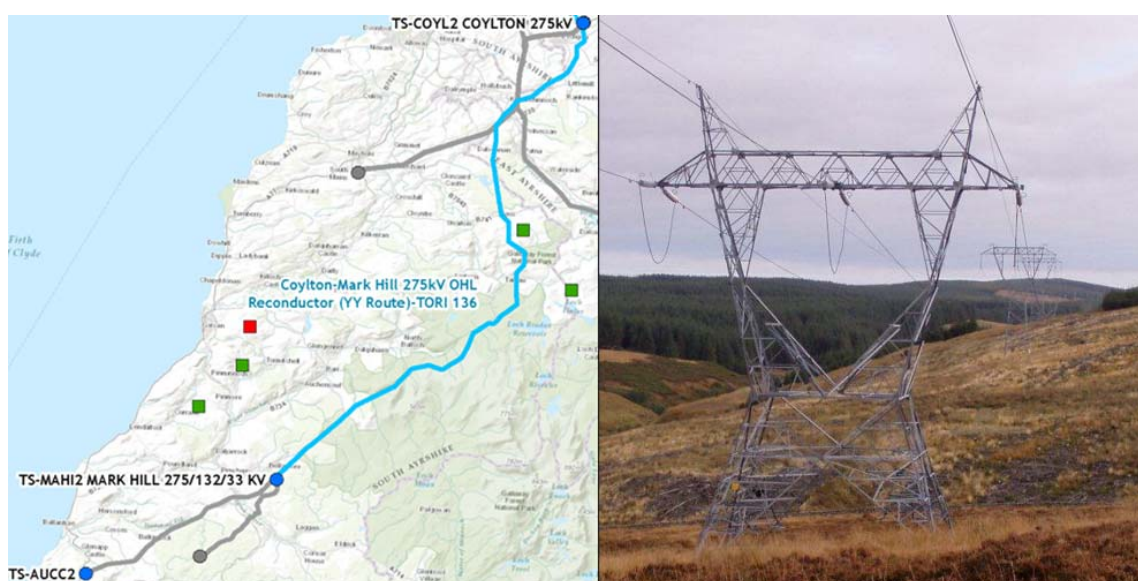

Figure 8. GIS map of the route and photograph of a LR tower, aka. "Cats head"

The uprating works will replace the existing single-circuit AAC Rubus conductors between Coylton to Mark Hill (150 towers) with ACCR Curlew over a 5 month outage period in the 2016 outage season. The main reconductoring work (thus the outage) will take place between May and October 2016, with preparatory site access works commencing in late 2015. A programme of works is provided in Appendix D. Table 4 details the resultant increase in circuit capacity.

Table 4. Increased YY circuit ratings using ACCR HTLS (Curlew)

Type	Pre-Fault Continuous Summer Rating	
	Amps	MVA
Rubus 1x500mm ² AAC (Existing) @75°C	1060	504
Curlew 1x525mm ² ACCR @210°C	1930	924

Transmission Owner Innovation Roll-Out Mechanism Submission Pro Forma

Section 2: Application Description continued

The unusual arrangement of the existing circuit restricts the ability to uprate. The BaU alternative to achieve the necessary uprating of the route would be to build an additional single circuit to between Mark Hill and Coylton substation, erecting 150 new towers alongside the existing circuit. Given the difficulty in gaining public approval for the installation in 2003 where the low-profile towers had to be used, SPT anticipate a second circuit would experience even greater public opposition and achieving planning consent may take longer than before.

The high cost and certain planning delays led SPT to explore the use of HTLS technology for reconductoring. For the purposes of this application, the BaU alternative has been costed to support the decision to reject the new circuit option. The table below illustrates the cost of installation a new circuit in parallel with the existing one, which would also require a new transformer bay at each end.

Table 5. Breakdown of estimated costs of building a new single-circuit parallel to the YY Route

LR Design SC OHL	Cost (£k)
275kV CB and substation bay works (x2)	[REDACTED]
New OHL Contract (Design Build)	
Land Purchase (Towers)	
Environmental Planning Process	
Access Tracks (Civil Contract)	
Estimated Total Cost	

The Moyle interconnector is an HVDC link between the transmission network in Northern Ireland (NI) and the transmission network in Great Britain (GB) linking Ballycronan More in NI to Auchencrosh in Scotland. It has a capacity of 500MW however the full capability has not been available for use due to constraints at either end.

Several wind farms are due to connect to the Auchencrosh - Coylton circuit in South West Scotland, which has reduced the future capacity available to Moyle in the local network in South West Scotland. [REDACTED]

The chosen option will provide sufficient capacity to meet the needs of the contracted generation and interconnector at a saving of £43m against the BaU, with an earlier commissioning date expected to be in the order of 8 years.

Transmission Owner Innovation Roll-Out Mechanism Submission Pro Forma

Section 2: Application Description continued

2.8 XY Route details

The double-circuit XY route, between Coylton and Kilmarnock South 275/132kV substations, is the only exit route to the 400kV system for generation in the South West of Scotland. The exceptional increase of wind generation contracted in the region surpasses RIIO-T1 forecasts and introduces the requirement for greater capacity than originally set out in the RIIO-T1 Business Plan.

The multifaceted SWS project will build substantial 132kV infrastructure and install a new transmission substation (New Cumnock 275/132kV) to accommodate the extensive new transmission and embedded generation in the region. Coylton 275/132kV will be the primary collector substation to export this generation and the XY route must therefore be uprated accordingly.

The SWS plans to uprate the XY Route using twin 500mm² Rubus for £17.4m were based on the best estimates taking the information available at the time, however, in light of the level of transmission and embedded generation, a greater capacity circuit is now required. Had the HTLS solution not been explored, the preferred alternative BaU approach would have been to install a new set of single circuit towers and install a second circuit, at cost in the region of £64m. An overview of the SWS project is included in Appendix B.

The present capacity provided by the XY route is insufficient for the connection of future generation collected by both Coylton 275/132kV and Mark Hill 275/132kV substations, [REDACTED]

[REDACTED] almost double SPT's Best View for this Price Control. Owing to the contracted and consented generation, the uprating of both XY and YY routes has been accelerated to be commissioned in late 2016 rather than 2019 as originally planned to ensure compliance with National Electricity Transmission System Security and Quality Standard (NETS SSQS).

An underground cable at the tee-point at Chipperlaigen restricts Circuit 1 to 640MVA (pre-fault summer rating) without which the rating of the Zebra conductors would accommodate 760MVA. In order to provide the necessary additional exit capacity both the underground cable and OHL sections require uprating. A circuit overview is shown in Figure 8.

The proposed solution will require planning permission for a new site in the vicinity of the Chipperlaigen cable between Towers XY42 and XY43 to establish a GIS busbar connection in place of the existing cable. The existing L2U/L8 tower infrastructure will be utilised to re-conduct the overhead line and no re-routing or diversions are required to carry out this work. Two aspects of the XY Route will be uprated:

- The replacement of the Chipperlaigen cable with a novel GIS busbar system,
- The uprating of the XY overhead line route between Kilmarnock South and Coylton by replacing the existing twin Zebra, 2x400mm² ACSR, conductor with twin Drake, 2x418mm² ACCR, conductor.

The cost of uprating the double circuit with ACCR HTLS Drake is [REDACTED] and provides 1,600MVA per circuit which represents a saving of £6k/MVA compared to the BaU alternative.

Transmission Owner Innovation Roll-Out Mechanism Submission Pro Forma

Section 2: Application Description continued

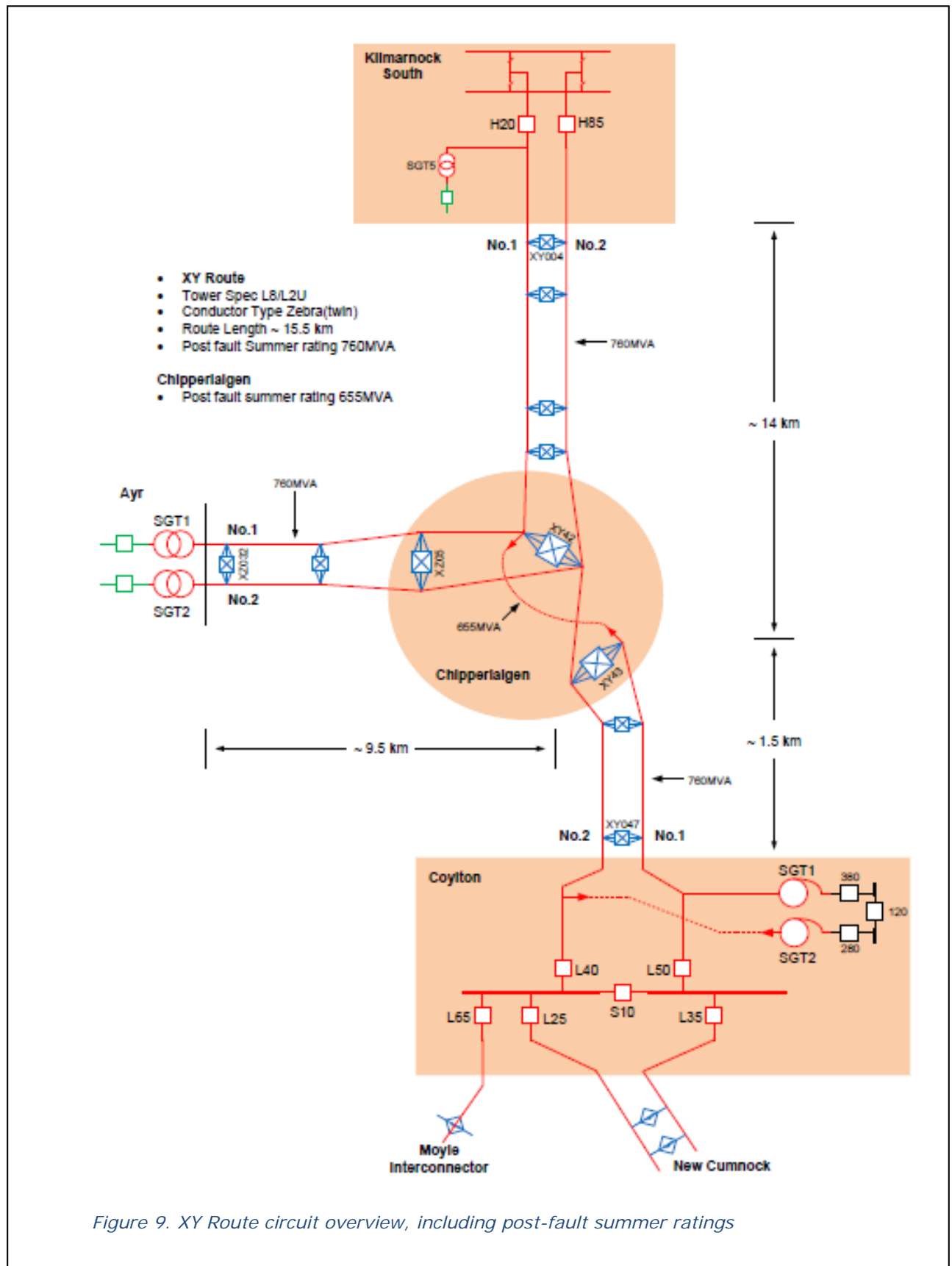

Figure 9. XY Route circuit overview, including post-fault summer ratings

Transmission Owner Innovation Roll-Out Mechanism Submission Pro Forma

Section 2: Application Description continued

The uprating works will replace the existing double-circuit twin ACSR Zebra conductors between Coylton and Kilmarnock South with double-circuit twin ACCR Drake. The OHL circuits will be reconducted in independently in consecutive years, starting in the 2015 outage season, in order to synergise the commissioning date with the YY route. The GIS installation will be commissioned in October 2016.

Table 5 details the resultant increase in circuit capacity. The main reconducting work (thus the outage) will take place between July-November 2015 and April-October 2016, with preparatory site access works underway from May 2015. The programme of the stringing works is provided in Appendix D.

Table 6. Increased XY circuit ratings using ACCR HTLS (Drake) per circuit (twin bundle)

Type	Pre-Fault Continuous Summer Rating	
	Amps	MVA
Zebra 2x400mm ² ACSR @75°C (Existing)	1340	640
Rubus 2x500mm ² AAAC @90°C	2430	1160
Drake 2x418mm ² ACCR @210°C	3360	1600

2.9 Schedule of costs

The schedule of the uprating works on both circuits, and the requested IRM adjustment values (less the XY Route business plan allowance) are set out below.

The 2015/16 costs attributed to the YY Route are incurred as the conductor purchase for both routes were combined to achieve greater value for money. Expenditure prior to 2015 cover the technical design and planning of the projects.

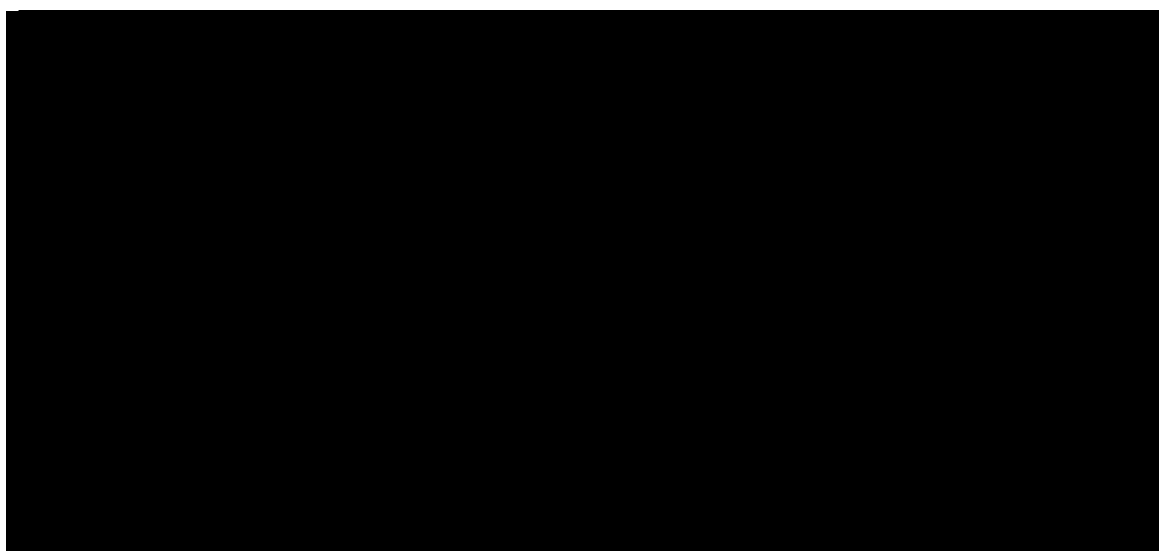

Figure 10. Cost profile and proposed IRM adjustment value

Transmission Owner Innovation Roll-Out Mechanism Submission Pro Forma

Section 3: Application Business Case

Section 3: Application Business Case

The Cost Benefit Analysis (CBA) model proposed by Ofgem has been adopted to illustrate the options available for achieving the necessary capacity increase. This section provides a narrative to the CBA and summarises the findings.

In order to provide a fair reflection of the benefits of both single-circuit and double-circuit deployment, a CBA model has been produced for both single-circuit (CBA-1) and double-circuit (CBA-2) uprating. The purpose of this analysis is to demonstrate the justification for the preferred solution.

Brief descriptions of the other alternative reinforcement options that were considered but not costed are also included within the Options sheet of the CBA model.

3.1 Assumptions

The assumptions within the CBA are summarised here

- A common generation case is presented for both models and the capacity MVA requirements (MVA) are calculated by allowing minimum power factor and voltage of 0.95 p.u

$$\text{Capacity MVA} = \text{Generation MW} / (0.95 * 0.95)$$

- Carbon Savings are calculated based on displacing conventional generation using DEFRA's carbon emissions equivalent per unit electricity generation

$$\text{CO}_2\text{e} = 0.49426\text{kg per kWh}$$

DEFRA 2014, <http://www.ukconversionfactorscarbonsmart.co.uk/>

- 
- Large cost items, such as Tower Replacement/Reinforcement and Civil Engineering (site access etc.), are drawn from best engineering judgement informed by previous similar projects.
- Planning delays of major tower build across Galloway Forest Park, estimated to amount to 8 years, on the assumption that a public enquiry would ensue.
- Training costs of HTLS are based on hire of National Grid's Training Centre at Eakring, purchase of 2km of ACCR HTLS conductor from 3M, and the development of associated training course.

Transmission Owner Innovation Roll-Out

Mechanism Submission Pro Forma

Section 3: Application Business Case continued

3.2 Generation Modelling

In order to assess the benefits of each option, the existing and contracted generation is modelled, along with the potential for additional future generation in the region to assess the impact on capacity headroom. The generation case used to forecast the necessary circuit capacity for both CBA models is shown in Table 6.

As the recent increase in renewable generation is largely driven by many external forces the potential generation beyond 2025 is not considered, especially given the political uncertainty surrounding generation, interconnection, and the future of the UK generation mix.

Table 7. Generation case used in CBA simulations

Site	Collector substation	Capacity (MW)	Partial (%)	Partial Date	Full (%)	Full Date
New WF A (Mark Hill)	Mark Hill	150			100%	2019
New WF B (Mark Hill)	Mark Hill	50	25%	2021	100%	2025
New WF C (Coylton)	Coylton	200	50%	2021	100%	2025

The partial capacity date enables modelling of a step-change in connected generation, and alterations to generation output [REDACTED]

In addition to the contracted generation feeding the Mark Hill and Coylton substations the generation case includes forecasted capacity in the form of three sites (highlighted). The “New WF” sites allow forecasting of increased capacity into Mark Hill and Coylton independently and offer a degree of sensitivity analysis.

The figures above are simulated to formulate a comparison between the uprating options and are not based on consented generation expected to connect during the current price control. [REDACTED]

Transmission Owner Innovation Roll-Out Mechanism Submission Pro Forma

Section 3: Application Business Case continued

3.3 The single circuit CBA, the YY Route

The cost benefit analysis depicts the followings options to uprate the circuit:

- i. Install a parallel single-circuit with single ACCC Rubus
- ii. Replace single 500mm² ACCC Rubus conductors with gap-type GZTACSR HTLS
- iii. Replace single 500mm² ACCC Rubus conductors with ACCR HTLS**

In compiling the CBA we have considered the likely options for reinforcement, as were identified at the technical design stage (prior to submitting a connection offer). The indicative costs of these options are set out below.

Table 8. Breakdown of project costs and capacity release from single circuit CBA

	Option 0	Option 1	Option 2
	New Single Circuit - 500mm Rubus ACCC	Single 620mm Matthew GZTACSR	Single 525mm Curlew ACCR
Cost Item	Cost £m	Cost £m	Cost £m
Conductor Purchase	█	█	█
Design and Build	█	█	█
Legal & Planning	█	█	█
Risk	█	█	█
Total Cost	█	█	█
Capacity increase (MVA)	504	351	420
£k/MVA increase	█	█	█
Outage period (months)	24	7	5
Commissioning Date	2024	2016	2016
NPV (£m) 6yrs		-£3.55	-£3.44
NPV (£m) 40yrs		£6.36	£6.71

The CBA compares the cost of building a new single circuit and also the difference between the two candidates for high-capacity high-temperature operation. In scoping solutions to the single-circuit dilemma, the high cost of building a new line and the inevitably distant commissioning date constituted as highly undesirable and were key motives that led SPT to investigate the HTLS technology, beginning with the GZTACSR in particular.

During the initial design stages, consultations with the SO and connected users regarding a potential 7 month outage led to the need for a reduced window. SPT commissioned a study into the new ACCR HTLS which eventually amounted to a report detailing a quicker delivery of the YY Route uprating using ACCR HTLS conductors, supplied by 3M (see report summary in Appendix E). Therefore, whilst the implementation of two HTLS technologies may have comparable costs the reduction in outage time, from 7 months to 5 months, marks a notable improvement.

Transmission Owner Innovation Roll-Out Mechanism Submission Pro Forma

Section 3: Application Business Case continued

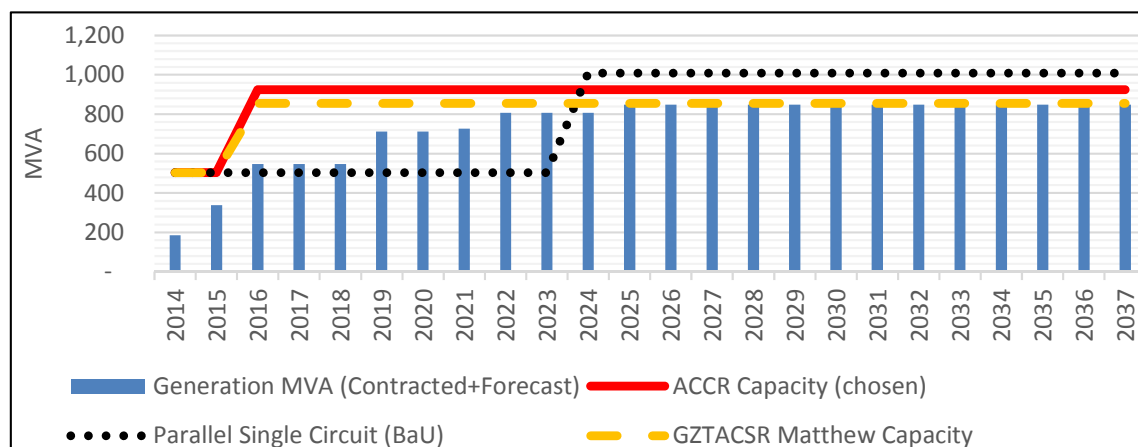

Figure 11. CBA-1 capacity outputs, chosen ACCR Curlew versus baseline new build

As shown in Figure 11, the baseline option (Option 0) to install a single circuit in parallel would provide greater capacity but at a much later date and for inferior value for money, i.e. pound-per-MVA. Furthermore, an additional circuit will positively benefit the generators and the Moyle Interconnector, with a negligible, if not negative, benefit to end electricity customer.

We have valued the financial benefit of the outage reduction by two months by considering a subsequent reduction in payments under the Renewable Obligation Certificate (ROC), consistent with previous such assessments. The 2014/15 ROC buy-out price is £43.30 per 1MWh from onshore wind equals 0.9 ROCs. For a 2 month outage on the YY Route with 167MW wind generation interrupted, equates to a cost of

$$64,930\text{MWh} \times 0.9 \times £43.3 = £2.53\text{m}$$

An installation delay of 8 years is modelled (due to acquiring planning permission) and considered highly likely, at a minimum, based on past experience of that route. Under these circumstances, approximately 300MW of renewable generation would not be able to connect during RIIO-T1, and the potential investment maybe withdrawn altogether.

Moreover, the loss of potential carbon savings can therefore be calculated assuming that 300MW of wind generation would generate 700GWh per annum which, if displaced by conventional generation, would equate to up to 300,000 tonnes CO₂e per annum.

A summary of the benefits of adopting ACCR versus rebuilding/reinforcing YY Route:

- Saving over £43m by avoiding major tower works
- Accelerated connection of 300MW of wind generation
- Saving an estimated 1.5Mtonnes of GHG emissions by 2023, attributable to anticipated delayed connection of 300MW of wind generation by 8 years.

The superior capacity, relative cost and simplicity of installation of the ACCR HTLS are the decisive factors in choosing the HTLS option, and are strong enough to outweigh the associated uncertainties, risks and inexperience of the unfamiliar ACCR technology.

Transmission Owner Innovation Roll-Out

Mechanism Submission Pro Forma

Section 3: Application Business Case continued

3.4 The double-circuit CBA, the XY Route

The cost benefit analysis for the XY Route is slightly more complicated than the single-circuit YY Route given the scale and uncertainty of the potential generation in the region, although the BaU option would in fact also require a new circuit in parallel. The following options have been considered to provide the necessary capacity:

- i. Rebuild a new double circuit in parallel with the existing route, twin 500mm² ACCC Rubus
- ii. **Reconductor twin 400mm² ACSR Zebra with Twin 418mm² ACCR Drake**

For illustration purposes, the original SWS proposal is also included:

- iii. Reconductor twin 400mm² ACSR Zebra with Twin 500mm² ACCC Rubus

As detailed previously, the reconductoring of the XY Route was envisaged as part of the wider SWS Project (a non-TIRG element) whereby the conductors would be upsized from twin 400mm² Zebra to twin 500mm² Rubus AAAC. This option is no longer suitable as it does not provide sufficient uprating, however, it is included for reference.

As the heightened capacity requirements cannot be met using ACCC conductors without rebuilding the existing towers, the most suitable BaU option is to build a new double circuit in parallel to the existing route. A breakdown of the costs from the double-circuit CBA are set out below.

Table 9. Breakdown of project costs and capacity release from double-circuit CBA

	Option 0	Option 1	Option 2
	New Double Circuit - 2x500mm Rubus	Double Twin 418mm Drake	Double Twin 500mm Rubus (inadequate)
Cost Item	Cost £m	Cost £m	Cost £m
Conductor/Tower Purchase	█	█	█
Design and Build	█	█	█
Legal & Planning	█	█	█
Outage Costs (SPT & Gen)	█	█	█
Total Cost	█	█	█
Capacity increase (MVA)	2,320	1,960	1,040
£k/MVA increase	█	█	█
Commissioning Date	2023	2015	2015
NPV (£m) 6yrs		-£3.60	-£2.52
NPV (£m) 40yrs		£6.94	£10.12

Note, the baseline costs of building a new double circuit are derived from the cost assessment used in the single circuit CBA, and scaled down in respect of the number of towers and length of conductors. The figure of £42m is purely indicative, and SPT would expect the actual cost to be greater give the increased tower size, foundation works, and, in view of recent works, a potentially more costly planning procedure.

Transmission Owner Innovation Roll-Out Mechanism Submission Pro Forma

Section 3: Application Business Case continued

The superior capacity offered by the HTLS conductor is evident in Figure 11 below, which compares the capacity provided by the three options in relation to the potential capacity required.

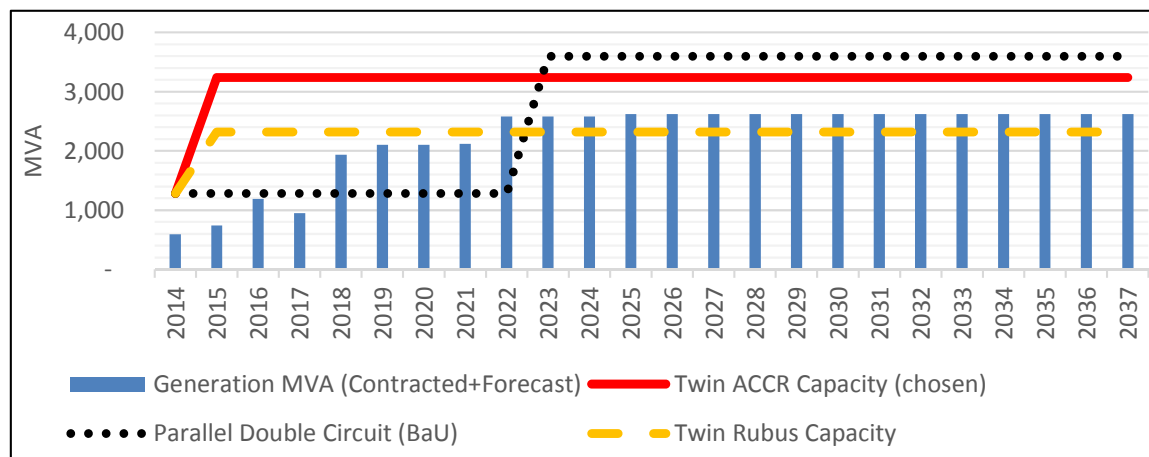

Figure 12. CBA-2 capacity outputs, chosen ACCR Drake versus new parallel circuit and twin Rubus option anticipated within the SWS Project set out in the Business Plan.

The figure above demonstrates the advantage of the high capacity conductor with the ability to deliver quicker and greater capacity release than the alternative conventional options, and also highlights a key challenge facing SPT in delivering network reinforcement efficiently to accommodate the volatile wind generation market.

The CBA models the generation capacity requirements according to the SO Ranking Order0 and as a portion of this generation is subject to consent, the scale and timing of the generation sites are subject to change. Given that the option to reconductor the using AAAC does not provide sufficient capacity, the next preferred conventional option is to build an additional circuit (set as the CBA baseline option).

In opting for the HTLS solution, and avoiding the need to build a new circuit alongside the XY Route, the potential steelwork and concrete reduction can be estimated in the order of 1,000 and 8,500 tonnes, respectively. Calculation details can be found in Environmental sheet of the CBA model.

The CBA model calculates the carbon emissions based on the level of generation that would otherwise be supplied by conventional generation. The absence of planning and building a new circuit means that no significant potential carbon savings would accrue by deploying a different type of conductor on double-circuit reinforcement scheme.

A summary of the benefits of adopting ACCR versus rebuilding/reinforcing XY Route:

- Saving of £19m in comparison to the BaU option,
- Vital in the facilitation of [REDACTED] wind generation into Coylton collector substation, and enabling an estimated total export from the region of 1.7GW by 2021 (and 2.1GW by 2023).

Transmission Owner Innovation Roll-Out Mechanism Submission Pro Forma

Section 3: Application Business Case continued

3.5 Overall CBA conclusion

The superior capacity, simplicity of installation, value for money, and avoidance of planning permission are the decisive factors in choosing the HTLS reconductoring option over the BaU alternatives, and are strong enough to outweigh the associated uncertainties, risks and inexperience of the unfamiliar ACCR technology.

By coordinating the combined reinforcement of the XY and YY Routes, SPT will take learning from the first installation stage in 2015 into the second stage in 2016 and minimise the necessary outage time affecting users on the single-circuit connection.

The high capacity offered by HTLS technology allows SPT to efficiently manage uncertainties impacting the generation and consenting background, and bide valuable time in enabling SPT to evaluate the true level of the reinforcement required and optimise the effectiveness and efficiency in future network reinforcement judgment.

Transmission Owner Innovation Roll-Out Mechanism Submission Pro Forma

Section 4: Evaluation Criteria

Section 4: Evaluation Criteria

The intention of the IRM is to overcome commercial barriers that may exist to the TO that within the present Price Control (i.e. the lack of financial incentives and level of risk) and encourage Transmission Network Owners to implement new proven technologies that will deliver long-term value for customers but do not, currently, form part of Ordinary Business Arrangements.

The Transmission Licence Special Condition 6E sets the four main criteria to which the Authority will assess IRM application;

- a) will deliver Carbon Benefits or any wider environmental benefits;*
- b) will provide long-term value for money for electricity consumers;*
- c) will not enable the licensee to receive commercial benefits from the Roll-out within the remainder of the Price Control Period (for instance, where the Roll-out of a Proven Innovation will lead to cost savings (including benefits from other incentives) equal to or greater than its implementation costs within the Price Control Period); and*
- d) will not be used to fund any of the Ordinary Business Arrangements of the licensee.*

The section will provide supporting information to demonstrate how the proposed scope of works will fulfil each of the above criteria.

Transmission Owner Innovation Roll-Out Mechanism Submission Pro Forma

Section 4: Evaluation Criteria continued

4.1 Criteria A - Delivering Carbon Benefits and wider environmental benefits

The deployment of the HTLS conductor on the proposed routes will deliver both carbon and environmental benefits by using lightweight high-capacity conductors to facilitate and accelerate the connection of the thriving wind generation market and using less concrete and steel in the process.

4.1.1 Carbon benefits

In order to quantify the carbon benefits we consider the renewable generation connected and further capacity released, and propose some assumptions on the increased generation connected as a result of these works.

As the reinforcement is driven by the need to connect additional renewable generation, the capacity of this new generation is used to calculate the displaced carbon emissions that would otherwise be fulfilled by conventional generation. Given the generation is set to increase by 326MW and 1,034MW for the YY Route and XY Route, respectively, the total combined thermal generation displaced equates to 1.5Mt CO_{2e} per annum.

$$YY: 326\text{MW} \times 8760 \times 0.27\% = 771\text{MWh} \times 494\text{kg/MWh} = 0.38\text{Mt CO}_2\text{e per annum}$$

$$XY: 1034\text{MW} \times 8760 \times 0.27\% = 2445\text{MWh} \times 494\text{kg/MWh} = 1.2\text{Mt CO}_2\text{e per annum}$$

The above calculations show the indicative annual carbon benefits but do not reflect the actual forecast generation profile. Whilst the figures above illustrate the scale of the potential carbon savings more accurate calculations used in the CBA models are shown below, which take into account the timing and the eventual BaU solution.

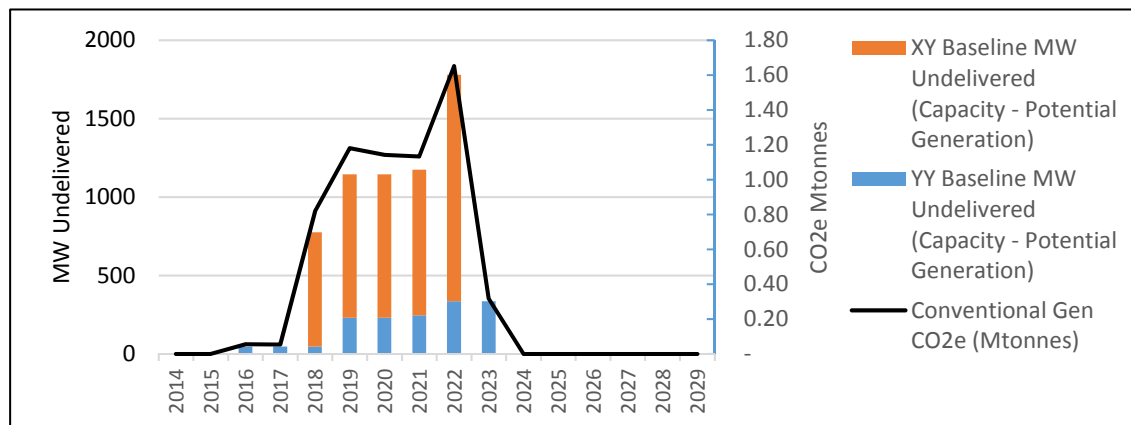

Figure 13. Estimated carbon savings by chosen HTLS solution instead of new circuit

Conventional means of uprating the circuit would require major tower works with a lead time of at least 5-8 years longer than attainable through reconductoring. The delayed connection consequently results in a degree of 'lost' carbon savings.

The CBA models estimate that the reconductoring using HTLS technology will deliver a total saving of 6.36Mt CO_{2e} until the BaU solution is delivered. This figure is calculated by considering the generation capacity that is forecast to connect above the BaU installed circuit capacity.

Transmission Owner Innovation Roll-Out Mechanism Submission Pro Forma

Section 4: Evaluation Criteria continued

The calculations indicate the direct carbon benefits enabled by this project that would also be delivered by the BaU approach, albeit at a later date. Whilst it might therefore seem logical to conclude that only the incremental carbon benefit should be considered, SPT would highlight that the increased cost and delayed connection date of the BaU approach would not be suitable for some generation schemes, therefore it is highly likely that the incremental carbon benefit would likely be in excess of the figure stated above.

4.1.2 Potential Steelworks and Concrete savings

The CBA models also include a calculation estimating the level of steelwork and concrete saved by using existing towers rather than build new circuits. The all-aluminium ACCR HTLS technology also means that the towers do not need reinforcement, where other HTLS technology may.

The calculated savings in terms of avoided steel and concrete are tabulated below.

Table 10. Steel and concrete savings achieved by avoiding new towers

Savings	YY Route	XY Route	Units
Tower Steelwork to be Replaced	2970	1148	Tonnes
Concrete to be Installed	10844	3352	m3
	27628	8540	Tonnes
Ground to be Excavated	47520	14688	m3
	75977	23484	Tonnes

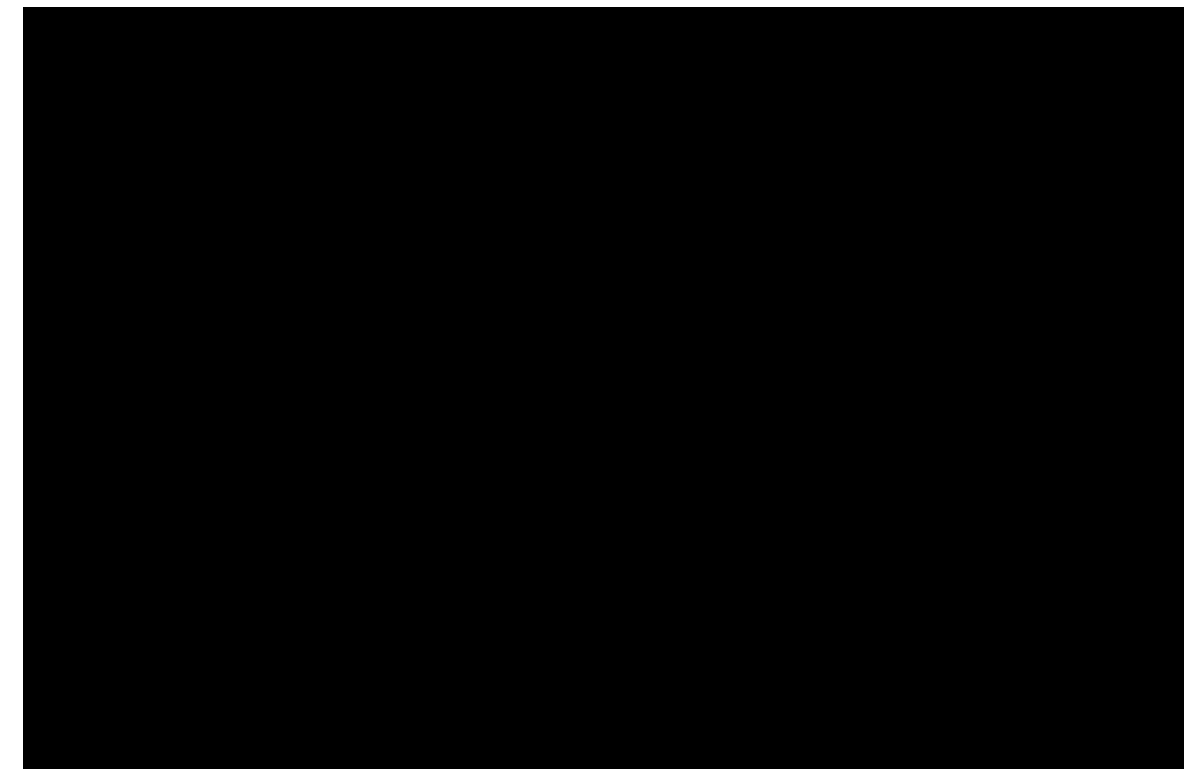

Transmission Owner Innovation Roll-Out

Mechanism Submission Pro Forma

Section 4: Evaluation Criteria continued

4.2 Criteria B - Providing long-term value for money for electricity consumers

The roll-out of a proven innovation through the IRM should deliver additional and significant benefits for customers. It should not lead to licensees making additional profit or be used to fund activities that are already business as usual or have been funded through the price control.

The long-term value for money achieved by introducing higher-capacity conductors offering twice the capacity of conventional technology into the system planning and design engineer 'toolbox' is unquestionable. The funding through the IRM will provide SPT with the learning and experience gained through the first installation of its kind, introducing the principles and procedures behind the implementation and maintenance and providing accurate project cost / unit cost information to inform decision-making for future projects.

The cost of HTLS technology is the prohibitive factor in its uptake, especially in regards to new build investment projects, but it is conductor replacement schemes where HTLS technology is most attractive – offering the possibility for greater capacity per circuit without major tower or foundation works. This project will allow the business gain familiarisation of the technology, generating experience and confidence.

Once the overall cost of implementing HTLS solutions are well understood and part of a design engineer's arsenal, case-by-case assessments will ensure future reinforcement and new-build investments can be better optimised in terms of technical and financial efficiency. Through the increased implementation of the technology, it would be reasonable to also anticipate the cost of HTLS to decline – further improving the supporting business case and, ultimately, improving value for money per MVA.

In cases where tower replacement works can be avoid altogether a significant reduction in investment costs can be realised. The CBA analysis of the schemes indicates that by avoiding the replacing or building new towers in parallel, approximately £60m of investment is avoided, along with a wealth of additional benefits that are otherwise depleted by building a new circuit – environmental impact, legal fees, public enquiries, operational costs and opportunity cost of potential renewable generators.

In other cases, the increased cost of the HTLS conductors can be offset by the avoidance of tower strengthening works, where circuit capacity can be doubled without putting additional concrete in the ground, offering a more environmentally friendly and straightforward method of delivering capacity uprating.

The overall widespread deployment of HTLS conductors in place of the industry standard AAAC conductors is not currently viable. Scenarios where HTLS technology represents a significant saving versus the BaU approach are rare, and HTLS is still very much an unknown quantity and its application is restricted by lack of experience. It is SPT's belief that only through actual deployment will the technology be effectively integrated into standard business practices, and through increased implementation further value-for-money can be derived.

Transmission Owner Innovation Roll-Out Mechanism Submission Pro Forma

Section 4: Evaluation Criteria continued

In summary, this project represents long-term value for money for electricity in the following ways:

Direct benefits

- For the YY Route: Reducing cost by over £43m in order to satisfy renewable connection obligations by avoiding the construction of a new 275kV circuit. Improving the value for money per capacity release by £75k/MVA compared to BaU.
- For the XY Route: Reducing cost by approximately £19m to increase capacity on primary exit route for generation in the South West of Scotland. Improving the value for money per capacity release by £6k/MVA compared to BaU.

Longer-term benefits

- Integrating the new high-capacity technology into standard business practices to become a standard tool used in assessing the most effective and economical solutions for future investments.
- SPT have already set out initial designs to include ACCR HTLS technology as part of future projects pending the successful completion of the works set out in this document.
- For every avoided new circuit built, SPT expect to achieve savings between £20m - £40m, and do so without causing public dissatisfaction.

Transmission Owner Innovation Roll-Out Mechanism Submission Pro Forma

Section 4: Evaluation Criteria continued

4.3 Criteria C - Will not enable the licensee to receive net commercial benefit within RIIO-T1

The IRM project will enable more renewable generators to be connected to the transmission network quicker and cheaper than building a new circuit or undertaking tower steelwork and foundation reinforcement works.

The adoption of the proven innovation will incur no fundamental changes to business practices or to revenue streams as a result of this project. By effectively replacing an old technology with a new one, SPT will be in a position to reduce costs by offering high-capacity conductors on low-capacity towers.

Any allowances made in the current Price Control Period have been subtracted from the proposed IRM adjustment value. SPT will not receive any commercial benefits greater or equal to the funding sought.

Transmission Owner Innovation Roll-Out Mechanism Submission Pro Forma

Section 4: Evaluation Criteria continued

4.4 Criteria D - Will not be used to fund any of the Ordinary Business Arrangements

Historically, new conductor systems have arisen in 30-50 year intervals; ACSR in the 1920's, AAAC in the 1970's and recently the move to high temperature conductors. Given the breadth of time between evolutions of conductor systems, in-house experience is non-existent and the integration process is therefore essentially reinvented.

Integrating the new HTLS conductor system into the business involves many non-trivial processes, including developing a design standard specification and production of internal process documentation. The business routinely introduces state-of-the-art equipment and software into its substations, SCADA platforms and IT systems, but progression to a new conductor system marks a significant technological leap that should not be misconstrued as an Ordinary Business Arrangement.

To support this, we consider Ofgem's definition:

Ordinary Business Arrangement -

means any or all of the following: (a) a specific piece of existing Network Equipment; (b) an arrangement or application of existing Network Equipment; (c) an operational practice; (d) a commercial arrangement, that is being used or is capable of being used, without modification, by the licensee or another Transmission Owner at the start of the Price Control Period.

The argument could be raised that new HTLS conductor constitutes as a piece of existing Network Equipment, in so much that it is an overhead line conductor that operates at a high temperature. This argument overlooks the level of the complexity and technical assurance, and the necessary rigorous approval process therefore, before an asset can be considered for installation on the transmission network and maintained for 40-60 years.

Introducing and integrating the technology into the business is a convoluted process. The key stages SPT have undertaken, or will undertake, before the HTLS could be installed for the first time are:

- International implementation and performance review
- National Grid and SHETL testing and installation of gap-type ACSR HTLS
- National Grid offline installation of ACCR HTLS and performance review
- Assessment and recommendation of HTLS technology suitable for SPT
- Development of Design Specification Standard, based on CIGRE working group 426 and National Grid type registration NGS4.3.2
- Development of Installation and Maintenance Operations Manual

Transmission Owner Innovation Roll-Out Mechanism Submission Pro Forma

Section 4: Evaluation Criteria continued

- Scoping and Coordination of staff training, including Full System Training.
- Type Registration of the conductor and all associated fittings

HTLS technology is widely accepted as the next generation of conductor system to replace AAAC technology. SPT's Head of Overhead Line Engineering has followed the progress of HTLS for many years and has held discussions with international suppliers and customers as different HTLS technologies have developed and progressed onto the global market.

In addition, National Grid and Scottish Hydro Electric have been actively engaged by their sharing experience and knowledge gained through trials of the gap-type HTLS and, more recently, offline testing of the ACCR HTLS funded through IFI/NIA.

The engagement with the UK and international market has accumulated in SPT's evaluation of HTLS technology (Appendix C), whereby ACCR, and in particular the 418mm² Drake and 525mm² Curlew varieties, are recommended as a direct replacement for the existing fleet of ACCC 400mm² Zebra and 500mm² Rubus.

It is SPT's belief that the new ACCR conductor system can only be considered as an existing asset following the successful procurement, type registration, staff training and site installation of the technology, from which future unit costs and design planning can be derived.

Transmission Owner Innovation Roll-Out Mechanism Submission Pro Forma

Section 5: Regulatory Issues

Section 5: Regulatory Issues

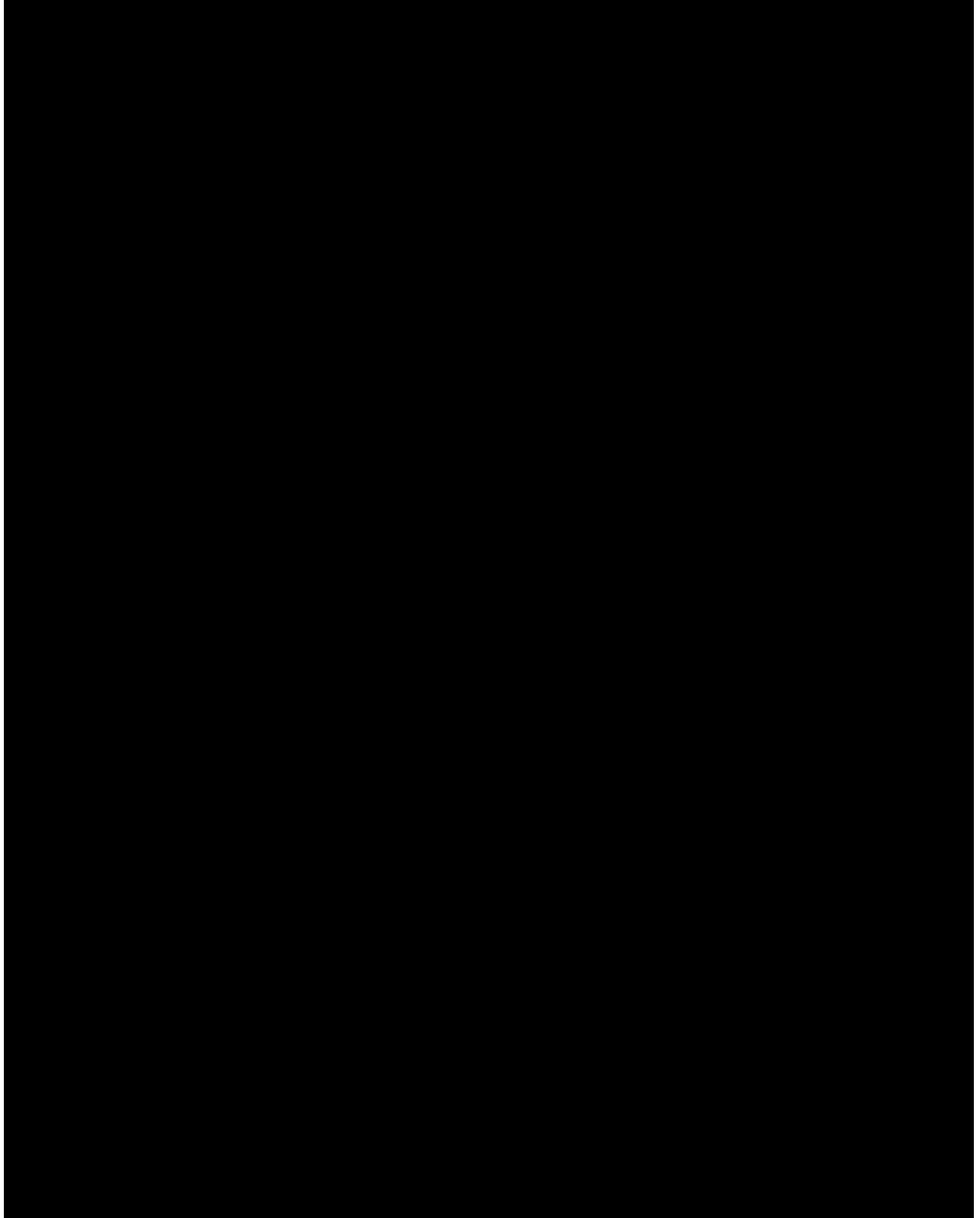

Transmission Owner Innovation Roll-Out Mechanism Submission Pro Forma

Section 5: Regulatory Issues continued

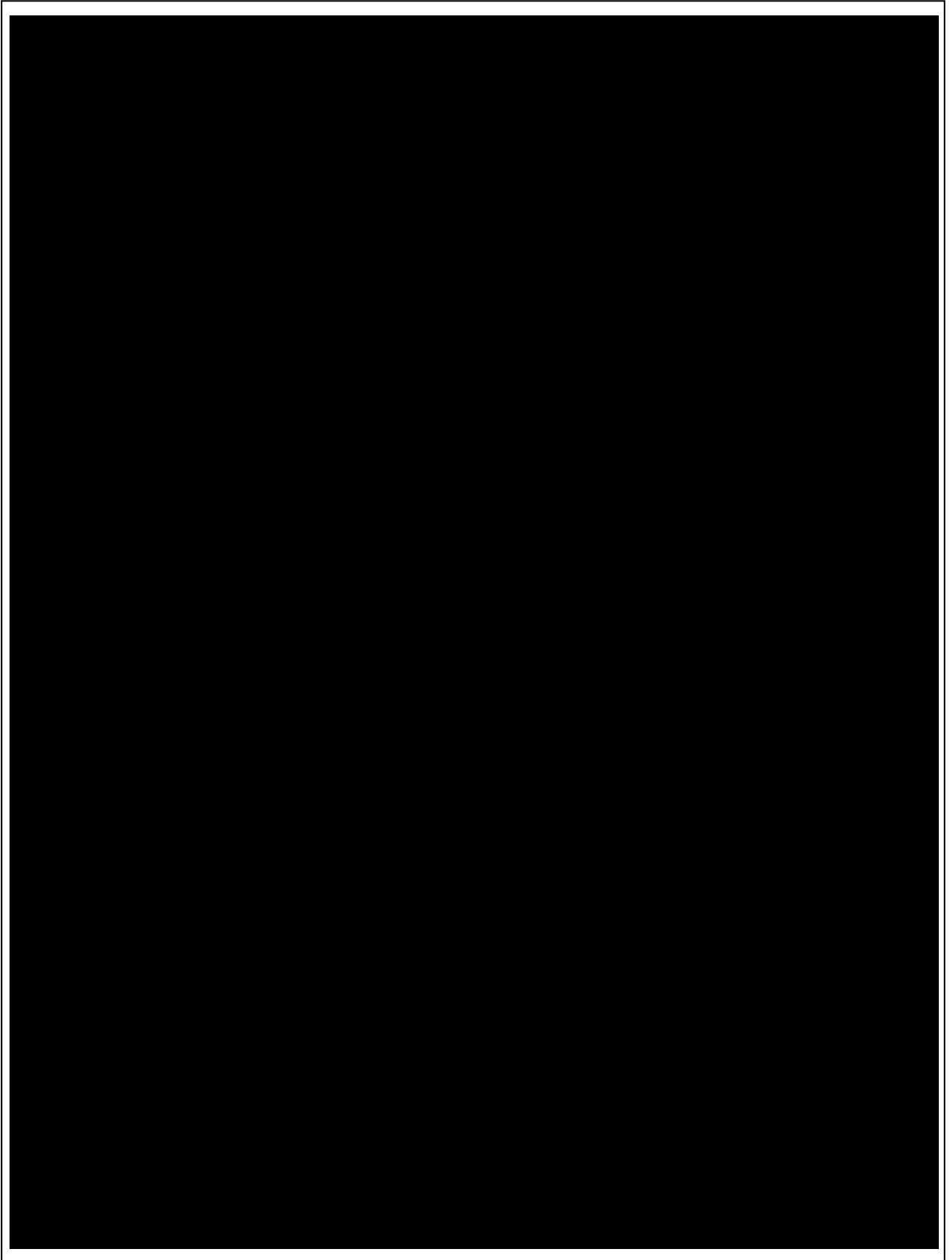

Transmission Owner Innovation Roll-Out Mechanism Submission Pro Forma

Section 5: Regulatory Issues continued

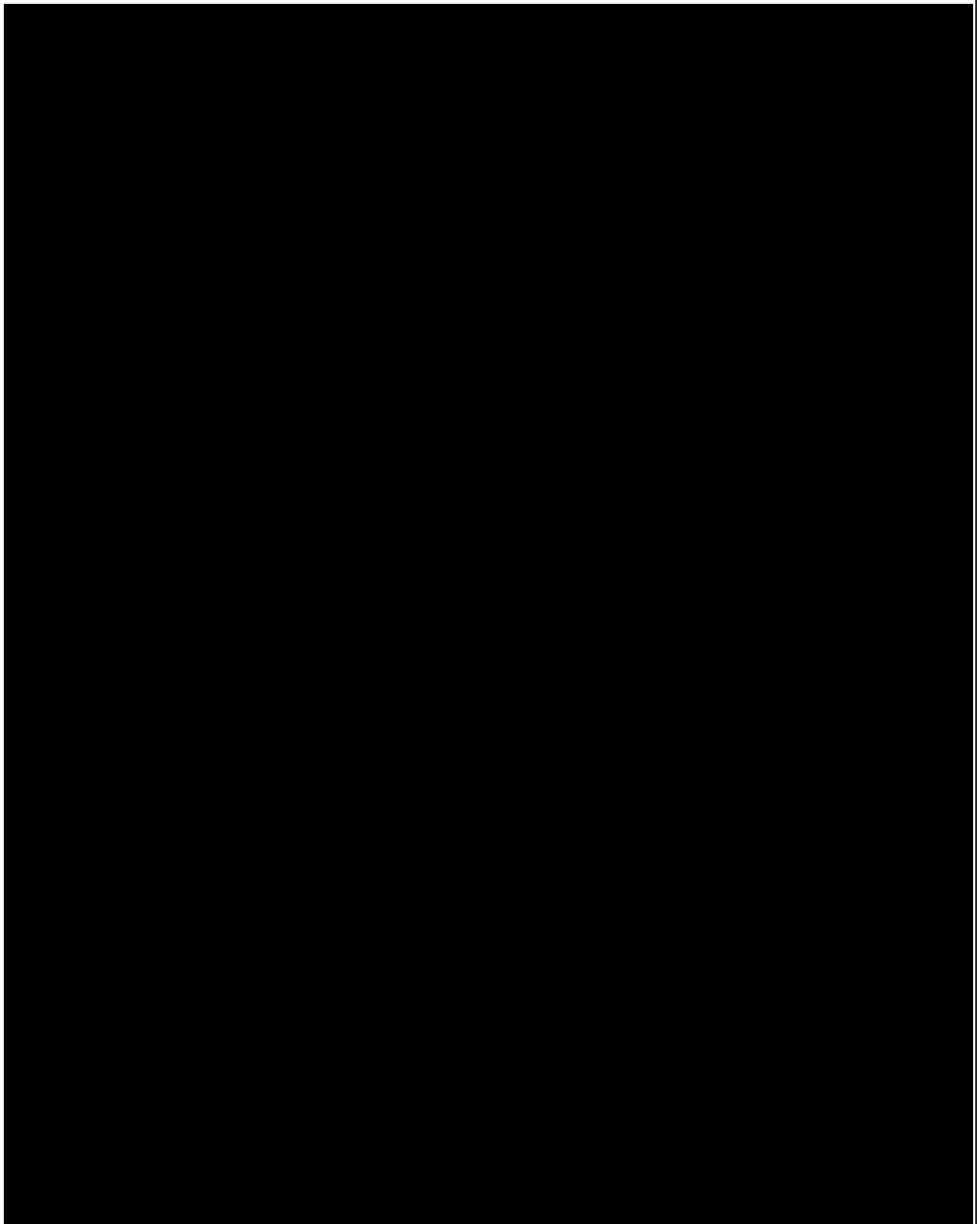

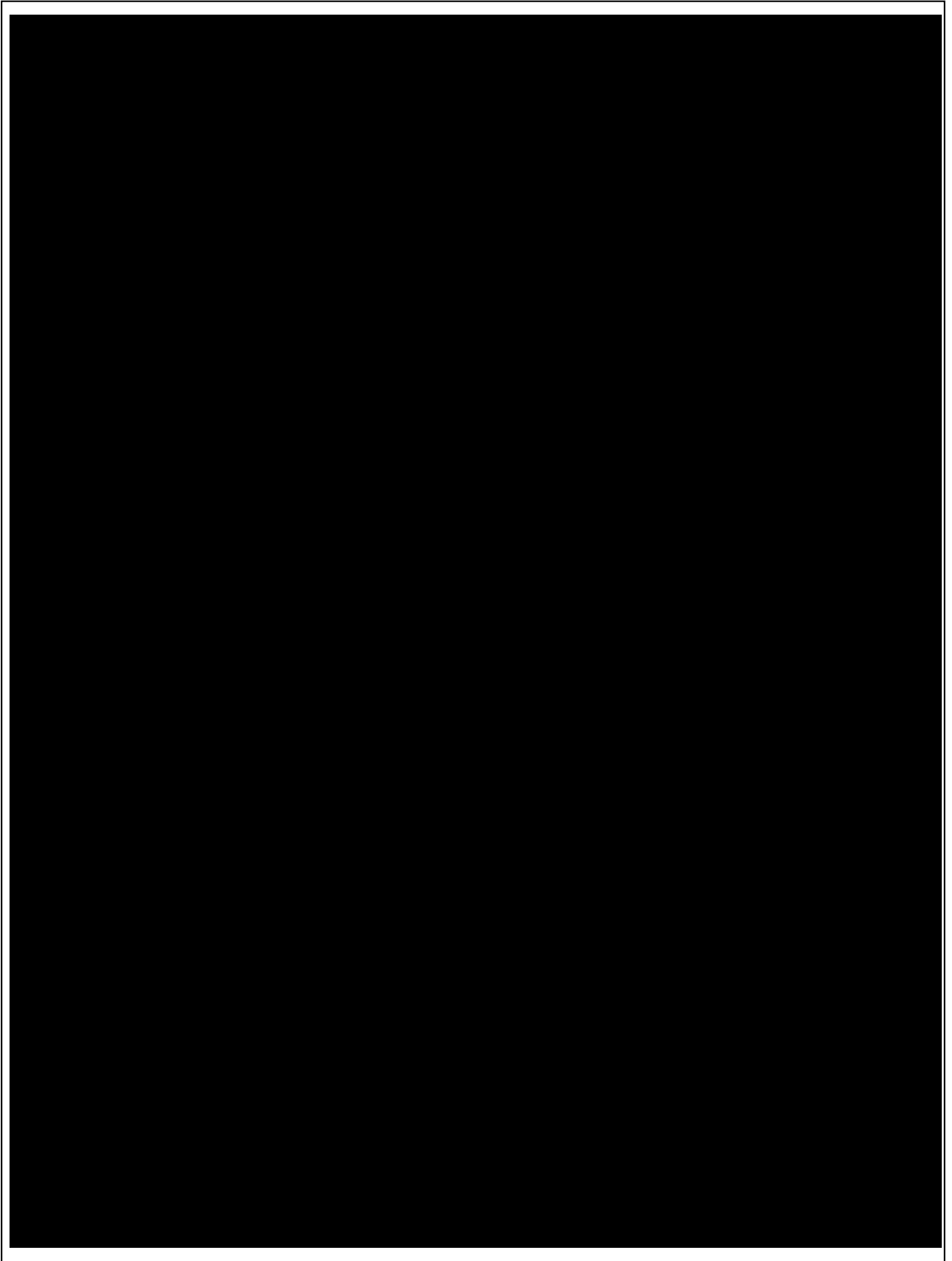

Transmission Owner Innovation Roll-Out Mechanism Submission Pro Forma

Section 5: Regulatory Issues Continued



Transmission Owner Innovation Roll-Out Mechanism Submission Pro Forma

Section 6: Appendices

	<h3>Annual IFI Report</h3>																																														
<table border="1" style="width: 100%; border-collapse: collapse;"> <tr> <td style="background-color: #4F81BD; color: white;">Project title</td> <td colspan="4">Trial & Performance Assessment of ACCR Conductor (3M)</td> </tr> <tr> <td style="background-color: #4F81BD; color: white;">Project Engineer</td> <td colspan="4">Mike Fairhurst</td> </tr> <tr> <td style="background-color: #4F81BD; color: white;">Description of project</td> <td colspan="4"> <p>Assess the suitability of the new generation of high temperature low sag overhead line (OHL) conductors currently available on the market, for deployment on the UK transmission network, in terms of mechanical capability & performance, erection methods, maintenance & repair.</p> <p>At present National Grid have installed both GAP and ACCC (CTC) conductors on the bottom & middle phase on the de-commissioned YYO line near Sheffield in order to evaluate the mechanical performance.</p> <p>The goal of this project is to string ACCR (3M) on the remaining top phase in order to evaluate and compare the stringing, sagging and termination of these three high temperature low sag (HTLS) conductor types, to monitor their mechanical behaviour during simulated ice loading conditions and to evaluate the practical application of the three.</p> <p>HTLS conductors and their component materials have been extensively tested both during and after their development by the manufacturers and various research organisations, but to date National Grid have yet to carry out such works.</p> </td> </tr> <tr> <td style="background-color: #4F81BD; color: white;">Expenditure for financial year 11/12</td> <td>Internal £21k</td> <td>Expenditure in previous (IFI) financial years</td> <td>Internal £5</td> <td>External £150</td> </tr> <tr> <td></td> <td>External £22k</td> <td></td> <td>External £150</td> <td></td> </tr> <tr> <td></td> <td>Total £42k</td> <td></td> <td>Total £155</td> <td></td> </tr> <tr> <td style="background-color: #4F81BD; color: white;">Total project costs (collaborative + external + [company])</td> <td>£385k</td> <td>Projected 2013/14 costs</td> <td>£0k</td> <td></td> </tr> <tr> <td style="background-color: #4F81BD; color: white;">Technological area and/or issue addressed by project</td> <td colspan="4"> <p>There are many sorts of power flow limitation in modern power systems. If the problem can be solved by a relatively large increase in the thermal rating of an overhead line, re-conductoring the line with HTLS conductor is a possible solution. These conductors are capable of high temperature operation with minimal change in electrical and mechanical properties and have low sag at high temperature when compared to conventional conductors.</p> <p>In order to increase a line's thermal rating without rebuilding or replacing its structures and foundations, the original conductor can be replaced with a special high-temperature, low-sag (HTLS) conductor having the similar dimensions and properties as the original, but which can be operated safely and reliably at much higher temperatures with far greater ampacity.</p> <p>ACCR conductor has over 10 years service history with no reported failures in service and no failures during installation. To date there are 90 successful installations, in over 60 different countries, with more scheduled for 2011, 2012 & 2013. With the most recent installation being in National Grid USA, as part of the Western Massachusetts Transmission Reinforcement Strategy, 3M are currently investing in expanding manufacturing capacity to meet demand.</p> </td> </tr> <tr> <td style="background-color: #4F81BD; color: white;">Type(s) of innovation involved</td> <td>Significant</td> <td>Project Benefits Rating</td> <td>Project Residual Risk</td> <td>Overall Project Score</td> </tr> </table>			Project title	Trial & Performance Assessment of ACCR Conductor (3M)				Project Engineer	Mike Fairhurst				Description of project	<p>Assess the suitability of the new generation of high temperature low sag overhead line (OHL) conductors currently available on the market, for deployment on the UK transmission network, in terms of mechanical capability & performance, erection methods, maintenance & repair.</p> <p>At present National Grid have installed both GAP and ACCC (CTC) conductors on the bottom & middle phase on the de-commissioned YYO line near Sheffield in order to evaluate the mechanical performance.</p> <p>The goal of this project is to string ACCR (3M) on the remaining top phase in order to evaluate and compare the stringing, sagging and termination of these three high temperature low sag (HTLS) conductor types, to monitor their mechanical behaviour during simulated ice loading conditions and to evaluate the practical application of the three.</p> <p>HTLS conductors and their component materials have been extensively tested both during and after their development by the manufacturers and various research organisations, but to date National Grid have yet to carry out such works.</p>				Expenditure for financial year 11/12	Internal £21k	Expenditure in previous (IFI) financial years	Internal £5	External £150		External £22k		External £150			Total £42k		Total £155		Total project costs (collaborative + external + [company])	£385k	Projected 2013/14 costs	£0k		Technological area and/or issue addressed by project	<p>There are many sorts of power flow limitation in modern power systems. If the problem can be solved by a relatively large increase in the thermal rating of an overhead line, re-conductoring the line with HTLS conductor is a possible solution. These conductors are capable of high temperature operation with minimal change in electrical and mechanical properties and have low sag at high temperature when compared to conventional conductors.</p> <p>In order to increase a line's thermal rating without rebuilding or replacing its structures and foundations, the original conductor can be replaced with a special high-temperature, low-sag (HTLS) conductor having the similar dimensions and properties as the original, but which can be operated safely and reliably at much higher temperatures with far greater ampacity.</p> <p>ACCR conductor has over 10 years service history with no reported failures in service and no failures during installation. To date there are 90 successful installations, in over 60 different countries, with more scheduled for 2011, 2012 & 2013. With the most recent installation being in National Grid USA, as part of the Western Massachusetts Transmission Reinforcement Strategy, 3M are currently investing in expanding manufacturing capacity to meet demand.</p>				Type(s) of innovation involved	Significant	Project Benefits Rating	Project Residual Risk	Overall Project Score
Project title	Trial & Performance Assessment of ACCR Conductor (3M)																																														
Project Engineer	Mike Fairhurst																																														
Description of project	<p>Assess the suitability of the new generation of high temperature low sag overhead line (OHL) conductors currently available on the market, for deployment on the UK transmission network, in terms of mechanical capability & performance, erection methods, maintenance & repair.</p> <p>At present National Grid have installed both GAP and ACCC (CTC) conductors on the bottom & middle phase on the de-commissioned YYO line near Sheffield in order to evaluate the mechanical performance.</p> <p>The goal of this project is to string ACCR (3M) on the remaining top phase in order to evaluate and compare the stringing, sagging and termination of these three high temperature low sag (HTLS) conductor types, to monitor their mechanical behaviour during simulated ice loading conditions and to evaluate the practical application of the three.</p> <p>HTLS conductors and their component materials have been extensively tested both during and after their development by the manufacturers and various research organisations, but to date National Grid have yet to carry out such works.</p>																																														
Expenditure for financial year 11/12	Internal £21k	Expenditure in previous (IFI) financial years	Internal £5	External £150																																											
	External £22k		External £150																																												
	Total £42k		Total £155																																												
Total project costs (collaborative + external + [company])	£385k	Projected 2013/14 costs	£0k																																												
Technological area and/or issue addressed by project	<p>There are many sorts of power flow limitation in modern power systems. If the problem can be solved by a relatively large increase in the thermal rating of an overhead line, re-conductoring the line with HTLS conductor is a possible solution. These conductors are capable of high temperature operation with minimal change in electrical and mechanical properties and have low sag at high temperature when compared to conventional conductors.</p> <p>In order to increase a line's thermal rating without rebuilding or replacing its structures and foundations, the original conductor can be replaced with a special high-temperature, low-sag (HTLS) conductor having the similar dimensions and properties as the original, but which can be operated safely and reliably at much higher temperatures with far greater ampacity.</p> <p>ACCR conductor has over 10 years service history with no reported failures in service and no failures during installation. To date there are 90 successful installations, in over 60 different countries, with more scheduled for 2011, 2012 & 2013. With the most recent installation being in National Grid USA, as part of the Western Massachusetts Transmission Reinforcement Strategy, 3M are currently investing in expanding manufacturing capacity to meet demand.</p>																																														
Type(s) of innovation involved	Significant	Project Benefits Rating	Project Residual Risk	Overall Project Score																																											

Transmission Owner Innovation Roll-Out Mechanism Submission Pro Forma

Section 6: Appendices continued

Annual IFI Report

nationalgrid

	13	1	12
Expected benefits of project	<p>The advantage of the high temperature low sag conductors is their ability to operate continuously at temperatures of 150°C or above with less increase in sag and little or no loss of strength, the net result being increased line rating from existing assets</p> <p>Manufacturer tests of ACCR (3M) indicate that it can be operated at 210°C continuously without changing its mechanical or electrical properties, with a post fault temperature of 240 °C.</p> <p>Providing increased capacity on existing overhead line routes and increased operational flexibility of the network under post fault conditions.</p> <p>The initial cost is considerably more than conventional conductor systems (5 times), however a proportion of this cost will be off set by eliminating the requirement to strengthen existing towers and foundations as is currently the position when existing lines are up-rated, with larger heavier conductors (nominally £30 - £40k per tower), estimated in the forward planning to 2021 as 950 circuit km (nominally 3 towers per km leading to potential £100m saving on towers offset by increased conductor costs resulting in a conservative £10m benefit).</p>		
Expected timescale of project	2 years	Duration of benefit once achieved	8 years
Probability of success	60%	Project NPV = (PV benefits – PV costs) x probability of success	£3,189k
Potential for achieving expected benefits	<p>As stated earlier many countries around the world are adopting this new technology with much design review and testing.</p> <p>With respect to the ACCR (3M) conductor there have been no reported problems since the earliest installation some 10 years ago.</p> <p>National Grid in the US is currently refurbishing and re-conductoring a 110kV line in Massachusetts.</p>		
Project progress [Year to End of March 2012]	<p>The original deployment was to be on a disused section of line (YYO) however site issues led us to abandon that site as the testing facility. As an alternative, the conductor was erected at National Grid training facility at Eakring. All accessories and conductor underwent mechanical testing. National Grid in association with 3M erected the curlew conductor on the top phase of the training line at Eakring with no major issues.</p> <p>Following the initial success of the R&D project, an opportunity arose to erect the same curlew conductor on the High Marnham-West Burton upratings scheme (originally planned for GAP conductor). This presents an ideal opportunity to compare 2 new conductor types as the adjacent Cottam-West Burton circuit is strung with the CTC (ACCC).</p> <p>The 3M conductor is now erected on this circuit, and is due to be commissioned w/c 17th June 2013. Both conductor systems will be monitored simultaneously for medium to long term performance.</p>		
Collaborative partners			

Transmission Owner Innovation Roll-Out Mechanism Submission Pro Forma

Section 6: Appendices continued

6.2 Appendix B: Overview of SWS project

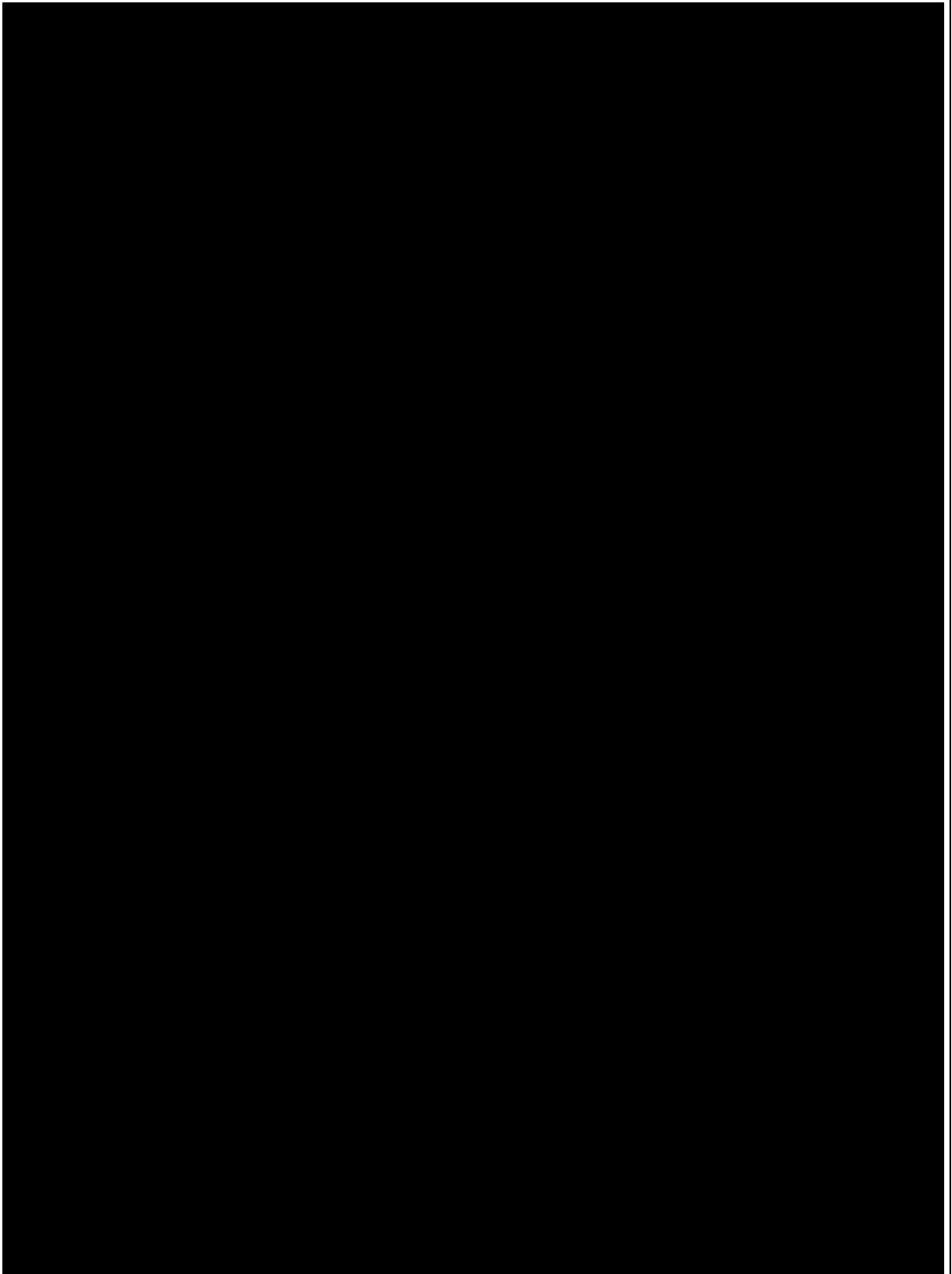

Transmission Owner Innovation Roll-Out Mechanism Submission Pro Forma

Section 6: Appendices continued

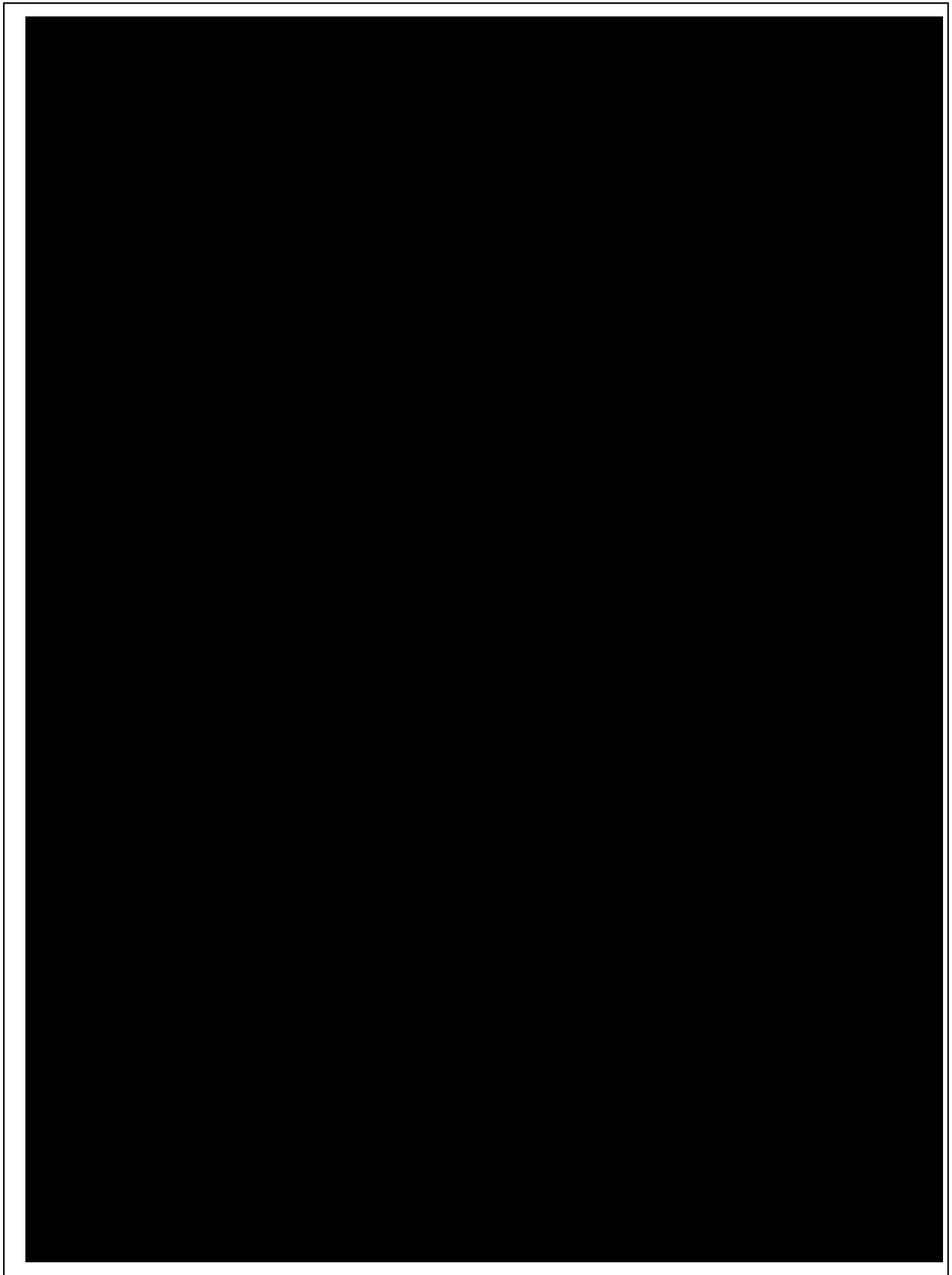

Transmission Owner Innovation Roll-Out Mechanism Submission Pro Forma

Section 6: Appendices continued

6.3 Appendix C: Overview of HTLS technology

11. HIGH TEMPERATURE, LOW SAG CONDUCTORS (HTLS)

Metallurgy and materials science have moved forward significantly in recent years allowing conductor manufacturers to develop new, highly specialised conductors for use on new and existing overhead lines.

Many of these new conductors incorporate cores manufactured from complex alloys which are extremely strong and designed to operate at high temperatures. This strength relies on the core having a low coefficient of thermal expansion (CTE) and the design is such that it allows the core to control the CTE of the conductor over most, if not all of the operating temperature range.

There are several types of High Temperature, Low Sag conductors commercially available from numerous manufactures and most have found markets around the world. There is, perhaps understandably, a broad variation in the material composition, construction techniques and claimed performance of these conductors, however, most are derivatives of the types listed below:

11.1 Aluminium Conductor Steel Supported (ACSS)

ACSS is a concentric lay stranded conductor consisting of a stranded steel core with outer layers of 1350-0 (fully annealed) aluminium wires. ACSS conductors can carry a significant increase in current compared to ACSR because they can operate continuously at up to 200° C. When the ACSS conductor is heated the aluminium wires elongate and their load is transferred to the steel core. This phenomenon allows the conductor to fully utilise the low coefficient of thermal expansion and low creep properties of its steel core. When the temperature is lowered, the aluminium wires are typically permanently elongated and do not return to their original length. ACSS conductor can also be compacted (ACSS/TW) where the use of trapezoidal shaped strands effectively reduces the overall diameter of the conductor for a given section area and thus reduces its wind loading on the tower.

11.2 Thermal Resistant Aluminium Conductor Steel Supported (TACSR) & (HiTACSR)

TACSR and HiTACSR conductors have wires of thermally resistant aluminium alloy over a core of stranded steel wires and can operate continuously at 150° C. Japan and Korea have used these conductors extensively for the transmission of additional power at high operating temperatures. One disadvantage of this conductor is that it has been limited to use on new build lines, as it has a sag equivalent to ACSR and additional clearance is required for the increased operating temperature.

11.3 Aluminium Conductor Invar Reinforced (ZTACIR) (or STACIR/Al in Korea)

ZTACIR is a development of TACSR conductor having a low coefficient of expansion 'Invar' steel core and extra thermal resistant aluminium alloy wires which can operate continuously at 210° C. When ZTACIR is at operating temperature the aluminium wires elongate and their load is transferred to the 'Invar' steel core. Therefore, the sag of ZTACIR at high temperature can be equal to the sag of ACSR at conventional operating temperature and TACSR at 150°C.

11.4 Aluminium Conductor Invar Reinforced (XTACIR)

XTACIR is a further development of ZTACIR conductor having a low coefficient of expansion 'Invar' steel core and special ultra thermal resistant aluminium alloy wires which can operate continuously at 230° C.

Transmission Owner Innovation Roll-Out Mechanism Submission Pro Forma

Section 6: Appendices continued

11.5 Gap conductor (GZTACSR)

GZTACSR conductor has a steel core of round, galvanized high tensile steel wires, surrounded by layers of trapezoidal shaped aluminium alloy strands. The inner layer forms a tube that encloses the steel core such that a gap exists between the core and the aluminium alloy strands. The tensile strength is taken by the steel core wires and, after heating, the aluminium strands move relatively to the steel core into their plastic state, thus the sag is determined by the coefficient of expansion of the steel core only. This conductor has a maximum continuous operating temperature of 170° C, with the capability of short-term operation up to 210° C.

11.6 Aluminium Conductor Composite Reinforced (ACCR)

Aluminium Conductor Composite Reinforced is a 2002 development by the 3M Company of USA. In this design the steel core is replaced by a core made of alumina fibres in an aluminium matrix with a very low coefficient of thermal expansion, resulting in a HTLS conductor with very small sags at elevated temperatures. Extra thermal resistant aluminium alloy wires can operate continuously at 210° C with the capability of short-term operation up to 240° C. The strength of this core is comparable to that of a steel core and the alumina fibres have a lower thermal expansion than aluminium or steel and can operate at high temperatures. The ampacity gains are, depending on type of existing conductor, estimated at 1.5 to 3.0 times that of an equivalent ACSR.

11.7 Aluminium Conductor Composite Core (ACCC and ACCC/TW)

The TransPowr™ Aluminium Conductor Composite Core Concentric-Lay-Stranded is a recent development by the CTC and General Cable Company of USA. It is similar to their design of ACSS/TW but the steel core is replaced by a high strength carbon and glass fibre reinforced polymer (composite) with a very low coefficient of thermal expansion, resulting in a HTLS conductor with very small sags at elevated temperatures. Outer layers are of 1350-0 (fully annealed) aluminium wires. The strength of core is comparable to that of a steel core with a lower thermal expansion than aluminium or steel and can operate at a temperature of 175°C with the capability of short-term operation up to 200°C. The core is rated as non-conductive.

Extract of conclusion:

When the replacement of existing twin 400mm² Zebra ACSR is being considered and there is a requirement for a slight increase in capacity then, given average costs, replacement with twin 425mm² Totara AAAC would be recommended.

Where system requirements are projected to exceed the capabilities of twin 425mm² Totara AAAC, then, given average costs, it is recommended that an ACCR conductor is considered to be a viable alternative to installing twin 500mm² Rubus AAAC.

It is recommended that SP proceed with a detailed technical evaluation of the ACCR conductor. This should include the design and financial benefits and should consider other networks where the system has been installed and energised at similar voltages to the SP Network.

Transmission Owner Innovation Roll-Out Mechanism Submission Pro Forma

Section 6: Appendices continued

6.4

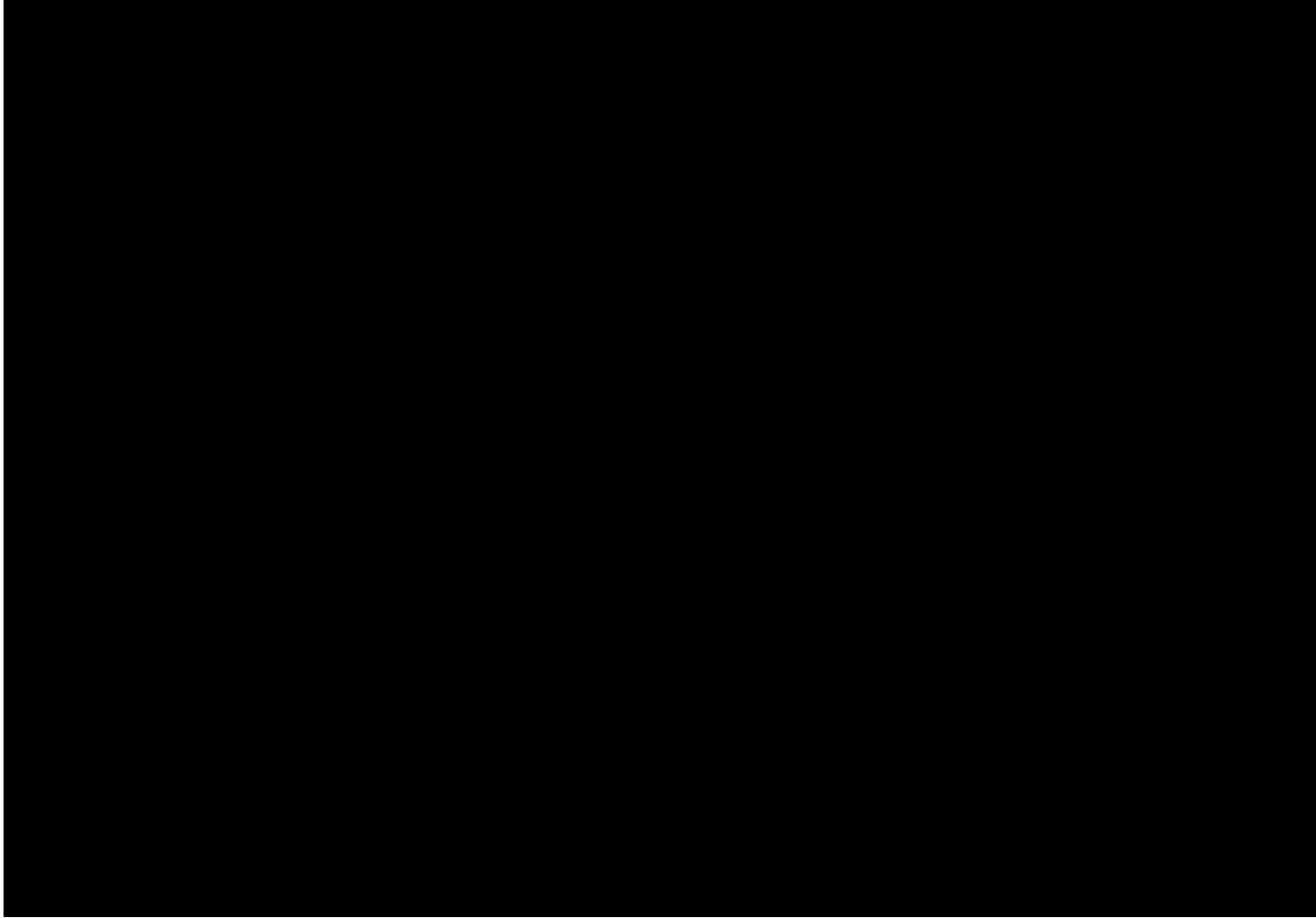

Transmission Owner Innovation Roll-Out Mechanism Submission Pro Forma

Section 6: Appendices continued



Transmission Owner Innovation Roll-Out Mechanism Submission Pro Forma

Section 6: Appendices continued

6.5 Appendix E: Summary on study to deliver YY Route with minimal outage

The outages required for the work introduce a commercially unacceptable loss of export for a seven month period of the works and SPT were asked to review the construction processes in order to obtain efficiencies during the delivery of the project. The report highlighted a number of efficiencies from the perspective of the Overhead Line Network Engineering Design Team by deploying ACCR in place of 'gap' GZTACSR:

- Elimination of the 'soaking' process would save a 24hr period at the end of every conductor pull in ever conductor pulling section - this equates to a three week saving over the project
- The reduction of jointing and the elimination suspension core clamping will save approximately 1 day in ever conductor pulling section – this equates to three weeks over the project.
- The installation of ACCR has removed the requirement to upgrade steel members and foundations as a result of reduced loading.

It is estimated that the outage programme for the reconductoring works could be reduced from seven (7) months to five (5) months immediately with the possibility of a further reduction as a result of the implication of the following recommendations. The contract programme for the main outage works should be presented in the 'Invitation to Tender' as five (5) months.

The revision in design conditions of the conductor system will alone reduce the outage programme by approximately four (4) to six (6) weeks. It is anticipated that further reductions can be found by carrying out further detail design works, engaging the services of key consultants and by a full consideration of the main contract strategy.

The ACCR conductor system has similar loads to the existing conductor system and it is envisaged that there will be no requirement to upgrade or replace any components. The 'in-service' performance of the route since it was commissioned is satisfactory and there are no verticality issues recorded during the feasibility studies. Any foundation found to be insufficient, due to ground condition or installation quality during the contract, can be upgraded out with any outage works.

ACCR Manufacturer 3M have stated that a support team is available for the design, installation and monitoring of their conductor system. By engaging them in advance and using the expertise gained from global installations of ACCR, 3M Engineers will be able to identify suitable winch positions and consider 'pull through' sections, where the length of a pulling section can be increased double and reduce the number of pulling positions.

Transmission Owner Innovation Roll-Out

Mechanism Submission Pro Forma

Section 6: Appendices continued

6.6 Appendix F: Training required for HTLS deployment

To ensure the correct procedures recommended by the manufacturer and specifically the method of jointing the Aluminium Matrix core are fully understood, four specific types of training have been identified which should be completed as recommended, in advance of the installation of the new ACCR Conductor system.

General Training

Training to familiarise stakeholders has been developed and delivered in a series of informal presentations from the conductor manufacturer.

Full System Installation Training

This type of training will be aimed at the key parties directly involved in the installation of the conductor system and for representatives of the relevant SPT Maintenance teams. This training will be developed in conjunction with 3M and will be jointly delivered by SPT and 3M. The hire of the National Grid Training Centre at Eakring, has been agreed this centre has been the main NGC overhead line training facility for over 20 years. This centre will provide a safe and accessible training facility with support from NGC and is not connected to any electrical system. The training will cover the following areas:

- Conductor component identification
- Jointing procedures
- Installation equipment preparation
- Conductor Installation
- Conductor Termination and 'Clamping-in'
- Maintenance Techniques
- Installation of mid-span joint
- Conductor Spacing
- Helical repair of damaged conductor

Key Component Competence Training

When the contractors have received their initial training it will be deemed their responsibility to carry out further competence repetitive training based on the installation of key components that are being installed and delegate personnel to take responsibility for the jointing procedures. This should be carried out on low-level training towers similar to the SPT tower at Dealain House. The use of Dealain should be considered if no other facility can be resourced.

Project and conductor system awareness

A general education presentation explain the new ACCR system, should be cascaded to parties indirectly involved with the installation contract or with the future operation and maintenance of the conductor system. This should be in the form of an informal presentation covering the basic design and development of the system and should provide suitable understanding of the new system, given the inevitable curiosity of a conductor system that can operate at 1900C (the maximum operating temperature National Grid has designated to the Curlew system).

Transmission Owner Innovation Roll-Out Mechanism Submission Pro Forma

Section 6: Appendices continued

6.7 Appendix G: National Grid HTLS IFI project update: Acoustic Emissions from

Annual IFI Report

nationalgrid

Project title	Acoustic Emissions from HV Overhead Conductors
Project Engineer	Richard Morris
Description of project	<p>The key objective of the proposed research is aimed at understanding the causes of excessive noise from overhead line (OHL) conductors and how this might be alleviated. The aims of the project are as follows:</p> <p>Characterise the surface ageing processes, including corrosion, on conductors including types known as GAP, AAAC and solid aluminium:</p> <ul style="list-style-type: none"> • The deposition of species (e.g. sea salt, dust, soot, pollutants, etc.) from the atmospheric environment onto the conductor surface and how these influence local processes such as pitting corrosion and hydrophobicity. • Determination of initial surface chemical state for the conductor, including hydrophobicity; how this chemistry changes as a function of environmental stresses, including: moisture, atmospheric deposition, high voltage, etc. • Determination of initial surface physical state for the conductor, this being predominantly surface roughness; the progression of roughness as a function of environmental stresses (i.e. as above). • Study interactions (if any) within the conductor, including effect of internal moisture, greasing and galvanic corrosion between steel core and aluminium conductor. • Identification of the key factors involved in physico-chemical deterioration of the surface and, hence, development of a model of surface damage with time. <p>Characterise the corona discharge activities resulting from wet high voltage surfaces:</p> <ul style="list-style-type: none"> • Audible discharge activity will be characterised in terms of volume and frequency content as a function of surface hydrophobicity, surface conductivity, surface roughness, and moisture conductivity. • The impact of the physical form of the substrate (conductor) will be determined, including conductor geometry strand size and shape and pitch. • The way in which moisture behaves macroscopically on a conductor will be determined including the impact of wind, inclination, geometry and hydrophobicity. • Measurements of force generated by discharges will also be determined. <p>Provide a model showing the causes of excessive corona discharge leading to noise and radio frequency interference (RFI) from 'gap' type conductors:</p> <ul style="list-style-type: none"> • The way in which complete spans of conductor might be excited to generate excessive corona discharge, noise and radio discharge from discharge activity will be modelled. • Electrodynamical behaviour resulting from the novel conductor structure will also be considered as a potential cause of the noise and radio discharge. • Generate at least one solution for to the problem of excessive corona discharge producing noise (considering requirements for existing and new installations). <p>Working with National Grid engineers, potential remedial solutions will be identified.</p> <p>Information will be supplied in a form suitable for inclusion in future National Grid specification to minimise future exposure.</p>

Transmission Owner Innovation Roll-Out Mechanism Submission Pro Forma

Section 6: Appendices continued

Annual IFI Report

nationalgrid

Expenditure for financial year	Internal £12k External £101k Total £113k	Expenditure in previous (IFI) financial years	Internal £27k External £703k Total £730k
Total project costs (collaborative + external + [company])	£843k	Projected 2013/14 costs for National Grid	£0k
Technological area and/or issue addressed by project	<p>The environmental impact of assets is a key concern to the public and National Grid. One key aspect of this is the audible noise produced by plant. Noise resulting from high voltage overhead lines is well studied, and models exist for traditional conductors and conductor bundles. However, recent experience of Matthew GAP conductor has demanded a rethink of the fundamental, largely empirical models used.</p> <p>This work will challenge existing models and create data on which to base new models suitable for application on any form of conductor. This will allow novel conductors to be deployed with a clear understanding of their acoustic and electromagnetic noise emission characteristics</p> <p>The corrosion characteristics of new conductor materials will allow improved asset management, and the implications of ageing on acoustic noise to be determined.</p> <p>Additional focus is now being directed towards developing a coating solution which can be applied retrospectively to single spans as part of a strategy to manage noise issues.</p>		
Type(s) of innovation involved	Incremental	Project Benefits Rating	Project Residual Risk
		7	3
Expected benefits of project	<p>National Grid has already spent £1.35M reconductoring just a few spans at one location on the ZO route, costs such as this could easily escalate should National Grid begin to receive more noise complaints from members of the public following reconductoring with Matthew Gap conductor. The avoidance of only one repeat event of this type would save £1.35m and more than repay the project costs as well as improving the noise issues.</p> <p>The avoidance of costs associated with conductor cleaning or inspection. The cleaning of conductor on only one span of the ZDA cost in the region of £25k for direct expenditure only, so future annual savings can be in the region of £12.5k per annum if one intervention can be avoided every two years, plus savings in outage planning and project management time.</p> <p>Avoidance of staff time taken up in managing complaints, both in liaising directly with complainants and local Environmental Health Officers, and undertaking monitoring visits.</p> <p>There are no clear mitigation measures available at present, so the avoidance of costs and extended time scales associated with having to resort to presently available alternatives, for example the use of triple instead of twin bundles, requiring the diverting of routes and/or rebuilding of towers, and the potential requirement to apply for Section 37 consents. The savings here can be considerable.</p> <p>Better specification for conductors on future schemes will reduce the need to respond reactively following complaints .</p>		

Full report: <http://www2.nationalgrid.com/WorkArea/DownloadAsset.aspx?id=19713>