

To:

- 1. Company Secretary
Thanet OFTO Limited
6th Floor
350 Euston Road
Regent's Place
London NW1 3AX
United Kingdom**

- 2. All interested parties**

NOTICE UNDER SECTION 8A(3) OF THE ELECTRICITY ACT 1989

The Gas and Electricity Markets Authority (the "Authority") hereby gives notice pursuant to section 8A(3) of the Electricity Act 1989 (the "Act") as follows:

1. An application for a transmission licence (the "Licence") to be granted under section 6(1)(b) of the Act has been received by the Authority from Transmission Capital Partners (the "Applicant") on behalf of Thanet OFTO Limited (company number: 07343534) (the "Potential Licensee").
2. The Applicant is taking part in the competitive tender being conducted by the Authority to determine a person to whom the Licence is to be granted in respect of the Thanet transmission system extending from:

The onshore substation (E 384776.01 N 5685448.50), to

the offshore substation platform (E 404223.87 N 5699385.62)

3. If the Applicant resolves to the Authority's satisfaction the matters specified in regulation 18(4) of the Electricity (Competitive Tenders for Offshore Transmission Licences) Regulations 2010 and if the Authority determines to grant the Licence to the Potential Licensee then the Authority proposes to modify standard conditions E12 (Not used) and E13 (System Operator – Transmission Owner Code) of the Licence.
4. The proposed modifications involve:

- (a) Standard condition E12: omitting standard condition E12 (Not Used) and adding to the Licence instead, amended standard conditions:

- E12 - A1 (Definitions and Interpretation)
- E12 - A2 (Market Rate Revenue Adjustment)
- E12 - A3 (Post Tender Revenue Adjustment)
- E12 - B1 (Transmission System Area)
- E12 - B2 (Activities Restrictions)
- E12 - C1 (Conduct of the Transmission Business)
- E12 - C2 (Separation and Independence of the Transmission Business)
- E12 - C3 (Restriction on use of certain information)
- E12 - C4 (Appointment of Compliance Officer)
- E12 - D1 (Offshore Regulatory Reporting)
- E12 - D2 (Equity Transaction Reporting Requirement)
- E12 - J1 (Restriction of Transmission Revenue: Definitions)
- E12 - J2 (Restriction of Transmission Revenue: Revenue from Transmission Owner Services)
- E12 - J3 (Restriction of Transmission Revenue: Allowed Pass-through Items)
- E12 - J4 (Restriction of Transmission Revenue: Annual Revenue Adjustments)
- E12 - J5 (Restriction of Transmission Charges: Adjustments)
- E12 - J6 (Provision of Information to the System Operator)
- E12 - J7 (Duration of the Revenue Restriction Provisions)
- E12 - J8 (Allowances in respect of Security Costs)
- E12 - J9 (Basis of Transmission Owner Charges)
- E12 - J10 (Excluded Services)
- E12 - J11 (The Network Innovation Competition);

- (b) Standard condition E13: adding two new paragraphs (paragraphs 5 and 6).

5. The effect of these modifications is to:

(a) add to the Licence the amended standard conditions E12 - A1 to E12 - J11, instead of standard condition E12; standard condition E12 being omitted from the Licence. In summary, the general effect of adding these amended standard conditions is:

- i. for amended standard condition E12 - A1, to set out relevant definitions and interpretations that relate to the proposed amended standard conditions;
- ii. for amended standard condition E12 - A2, to set out the process for adjusting the base transmission revenue of the Potential Licensee to account for the difference in market rates between those assumed in the tender revenue stream and those determined on the date of financial close;
- iii. for amended standard condition E12 - A3, to define the process for determining the post tender revenue adjustment;
- iv. for amended standard conditions E12 - B1 and E12 - B2, to set out the boundaries and location of the transmission system and the activities that the Potential Licensee is restricted from taking part in;
- v. for amended standard conditions E12 - C1 to E12 - C4, to set out provisions on business separation between the Potential Licensee and any associated business;
- vi. for amended standard condition E12 - D1, to set out the requirements on the Potential Licensee to provide information to the Authority for each relevant year;
- vii. for amended standard condition E12 - D2, to require the licensee to provide an annual submission to the Authority providing details of any relevant equity transactions;
- viii. for amended standard conditions E12 - J1 to E12 - J10, to define in standard condition E12 - J1, certain terms, expressions, words and phrases used in standard conditions E12 - J1 to E12 - J10 and to set out incentives and obligations on the Potential Licensee with regards to:
 1. revenue entitlement from transmission owner services (E12 - J2);
 2. allowed pass through items (E12 - J3);
 3. annual revenue adjustments (such as the transmission system availability incentive and incremental capacity incentive) (E12 - J4);
 4. reporting to the Authority in respect of regulated transmission revenue exceeding allowed transmission owner revenue (E12 - J5);

5. provision of information to the System Operator (E12 - J6);
 6. duration of the revenue restriction provisions (E12 - J7);
 7. allowances in respect of security costs (E12 - J8);
 8. basis of transmission owner charges (E12 - J9); and
 9. excluded services (E12 - J10);
- ix. for amended standard condition E12-J11 to establish arrangements known as the Network Innovation Competition (the "NIC") which will enable the Potential Licensee to compete for funding for eligible NIC projects; and
- (b) to add to standard condition E13 two new paragraphs (paragraphs 5 and 6), which set out that, if the Authority so directs, any reference to a "Special Condition" in the System Operator – Transmission Owner Code (the "STC") or the STC Framework Agreement shall be read as "Amended Standard Condition" in relation to this Licence.
- 6.** The reasons why the Authority proposes to make these modifications are set out in various documents published by or on behalf of the Authority including:
- (a) [Decision under Section 11A \(1\) \(b\) of the Electricity Act 1989 to modify offshore electricity transmission licenses so as to introduce Amended Standard Condition E12-D2: Equity Transaction Reporting Requirement](#), October 2014
 - (b) [Notice under Section 11A\(1\)\(a\) of the Electricity Act 1989 \(The Network Innovation Competition\)](#), January 2013;
 - (c) [Cover letter - version 0.7 of the draft generic Offshore Transmission Owner Licence](#), October 2010;
 - (d) [Consultation letter on version 0.6 of the draft generic Offshore Transmission Owner Licence](#), September 2010;
 - (e) [Offshore Electricity Transmission: Final Statement on the Competitive Tender Process](#), June 2009;
 - (f) [Overview of Great Britain's Offshore Electricity Transmission Regulatory Regime - joint DECC-Ofgem statement](#), June 2009; and
 - (g) [Offshore Electricity Transmission – A Joint Ofgem/DECC Regulatory Policy Update](#), November 2008.
- 7.** In summary, the reasons are, in relation to:
- (a) standard condition E12: to omit from the Licence that standard condition which is "Not Used" and instead to add to the Licence amended standard conditions E12 - A1 to E12 - J11 which provide for the revenue entitlement, performance incentives, business separation requirements, regulatory reporting and other requirements and obligations on the Potential Licensee; and
 - (b) standard condition E13: to ensure that, if a direction under paragraph 5 of standard condition E13 is issued, a reference to a special condition A1 to J11

in the STC or the STC Framework Agreement shall be read in relation to the Licence so as to be consistent with the relevant reference to any of amended standard conditions E12 - A1 to E12 - J11 of the Licence.

- 8.** The specific reasons for adding amended standard conditions E12 - A1 to E12 - J11 are to:
- (a) ensure that the Potential Licensee's role as a transmission owner is clearly defined by setting out in the Licence the boundaries and location of the transmission system and the activities that the Potential Licensee is restricted from taking part in (E12 - B1 and E12 - B2);
 - (b) ensure that no affiliated party of the Potential Licensee can obtain an unfair commercial advantage in other markets, by requiring the Potential Licensee to have in place the appropriate systems, processes and information restrictions. This is done by setting out the requirements for business separation between the Potential Licensee and any associated business (E12 - C1 to E12 - C4);
 - (c) protect the interests of consumers by enabling the Authority to monitor the revenue of the transmission business (including any under and over collection of revenue) by requiring the Potential Licensee to provide appropriate information to the Authority, thus allowing the Authority to monitor whether the correct revenues are being collected by the Potential Licensee (E12 - D1, E12- D2 and E12 - J5);
 - (d) secure that the Potential Licensee is able to finance its activities by providing for the Potential Licensee to be remunerated for:
 - i. providing transmission owner services, by setting out how it should calculate its revenue entitlement (E12 - J2, E12 - J3 and E12 - J4). The Tender Revenue Stream (the "TRS") stated in amended standard condition E12-J2 is based on the tender revenue stream bid by the Applicant Invitation to Tender (ITT) stage of the tender process, which has been updated to reflect further information available to the Applicant since the date of the ITT submission, including the draft final transfer value for the Project.
 - ii. providing excluded services (E12 - J9 and E12 - J10);
 - (e) ensure that the transmission assets are operated in a manner that contributes to security of supply and facilitates the transmission of renewable electricity, by incentivising the Potential Licensee to maximise the availability of the transmission assets (E12 - J4);
 - (f) protect the interests of consumers by ensuring that mechanisms are provided in the Licence to enable adjustments to be made to the revenue entitlement of the Potential Licensee for diverse matters including cost pass through items (E12 -J3), market rates changes (E12-A2) and for costs incurred by the Potential Licensee for providing transmission owner services during a security period following a direction issued by the Secretary of State under section 34(4) of the Act (E12 - J8);
 - (g) ensure the Potential Licensee provides relevant information to the System Operator so that the System Operator can collect the correct amount of revenue for the Potential Licensee through the Transmission Network Use of System charges (E12 - J6);

- (h) enable the Authority where requested by the Potential Licensee to remove part or all of the revenue restrictions that are applied to the Potential Licensee (E12 – J7);
 - (i) ensure that there is a statement approved by the Authority setting out the basis upon which the Potential Licensee will make transmission owner and excluded services charges (E12 – J9 and E12 – J10); and
 - (j) enable the Potential Licensee to take part in the Network Innovation Competition (E12 – J11).
- 9.** The Authority proposes to add a bespoke contingent event revenue adjustment mechanism (the “CEA mechanism”) to amended standard condition E12 – J3. The reasoning behind this decision is set out in the cover letter published alongside this notice. In summary:
- (a) The CEA mechanism is a bespoke cost pass through item which will allow for the Potential Licensee’s revenue to be adjusted should material costs and/or expenses arise as a result of the following specific contingent events:
 - i. the licensee incurring costs in connection with measures to achieve first compliance with Section K Paragraph 7.1 of the STC
 - ii. any liability of the licensee to repair or replace a subsea cable following an internal cable fault attributable to a ‘Root Cause’. The Root Cause is defined to be either the failure to earth the copper tubing surrounding the fibre optic cables during installation or the fact that the outer plastic sheath of the fibre optic cables is not uniformly semiconducting due to a defect in the manufacturing process. This contingent event will only be triggered when two conditions are satisfied. First, the Licensee has been unable to procure insurance without exclusion for either of the above issues at a normal market rate for any affected sections of the subsea cable. Second, the costs incurred, or expected to be incurred, exceed the sums available to the Licensee under the indemnity provided by the developer.
 - (b) The offshore regime incentivises licensees to manage costs efficiently over a 20 year period but also recognises that licensees may not be best placed to manage such risks where they are not sufficiently within their control. There are therefore a number of pre-defined revenue adjustment mechanisms in the licence that seek to optimally reallocate risk for a small number of known, but unpredictable, factors. The Authority considers that the most appropriate method for allowing provision for costs and/or expenses resulting from the contingent event in connection with this Project is by including a CEA mechanism in the licence.
- 10.** The Authority proposes to add additional limbs (e), (f) and (g) to paragraph 9 of amended standard condition E12-J4 which lists the circumstances under which a transmission service reduction on the transmission assets is not included in the calculation of the availability incentive. The reasoning behind this decision is set out in the cover letter published alongside this notice. In summary:
- (a) The inclusion of bespoke exclusion limbs will ensure that the Potential Licensee’s revenue is not adversely affected should transmission service reductions occur as a result of the following specific events within the relevant periods defined under paragraph 9 of amended standard condition E12-J4:

- i. measures undertaken for the licensee to achieve or resume compliance with Section K Paragraph 2.3 of the STC;
- ii. measures undertaken in connection with the licensee achieving first compliance with Section K Paragraph 7.1 of the STC as a result of compliance with Section D, Part 1, paragraph 2.2.6.1 of the STC; and
- iii. measures undertaken to rectify the crossing of the licensee's export cable's phases and/or to rectify inadequate joint and cable support and segregation at specified onshore joint bays.

(b) The inclusion of these bespoke exclusion limbs is consistent with the principle of protecting the Potential Licensee's revenue stream in certain circumstances from outages linked to works that take place post asset transfer.

(c) The exclusion described in paragraph 10(a)(iii) relates to the Developer's plans to undertake works on the specified onshore joint bays, which will require outages. There is a risk that these works may not be completed before asset transfer. However, if the Developer has successfully completed the required works before the licence is granted, the Authority proposes to omit exclusion limb (g) from paragraph 9 of amended standard condition E12-J4 on grant.

- 11.** In addition the Authority proposes to add a further limb (h) to paragraph 9 of amended standard condition E12-J4. The reasoning behind this decision is set out in the cover letter published alongside this notice. In summary limb (h) will exclude from the availability incentive any reduction in transmission system availability resulting principally from an internal cable fault attributable to a Root Cause, these being the same as defined for contingent event (ii) in paragraph 9 of this notice.
- 12.** Having considered all of the circumstances we have decided that it is appropriate and proportionate to include this bespoke exclusion limb to protect the Potential Licensee against revenue losses that may occur as a result of these project specific circumstances.
- 13.** The proposed modifications, which are set out in an annex to this notice, and documents referred to in this notice are available on the website (www.ofgem.gov.uk).
- 14.** Any representations or objections to the proposed modifications must be made in writing on or before 24/11/2014 to: Katie Taaffe, Office of Gas and Electricity Markets, 9 Millbank, London, SW1P 3GE or to offshorelicensing@ofgem.gov.uk

.....

**Min Zhu,
Associate Director, Offshore Transmission**

**Duly authorised on behalf of the
Gas and Electricity Markets Authority**

27th October 2014

ANNEX TO NOTICE UNDER SECTION 8A(3) OF THE ELECTRICITY ACT 1989

Amended Standard Condition E12 - A1: Definitions and Interpretation

1. In these conditions unless the context otherwise requires:

"asset transfer"	means the transfer to the licensee of transmission assets to which this licence relates as set out in Annex B to amended standard condition E12–B1 (Transmission System Area).
"associated business"	means an affiliate, related undertaking, or business unit of the transmission business or the ultimate controller of the transmission business.
"ex post assessment"	means the assessment of the economic and efficient costs which ought to have been incurred in connection with the development and construction of the licensee's transmission system undertaken by the Authority in accordance with the Electricity (Competitive Tenders for Offshore Transmission Licences) Regulations 2010.
"external transmission activities"	means any business of the licensee or any affiliate or related undertaking of the licensee comprising or ancillary to the maintenance, repair or operation in an emergency of any electricity distribution system or any part of the national electricity transmission system other than the licensee's transmission system.
"relevant year"	means a year beginning on 1 April of each calendar year and ending on 31 March of the following calendar year.
"relevant year t"	means that relevant year for the purposes of which any calculation falls to be made.
"relevant year t-1"	means the relevant year immediately preceding relevant year t and similar expressions shall be construed accordingly.

2. Subject to paragraph 1, unless the context otherwise requires, words and expressions used in the standard conditions of this licence shall bear the same meaning in amended standard conditions E12–A1 to E12–J11.

3. Where a term is used in amended standard conditions E12–A1 to E12–J11 and is also used in Section E of the standard conditions for electricity transmission licences then, unless the context otherwise requires, it shall have the same meaning in amended standard conditions E12–A1 to E12–J11 as is ascribed to that term in Section E of the standard conditions.
4. Any reference in amended standard conditions E12–A1 to E12–J11 to:
 - (a) a provision thereof;
 - (b) a provision of the standard conditions of electricity transmission licences;
 - (c) a provision of the standard conditions of electricity supply licences;
 - (d) a provision of the standard conditions of electricity distribution licences;
 - (e) a provision of the standard conditions of electricity generation licences;
 - (f) a provision of the standard conditions of electricity interconnector licences;shall, if these or the standard conditions in question come to be modified, be construed, so far as the context permits, as a reference to the corresponding provision of these or the standard conditions in question as modified.
5. Any reference in this licence to the provisions of the Companies Act 1985 shall be construed as including a reference to those provisions as amended, substituted, inserted or repealed by corresponding provisions of the Companies Act 2006, or a statutory instrument made under the Companies Act 2006.

Amended Standard Condition E12–A2: Market Rate Revenue Adjustment

1. The purpose of this condition is to establish the process for adjusting (whether upwards or downwards) the base transmission revenue (BR_t) (as defined in amended standard condition E12–J2 (Restriction of Transmission Revenue: Revenue from Transmission Owner Services)) of the licensee that is required as a consequence of the difference between:
 - (a) market rates assumed in the tender revenue stream (TRS_t) and determined for the post tender revenue adjustment ($PTRA_t$) (both as defined in amended standard condition E12 - J2 (Restriction of Transmission Revenue: Revenue from Transmission Owner Services)); and
 - (b) market rates determined on the date of the Authority’s direction pursuant to paragraph 6 of this condition.
2. For the purpose of paragraph 1(a) the market rates determined for the $PTRA_t$ shall be the market rates assumed in TRS_t .
3. The licensee shall use reasonable endeavours to have in place on the date this condition comes into force, an Authority approved market rate revenue adjustment methodology statement as is necessary to facilitate the achievement of the market rate revenue adjustment objectives set out in paragraph 4.
4. For the purpose of paragraph 3 of this condition, the market rate revenue adjustment objectives are:
 - (a) that compliance with the market rate revenue adjustment methodology ensures that the market rate revenue adjustment (MRA_t) shall only reflect changes in market rates;
 - (b) that compliance with the market rate revenue adjustment methodology ensures that the market rate revenue adjustment (MRA_t) shall take account of the difference between market rates described in paragraph 1(a) and paragraph 1(b); and
 - (c) that compliance with the market rate revenue adjustment methodology ensures that the market rate revenue adjustment (MRA_t) can be effected in a manner which is compatible with the financial close protocol.
5. For the purposes of paragraph 1, the market rate revenue adjustment (MRA_t) shall be calculated in accordance with the Authority approved market rate revenue adjustment methodology statement.
6. As soon as reasonably practicable after this licence comes into force (and in any event, no later than the date of asset transfer) the Authority may direct in writing the value of the market rate revenue adjustment (MRA_t), (as defined in paragraph 4 of amended standard condition E12 - J2 (Restriction of Transmission Revenue: Revenue from Transmission Owner Services)).
7. In this condition:

"financial close protocol" means the process and/or timescales agreed with the Authority to effect the funding for asset transfer.

"market rates"

means the following:

- (a) interest rates;
- (b) retail price index swap rates;
- (c) gilt rates;
- (d) index linked gilt rates; and
- (e) bond spreads.

Amended Standard Condition E12 - A3: Post Tender Revenue Adjustment

1. The purpose of this condition is to establish the process for adjusting (whether upwards or downwards) the base transmission revenue (BR_t) (as defined in amended standard condition E12 - J2 (Restriction of Transmission Revenue: Revenue from Transmission Owner Services)) of the licensee that is required as a consequence of the difference between:
 - (a) the Authority's estimate of the costs associated with developing and constructing the transmission system to which this licence relates; and
 - (b) the Authority's assessment, once the transmission system is available for use for the transmission of electricity, of the costs associated with developing and constructing the transmission system to which this licence relates.
2. For the purposes of paragraph 1, the value of the post tender revenue adjustment ($PTRA_t$) shall account for:
 - (a) the difference between:
 - (i) the Authority's estimate assumed in the tender revenue stream (TRS_t) as defined in amended standard condition E12–J2 (Restriction of Transmission Revenue: Revenue from Transmission Owner Services) of the costs associated with developing and constructing the transmission system to which this licence relates; and
 - (ii) the Authority's assessment, once the transmission system is available for use for the transmission of electricity, of the costs associated with developing and constructing the transmission system to which this licence relates
 - (b) the economic and efficient costs incurred by the licensee as a consequence of the difference between the estimate and assessment of the costs described in subparagraphs 2(a)(i) and (ii) above.
3. The licensee shall use reasonable endeavours to have in place on the date this condition comes into force, an Authority approved post tender revenue adjustment methodology statement as is necessary to facilitate the achievement of the post tender revenue adjustment objectives set out in paragraph 4.
4. For the purpose of paragraph 3 of this condition, the post tender revenue adjustment objectives are:
 - (a) that compliance with the post tender revenue adjustment methodology ensures that the post tender revenue adjustment ($PTRA_t$) shall take account of the difference between the Authority's estimate and the Authority's assessment described in subparagraphs 2(a) (i) and (ii); and
 - (b) that compliance with the post tender revenue adjustment methodology ensures that the post tender revenue adjustment ($PTRA_t$) can be effected in a manner which is compatible with the financial close protocol (as defined in amended standard condition E12 - A2 (Market Rate Revenue Adjustment)).
5. For the purposes of paragraph 1, the post tender revenue adjustment ($PTRA_t$) shall be calculated in accordance with the Authority approved post tender revenue adjustment methodology statement.
6. As soon as reasonably practicable after this licence comes into force (and in any event, no later than the date of asset transfer) the Authority may direct in writing the value of

the post tender revenue adjustment ($PTRA_t$) (as defined in paragraph 4 of amended standard condition E12 - J2 (Restriction of Transmission Revenue: Revenue from Transmission Owner Services)).

Amended Standard Condition E12 - B1: Transmission System Area

1. This licence is granted for the "Thanet transmission system" within the Specified Area (stated in Schedule 1 (Specified Area) of this licence) and more particularly defined in paragraph 2.
2. In this condition, the "Thanet transmission system" means the offshore transmission system extending from point A to point B (defined below) together with all associated cables, transformers, switchgear and connections, and all other plant or equipment making up or supporting the said transmission system with the benefit, subject to the applicable conditions therein, of all wayleaves and/or servitude rights relating thereto where:

A is the Onshore Substation (E 384776.01 N 5685448.50)

B is the Offshore Substation (E 404223.87 N 5699385.62)

In this condition, the transmission area is the geographic area set out in Annex A to this condition. The connection points of the transmission system are also defined by the circuit diagram in Annex B to this condition.

ANNEX A TO AMENDED STANDARD CONDITION E12 - B1 (TRANSMISSION SYSTEM AREA)

The transmission system area is the marked area set out below.

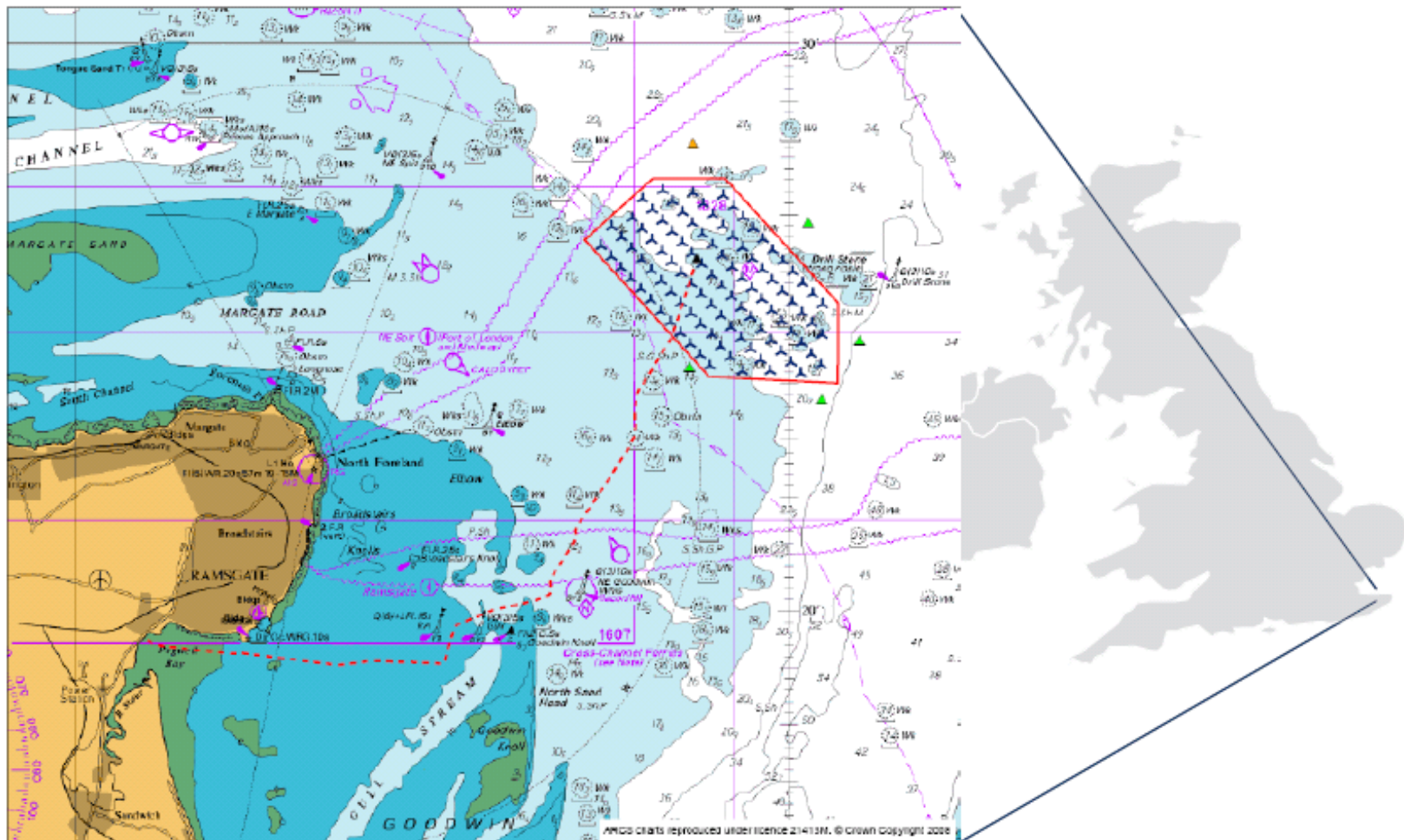

ANNEX B TO AMENDED STANDARD CONDITION E12 - B1 (TRANSMISSION SYSTEM CIRCUIT)

The transmission system is defined by the circuit diagram set out below.

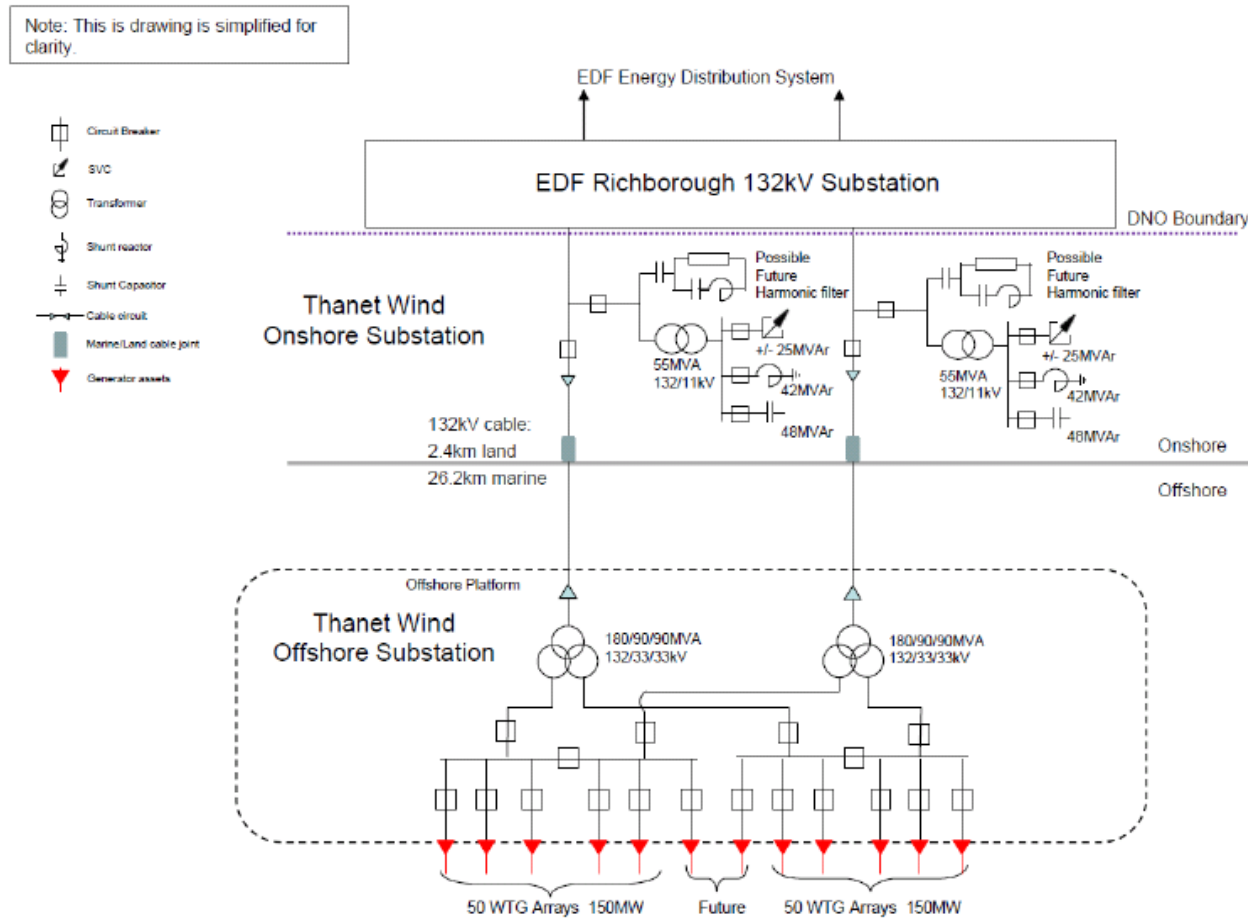

Amended Standard Condition E12 - B2: Activities Restrictions

1. Subject to the provisions of paragraph 2 below (made in accordance with section 7(2A)(a) of the Act), the licensee is authorised by paragraph 1 of Part I (Terms of the Licence) of this licence to participate in the transmission of electricity for the purpose of giving a supply to any premises or enabling a supply to be so given.
2. The licensee shall not:
 - (a) co-ordinate or direct the flow of electricity onto or over the whole or any part of the national electricity transmission system except where permitted to do so under the STC, subject to the approval of the Authority, or where required to do so by any other licence condition; and
 - (b) outside of the transmission system area, make available assets comprising part of the national electricity transmission system which are intended for the purpose of conveying or affecting the flow of electricity, except where the Authority has issued a direction to the licensee pursuant to standard condition E21 (Offshore Transmission Owner of Last Resort) insofar as it relates to the transmission system specified in that direction.

Amended Standard Condition E12 - C1: Conduct of the Transmission Business

1. The licensee shall conduct its transmission business in the manner best calculated to secure that, in complying with its obligations under this licence:
 - (a) the licensee;
 - (b) any affiliate or related undertaking of the licensee including, for the avoidance of doubt:
 - (i) any affiliate or related undertaking that intends to participate in a competitive tender exercise to be appointed as an offshore transmission owner; and
 - (ii) any affiliate or related undertaking participating in a competitive tender exercise to be appointed as an offshore transmission owner;that is a subsidiary of, or is controlled by the ultimate controller of, the licensee;
 - (c) any user of the national electricity transmission system; and
 - (d) any other transmission licensee;obtain no unfair commercial advantage including, in particular, any such advantage from a preferential or discriminatory arrangement, being, in the case of such an advantage accruing to the licensee, one in connection with a business other than its transmission business.
2. Except insofar as the Authority may direct, the licensee shall secure and procure separate premises, equipment, systems for recording and storing data, facilities, staff, and property from:
 - (a) those owned by a transmission licensee that, holds a co-ordination licence, and is responsible for co-ordinating and directing the flow of electricity onto or over the national electricity transmission system; and
 - (b) those owned by any associated business of the licensee that is authorised to generate, or supply electricity.

Amended Standard Condition E12 - C2: Separation and Independence of the Transmission Business

1. The licensee, in carrying out its licensed activities, shall put in place and at all times maintain such systems of control and other governance arrangements which are necessary to ensure that the licensee complies with the obligations contained in standard condition E6 (Prohibition of Cross-subsidies), standard condition E7 (Restriction on Activity and Financial Ring Fencing), and amended standard condition E12 - C1 (Conduct of the Transmission Business).
2. Unless otherwise directed by the Authority, the licensee shall by no later than 30 days after this condition comes into force have in place a statement ("the statement"), approved by the Authority, describing the practices, procedures and systems which the licensee has adopted (or intends to adopt) to secure compliance with paragraph 1 and in particular (but without prejudice to the generality of paragraph 1) ensure compliance with paragraph 4.
3. Where the Authority does not indicate otherwise within 60 days of receipt of the statement, the statement shall be deemed to be approved by the Authority.
4. The licensee shall:
 - (a) maintain appropriate managerial and operational independence of the licensee from any associated business in undertaking its activities under its licence;
 - (b) except insofar as the Authority consents to the licensee not doing so, ensure that:
 - (i) no business of the licensee (or of any affiliate or related undertaking of the licensee), other than the transmission business or any external transmission activities, may use or have access to:
 - (aa) premises or parts of premises occupied by persons engaged in, or engaged in respect of, the management or operation of the transmission business or any external transmission activities;
 - (bb) systems for the recording, processing or storage of data to which persons engaged in, or engaged in respect of, the management or operation of the transmission business or any external transmission activities also have access;
 - (cc) equipment, facilities or property employed for the management or operation of the transmission business or any external transmission activities; or
 - (dd) the services of persons who are (whether or not as their principal occupation) engaged in, or in respect of, the management or operation of the transmission business or any external transmission activities; and
 - (ii) it can and does, insofar as is legally possible, prevent any person who has ceased to be engaged in, or in respect of, the management or operation of the transmission business from being engaged in, or in respect of, the activities of any other business of the licensee (or of any affiliate or related undertaking of the licensee) until the expiry of an appropriate time from the date on which he ceased to be engaged by the transmission business.

5. The managerial and operational independence referred to in paragraph 4(a) above shall include the establishment of separate boards of directors for the transmission business and for any associated businesses.
6. Each member of such boards of directors or executives for associated businesses who is also a director of the offshore transmission business shall fulfil their role in relation to the taking of such decisions as if he or she were a director of a legally incorporated company whose sole business is the business in respect of which the board he or she is a member of has been established.
7. The licensee shall revise the statement prepared in accordance with paragraph 2 when circumstances change such that the statement prepared in accordance with paragraph 2 no longer secures compliance with paragraph 1 and such revision of the statement shall only become effective once the Authority has approved the revised statement in accordance with paragraph 2 or 3.
8. The licensee shall use its best endeavours to ensure compliance with the terms of the statement as from time to time revised and approved by the Authority.
9. The licensee shall publish a copy of the approved statement prepared in accordance with paragraph 2 (or the latest approved revision) on its company website within 7 days of its approval by the Authority.

Amended Standard Condition E12 - C3: Restriction on use of certain information

1. Any information relating to or deriving from the management or operation of the transmission business shall, for the purposes of this condition, be treated as confidential information.
2. The licensee shall not (and shall procure that its affiliates and related undertakings shall not) disclose or authorise access to confidential information:
 - (a) save to the extent provided by paragraph 3, to such of its (or its affiliates' or related undertakings') employees, agents, advisers, consultants or contractors as are engaged in, or in respect of, the management or operation of any other business (whether or not a separate business) of the licensee; or
 - (b) save to the extent permitted by paragraph 3, to any other person.
3. The licensee shall (and shall procure that its affiliates and related undertakings shall) disclose or authorise access to confidential information only:
 - (a) in the following circumstances, namely:
 - (i) to such of its (or its affiliates' or related undertakings') employees, agents, advisers, consultants or contractors as are engaged in, or in respect of, the management or operation of the transmission business or any external transmission activities and who require access to the information for that purpose;
 - (ii) to personnel of any holder of a transmission licence engaged in the external transmission activities of that transmission licence holder, to the extent necessary for the performance by such personnel of those external transmission activities, and the use by such personnel of that information for that purpose;

provided that effective arrangements are maintained in place at all times for ensuring that no further disclosure of any information supplied or obtained pursuant to this paragraph is made and that such information is used only for the purpose of the transmission business or any external transmission activities of the licensee;
 - (b) where the licensee (or any affiliate or related undertaking of the licensee) is required or permitted to disclose such information by virtue of:
 - (i) any requirement of a competent authority;
 - (ii) the standard conditions of any licence granted or taking effect as if granted under the Act or any document referred to in such a licence with which it is required by virtue of the Act or that licence to comply;
 - (iii) any other requirement of law; or
 - (iv) the rules of the Electricity Arbitration Association or of any judicial or other arbitral process or tribunal of competent jurisdiction;

- (c) where such information was provided by or relates to any person who has notified (or otherwise agreed with) the licensee that it need not be treated as confidential;
- (d) where such information, not being information provided by or relating to any person other than the licensee, is placed by the licensee in the public domain; or
- (e) where such information is required for the purposes of assisting the holder of a co-ordination licence, to prepare for and plan and develop the operation of the national electricity transmission system

and in each case the licensee shall disclose or authorise access to the confidential information only insofar as is necessary or appropriate in all the circumstances.

4. The licensee shall use all reasonable endeavours to ensure that any person who is in possession of or has access to confidential information in accordance with subparagraph 3(a) shall use such information only for the purposes of the transmission business or any external transmission activities.
5. In this condition:

"competent authority" means the Secretary of State, the Authority, the Compliance Officer, the Stock Exchange, the Panel on Take-overs and Mergers, or any local or national agency, regulatory body, authority, department, inspectorate, minister (including Scottish Ministers), ministry, official or public or statutory person (whether autonomous or not) of, or of the government of, the United Kingdom, the United States of America or the European Community.

"confidential information" means any information relating to or deriving from the management or operation of the transmission business.

"Electricity Arbitration Association" means the unincorporated members' club of that name formed inter alia to promote the efficient and economic operation of the procedure for the resolution of disputes within the electricity supply industry by means of arbitration or otherwise in accordance with its arbitration rules.

Amended Standard Condition E12 - C4: Appointment of Compliance Officer

1. The licensee shall, following consultation with the Authority, appoint a competent person (who shall be known as the "Compliance Officer") for the purpose of facilitating compliance by the licensee with this condition and with standard condition E6 (Prohibition of Cross-subsidies), standard condition E7 (Restriction on Activity and Financial Ring Fencing), amended standard condition E12 - C1 (Conduct of the Transmission Business) amended standard condition E12 - C2 (Separation and Independence of the Transmission Business) and amended standard condition E12 - C3 (Restriction on use of certain information) (the "relevant duties").
2. The licensee shall at all times engage the services of the Compliance Officer for the performance of such duties and tasks as the licensee considers it appropriate to assign to him for the purposes specified in paragraph 1, which duties and tasks shall include those set out in paragraph 7.
3. The licensee shall ensure that the Compliance Officer is not engaged in the management or operation of the licensee's transmission system or, except to the extent that the Authority agrees otherwise, the activities of any associated business.
4. The licensee shall establish a compliance committee (being a committee of the board of directors of the licensee) for the purpose of overseeing and ensuring the performance of the duties and tasks of the Compliance Officer set out in paragraph 7 and the compliance of the licensee with its relevant duties. Such a compliance committee shall report to the board of directors of the licensee and shall include among its members a director responsible for day-to-day compliance with the activities of this licence and such persons from within the licensee's business as are responsible for the management of regulatory issues relating to the licence.
5. The licensee shall procure that the Compliance Officer:
 - (a) is provided with such staff, premises, equipment, facilities and other resources; and
 - (b) has such access to its premises, systems, information and documentationas, in each case, he might reasonably expect to require for the fulfilment of the duties and tasks assigned to him.
6. The licensee shall make available to the Compliance Officer a copy of any complaint or representation received by it from any person in respect of a matter arising under or by virtue of the relevant duties.
7. The duties and tasks assigned to the Compliance Officer shall include:
 - (a) providing relevant advice and information to the licensee for the purpose of ensuring its compliance with the relevant duties;
 - (b) monitoring the effectiveness of the practices, procedures and systems adopted by the licensee in accordance with the statement referred to in amended standard condition E12 - C2 (Separation and Independence of the Transmission Business) and reporting thereon, this shall include, but not be limited to:
 - (i) ensuring the contracts of employment or engagement of relevant personnel shall include a statement on the importance of not disclosing information to other parties set out in paragraph 2 of amended standard condition E12 - C1 (Conduct of the Transmission Business). For this purpose a relevant member of staff or external person or consultant acting in such a role is anyone who are

aware of any information which could enable any unfair commercial advantage being obtained including, in particular, any such advantage from a preferential or discriminatory arrangement, being, in the case of such an advantage accruing to the licensee, one in connection with a business other than its transmission business;

- (ii) ensuring that each of the processes required under the Standard Conditions is monitored in respect of the effectiveness of its practices, procedures, systems and the supervision and sign off process relating to the release of information which could enable an unfair commercial advantage to be obtained by the parties set out in paragraph 2 of amended standard condition E12 - C1 (Conduct of the Transmission Business);
 - (c) advising whether, to the extent that the implementation of such practices, procedures and systems require the co-operation of any other person, they are designed so as to reasonably admit the required co-operation;
 - (d) investigating any complaint or representation made available to him in accordance with paragraph 6;
 - (e) recommending and advising upon the remedial action which any such investigation has demonstrated to be necessary or desirable;
 - (f) providing relevant advice and information to the licensee (including individual directors of the licensee) and the compliance committee established under paragraph 4 of this condition, for the purpose of ensuring its implementation of;
 - (i) the practices, procedures and systems adopted in accordance with the statement referred to at paragraph 2 of amended standard condition E12 - C2 (Separation and Independence of the Transmission Business); and
 - (ii) any remedial action recommended in accordance with sub-paragraph (e);
 - (g) reporting to the compliance committee any instances which come to his attention, relating to a member of any of the boards established under paragraph 5 of amended standard condition E12 - C2 (Separation and Independence of the Transmission Business), taking into account the interests of a business other than that in respect of which the board of which he is a member of has been established;
 - (h) reporting annually to the compliance committee established under paragraph 4 of this condition, in respect of each year after this condition comes into force, as to his activities during the period covered by the report, including the fulfilment of the other duties and tasks assigned to him by the licensee; and
 - (i) reporting annually to the board of directors of the licensee as to his activities during the period covered by the report, including the fulfilment of the other duties and tasks assigned to him by the licensee.
8. As soon as is reasonably practicable following each annual report of the compliance officer, the licensee shall produce a report in a form approved by the Authority:
- (a) as to its compliance during the relevant year with the relevant duties; and
 - (b) as to its implementation of the practices, procedures and systems adopted in accordance with the statement referred to at paragraph 2 of amended standard condition E12 - C2 (Separation and Independence of the Transmission Business).
9. The report produced in accordance with paragraph 8 shall in particular:

- (a) detail the activities of the Compliance Officer during the relevant year;
 - (b) refer to such other matters as are or may be appropriate in relation to the implementation of the practices, procedures and systems adopted in accordance with the statement at paragraph 2 of amended standard condition E12 - C2 (Separation and Independence of the Transmission Business); and
 - (c) set out the details of any investigations conducted by the compliance officer, including:
 - (i) the number, type and source of the complaints or representations on which such were based;
 - (ii) the outcome of such investigations; and
 - (iii) any remedial action taken by the licensee following such investigations;
 - (d) be accompanied by a certificate, approved by a resolution of the board of directors of the licensee and signed by a director pursuant to that resolution, on the degree to which the licensee has achieved compliance with its relevant duties and that the report of the compliance officer fairly presents the licensee's compliance with its relevant duties.
10. The licensee shall, as soon as reasonably practicable, submit to the Authority a copy of the report produced in accordance with paragraph 8 of this condition along with any supporting information and the licensee shall also publish a copy of the report on its website.

Amended Standard Condition E12 - D1: Offshore Regulatory Reporting

Part A: Application and Purpose

1. The purpose of this condition is to secure the collection of specified information, to an appropriate degree of accuracy by the licensee so as to enable the Authority to monitor effectively the revenue of the consolidated transmission business.

Part B: Offshore Regulatory Reporting - Regulatory Instructions and Guidance and Specified Information

2. For the purposes of this condition:

"offshore regulatory reporting – regulatory instructions and guidance" means the Offshore Transmission Owner Regulatory Instructions and Guidance available on the Ofgem website as modified from time to time under paragraph 12 and subject to paragraphs 13 to 17 shall include (without limitation):

- (a) the definition of specified information as detailed in the offshore regulatory reporting – regulatory instructions and guidance, to be collected pursuant to this condition which for the purposes of paragraph 7 is information relating to:
 - (i) all associated terms used in the derivation of the licensee's revenue entitlement as defined in the relevant section of amended standard conditions E12 – A1 to E12 – J10 of the licensee's transmission licence for purposes of paragraph 7(a) (Audited Revenue Return);
 - (ii) the allowed revenue term, the actual revenue term and income derived from excluded services as defined in the licensee's transmission licence for the purpose of paragraph 7 (b) (Forecast Revenue Return);
 - (iii) all associated cost terms to reconcile the costs of the licensee to its regulatory accounts for the purposes of the cost reporting pack referred to in paragraph 7(c);
 - (iv) the associated information and parameters used in the determination of the transmission system availability incentive as defined in amended standard condition E12 - J4 (Restriction of Transmission Revenue: Annual Revenue Adjustments) for the purposes of paragraph 7 (d); and
 - (v) the associated information and parameters used in the determination of the incremental capacity incentive as defined in amended standard condition E12 - J4 (Restriction of Transmission Revenue: Annual Revenue Adjustments) for the purposes of paragraph 7(e).
- (b) requirements for recording specified information which are reasonably necessary to enable an appropriate auditor to determine the accuracy and reliability of specified information;
- (c) requirements as to the form and manner in which specified information shall be provided to the Authority (including templates for doing so);
- (d) requirements as to the form and manner in which specified information shall be recorded and the standards of accuracy and reliability with which it shall be recorded; and
- (e) requirements as to the timing of the provision of specified information to the

Authority in respect of each relevant year.

3. The licensee shall:
 - (a) establish and maintain appropriate systems, processes and procedures to measure and record specified information in respect of the commencement relevant year and for each subsequent relevant year in accordance with the offshore regulatory reporting - regulatory instructions and guidance (including any associated information therein) for the time being in force pursuant to this condition;
 - (b) maintain all systems of control and other governance arrangements that ensure the information collected and reported to the Authority is in all material respects accurate and complete and is fairly presented and that all such systems of control and other governance arrangements are kept under regular review by the directors of the licensee with a view to ensuring that they remain effective for this purpose; and
 - (c) provide all such assistance as may be reasonably required to permit the Authority to review such systems from time to time.
4. The licensee shall notify the Authority immediately in the event that it discovers errors in the information or calculations used to derive the information submitted to the Authority under this licence condition.
5. The licensee shall collect the specified information required by the offshore regulatory reporting - regulatory instructions and guidance issued pursuant to this condition from the date on which such offshore regulatory reporting - regulatory instructions and guidance are issued by the Authority.

Part C: Information to be provided to the Authority

6. The licensee shall comply with the relevant provisions and information requirements of the offshore regulatory reporting - regulatory instructions and guidance issued pursuant to this condition.
7. From 1 April 2014, the licensee shall provide the Authority with:
 - (a) the information specified in the templates for the Audited Revenue Return contained in the offshore regulatory reporting - regulatory instructions and guidance by no later than 31 July following the end of the relevant year to which such information relates;
 - (b) the information specified in the templates for the cost reporting pack contained in the offshore regulatory reporting - regulatory instructions and guidance by no later than 31 July following the end of the relevant year to which such information relates;
 - (c) the information specified in the template for the transmission system availability incentive contained in the offshore regulatory reporting - regulatory instructions and guidance by no later than 31 July following the end of the relevant year to which the information relates;
 - (d) the information specified in the template for the incremental capacity adjustment contained in the offshore regulatory reporting - regulatory instructions and guidance by no later than 31 July following the end of the relevant year to which the information relates;
 - (e) where requested by the Authority the information specified in the template for the

Forecast Revenue Return contained in the offshore regulatory reporting - regulatory instructions and guidance, being the licensee's estimate of that information made on or before 1 April; and

- (f) other requirements as to the timing of the provision of the information specified in the templates from the offshore regulatory reporting – regulatory instructions and guidance in respect of each relevant year, at such regular periods as the Authority determines

Part D: Audit Requirements

8. The information referred to in sub-paragraphs 7(a) and 7(b) shall be accompanied by a report addressed to the Authority from the auditors, stating whether in their opinion:
 - (a) the information provided in accordance with sub-paragraphs 7(a) and 7(b) has been properly prepared in accordance with the offshore regulatory reporting - regulatory instructions and guidance; and
 - (b) the amounts presented are in accordance with the licensee's records which have been maintained in accordance with paragraph 3 of this condition.
9. The licensee shall require that any report from the auditors, referred to in paragraph 8, is accompanied by a letter from the auditors to the Authority detailing the procedures that the auditors have followed in reaching their opinion.
10. For the purposes of paragraph 8, the licensee shall at its own expense enter into a contract of appointment with the auditors, which includes a term requiring that the audit be conducted in accordance with all relevant auditing standards in force on the last day of the relevant year to which the audit relates as would be appropriate.
11. The licensee shall (and must procure, insofar as it is able to do so, that any affiliate or related undertaking of the licensee shall) co-operate fully with the auditors so as to enable them to complete and report to the Authority on any audit carried out in accordance with paragraph 8.

Part E: Modification to the Offshore Regulatory Reporting – Regulatory Instructions and Guidance

12. Where the Authority considers that the offshore regulatory reporting - regulatory instructions and guidance should be modified in such way as is necessary more effectively to achieve the purposes of this condition, the Authority may, subject to paragraphs 13 to 15, modify the offshore regulatory reporting - regulatory instructions and guidance by issuing a direction to all relevant transmission licensees.
13. Before issuing a direction under paragraph 12, the Authority, by notice given to all relevant transmission licensees, shall:
 - (a) state that it proposes to make a modification, and set out the date on which it proposes that this should take effect;
 - (b) set out the text of the modification, the purpose and effect of the modification, and the reasons for proposing it; and
 - (c) specify the time (not less than 30 days from the date of the notice) within which representations or objections with respect to the proposed modification may be made,

and consider any representations or objections which have been duly made and are not withdrawn, and give reasons for its decision.

14. Where any proposed modification of the offshore regulatory reporting - regulatory instructions and guidance relates to a requirement to provide specified information to a greater level of accuracy than was previously required, the Authority may only make such modification with the consent of each licensee to whom such modification relates, provided that such consent may not be unreasonably withheld or delayed by any relevant licensee.
15. Any modification of the offshore regulatory reporting - regulatory instructions and guidance under paragraph 12 to introduce an additional category of specified information or to enlarge an existing category of information shall not exceed what may reasonably be requested from the licensee by the Authority under paragraph 1 of standard condition E5 (Provision of Information to the Authority).
16. The provisions of the offshore regulatory reporting - regulatory instructions and guidance may not exceed what is necessary to achieve the purposes of this condition.
17. Nothing in this condition should require the licensee to produce any documents which it could not be compelled to produce or give evidence in civil proceedings before a court.

Amended Standard Condition E12-D2: Equity Transaction Reporting Requirement

Part A: Introduction

1. The purpose of this condition is to require the licensee to provide an annual submission to the Authority providing details of any relevant equity transactions.

Part B: Licensee's Obligations

2. Following the date of licence grant, the licensee shall prepare and submit to the Authority by 31 July 2016 and then by 31 July of each year following, details of any relevant equity transaction(s) that took place in the most recent relevant year except that the licensee may with the prior consent of the Authority not provide certain details of the relevant equity transaction where the Authority is satisfied that the licensee cannot provide such details.
3. Subject to paragraph 5, details to be prepared and submitted to the Authority for the purpose of paragraph 2 shall include:
 - (a) the date of the transaction(s);
 - (b) the value of the transaction(s);
 - (c) where applicable, the number of shares in the licensee transferred, issued or bought back and the percentage of the total shares of the licensee this represents; and
 - (d) where applicable, the percentage of the licensee now owned by the new ultimate controller(s).
4. The licensee's initial submission to the Authority under paragraph 2 should also include details of the quantity and value of equity invested in the licensee at the point of asset transfer.
5. Where a relevant equity transaction occurs as part of a transaction involving the issue, sale (or otherwise transfer) or buy back of shares in a company of which the licensee or a holding company of the licensee is a subsidiary, details of the value of the transaction provided to the Authority under paragraph 3 shall relate only to the value placed on the licensee for the purpose of that transaction.
6. Where licence grant falls between 1 January and 31 March of any year the reporting requirements specified in paragraph 2 will not be required on the first 31 July following licence grant. In such circumstances the information reporting requirements specified in paragraph 2 shall be prepared and submitted on the second 31 July following licence grant and must cover the period from licence grant to the end of the following relevant year (t=2).
7. For the purposes of this condition:

relevant equity transaction	means any transaction which: <ol style="list-style-type: none">(i) involves the issue, sale (or otherwise transfer) or buy back
-----------------------------	---

- (ii) of shares in the licensee; and/or results in a change in an ultimate controller of the licensee.

Amended Standard Condition E12 - J1: Restriction of Transmission Revenue:

Definitions

1. In this condition and in amended standard conditions E12 - J2 to E12-J10 inclusive:

"allowed pass-through items"	means the items referred to in paragraph 2 of amended standard condition E12 - J3 (Restriction of Transmission Revenue: Allowed Pass-through Items).
"allowed transmission owner revenue"	means in the commencement relevant year and every subsequent relevant year the revenue calculated in accordance with the formula set out in paragraph 4 of amended standard condition E12 - J2 (Restriction of Transmission Revenue: Revenue from Transmission Owner Services).
"average specified rate"	means the average of the daily base rates of Barclays Bank plc (or any other bank as the Authority may from time to time direct) during the period in respect of which the calculation falls to be made.
"base transmission revenue"	means the revenue calculated in accordance with the formula set out in paragraph 4 of amended standard condition E12 - J2 (Restriction of Transmission Revenue: Revenue from Transmission Owner Services).
"charge restriction conditions"	means any condition (including, without limitation, any revenue restriction condition) of this licence which places a monetary limitation on the revenue which may be recovered by the licensee during a given period;
"closing relevant year"	means the relevant year, commencing 1 April 2034, being no earlier than 20 years after the commencement relevant year.
"commencement relevant year"	means the relevant year, commencing 1 April 2014, in which this condition comes into force. In this relevant year $t=1$.

"Crown Estate Lease"	means any lease, licence, or agreement between the Licensee and the Crown Estate relating to the use of Crown Estate property to enable the transmission of electricity over the licensee's transmission system.
"event"	means any unscheduled or unplanned occurrence on, or relating to, a Transmission System including, without limitation, faults, incidents, breakdowns and adverse weather conditions.
"excluded services"	means those services provided by the licensee as part of its transmission business which in accordance with the principles set out in paragraph 1 of amended standard condition E12 - J10 (Excluded Services), are to be treated as excluded services.
"exceptional event"	means an Event or circumstance that is beyond the reasonable control of the licensee and which results in or causes a Transmission Service Reduction and includes (without limitation) an act of God, an act of the public enemy, war declared or undeclared, threat of war, terrorist act, blockade, revolution, riot, insurrection, civil commotion, public demonstration, sabotage, act of vandalism, fire (not related to weather), governmental restraint, Act of Parliament, other legislation, bye law or directive (not being any order, regulation or direction under section 32, 33, 34 and 35 of the Act) or decision of a Court of competent authority or the European Commission or any other body having jurisdiction over the activities of the licensee provided that lack of funds shall not be interpreted as a cause beyond the reasonable control of the licensee. For the avoidance of doubt, weather conditions which are reasonably expected to occur at the location of the event or circumstance are not considered to be beyond the reasonable control of the licensee.

"incentive period y"	means the twelve month period commencing 1 January of relevant year t-2 and ending 31 December of relevant year t-1.
"income adjusting event"	has the meaning set out in paragraph 15 of amended standard condition E12-J3 (Restriction of Transmission Revenue: Allowed Pass-through Items)
"metered"	means in relation to any quantity of units of electricity transmitted, as measured by a meter installed for such purpose or (where no such meter is installed) as otherwise reasonably calculated.
"network rates"	means: <ul style="list-style-type: none"> (a) in England and Wales, the rates payable by the licensee in respect of hereditaments on the Central Rating Lists (England and Wales) compiled under section 52 of the Local Government Finance Act 1988 and hereditaments on the Local Rating Lists compiled under sections 41 and 41A of the Local Government Finance Act 1988; and (b) in Scotland, the rates payable by the licensee in respect of any land and heritages on the Valuation Rolls compiled under the Local Government Scotland Act 1975, the Local Government etc (Scotland) Act 1994, or any legislation amending or replacing those enactments
"network rates revaluation"	means the exercise undertaken, typically at five yearly intervals, to reset the network rates payable by the licensee.
"outage"	means a planned temporary reduction in the extent to which transmission services are provided by a Transmission Owner.

"regulated transmission revenue"	means the revenue (measured on an accruals basis) derived from the provision of transmission owner services (including to any separate business, other than the transmission business) in the relevant year, after deduction of value added tax (if any) and any other taxes based directly on the amounts so derived.
"services reduction"	means the licensee's transmission services are not, other than by reason of an Outage, physically capable of being provided or are not capable, for immediate safety reasons or pursuant to environmental obligations, of being provided.
"tender relevant year"	means the relevant year in which the date that the tender exercise to which the grant of this licence relates was concluded, falls.
"transmission owner services"	means all services provided as part of the transmission business other than excluded services.
"transmission service reduction"	means a reduction in transmission services from the parameters and levels set out in the Services Capability Specification (in accordance with the STC) as a result of an outage or services reduction.
"unit"	means a kilowatt hour.

Amended Standard Condition E12 - J2: Restriction of Transmission Revenue: Revenue from Transmission Owner Services

1. The purpose of this condition is to establish the revenue restriction that determines the allowed transmission owner revenue that the licensee may earn from its transmission owner services in any relevant year.
2. The revenue entitlement of the licensee, determined in accordance with paragraph 4 below, shall commence upon the date this condition comes into force.
3. The licensee shall take all appropriate steps within its power to ensure that in any relevant year t , regulated transmission revenue shall not exceed the allowed transmission owner revenue calculated in accordance with the formula given in paragraph 4 below.

Formula for Allowed Transmission Owner Revenue (OFTO_t)

4. For the purposes of this condition, allowed transmission owner revenue (OFTO_t) shall take the value of zero in all relevant years preceding the commencement relevant year t and thereafter allowed transmission owner revenue (OFTO_t) shall be calculated in accordance with the following formula:

$$OFTO_t = BR_t + PT_t + PA_t - K_t \quad (1)$$

where:

OFTO_t means allowed transmission owner revenue in the relevant year t .

BR_t means base transmission revenue which shall be calculated as:

$$BR_t = ATR_t \times PR_t \times RIT_t \quad (2)$$

where:

ATR_t means the adjusted tender revenue which shall be calculated as:

$$ATR_t = TRS_t + MRA_t + PTR A_t \quad (3)$$

where:

TRS_t means the tender revenue stream and shall take the value of £16,874,000 in tender relevant year prices;

MRA_t means the market rate revenue adjustment and shall take the value set out in any direction issued pursuant to amended standard condition E12 - A2 (Market Rate Revenue Adjustment), otherwise it shall take the value zero;

PTRA_t means the post tender revenue adjustment and shall take the value set out in any direction issued pursuant to amended standard condition E12 - A3 (Post Tender Revenue Adjustment), otherwise it shall take the value zero;

PR_t means the proportion of revenue term representing the proportion of ATR_t to be recoverable in that relevant year and shall take the value 1, except:

- (a) in respect of the period before asset transfer in the commencement relevant year where it shall take the value zero
- (b) in respect of the period on or after asset transfer in the commencement relevant year where it shall take the value determined by the following formula:

$$PR_1 = 1 - \left(\frac{\text{No of days from date of asset transfer to start of commencement relevant year}}{365.25} \right) \quad (4)$$

- (c) in respect of the closing relevant year where it shall take the value determined by the following formula:

$$PR_{21} = \left(\frac{\text{No of days from date of asset transfer to start of commencement relevant year}}{365.25} \right) \quad (5)$$

- (d) in all relevant years subsequent to the closing relevant year, where it shall take the value zero.

RIT_t is the revenue indexation adjustment term for the relevant year t, and shall be derived from the following formula:

$$RIT_t = (1 + RPI_t) \times RIT_{t-1} \quad (6)$$

where:

RPI_t means the percentage change (whether of a positive or a negative value), expressed as a decimal number, in the arithmetic average of the Retail Price Index numbers published or determined with respect to each of the twelve months from January to December (both inclusive) in relevant year t-2 and the arithmetic average of the Retail Price Index numbers published or determined with respect to the same months in relevant year t-1; except:

in the tender relevant year, RIT_t shall take the value 1.

PT_t means the pass through revenue adjustment term, whether of a positive or of a negative value, made in the relevant year t in respect of allowed pass through items as derived in accordance with amended standard condition E12 - J3 (Restriction of Transmission Revenue: Allowed Pass-through Items);

PA_t means the performance availability revenue adjustment term, whether of a positive or of a negative value, made in the relevant year t in respect of annual revenue adjustments as derived in accordance with amended standard condition E12 - J4 (Restriction of Transmission Revenue: Annual Revenue Adjustments);

K_t means the revenue restriction correction factor, which is the difference between the regulated transmission revenue (AR_{t-1}) and the allowed transmission revenue ($OFTO_{t-1}$) in the previous year, whether of a positive or of a negative value, which takes the value zero in the first relevant year ($t=1$). In subsequent years, it is calculated in accordance with the formula below:

$$K_t = (AR_{t-1} - OFTO_{t-1}) \times \left[1 + \frac{(I_t + PI_t)}{100} \right] \quad (7)$$

where:

AR_{t-1} means the regulated transmission revenue in respect of the relevant year $t-1$.

$OFTO_{t-1}$ means the allowed transmission owner revenue in the relevant year $t-1$.

I_t means the average specified rate (as defined under those words in amended standard condition E12 - J1 (Restriction of Transmission Revenue: Definitions)) in the relevant year t .

PI_t means the penalty interest rate in relevant year t , which is equal to:

(a) where:

$$AR_{t-1} > 1.04 \times OFTO_{t-1} \quad (8)$$

the penalty interest rate shall be 4; and

(b) otherwise, it shall take the value zero.

Amended Standard Condition E12 - J3: Restriction of transmission revenue: Allowed Pass-through Items

1. The purpose of this condition is to provide for revenue adjustments to reflect certain costs that can be passed through to consumers as part of allowed transmission owner revenue.
2. For the purposes of paragraph 4 of amended standard condition E12 - J2 (Restriction of transmission revenue: revenue from transmission owner services) PT_t is derived from the following formula:

$$PT_t = LF_t + RB_t + CEL_t + DC_t + IAT_t + TPD_t + TCA_t + MCA_t + CEA_t \quad (9)$$

where

LF_t means the licence fee cost adjustment term, whether of a positive or of a negative value, and shall be determined in accordance with paragraph 3.

RB_t means the network rates cost adjustment term, whether of a positive or of a negative value, and shall be determined in accordance with paragraphs 4 and 5.

CEL_t means the Crown Estate Lease cost adjustment term, whether of a positive or negative value, and shall be determined in accordance with paragraph 6.

DC_t means the decommissioning cost adjustment term and shall be determined in accordance with paragraphs 7 to 13.

IAT_t means the income adjusting event revenue adjustment term, whether of a positive or of a negative value, and shall be determined in accordance with paragraphs 14 to 24.

TPD_t means the temporary physical disconnection payment term and shall be determined in accordance with paragraph 25.

TCA_t means the tender fee cost adjustment term and shall be determined in accordance with paragraph 26.

MCA_t means the Marine and Coastal Access Act 2009 cost adjustment term and shall be determined in accordance with paragraphs 27 to 33.

CEA_t means the contingent event1 revenue adjustment term and shall be determined in accordance with paragraphs 34 to 44.

Formula for the Licence Fee Cost Adjustment (LF_t)

3. For the purposes of paragraph 2, LF_t is an amount in respect of licence fee payments and means the amount equal to the payments made by the licensee, in the relevant year t , in accordance with its obligations set out in standard condition A4 (Payments to the Authority);

Formula for the Network Rates Cost Adjustment (RB_t)

4. For the purposes of paragraph 2, RB_t is an amount in respect of networks rates
-

payments and means, subject to paragraph 5 of this condition, the amount equal to the rates payments made by the licensee in the relevant year t.

5. The licensee shall at the time of network rates revaluation use reasonable endeavours to minimise the costs that it will incur in respect of network rates.

Formula for the Crown Estate Lease Cost Adjustment (CEL_t)

6. For the purposes of paragraph 2, CEL_t is an amount equal to the payments made by the licensee to the Crown Estate, in the relevant year t, in accordance with its obligations set out in its Crown Estate Lease in respect of the:

- (e) annual rent of the seabed; and
- (f) legal expenses of the Crown Estate for the preparation, negotiation and completion of the Crown Estate Lease.

Formula for the Decommissioning Cost Adjustment (DC_t)

7. Where the licensee considers, and can provide supporting evidence, that there will be additional costs and/or expenses in relation to the licensee's obligations with respect to decommissioning of the transmission system that has arisen due to a change in legislative requirements, then the licensee shall give written notice of this change to the Authority.
8. A notice provided to the Authority under paragraph 7 shall give particulars of:
 - (a) the change in legislative requirements to which the notice relates and the reason(s) why the licensee considers that it will face additional costs or expenses in complying with those obligations, and demonstrate that such costs and expenses are not included within the allowed transmission owner income;
 - (b) the expected amount of any change in costs and/or expenses that can be demonstrated by the licensee to be caused by the change in decommissioning requirements and how the amount of these costs and/or expenses has been calculated;
 - (c) the proposed amount of any allowed revenue adjustment proposed as a consequence of the change in decommissioning requirements and how this allowed revenue adjustment has been calculated; and
 - (d) any other analysis or information, which the licensee considers sufficient to enable the Authority to fully assess the change in legislative requirements to which the notice relates.
9. If the Authority considers that the analysis or information provided in sub-paragraphs 8(a) to 8(d) above is insufficient to enable the Authority to assess whether a change in decommissioning requirements has occurred and/or the amount of any allowed income adjustment that might be approved, the Authority can request that the supporting evidence be supplemented with additional information that it considers appropriate. If the Authority requests that the supporting evidence be supplemented with additional information, the licensee shall provide such information to the Authority within not more than one month of the Authority requesting such information.
10. A notice referred to in paragraph 7 shall be given as soon as is reasonably practicable after the occurrence of the change in requirements, and, in any event, not later than three months after the end of the relevant year in which it occurs.

11. The Authority shall determine:
 - (a) whether any or all of the costs and/or expenses given in a notice pursuant to paragraph 7 were caused by the change in legislative requirements;
 - (b) if so, whether the amount of the proposed income adjustment ensures that the financial position and performance of the licensee are, insofar as is reasonably practicable, the same as if that change in legislative decommissioning requirements had not taken place, and if not, what allowed income adjustment would secure that effect; and
 - (c) the periods, if any, over which the amounts should apply.
12. In relation to the relevant year t , the decommissioning cost adjustment term (DC_t) shall be:
 - (a) the value determined by the Authority under paragraph 11 above; or
 - (b) if the Authority has not requested additional information under paragraph 9 and the Authority has not made a determination under paragraph 11 above within three months of the date on which notice given by the licensee was provided to the Authority, the amount of the allowed income adjustment proposed by the licensee in that notice given to the Authority; or
 - (c) if the Authority requests additional information under paragraph 9 and the Authority has not made a determination under paragraph 11 above within three months after receiving the additional information requested, the amount of the allowed income adjustment proposed by the licensee in the notice given to the Authority; or
 - (d) in all other cases the value zero, including situations where the Authority has not made a determination under paragraph 11 above within three months of the date on which notice given by the licensee provided to the Authority, or within three months of the date on which the Authority received additional information if requested under paragraph 9, and the Authority has, before the end of the appropriate three month period, informed the licensee that the Authority considers that the analysis or information provided in accordance with paragraphs 8 and/or 9 is insufficient to enable the Authority to assess whether additional costs or expenses have occurred and/or the amount of any allowed income adjustment.
13. The Authority's decision in relation to any notice given under paragraph 7 shall be in writing, shall be copied to the licensee and shall be in the public domain.

Formula for the Income Adjusting Event Revenue Adjustment (IAT_t)

14. Where the licensee considers, and can provide supporting evidence that, in respect of relevant year t , there have been costs and/or expenses that have been incurred or saved by an income adjusting event, then the licensee shall give written notice of this event to the Authority.
15. An income adjusting event in relevant year t may arise from any of the following:
 - (a) an event or circumstance constituting force majeure under the STC;
 - (b) an event or circumstance resulting from an amendment to the STC not allowed for when allowed transmission owner revenues of the licensee were determined for the relevant year t ; and

- (c) an event or circumstance other than listed above which, in the opinion of the Authority, is an income adjusting event and is approved by it as such in accordance with paragraph 21 of this licence condition,

where the event or circumstance has, for relevant year t, increased or decreased costs and/ or expenses by more than £1,000,000 (the "STC threshold amount").

16. A notice provided to the Authority under paragraph 14 shall give particulars of:
 - (a) the event to which the notice relates and the reason(s) why the licensee considers this event to be an income adjusting event;
 - (b) the amount of any change in costs and/or expenses that can be demonstrated by the licensee to have been caused or saved by the event and how the amount of these costs and/or expenses has been calculated;
 - (c) the amount of any allowed income adjustment proposed as a consequence of that event and how this allowed income adjustment has been calculated; and
 - (d) any other analysis or information, which the licensee considers sufficient to enable the Authority and the relevant parties to fully assess the event to which the notice relates.
17. If the Authority considers that the analysis or information provided in sub-paragraphs 16(a) to 16 (d) (inclusive) above is insufficient to enable both the Authority and the relevant parties to assess whether an income adjusting event has occurred and/or the amount of any allowed income adjustment that should be approved, the Authority can request that the supporting evidence be supplemented with additional information that it considers appropriate. If the Authority requests that the supporting evidence be supplemented with additional information, the licensee shall provide such information to the Authority within not more than one month of the Authority requesting such information.
18. A notice of an income adjusting event shall be given as soon as is reasonably practicable after the occurrence of the income adjusting event, and, in any event, not later than three months after the end of the relevant year in which it occurs.
19. The Authority will make public, excluding any confidential information, any notice of an income adjusting event following its receipt.
20. Any notice submitted to the Authority under paragraph 14 above should clearly identify whether any of the information contained in the notice is of a confidential nature. The Authority shall make the final determination as to confidentiality having regard to:
 - (a) the need to exclude from disclosure, so far as is reasonably practicable, information whose disclosure the Authority considers would or might seriously prejudicially affect the interests of a person to which it relates; and
 - (b) the extent to which the disclosure of the information mentioned in sub-paragraph 20(a) is necessary for the purposes of enabling the relevant parties to fully assess the event to which the notice relates.
21. The Authority shall determine (after consultation with the licensee and such other persons as it considers desirable):
 - (a) whether any or all of the costs and/or expenses given in a notice pursuant to paragraph 14 were caused or saved by an income adjusting event;

- (b) whether the event or circumstance has increased or decreased the costs and/or expenses given in the notice pursuant to paragraph 14 by more than the STC threshold amount;
 - (c) if so, whether the amount of the proposed income adjustment ensures that the financial position and performance of the licensee are, insofar as is reasonably practicable, the same as if that income adjusting event had not taken place, and if not, what allowed income adjustment would secure that effect; and
 - (d) the periods, if any, over which the amounts should apply.
22. In relation to the relevant year t , the allowed income adjustment (IAT _{t}) shall be:
- (a) the value determined by the Authority under paragraph 21 above; or
 - (b) if the Authority has not requested additional information under paragraph 17 and the Authority has not made a determination under paragraph 21 above within three months of the date on which notice of an income adjusting event was provided to the Authority, the amount of the allowed income adjustment proposed as a consequence of the event in the notice given to the Authority under paragraph 14; or
 - (c) if the Authority requests additional information under paragraph 17 and the Authority has not made a determination under paragraph 21 above within three months after receiving the additional information requested, the amount of the allowed income adjustment proposed by the licensee in the notice given to the Authority; or
 - (d) in all other cases the value zero, including situations where the Authority has not made a determination under paragraph 21 above within three months of the date on which notice of an income adjusting event, provided under paragraph 14, was provided to the Authority, or within three months of the date on which the Authority received additional information if requested under paragraph 17, and the Authority has, before the end of the appropriate three month period, informed the licensee that the Authority considers that the analysis or information provided in accordance with paragraphs 16 and/or 17 is insufficient to enable the Authority to assess whether an income adjusting event has occurred and/or the amount of any allowed income adjustment.
23. The Authority's decision in relation to any notice given under paragraph 14 shall be in writing, shall be copied to the licensee and shall be in the public domain.
24. The Authority may revoke an approval of an income adjusting event and allowed income adjustment with the consent of the licensee, following consultation with the licensee and relevant parties, and any such revocation of any income adjusting event and allowed income adjustment shall be in writing, shall be copied to the licensee and shall be in the public domain.

Formula for the Temporary Physical Disconnection Payment (TPD _{t})

25. For the purposes of paragraph 2, TPD _{t} shall be an amount equal to the interruption payments made by the System Operator in the licensee's transmission system area and charged by the System Operator to the transmission licensee in accordance with the STC within each respective relevant year. Such costs shall include any financing or other costs such as to ensure that the financial position and performance of the licensee is, insofar as is reasonably practicable, the same as if those costs had not been incurred.

Formula for the Tender Fee Cost Adjustment (TCA_t)

26. For the purposes of paragraph 2, TCA_t shall be an amount representing the payments made to the Authority in accordance with The Electricity (Competitive Tender for Offshore Transmission Licences) Regulations 2010 with respect to the to the recovery of the Authority's tender costs. Where the payments have been made in relation to an application for the grant of more than one licence, the licensee shall attribute an appropriate proportion of the relevant payment made to the Authority.

Formula for the Marine and Coastal Act 2009 Cost Adjustment (MCA_t)

27. Where the licensee considers, and can provide supporting evidence, that there will be additional costs and/or expenses in relation to additional obligations imposed on the licensee with respect to the introduction of the Marine and Coastal Access Act 2009 requirements then the licensee may give written notice of these changes to the Authority.
28. A notice provided to the Authority under paragraph 27 shall give particulars of:
- (a) the additional obligations to which the notice relates and the reason(s) why the licensee considers that it will face additional costs or expenses in complying with those additional obligations, and demonstrate that such costs or expenses are not included within allowed transmission owner income;
 - (b) the expected amount of any change in costs and/or expenses that can be demonstrated by the licensee to be caused by the introduction of those new obligations under the Marine and Coastal Access Act 2009 and how the amount of these costs and/or expenses has been calculated;
 - (c) the proposed amount of any allowed revenue adjustment proposed as a consequence of the licensee incurring additional obligations in relation to the Marine and Coastal Access Act 2009 requirements and how this allowed revenue adjustment has been calculated; and
 - (d) any other analysis or information, which the licensee considers sufficient to enable the Authority to fully assess the additional obligations to which the notice relates.
29. If the Authority considers that the analysis or information provided in sub-paragraphs 28(a) to (d) above is insufficient to enable the Authority to assess the amount of any allowed income adjustment that might be approved, the Authority can request that the supporting evidence be supplemented with any additional information that it considers appropriate. If the Authority requests that the supporting evidence be supplemented with additional information, the licensee shall provide such information to the Authority within not more than one month of the Authority requesting such information.
30. A notice referred to in paragraph 27 shall be given as soon as is reasonably practicable after the new obligations imposed by the Marine and Coastal Access Act 2009 take effect, and, in any event, not later than three months after the end of the relevant year in which they occur.
31. The Authority shall determine:
- (a) whether any or all of the costs and/or expenses given in a notice pursuant to paragraph 27 were caused by the introduction of new obligations as a consequence of the Marine and Coastal Access Act 2009 requirements and not already incorporated within allowed transmission owner revenue;

- (b) if so, whether the amount of the proposed income adjustment ensures that the financial position and performance of the licensee are, insofar as is reasonably practicable, the same as if that the additional obligations had not been implemented, and if not, what allowed income adjustment would secure that effect; and
 - (c) the periods, if any, over which the amounts should apply.
32. In relation to the relevant year t , the Marine and Coastal Act 2009 Cost Adjustment (MCA_t) shall be:
- (a) the value determined by the Authority under paragraph 31 above; or
 - (b) if the Authority has not requested additional information under paragraph 29 and the Authority has not made a determination under paragraph 31 above within three months of the date on which notice given by the licensee was provided to the Authority, the amount of the allowed income adjustment proposed by the licensee in that notice given to the Authority; or
 - (c) if the Authority requests additional information under paragraph 29 and the Authority has not made a determination under paragraph 31 above within three months after receiving the additional information requested, the amount of the allowed income adjustment proposed by the licensee in the notice given to the Authority; or
 - (d) in all other cases the value zero, including situations where the Authority has not made a determination under paragraph 31 above within three months of the date on which notice given by the licensee provided to the Authority, or within three months of the date on which the Authority received additional information if requested under paragraph 29, and the Authority has, before the end of the appropriate three month period, informed the licensee that the Authority considers that the analysis or information provided in accordance with paragraphs 28 and/or 29 is insufficient to enable the Authority to assess whether additional costs or expenses has occurred and/or the amount of any allowed income adjustment.
33. The Authority's decision in relation to any notice given under paragraph 27 shall be in writing, shall be copied to the licensee and shall be in the public domain.

Formula for a revenue adjustment in respect of a Contingent Event Revenue Adjustment Term (CEA_t)

34. Where the licensee considers, and can provide supporting evidence, that there have been costs and/or expenses that have been or will be incurred by the licensee under or in respect of any contingent event, then the licensee shall give written notice of the contingent event to the Authority (in respect of which, the licensee shall not also be entitled to serve a notice in respect of such costs and/or expenses under paragraph 15 of this amended standard condition).
35. A notice provided to the Authority under paragraph 34 shall give particulars of:
- (a) the relevant contingent event to which the notice relates;
 - (b) the extent to which, if at all, the licensee has claimed or intends to claim for any costs and/or expenses arising out of or relating to the relevant contingent event under other routes of recourse, including but not limited to commercial solutions available to it, including any warranties and/or indemnities;

- (c) the amount of any change in costs and/or expenses that can be demonstrated by the licensee to have been or that will be incurred or suffered in connection with the relevant contingent event and how the amount of these costs and/or expenses has been calculated;
 - (d) the amount of any allowed revenue adjustment proposed as a consequence of the relevant contingent event, whether this allowed revenue adjustment is required for a one-off cost or for ongoing costs and how this allowed revenue adjustment has been calculated;
 - (e) where the contingent event is related to a Root Cause, evidence of all claims that the licensee has made or intends to make under the Cable Indemnity Agreement, including the particulars of all the costs and/or expenses incurred which have been, or will be, paid using the sums available to the licensee under the Cable Indemnity Agreement; and
 - (f) any other analysis or information, which the licensee considers sufficient to enable the Authority and the relevant parties to fully assess the relevant contingent event to which the notice relates.
36. If the Authority considers that the analysis or information provided in sub-paragraphs 35(a) to 35(f) (inclusive) above is insufficient to enable both the Authority and the relevant parties to assess the relevant contingent event and/or the amount of any allowed revenue adjustment that should be approved, the Authority can request that the supporting evidence be supplemented with additional information that it considers appropriate. If the Authority requests that the supporting evidence be supplemented with additional information, the licensee shall provide such information to the Authority within not more than one month of the Authority requesting the information, or within the period otherwise directed by the Authority.
37. A notice of a contingent event shall be provided as soon as is reasonably practicable after the occurrence of the relevant contingent event, and, in any event, not later than three months after the end of the relevant year in which it occurs.
38. The Authority will make public, excluding any confidential information, any notice of a contingent event following its receipt.
39. Any notice provided to the Authority under paragraph 34 should clearly identify whether any of the information contained in the notice is of a confidential nature. The Authority shall make the final determination as to confidentiality having regard to:
- (a) the need to exclude from disclosure, so far as is reasonably practicable, information whose disclosure the Authority considers would or might seriously prejudicially affect the interests of a person to which it relates; and
 - (b) the extent to which the disclosure of the information mentioned in sub-paragraph 39(a) is necessary for the purposes of enabling the relevant parties to fully assess the event or circumstance to which the notice relates.
40. The allowed revenue adjustment (CEAt) for each relevant year t shall be:
- (a) the value determined by the Authority where the Authority determines that a contingent event has occurred (after consultation with the licensee and such other persons as it considers desirable) in accordance with the following provisions:
 - a. the total amount of allowed revenue adjustment(s) over each relevant

year t will allow the licensee to recover costs and/or expenses provided in a notice pursuant to paragraph 34 that:

- i. were caused by the relevant contingent event;
 - ii. were, or are expected to be, incurred economically and efficiently;
 - iii. are net of all costs and/or expenses the licensee has claimed, or intends to claim, under other routes of recourse that the licensee has or ought to have available to it, including, but not limited to, warranties and indemnities.
 - b. the distribution of the total amount of allowed revenue adjustment(s) over relevant years shall take due account of the impact of any such distribution on the licensee (including consideration of the licensee's financial position as a result of any such distribution) and other relevant parties, and shall ensure that the licensee's financial position is, insofar as is reasonably practicable, the same as if all allowed costs and/or expenses were recovered within the year(s) when the costs were incurred or are expected to be incurred; or
 - (b) the value zero where the Authority determines that a contingent event has not occurred (after consultation with the licensee and such other persons as it considers desirable); or
 - (c) the value proposed by the licensee in the notice provided to the Authority under paragraph 34 where the Authority has not requested additional information under paragraph 36 and the Authority has not made a determination under sub-paragraph (a) or (b) of paragraph 40 within three months, or such other period that the Authority notifies to the licensee, of the date on which notice of a contingent event was provided to the Authority; or
 - (d) the value proposed by the licensee in the notice provided to the Authority under paragraph 34 where the Authority requests additional information under paragraph 36 and the Authority has not made a determination under sub-paragraph (a) or (b) of paragraph 40 within three months, or such other period that the Authority notifies to the licensee, after receiving the additional information requested; or
 - (e) the value zero in situations where the licensee fails to provide, within the relevant time period, additional analysis or information requested by the Authority under paragraph 36; or
 - (f) the value zero in situations where the Authority has requested additional analysis or information under paragraph 36, but where the Authority determines any information provided by the licensee is insufficient to enable the Authority to assess the relevant contingent event and/or the amount of any allowed revenue adjustment. In such circumstances the Authority shall provide written notice to the licensee prior to issuing any direction, and shall allow a period of no less than 14 days for the licensee to make any representations or objections.
41. The allowed revenue adjustment in relation to any notice provided under paragraph 34, set in accordance with paragraph 40, shall be in writing, shall be copied to the

licensee and shall be in the public domain.

42. The Authority may revoke an approval of a contingent event and allowed revenue adjustment with the consent of the licensee, following consultation with the licensee and relevant parties, and any such revocation of any contingent event and allowed revenue adjustment shall be in writing, shall be copied to the licensee and shall be in the public domain.
43. Where the Authority directs a revenue adjustment under paragraph 40 and all costs and/or expenses have not been incurred in full, the Authority may retrospectively vary the allowed revenue adjustment following full assessment of costs and/or expenses incurred and whether these were economic and efficient. Any such change to the allowed revenue adjustment shall be in writing and shall follow consultation with the licensee and other and such other persons as the Authority considers desirable.
44. In this condition:

“Cable Indemnity Agreement” means the agreement providing for indemnity arrangements in relation to the subsea cables dated on or about the date that this licence comes into force between Thanet Offshore Wind Farm and the licensee

“contingent event” means either:

a) any liability of the licensee to repair or replace all or part of the licensee’s subsea cables resulting principally from an internal cable fault attributable to a Root Cause where:

(1) the costs and/or expenses incurred or expected to be incurred in connection with the necessary repair or replacement exceed the sums available to the licensee under the Cable Indemnity Agreement; and

(2 a) the licensee has been unable to obtain insurance without exclusion for such a Root Cause on a subsea cable or part thereof on which a fault occurred; or

(2 b) such insurance has been obtained but the deductible is in excess of the Specified Deductible.

or

b) the licensee incurring costs in connection with measures to achieve first compliance with Section K Paragraph 7.1 of the STC as a result of compliance with Section D, Part 1, paragraph 2.2.6.1 of the STC.

“Root Cause”

means either or both of

- a) the failure, during installation of the subsea cables, to earth the copper tubing surrounding the fibre optic cables at the offshore substation prior to the date this licence comes into force;
or
- b) the fact that the outer plastic sheath of the fibre optic cables is not uniformly semiconducting due to a defect in the manufacturing process

“Specified Deductible”

Has the meaning defined under the Cable Indemnity Agreement

Amended Standard Condition E12 - J4: Restriction of Transmission Revenue: Annual Revenue Adjustments

1. The purpose of this condition is to provide for adjustments to allowed transmission revenue in relation to the licensee's transmission system performance and this condition shall not take effect until the transmission system to which this licence relates has been transferred to the licensee.
2. For the purposes of paragraph 4 of amended standard condition E12 - J2 (Restriction of Transmission Revenue: Revenue from Transmission Owner Services), PA_t is derived from the following formula:

$$PA_t = TSAI_t + TSAP_t + ICA_t \quad (10)$$

where:

$TSAI_t$ means the transmission system availability incentive, whether of a positive or of a negative value, as derived from the formula set out in paragraph 6;

$TSAP_t$ means the transmission system availability payment for the value of performance credits from the last 5 years of the revenue period, as determined in accordance with paragraph 21; and

ICA_t means the incremental capacity incentive adjustment term as derived from the formula set out in paragraph 22.

Part A: Transmission system availability incentive

3. The licensee shall, in providing transmission owner services, use reasonable endeavours to make its transmission system available to the System Operator in accordance with standard condition E15 (Obligation to provide transmission services) and Good Industry Practice to minimise the effect and duration of any transmission service reduction.
4. Where a transmission service reduction applies to a part of the licensee's transmission system and the licensee reasonably expects that the duration of such a transmission service reduction will apply for a period of more than 21 days then the licensee shall within 7 days of the transmission service reduction occurring notify the Authority in writing of the transmission service reduction including:
 - (a) details of the transmission service reduction on the transmission services the licensee provides to the System Operator;
 - (b) the cause of the transmission service reduction and whether, in the licensee's opinion, the transmission service reduction has been caused (in whole or in part) by an exceptional event;
 - (c) any interim work or other actions which are being undertaken to minimise the effect of the transmission service reduction; and
 - (d) indicate the timescale in which the licensee reasonably considers that the transmission service reduction will be resolved together with supporting information that shall include (without limitation) any Service Restoration Proposal agreed with the System Operator in accordance with the STC.
5. Where, in the incentive period y , the total effect and duration of all transmission service reductions, excluding those caused (in whole or in part) by an exceptional event:

- (a) results in transmission system availability being, on average, below 75 per cent in that incentive period; or
- (b) results in transmission system availability being, on average, below 80 per cent when considering the 24 month period of the incentive period y and the incentive period y-1;

then the licensee shall provide a written statement to the Authority, from an authorised director of the licensee, within three months of the end of incentive period y, explaining how the steps the licensee has taken have discharged the obligations in paragraph 3.

6. For the purposes of paragraph 2, the term $TSAl_t$ is derived from the following formula:

$$TSAl_t = \left(\frac{BR_{t-1}}{PR_{t-1}} \times TSAC_y \times PR_{t-6} \right) - BR_{t-1} \times TSAF_y \quad (11)$$

where $t=y$

where:

BR_t means base revenue calculated in accordance with the formula specified in paragraph 4 of amended standard condition E12 – J2 (Restriction of Transmission Revenue: Revenue from Transmission Owner Services); and

$TSAC_y$ means the transmission system availability credit factor, which in any relevant year before the commencement relevant year shall take the value zero and in each subsequent relevant year is the percentage credit revenue adjustment factor based on the licensee’s performance against the transmission system availability incentive during incentive period y, and is derived from the following formula:

$$TSAC_y = TSIF \times \left(\frac{PAPC_y}{AVCOL_{y-5}} \right) \quad (12)$$

where:

$TSIF$ means the transmission system incentive factor and shall in each incentive period y take the value of 10 per cent.

$PAPC_y$ means the performance availability payout credits, after being held in the performance balance for 5 incentive periods and offsetting any penalties in that period, available to be cashed in incentive period y as set out in paragraph 8.

$AVCOL_y$ means the annual value of the collar and is derived from the following formula:

$$AVCOL_y = \sum_{i=1}^{i=12} MVCOL_{i,y} \quad (13)$$

where:

$MVCOL_{i,y}$ means the monthly value of the collar and is derived from the following formula:

$$MVCOL_{i,y} = MTSA_i \times COL \quad (14)$$

where:

COL means the maximum penalty collar for the availability incentive of 4 per cent.

MTSA_i means the maximum transmission system availability in month i that is required to be delivered being the minimum of:

- (i) the aggregate Transmission Entry Capacity; and
- (ii) the maximum system availability in month i that is capable of being delivered by the licensee by providing transmission services to the Normal Capability Limits;

both expressed as number of MW hours that could be achieved if the available capacity were fully utilised.

TSAF_y means the transmission system availability penalty factor, which in any relevant year before the commencement relevant year shall take the value zero and in each subsequent relevant year is the percentage penalty revenue adjustment factor based on the licensee's performance against the transmission system availability incentive during incentive period y and, subject to paragraphs 14 to 16, is derived from the following formula:

$$TSAF_y = TSIF \times \left(\frac{-PPRO_y}{AVCOL_y} \right) \quad (15)$$

where:

PPRO_y means the performance penalty revenue offset representing the number of penalty permits that are offset against revenues in incentive period y as set out in paragraph 7.

7. For the purposes of paragraph 6, the performance penalty revenue offset (PPRO_y) shall be calculated in accordance with the following formula:

If $TPAPE_y < 0$ then (16)

If $TPAPE_y < -AVCOL_y$ then

$$PPRO_y = -AVCOL_y$$

If $TPAPE_y \geq -AVCOL_y$ then

$$PPRO_y = TPAPE_y$$

If $TPAPE_y \geq 0$ then

$$PPRO_y = 0$$

where:

$TPAPE_y$ means the total performance availability permits earned representing the cumulative value of penalties and credits earned up to and including incentive period y along with those credits and penalties up to period y that have effected revenue, being calculated as follows:

$$TPAPE_y = TPAPE_{y-1} + TSPP_y + TSPC_y - 5YPL_y - PPRO_{y-1} - PAPC_{y-1} \quad (17)$$

where:

$TSPP_y$ means the transmission system performance penalties incurred in each month i of incentive period y , being calculated as follows:

$$TSPP_y = \sum_{i=1}^{i=12} APE_{i,y} \quad (18)$$

where:

$APE_{i,y}$ means the availability penalties earned in each month i of incentive period y being calculated as follows:

$$\text{If } APAPE_{i,y} < 0 \text{ then} \quad (19)$$

$$APE_{i,y} = APAPE_{i,y}$$

$$\text{If } APAPE_{i,y} \geq 0 \text{ then}$$

$$APE_{i,y} = 0$$

$APAPE_{i,y}$ means the adjusted performance availability permits earned in each month i of incentive period y , being calculated as follows:

$$APAPE_{i,y} = (RSIP_{i,y} - (TSIT_i \times MTSA_i)) \times TSIR_i \quad (20)$$

where:

$TSIT_i$ means the base transmission system incentive target, in percentage terms, for month i as set out in Annex A.

$RSIP_{i,y}$ means the reported system incentive performance (expressed as the number of MW hours the system was capable of delivering) in respect of month i in incentive period y derived in accordance with paragraph 9 to 13.

$TSIR_i$ means the transmission system incentive rate as set out against the table in Annex A to this condition.

$TSPC_y$ means the transmission system performance credits earned in each month i of incentive period y , being calculated as follows:

$$TSPC_y = \sum_{i=1}^{i=12} ACE_{i,y} \quad (21)$$

where:

$ACE_{i,y}$ means the availability credits earned in each month i of incentive period y being calculated as follows:

$$\text{If } APAPE_{i,y} > 0 \text{ then} \quad (22)$$

$$ACE_{i,y} = APAPE_{i,y}$$

$$\text{If } APAPE_{i,y} \leq 0 \text{ then}$$

$$ACE_{i,y} = 0$$

$5YPL_y$ means the 5 year penalty limit, which limits the effect of large outages to only 5 years of OFTO revenue, taking the value zero until incentive period $y=6$ and is then calculated as follows:

$$\text{If } TSPP_{y-5} + AVCOL_{y-5} < 0 \text{ and if } 5YPB_y < 0 \text{ then} \quad (23)$$

$$5YPL_y = 5YPB_y$$

$$\text{If } TSPP_{y-5} + AVCOL_{y-5} \geq 0 \text{ or } 5YPB_y \geq 0 \text{ then}$$

$$5YPL_y = 0$$

where:

$5YPB_y$ means the 5 year penalty balance being calculated as follows:

$$5YPB_y = 5YPB_{y-1} + TSPP_{y-5} + TSPC_{y-1} - PPRO_{y-1} - 5YPL_{y-1} - PAC_{y-1} \quad (24)$$

8. For the purposes of paragraph 6 the performance availability payout credits ($PAPC_y$), represent those credits to effect revenue after being held in the performance balance (through the $5YCM_y$ mechanism) for 5 years from the incentive period y and offsetting any penalties in the intervening period, is determined in accordance with the following formula:

$$\text{If } 5YCM_y > 0 \text{ then} \quad (25)$$

$$PAPC_y = 5YCM_y$$

$$\text{If } 5YCM_y \leq 0 \text{ then}$$

$$PAPC_y = 0$$

where:

$5YCM_y$ means the 5 year credit mechanism, which holds all credits in the performance balance for 5 years, using them to offset any penalties in the intervening period before those credits can be cashed, and is calculated as:

$$5YCM_y = 5YCM_{y-1} + TSPC_{y-5} + TSPP_y - PPRO_{y-1} - 5YPL_{y-1} - PAC_{y-1} \quad (26)$$

9. For the purposes of this amended standard condition “reported system incentive performance ($RSIP_{i,y}$)” shall mean, in month i of incentive period y , the extent to which the licensee made transmission services available to the System Operator for the purposes of conveying, or affecting the flow of, electricity and reported system

incentive performance ($RSIP_{i,t}$) shall be calculated as the maximum transmission system availability in month i ($MTSA_i$) less the effect, also in month i , of any transmission service reduction that applied to licensee's transmission system, subject to the following exclusions:

- (a) any reduction in transmission system availability resulting from a de-energisation or disconnection of a user's equipment under an event of default as defined in the CUSC;
- (b) any reduction in transmission system availability resulting from a user's request for disconnection in accordance with the Grid Code;
- (c) any reduction in transmission system availability resulting from emergency de-energisation by a user as defined in the CUSC;
- (d) any reduction in transmission system availability resulting from an emergency de-energisation or disconnection of a user's equipment necessary to ensure compliance with the Electricity Safety, Quality and Continuity Regulations 2002, as amended from time to time, or to otherwise ensure public safety;
- (e) any reduction in transmission system availability during the Relevant Period, subject to the licensee ensuring compliance with Paragraph 3, solely as a result of measures undertaken for the licensee to achieve or resume compliance with Section K Paragraph 2.3 of the STC. For the purpose of this paragraph, the Relevant Period is either five years from the date this licence comes into force or until the licensee has achieved a period of 6 months continuous compliance with Section K Paragraph 2.3 of the STC, whichever is the shorter. For the avoidance of doubt, the relevant period shall end where, following the achievement or resumption of compliance with Section K Paragraph 2.3 of the STC and prior to the achievement of 6 months continuous compliance, any fault or negligence of the licensee results in a breach of compliance with Section K Paragraph 2.3 of the STC.
And
- (f) any reduction in transmission system availability during the Relevant Period, subject to the licensee ensuring compliance with Paragraph 3, solely as a result of measures undertaken in connection with the licensee achieving first compliance with Section K Paragraph 7.1 of the STC as a result of compliance with Section D, Part 1, paragraph 2.2.6.1 of the STC. For the purpose of this paragraph, the Relevant Period is four years from the date this licence comes into force or until the licensee achieves first compliance with Section K Paragraph 7.1 of the STC as a result of compliance with Section D, Part 1, paragraph 2.2.6.1 of the STC, whichever is the shorter.
And
- (g) any reduction in transmission system availability during the Relevant Period, subject to the licensee ensuring compliance with Paragraph 3, solely as a result of measures undertaken to rectify the crossing of the licensee's export cable's phases and/or to rectify inadequate joint and cable support and segregation at the onshore joint bay 1/2 (E 633707.19 N 162542.48, as detailed in Annex B to this condition) and joint bay 2/3 (E 634031.16 N 163262.89, as detailed in Annex C to this condition). For the purpose of

this paragraph, the Relevant Period is three years from the date this licence comes into force. And

- (h) any reduction in transmission system availability resulting principally from an internal cable fault attributable to a Root Cause subject to the following provisions:
 - i. the licensee shall provide details of the reduction in system availability that the licensee considers resulted from a Root Cause within 14 days of the licensee becoming aware that any such reduction was attributable to a Root Cause;
 - ii. the licensee shall provide such further information and/or analysis the Authority may require; and
 - iii. the extent of exclusion from reported system incentive performance shall be directed by the Authority and shall be based on the extent to which the Authority is satisfied that the licensee has taken reasonable steps, consistent with Good Industry Practice, to manage the impact of the fault on the availability of services provided to the System Operator in accordance with standard condition E15 (Obligation to provide transmission services) (both in anticipation of the fault and after the fault has occurred).
10. The Authority shall, by written notice to the licensee, direct that, for the purpose of calculating the reported system incentive performance ($RSIP_{i,y}$) that the value of reported system incentive performance ($RSIP_{i,y}$) shall be adjusted to the extent specified in that direction to offset the impact of the exceptional event, where:
- (a) the licensee considers that any event on the licensee's transmission system that causes a transmission service reduction has been wholly or partially caused by an exceptional event;
 - (b) the licensee has notified the Authority of such an event within 14 days of its occurrence;
 - (c) the licensee has provided details of the reduction in system availability that the licensee considers resulted from the exceptional event (including the anticipated duration of any reduction in availability) and such further information, if any, as the Authority may require in relation to such an exceptional event; and
 - (d) the Authority is satisfied that the event notified to it under sub-paragraph (b) is an exceptional event
11. For the purpose of paragraph 10, the adjustment directed by the Authority shall be based on the extent to which the Authority is satisfied that the licensee had taken reasonable steps, consistent with Good Industry Practice, to manage the impact of the event on the availability of services provided to the System Operator in accordance with standard condition E15 (Obligation to provide transmission services) (both in anticipation of the event and after the event has occurred).
12. A direction under paragraph 10 shall not have effect unless, before it is made, the Authority has given notice to the licensee:
- (a) setting out the terms of the proposed direction, including the extent to which the value of reported system availability performance for month i , and each subsequent month, should be increased to offset the impact of the exceptional event;

- (b) stating the reasons, having regard to the information provided by the licensee and Good Industry Practice, why it proposes to issue the direction; and
- (c) specifying the period (not being less than 14 days from the date of the notice) within which the licensee may make representations or objections

and the Authority has considered such representations or objections and given reasons for its decision.

13. The licensee may request that a direction issued by the Authority pursuant to paragraph 10 be modified, where the licensee considers that:
 - (a) there has been a material change to the information previously provided by the licensee in relation to the exceptional event specified in the previous direction; and
 - (b) it has notified the Authority of the material change, no later than 3 months after the end of the incentive period to which it relates.

14. For the purposes of paragraph 6, the licensee may request that the transmission system availability penalty factor ($TSAF_y$) in respect of the incentive period y , take a value:

$$TSAF_y > \left[TSIF \times \left(\frac{-PPRO_y}{AVCOL_y} \right) \right] \quad (27)$$

being an amount between 10 and 50 per cent, with the purpose of bringing forward future long term penalties.

15. In making a request pursuant to paragraph 14, the licensee shall set out:
 - (a) its reasons for making the request;
 - (b) its calculations and supporting information in support of the proposed value of $TSAF_y$ in incentive period y ; and
 - (c) its proposals for future restrictions on the value of $TSAF_{y+1}, \dots, TSAF_{y+4}$ that the licensee considers would be necessary to maintain revenue neutrality with respect to the penalty liabilities incurred in respect of incentive period y .
16. The proposed value of $TSAF_y$ and proposed restrictions on $TSAF_{y+1}, \dots, TSAF_{y+4}$ set out in the requested pursuant to paragraph 14 shall only apply if, following consultation with interested parties, the Authority gives its consent, in writing, to the licensee; and the Authority's consent shall not be unreasonably withheld.

Part B: Transmission System Availability Incentive: Supplementary Provisions

17. The licensee shall, by no later than 14 days after the end of each three month period (being the three months ending either 31 March, 30 June, 30 September and 31 December), submit to the Authority a report setting out the reported system incentive performance ($RSIP_{i,y}$) for each of the months within the three month period and the report should include the calculation of $RSIP_{i,y}$ and provide a commentary in relation to those months where reported system incentive performance ($RSIP_{i,y}$) has fallen below the monthly incentive target ($TSIT_i \times MTSA_i$).
18. The licensee shall, by no later than sixteen years after this condition comes into force, procure, to the satisfaction of the Authority, financial security for the purposes of covering future financial liabilities up to and including the closing relevant year.
19. For the purposes of paragraph 18, the licensee shall, by no later than 3 months before

the date that is sixteen years after this condition comes into force, provide to the Authority a notice specifying:

- (a) the amount of financial security that the licensee intends to procure, being no less than 50 per cent of base transmission revenue;
- (b) the form of the financial security that the licensee intends to procure;
- (c) the independent financial institution with which the financial security is to be lodged; and
- (d) the detailed terms on which the security can be called upon in the closing relevant year to meet the financial payments that have been incurred by the licensee in respect of the Transmission System Availability Incentive.

20. The Authority shall, within 2 months of receiving the notice specified in paragraph 19, indicate to the licensee whether the proposed arrangements for financial security (as specified in the notice) would be satisfactory. In the event that the Authority considers that the financial security arrangements proposed by the licensee are not satisfactory, the Authority shall set out in writing to the licensee the reasons why the proposed financial security arrangements are not satisfactory and those areas where modifications would be required. The Authority shall also set out the timescales within which the licensee is required to provide its amended proposal.
21. For the purposes of paragraph 2, $TSAP_t$ shall take the value zero except in the relevant year following the closing relevant year, where it shall be calculated in accordance with the following formula which uses the incentive periods 23 to 27 to calculate the value of the final credit payouts:

$$TSAP_{22} = \sum_{y=23}^{y=27} \frac{BR_{21}}{PR_{21}} \times TSAC_y \times PR_{t-6} \quad (28)$$

where $t=y$

Part C: Incremental Capacity Incentive Adjustment

22. For the purposes of paragraph 2, the incremental capacity incentive adjustment term (ICA_t) is derived from the following formula:

$$ICA_t = ICUA_t + (ACA_t \times RIT_t) \quad (29)$$

where:

$ICUA_t$ means the incremental capacity utilisation adjustment, as derived from the formula set out in paragraph 23; and

ACA_t means the additional capacity investment adjustment, which for the purposes of this licence shall take the value zero, but may be changed, in accordance with paragraph 24.

RIT_t means the revenue indexation adjustment term calculated in accordance with the formula specified in paragraph 4 of amended standard condition E12 – J2 (Restriction of Transmission Revenue: Revenue from Transmission Owner Services).

23. For the purposes of paragraph 22, the incremental capacity utilisation adjustment term ($ICUA_t$) shall be derived in accordance with the following formula:

$$ICUA_t = \max(0, ICRD_t \times ICU_t) \quad (30)$$

where:

$ICRD_t$ means the incremental capacity revenue driver (in £/kW) and shall take the value as defined by the formula:

$$ICRD_t = \frac{BR_t}{CCR \times PF} \times RCF \quad (31)$$

where:

CCR means the composite circuit rating based on the thermal rating of the offshore transmission cable circuit and shall take the value 316,000 kVA.

PF means the power factor (kW to kVA ratio) associated with the offshore transmission cable circuit and shall take the value of 0.95.

RCF means the risk compensation factor and shall take the value 0.31.

ICU_t means the incremental capacity utilisation term (expressed in kW) representing the amount of capacity that the licensee has agreed to make and has made available to the System Operator in accordance with standard condition E17.

24. For the purposes of paragraph 22, the additional capacity investment adjustment term (ACA_t) shall be determined by the Authority in accordance with paragraphs 25 to 27 and shall otherwise take the value zero.
25. Where the licensee has entered into an agreement with the System Operator in accordance with standard condition E17 (Obligations in relation to offers for connection etc) to provide additional capacity it shall:
 - (a) submit a notice in writing to the Authority, together with supporting evidence, setting out the revenue adjustment that it considers is required to remunerate the costs that it will incur in providing that additional capacity, which shall include (without limitation):
 - (i) the amount of additional capacity that the licensee is contractually required to make available to the System Operator;
 - (ii) the capital costs that it expects to incur in providing the additional capacity, demonstrating that such costs are not more than 20 per cent of the original investment cost incurred by the licensee in respect of the licensee's transmission system in the commencement relevant year;
 - (iii) the anticipated additional costs of operation and maintenance that are expected to be incurred as a consequence of providing the additional capacity; and
 - (iv) the costs of financing the additional investment in the licensee's transmission system.
 - (b) provide such additional information as the Authority may require to make a determination of the appropriate revenue adjustment in accordance with paragraph 27.
26. A notice referred to in paragraph 25 shall be given as soon as is reasonably practicable

after the licensee has entered an agreement with the System Operator in accordance with standard condition E17 (Obligations in relation to offers for connection etc), and, in any event, not later than three months after the end of the relevant year in which it occurs.

27. The Authority shall determine:
- (a) the revenue adjustment (ACA_t) that would be required to remunerate the efficient costs that the Authority considers to have been reasonably incurred by the licensee;
 - (b) the relevant year from which the adjustment shall apply.
28. For the purposes of paragraph 27, in determining an appropriate adjustment:
- (a) the Authority may request that the licensee provide such information that it reasonably requires for the purposes of making its determination. The licensee is required to provide such information within the timescales set out by the Authority;
 - (b) the Authority shall, following consultation with interested parties, notify the licensee in writing of its proposed determination of the adjustment to allowed transmission owner revenue (ACA_t);
 - (c) the licensee, shall have 28 days within which to make representations to the Authority's proposed determination that has been notified to it pursuant to subparagraph (b);
 - (d) the Authority, having regard to any representations made by the licensee and not withdrawn, shall propose a modification to the ACA_t pursuant to sections 11A to 11F of the Act. The proposed modification shall only take effect where made by the Authority and in accordance with sections 11A to 11F of the Act.

29. In this condition:

"financial security"	means a deposit of money, a performance bond or bank guarantee, an insurance policy or a letter of credit.
"Good Industry Practice"	means in relation to any undertaking and any circumstances, the exercise of that degree of skill, diligence, prudence and foresight which would reasonably and ordinarily be expected from a skilled and experienced operator engaged in the same type of undertaking under the same or similar circumstances.
"normal capability limits"	means the technical limits that would normally apply to the provision of its transmission services in accordance with the STC as at the date this condition comes into force.

“Root Cause”

Has the meaning defined under Amended Standard Condition E12-J3 Paragraph 44

"service restoration proposal"

means a transmission owner’s proposal, in accordance with the STC as at the date this condition comes into force, in reasonable but not excessive detail for, as appropriate:

- (a) any interim works or other actions which are able to be undertaken by such transmission owner to minimise the effect of the services reduction or services reduction risk and including, where relevant, any revised operational capability limits that would apply during the period of such services reduction or services reduction risk;
- (b) restoring the transmission services such that they are provided in accordance with their services capability specification (and to their normal capability limits); and
- (c) otherwise removing, mitigating or dealing with a services reduction risk,

including, in the case of sub-paragraphs (b) and (c), where necessary and appropriate, by proposing to amend the content of its services capability specification (including any normal capability limits).

"Transmission Entry Capacity"

means the figure specified as such for a connection site in a transmission owner construction agreement in accordance with the STC as at the date this condition comes into force.

ANNEX B to Amended Standard Condition E12 - J4 (Restriction of Transmission Revenue: Annual Revenue Adjustments)

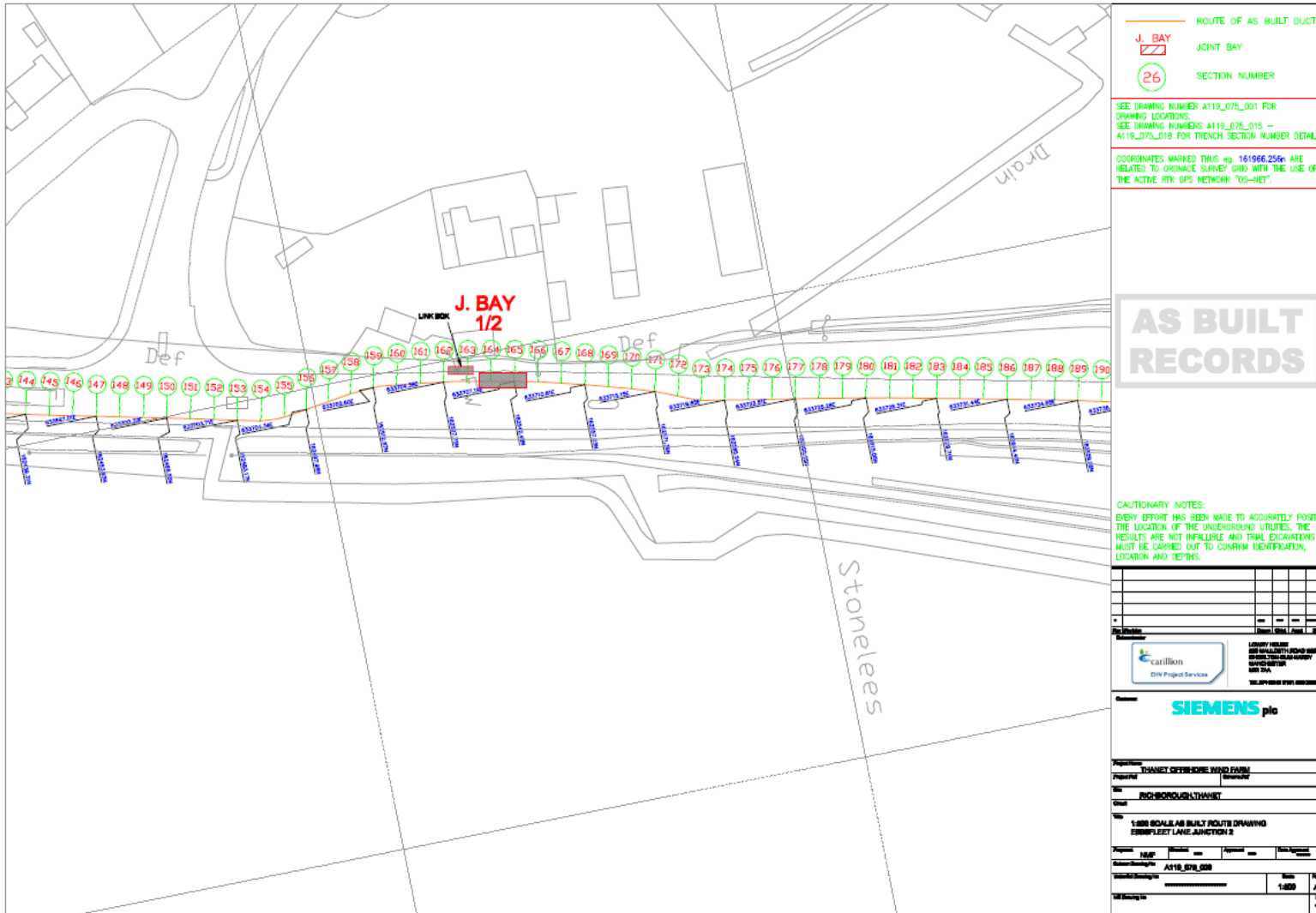

ANNEX C to Amended Standard Condition E12 - J4 (Restriction of Transmission Revenue: Annual Revenue Adjustments)

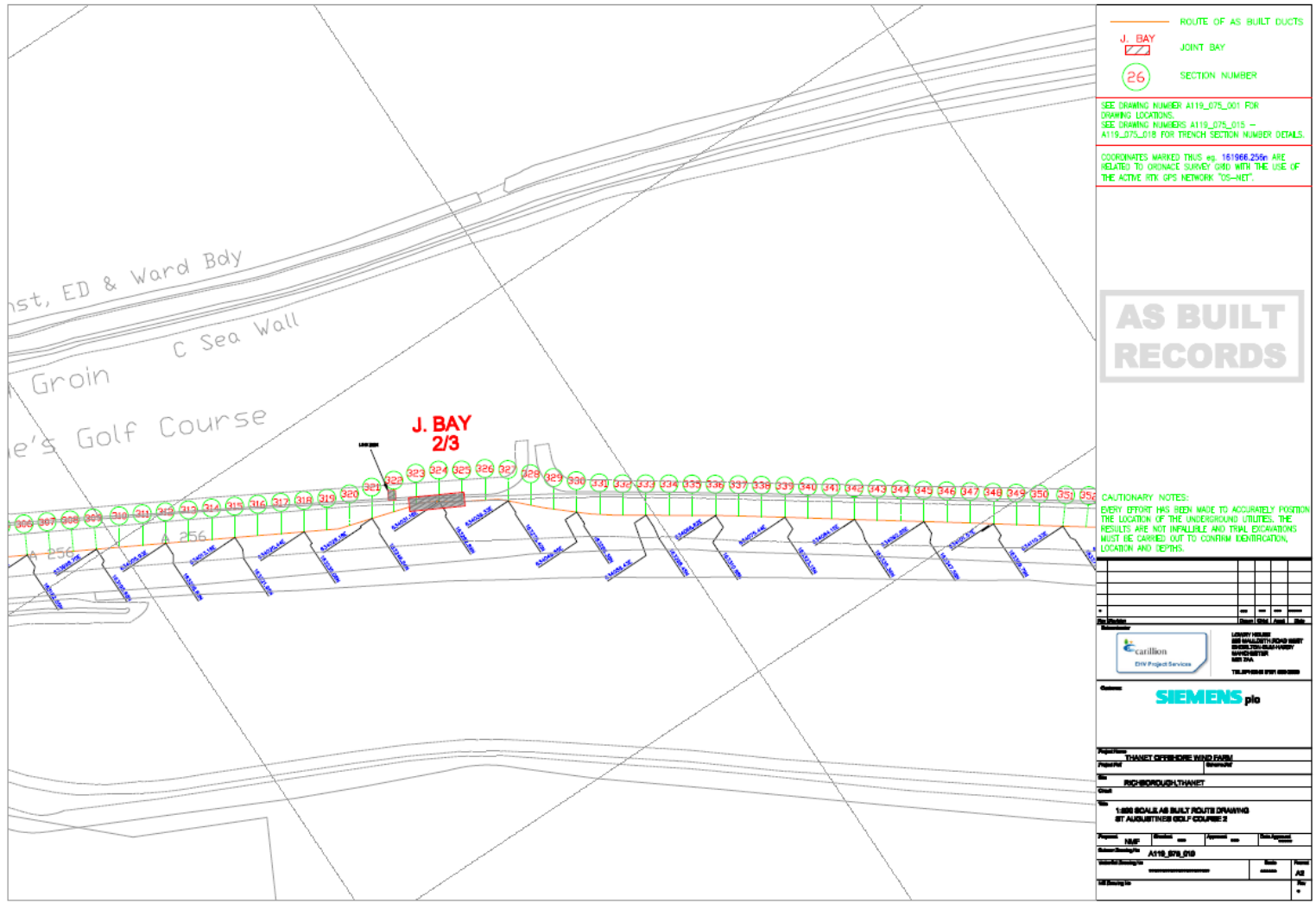

**Amended Standard Condition E12 - J5: Restriction of Transmission Revenue:
Adjustments**

1. If, in respect of any relevant year, the regulated transmission revenue (AR_t) exceeds the allowed transmission owner revenue ($OFTO_t$) by 3 per cent of the latter, the licensee shall provide a written explanation to the Authority and in the next following relevant year the licensee shall not affect any increase in charges for the provision of transmission services, the revenue from which is regulated under amended standard condition E12 - J2 (Restriction of Transmission Revenue: Revenue from Transmission Owner Services), unless it has demonstrated to the reasonable satisfaction of the Authority that the regulated transmission revenue in that next following relevant year would not be likely to exceed the allowed transmission owner revenue in that same relevant year.
2. If, in respect of any two successive relevant years, the sum of the amounts by which the regulated transmission revenue (AR_t) has exceeded the allowed transmission owner revenue ($OFTO_t$) is 4 per cent of the allowed transmission owner revenue ($OFTO_t$), then:
 - (a) the licensee shall provide a written explanation to the Authority; and
 - (b) in the next following relevant year the licensee shall, if required by the Authority, adjust its charges for the provision of transmission services, the revenue from which is regulated under the amended standard condition E12 - J2 (Restriction of Transmission Revenue: Revenue from Transmission Owner Services), such that the regulated transmission revenue (AR_t) would not be likely, in the judgment of the Authority, to exceed the allowed transmission owner revenue in that next following relevant year.
3. If, in respect of any relevant year, the licensee collects less than 97 per cent of the allowed transmission owner revenue ($OFTO_t$), the licensee shall provide a written explanation to the Authority.

Amended Standard Condition E12 - J6: Provision of Information to the System Operator

1. In the commencement relevant year, the licensee shall, as soon as reasonably practicable,
 - (a) notify the System Operator of its best estimate for the value of $OFTO_t$ in respect of the commencement relevant year; and
 - (b) notify the System Operator of its best estimate for the value of $OFTO_{t+1}$;where:

$OFTO_t$ means the allowed transmission owner revenue in the relevant year t calculated in accordance with amended standard condition E12 - J2 (Restriction of Transmission Revenue: Revenue from Transmission Owner Services).
2. In each relevant year subsequent to the commencement relevant year, the licensee shall, on or before 1 November (or such later date as the Authority may direct),
 - (a) notify the System Operator of its latest best estimate for the value of $OFTO_t$; and
 - (b) notify the System Operator of its latest best estimate for the value of $OFTO_{t+1}$.
3. The licensee shall, at all times, keep under review the estimates notified to the System Operator pursuant to paragraphs 1 or 2. If at any time, the licensee reasonably considers that the values of $OFTO_t$ and/or $OFTO_{t+1}$, notified to the System Operator will be significantly different from the estimates previously notified to the System Operator, the licensee shall notify the System Operator of the revised values for $OFTO_t$ and/or $OFTO_{t+1}$ as soon as reasonably practicable.
4. In each relevant year subsequent to the commencement relevant year, the licensee shall, by 30 June (or such later date as the Authority may direct), provide a statement to the Authority showing:
 - (a) the values of $OFTO_t$ and $OFTO_{t+1}$ notified to the System Operator in accordance with paragraph 1 or paragraph 2 of this condition in the relevant year $t-1$; and
 - (b) any revised values of $OFTO_t$ and $OFTO_{t+1}$ notified to the System Operator in accordance with paragraph 3 of this condition in the relevant year $t-1$.

Amended Standard Condition E12 - J7: Duration of the Revenue Restriction

Provisions

1. The charge restriction conditions shall apply so long as this licence continues in force but shall cease to have effect (in whole or in part, as the case may be) if the licensee delivers to the Authority a disapplication request made in accordance with paragraph 2 and:
 - (a) the Authority agrees in writing to the disapplication request; or
 - (b) the application of those conditions (in whole or in part) is terminated by notice given by the licensee in accordance with either paragraph 4 or paragraph 5.
2. A disapplication request pursuant to this condition shall:
 - (a) be in writing addressed to the Authority;
 - (b) specify those of the charge restriction conditions (or any part or parts thereof) to which the request relates; and
 - (c) state the date (not being earlier than the date specified in paragraph 3) from which the licensee wishes the Authority to agree that the specified charge restriction conditions shall cease to have effect ("the disapplication date").
3. Save where the Authority agrees otherwise, no disapplication following delivery of a disapplication request pursuant to this condition shall have effect earlier than the date which is the later of:
 - (a) a date being not less than 12 months after delivery of the disapplication request; and
 - (b) the closing date, being not less than 20 calendar years after the date of grant of this offshore transmission licence.
4. If the Authority has not made a reference to the Competition Commission under Section 12 of the Act relating to the modification of the charge restriction conditions before the beginning of the period of 6 months which will end with the disapplication date, the licensee may deliver written notice to the Authority terminating the application of such of the charge restriction conditions (or any part or parts thereof) as are specified in the disapplication request with effect from the disapplication date or a later date.
5. If the Competition Commission makes a report on a reference made by the Authority relating to the modification of the revenue restriction (or any part or parts thereof) specified in the disapplication request and such report does not include a conclusion that:
 - (a) the cessation of such revenue restriction, in whole or in part, operates or may be expected to operate against the public interest; or
 - (b) that any adverse effects specified by the Competition Commission could be remedied or prevented by such modifications of the relevant conditions as are specified in the report;

the licensee may, within 30 days after the publication of the report by the Authority in accordance with Section 13 of the Act, deliver to it written notice terminating the application of such revenue restriction (or any part or parts thereof) with effect from the disapplication date or a later date.

Amended Standard Condition E12 - J8: Allowances in respect of Security Costs

1. At any time during a security period, the licensee may give notice in writing to the Authority suspending, with effect from the date of receipt of the notice by the Authority, application of such of the charge restriction conditions as may be specified in the notice, for the unexpired term of the security period.
2. At any time during a security period, the Authority may (having regard to its duties under the Act) by means of directions:
 - (a) suspend or modify for the unexpired term of the security period the charge restriction conditions or any part or parts thereof; or
 - (b) introduce for the unexpired term of the security period new charge restriction conditions;

in either case, so as to make such provision as in the opinion or estimation of the Authority is requisite or appropriate to enable the licensee to recover by means of a uniform percentage increase on all charges made in the course of the licence an amount estimated as being equal to the licensee's allowed security costs during such period, and the licensee shall comply with the terms of any directions so issued.
3. Subject to paragraphs 4 and 6, the licensee shall in any relevant year be entitled to recover an aggregate amount equal to the licensee's allowed security costs in that year or (in so far as not previously recovered) any previous year, by means of appropriate equitable increases in the charges made by the licensee in the course of the transmission business.
4. Paragraph 3 shall not apply in so far as such licensee's allowed transmission related security costs:
 - (a) were otherwise recovered by the licensee; or
 - (b) were taken into account by the Authority in setting the charge restriction conditions by means of directions issued under paragraph 2.
5. The licensee shall following the end of each relevant year provide to the Authority details in respect of that relevant year of:
 - (a) the aggregate amounts charged under paragraph 3 on account of the licensee's allowed security costs; and
 - (b) the basis and calculation underlying the increases in charges made by the licensee in the course of the transmission business.
6. Where the Authority is satisfied that the licensee has recovered amounts in excess of the licensee's allowed security costs, the Authority may issue directions requiring the licensee to take such steps as may be specified to reimburse customers of the licensee for the excess amounts charged to them, and the licensee shall comply with any directions so issued.
7. No amounts charged by the licensee under this condition (whether or not subsequently required to be reimbursed) shall be taken into account for the purpose of applying the charge restriction provisions of amended standard condition E12 - J2 (Restriction of Transmission Revenue: Revenue from Transmission Owner Services).

8. In this condition:

"allowed security cost"

means any cost allowed by the Authority (upon receipt of such information, including a certificate from the auditors, as the Authority may request) as being a cost which is directly attributable to any action taken or omitted to be taken by the licensee in its capacity as holder of the licence for the purpose of complying with directions issued by the Secretary of State under section 34(4) of the Act.

"security period"

means a period commencing on the date on which any direction issued by the Secretary of State under section 34(4) of the Act enters effect and terminating on the date (being not earlier than the date such direction, as varied, is revoked or expires) as the Authority, after consultation with such persons (including without limitation, licence holders liable to be principally affected) as it shall consider appropriate, may with the consent of the Secretary of State by notice to all licence holders determine after having regard to the views of such persons.

Amended Standard Condition E12 - J9: Basis of Transmission Owner Charges

1. The licensee shall as soon as practicable during the commencement relevant year and, in any event, not later than such date as the Authority shall specify, prepare a statement approved by the Authority setting out the basis upon which charges will be made:
 - (a) for transmission owner services;
 - (b) for connection to the licensee's transmission system, such statement to be in such form and to contain such detail as shall be necessary to enable the System Operator to make a reasonable estimate of the charges to which it would become liable for the provision of such services, and (without prejudice to the foregoing) including such of the information set out in paragraph 2 as is required by such paragraph to be included in the relevant statement; and
 - (c) for outage changes.
2. The statement referred to in paragraph 1 shall in respect of connections to the licensee's transmission system include:
 - (a) a schedule listing those items (including the carrying out of works and the provision and installation of electric lines or electrical plant or meters) of significant cost liable to be required for the purpose of connection (at entry or exit points) to the licensee's transmission system for which site specific charges may be made or levied and including (where practicable) indicative charges for each such item and (in other cases) an explanation of the methods by which and the principles on which such charges will be calculated;
 - (b) the methods by which and the principles on which site specific charges will be made in circumstances where the electric lines or electrical plant to be installed are (at the licensee's discretion) of greater size or capacity than that required;
 - (c) the methods by which and the principles on which any charges (including any capitalised charge) will be made for maintenance, replacement and repair required of electric lines, electrical plant or meters provided and installed for making a connection to the licensee's transmission system;
 - (d) the methods by which and the principles on which any charges will be made for disconnection from the licensee's transmission system and the removal of electrical plant, electric lines and ancillary meters following disconnection; and
 - (e) such other matters as shall be specified in directions issued by the Authority from time to time for the purpose of this condition.
3. Site specific charges for those items referred to in paragraph 2 shall be set at a level which will enable the licensee to recover:
 - (a) the appropriate proportion of the costs directly or indirectly incurred in carrying out any works, the extension or reinforcement of the licensee's transmission system or the provision and installation, maintenance, replacement and repair or (as the case may be) removal following disconnection of any electric lines, electrical plant, meters or other items; and
 - (b) a reasonable rate of return on the capital represented by such costs.
4. In addition to, and without prejudice to, the licensee's obligations under paragraph 1, the licensee shall, upon being directed to do so in directions issued by the Authority from time to time for the purposes of this condition and within such period as shall be

specified in the directions, prepare a statement or statements approved by the Authority providing that charges:

- (a) for transmission owner services;
- (b) for connection to the licensee's transmission system; and
- (c) for outage changes

will be made on such basis as shall be specified in the directions and such statement or statements shall be in such form and contain such detail as shall be necessary to enable the System Operator to make a reasonable estimate of the charges to which it would become liable for the provision of such services and (without prejudice to the foregoing) including such information as shall be specified in the directions. Each statement prepared in accordance with this paragraph shall, with effect from the date on which it is approved by the Authority or such later date as the Authority shall specify, replace the corresponding statement prepared by the licensee in accordance with paragraph 1 or, as the case may be, this paragraph (as from time to time revised in accordance with paragraph 5) which is in force at such date and the licensee shall, with effect from such date make charges in accordance with the statement (as from time to time revised in accordance with paragraph 5) which has replaced such corresponding statement.

5. The licensee may periodically revise the statements in accordance with paragraphs 1 and 4 and shall, at least once in every year this licence is in force, make any necessary revisions to such statements in order that the information set out in the statements shall continue to be accurate in all material respects.
6. The licensee shall send a copy of the statements prepared in accordance with paragraphs 1 and 4, and of each revision of such statements in accordance with paragraph 5, to the Authority. Each such revision shall require to be approved by the Authority and shall not become effective until approved by the Authority.
7. The licensee shall give or send a copy of the statements prepared in accordance with paragraphs 1 and 4 or (as the case may be) of the latest revision of such statements in accordance with paragraph 5 approved by the Authority pursuant to such paragraphs to any person who requests a copy of such statement or statements.
8. The licensee may make a charge for any statement given or sent pursuant to paragraph 7 of an amount reflecting the licensee's reasonable costs of providing such a statement which shall not exceed the maximum amount specified in any directions issued by the Authority for the purposes of this condition.

Amended Standard Condition E12- J10: Excluded Services

1. There may be treated as excluded services provided by the licensee in its transmission business such services in respect of which charges are made:
 - (a) which fall within paragraph 6; or
 - (b) which:
 - (i) do not fall within paragraph 2 of this amended standard condition; and
 - (ii) may (subject to paragraph 7) be determined by the licensee as falling under one of the principles set out in paragraphs 3 to 5 of this amended standard condition.
2. No service provided by the licensee as part of its transmission business shall be treated as an excluded service in so far as it relates to the provision of services remunerated under charges for transmission owner services in accordance with amended standard condition E12 - J9 (Basis of Transmission Owner Charges) including (without prejudice to the foregoing):
 - (a) the making available of transmission owner services;
 - (b) the carrying out of works for the installation of electric lines or electrical plant for the purpose of maintaining or upgrading the licensee's transmission system (not otherwise payable in respect of connections to the licensee's transmission system);
 - (c) the carrying out of works or the provision of maintenance or repair in relation to the licensee's transmission system for the purpose of enabling the licensee to comply with amended standard condition E13 (System Operator – Transmission Owner Code) and standard condition E16 (Transmission system security standard and quality of service), the Electricity Safety, Quality and Continuity Regulations 2002 or any regulations made under section 29 of the Act or any other enactment relating to safety or standards applicable in respect of the transmission business; and
 - (d) the provision, installation and maintenance of any meters, switchgear or other electrical plant ancillary to the licensee's provision of transmission owner services.
3. The whole or an appropriate proportion (as the case may be) of the charges of the type described in amended standard condition E12 - J9 (Basis of Transmission Owner Charges) and borne by any person as connection charges in respect of connections made after the grant of this licence and not remunerated as part of the transmission owner services under amended standard condition E12 - J2 (Restriction of Transmission Revenue: Revenue from Transmission Owner Services) may be treated as excluded services.
4. There may be treated as an excluded service charge for the relocation of electric lines or electrical plant and the carrying out of works associated therewith pursuant to a statutory obligation (other than under section 9(2) of the Act) imposed on the licensee.
5. There may with the approval of the Authority be treated as an excluded service any service of a type not above referred to which:
 - (a) consists in the provision of services for the specific benefit of a third party requesting the same; and
 - (b) is not made available by the licensee as a normal part of the transmission business

remunerated under amended standard condition E12 - J2 (Restriction of Transmission Revenue: Revenue from Transmission Owner Services).

6. Services may be regarded as excluded services where the charges are the net costs reasonably incurred by the licensee as a result of any outage change.
7. Where the Authority is satisfied that in light of the principles set out in paragraphs 3 to 6 inclusive any service treated by the licensee as an excluded service should not be so treated, the Authority shall issue directions to that effect, and such service shall cease to be treated as an excluded service with effect from the date of issue of such directions or such earlier date as may be specified in the directions (being not earlier than the commencement of the relevant year to which the information relating to excluded services last furnished pursuant to the offshore regulatory reporting - regulatory instructions and guidance directed by the Authority pursuant to amended standard condition E12 - D1 (Offshore Regulatory Reporting) related, unless such information, or any such information provided earlier, was incorrect or misleading in any material respect, as may be specified in the directions).
8. Any revenues received by the licensee from the System Operator in respect of a non-chargeable outage change shall not be regarded as excluded service revenues under this condition.
9. The charges referred to in paragraph 6 shall be those declared to the System Operator by the licensee and which are agreed by the System Operator, or where there is a failure to agree, as determined by the Authority following the provision by the licensee of such information as the Authority may reasonably request.

10. In this condition:

"non-chargeable outage change"	means a change to the outage plan notified by the System Operator which the licensee and the System Operator agree.
"original change"	means a change to the outage plan requested by the licensee.

"outage change"

means a change notified to the licensee by the System Operator on or after week 49 of the calendar year to the outage plan, as updated from time to time in accordance with the STC as at the date this condition comes into force, other than:

- (a) the original change, and
- (b) such changes notified to the licensee by the System Operator which:
 - (i) the licensee and the System Operator agree are necessary in order to give effect to the original change, or
 - (ii) where there is a failure to agree, the Authority determines are necessary in order to give effect to the original change; and
- (c) without prejudice to sub-paragraphs (a) and (b) above, a non-chargeable outage change.

"outage plan"

means the plan for the placement of outages for each financial year developed and maintained by System Operator in accordance with the STC as at the date this condition comes into force.

Amended Standard Condition E12-J11: The Network Innovation Competition

Introduction

1. The purpose of this condition is to establish arrangements known as the Network Innovation Competition (NIC) with respect to the funding of innovative low carbon or environmental projects carried out by the licensee.
2. This condition also makes provision for arrangements relating to the regulation, administration, and governance of the NIC.

Part A: Function of the Network Innovation Competition (NIC)

3. The function of the NIC is to enable the licensee to fund Eligible NIC Projects by means of payments received from the System Operator in accordance with the determination process described in Part B below as varied, where appropriate, by the Funding Return Mechanism described in Part C below.

Part B: The NIC Funding Mechanism

4. The NIC Funding Mechanism is the mechanism by which the licensee receives the amount of authorised NIC Funding in any Relevant Year from the System Operator, less any Funding Return as described in Part C and in accordance with the NIC Governance Document.

Part C: The Funding Return Mechanism

5. The Funding Return Mechanism relates to payments to be made by the licensee to the System Operator, in each of the following cases to such extent (if any) as may be relevant, of:
 - (a) Halted Project Revenues;
 - (b) Disallowed Expenditure; and
 - (c) Returned Royalty Income.
6. The Funding Return is the total amount, in respect of the licensee, of any amounts arising under paragraph 5.
7. Halted Project Revenues are any revenues received by the licensee from the System Operator under the NIC Funding Mechanism in respect of an Eligible NIC Project which have not yet been spent, or otherwise committed, at the time that the Authority requires that project to be halted in accordance with the applicable provisions of the NIC Governance Document or the terms of the relevant Project Direction.
8. Disallowed Expenditure is any revenue received by the licensee from the System Operator under the NIC Funding Mechanism that the Authority determines has not been spent in accordance with the applicable provisions of the NIC Governance Document or the terms of the relevant Project Direction.
9. Returned Royalty Income is revenue earned from intellectual property generated through Eligible NIC Projects undertaken by the licensee, less Directly Attributable Costs, and that is payable to customers under the NIC Funding Mechanism, as calculated in accordance with the provisions of the NIC Governance Document.
10. For the purposes of paragraph 9, Directly Attributable Costs are costs relating to the maintenance and management of intellectual property generated through Eligible NIC Projects undertaken by the licensee that have not been otherwise remunerated under

any of the arrangements by which the licensee recovers its allowed transmission owner revenue (OFTOt) from the System Operator, Excluded Services as defined in amended standard condition E12-J10 (Excluded Services), or the NIC Funding Mechanism.

11. In each Relevant Year *t*, in accordance with the appropriate provisions of the NIC Governance Document, the Authority will calculate and then, by direction given to the licensee, will specify:
 - (a) the amount of any Funding Return that the licensee must pay to the System Operator; and
 - (b) the manner in which and the timescale over which that amount is to be so paid.
12. The licensee must comply with any direction that is issued by the Authority under paragraph 11.

Part D: Determination of the NIC term

13. The NIC term is the net amount of NIC Funding less any Funding Return for the Relevant Year *t* that is to be paid to the licensee by the System Operator, or vice versa, in compliance with the determination made for that purpose in a direction issued by the Authority pursuant to the provisions of Part D of Special Condition 3I (The Network Innovation Competition) in the Transmission Licence held by the System Operator.
14. The NIC Funding to which paragraph 4 refers is the proportion (if any) of total NIC Funding raised by the System Operator from its Transmission Network Charges in accordance with the NIC Funding Mechanism that the Authority determines is to be allocated to the licensee in respect of its Eligible NIC Projects, as adjusted by the amount of any Funding Return (as to which, see Part C above).
15. In each Relevant Year *t*, as provided for by the NIC Governance Document and in accordance with the appropriate provisions of the System Operator's Transmission Licence the Authority will calculate and then, by direction given to the licensee and other electricity Transmission Licensees, will specify, in accordance with the appropriate provisions set out in the NIC Governance Document:
 - (a) the net amount of the NIC term (whether negative or positive);
 - (b) how the amount of that term has been calculated, taking account of any Funding Return; and
 - (c) the manner in which and the timescale over which the System Operator is required to transfer that amount to the licensee or vice versa.

Part E: The NIC Governance Document

16. The Authority will issue, and may from time to time revise, a document, to be known as the NIC Governance Document, for purposes connected with the regulation, governance, and administration of the NIC.
17. The NIC Governance Document may, without limitation, make appropriate provision about or impose requirements in respect of:
 - (a) the eligibility criteria to be applied by, and information to be provided to, the Authority in relation to the assessment and approval of proposed NIC Projects;
 - (b) the evaluation criteria against which the funding of such projects will be assessed and approved (where necessary);

- (c) the process and procedures that will be in place for the assessment, approval, and financing of such projects' funding (where necessary);
 - (d) arrangements to ensure that relevant learning from the implementation of Eligible NIC Projects can be captured and disseminated by the licensee to other electricity Transmission Licensees;
 - (e) the nature of the reporting obligations in respect of such projects (which may include reporting in respect of the funding and the completion of such projects, as well as reporting on compliance with this condition and the provisions of the NIC Governance Document);
 - (f) arrangements relating to the treatment of intellectual property rights including Returned Royalty Income in respect of Eligible NIC Projects; and
 - (g) any other matters relating to the regulation, governance, or administration of the NIC.
18. Where provisions of the NIC Governance Document require the compliance of the Licensee, the Licensee must comply with those provisions as if the NIC Governance Document were part of this condition.

Part F: Procedure for issuing and revising the NIC Governance Document

19. Before issuing the NIC Governance Document under this condition, the Authority, by Notice given to the licensee and other electricity Transmission Licensees with a condition of similar effect to this condition in their license, must:
- (a) state that it proposes to issue the NIC Governance Document, and specify the date on which it proposes that the document should take effect;
 - (b) set out the text of the NIC Governance Document and the Authority's reasons for proposing to issue it; and
 - (c) specify the date (which must not be less than a period of 28 days from the date of the notice) within which representations with respect to the proposed NIC Governance Document may be made.
20. The Authority will consider any representations that are duly made.
21. The requirements of paragraphs 19 and 20 may be satisfied by action taken before, as well as by action taken after, the commencement of this condition.
22. In paragraph 19, "issuing the NIC Governance Document" includes issuing any revision of the document, and the procedure provided for under that paragraph will apply to any such revision.

Part G: Interpretation

23. For the purposes of this condition:

"Disallowed Expenditure"	has the meaning given to that term in paragraph 8 of this condition.
"Directly Attributable Costs"	has the meaning given to that term in paragraph 10 of this condition.

"Eligible NIC Project"	means a project undertaken by the licensee or any other transmission licensee that appears to the Authority to satisfy such requirements of the NIC Governance Document as are necessary to enable the project to be funded under the NIC Funding Mechanism.
"Funding Return"	has the meaning given to that term in paragraph 6 of this condition.
"Funding Return Mechanism"	has the meaning given to that term in paragraph 5 of this condition.
"Halted Project Revenues"	has the meaning given to that term in paragraph 7 of this condition.
"NIC Funding"	has the meaning given to that term in paragraph 14 of this condition.
"NIC Funding Mechanism"	Refers to the arrangements (pursuant to amended standard condition E12-J11 of its transmission licence) for the recovery by the System Operator through its Transmission Network Charges of the amount of total authorised NIC Funding in any Relevant Year and the apportionment of that amount between the System Operator, the licensee, and other Transmission Licensees.
"Returned Royalty Income"	has the meaning given to that term in paragraph 9 of this condition.
"NIC Governance Document"	means the document issued by the Authority under Part E of this condition, subject to the requirements of Part F, relating generally to the NIC and including matters relating to the operation of the NIC Funding Mechanism.
"Project Direction"	means a direction issued by the Authority pursuant to the NIC Governance Document setting out the terms to be followed in relation to an Eligible NIC Project as a condition of its funding under the NIC Funding Mechanism.
"Transmission Network Charges"	means charges levied by the System Operator in respect of the provision of Transmission Network Services.

24. Expressions defined in paragraph 23 above are to be read and given effect subject to any further explanation or elaboration that might be set out in the NIC Governance Document in relation to such expressions.

Condition E13: System Operator – Transmission Owner Code

Insert text below after paragraph 4

5. Where the Authority issues a direction under this paragraph, any reference to a special condition in the STC or the STC Framework Agreement shall have such effect in relation to this licence as if "Amended Standard Condition" were construed as "Special Condition" as set out below:

<u>Amended Standard Condition reference</u>	<u>STC reference</u>
Amended Standard Condition E12 – A1: Definitions and Interpretation	Special Condition A1: Definitions and Interpretation
Amended Standard Condition E12 – A2: Market Rate Revenue Adjustment	Special Condition A2: Market Rate Revenue Adjustment
Amended Standard Condition E12 – A3: Post Tender Revenue Adjustment	Special Condition A3: Post Tender Revenue Adjustment
Amended Standard Condition E12 – B1: Transmission System Area	Special Condition B1: Transmission System Area
Amended Standard Condition E12 – B2: Activities Restrictions	Special Condition B2: Activities Restrictions
Amended Standard Condition E12 – C1: Conduct of Transmission Business	Special Condition C1: Conduct of Transmission Business
Amended Standard Condition E12 – C2: Separation and Independence of the Transmission Business	Special Condition C2: Separation and Independence of the Transmission Business
Amended Standard Condition E12 – C3: Restriction on use of certain information	Special Condition C3: Restriction on use of certain information
Amended Standard Condition E12 – C4: Appointment of Compliance Officer	Special Condition C4: Appointment of Compliance Officer
Amended Standard Condition E12 – D1: Offshore Regulatory Reporting	Special Condition D1: Offshore Regulatory Reporting
Amended Standard Condition E12 – J1: Restriction of Transmission Revenue: Definitions	Special Condition J1: Restriction of Transmission Revenue: Definitions
Amended Standard Condition E12 – J2: Restrictions of Transmission Revenue: Revenue from Transmission Owner Services	Special Condition J2: Restrictions of Transmission Revenue: Revenue from Transmission Owner Services
Amended Standard Condition E12 – J3: Restriction of Transmission Revenue:	Special Condition J3: Restriction of Transmission Revenue: Allowed Pass-

Allowed Pass-through Items	through Items
Amended Standard Condition E12 – J4: Restriction of Transmission Revenue: Annual Revenue Adjustment	Special Condition J4: Restriction of Transmission Revenue: Annual Revenue Adjustment
Amended Standard Condition E12 – J5: Restriction of Transmission Revenue: Adjustments	Special Condition J5: Restriction of Transmission Revenue: Adjustments
Amended Standard Condition E12 – J6: Provision of Information to the System Operator	Special Condition J6: Provision of Information to the System Operator
Amended Standard Condition E12 – J7: Duration of the Revenue Restriction Provisions	Special Condition J7: Duration of the Revenue Restriction Provisions
Amended Standard Condition E12 – J8: Allowances in respect of Security Costs	Special Condition J8: Allowances in respect of Security Costs
Amended Standard Condition E12 – J9: Basis of Transmission Owner Charges	Special Condition J9: Basis of Transmission Owner Charges
Amended Standard Condition E12 – J10: Excluded Services	Special Condition J10: Excluded Services
Amended Standard Condition E12 – J11: The Network Innovation Competition	Special Condition J11: The Network Innovation Competition

6. For the purposes of Section E of this licence:

"STC"	means the system operator transmission owner code, being a document which sets out terms as between STC parties whereby the national electricity transmission system and each STC party's transmission system forming part thereof is to be planned, developed or operated and transmission services are to be provided together with any associated arrangements.
-------	--