

# Offshore Electricity Transmission: Final Consultation on implementation of the Generator Commissioning Clause in the Energy Act 2013

---

## **Annex 2**

### **Proposed modifications to the Grid Code**

**2 April 2014**

| <b>Proposal</b>   | <b>Corresponding proposed Grid Code modification</b>  |
|---|---|
| <p>Extend the process for assessing compliance with the Grid Code to generator built offshore transmission systems.</p> <p>Introduce a new obligation on NGET to issue an ION Part A and ION Part B in respect of a generator built offshore transmission system.</p> <p>Extend the requirements for system energisation to generator built offshore transmission systems.</p>                                | <p>Proposed amendments to the Compliance Process (CP) within the Grid Code</p> <p>Further proposed changes to the definition of "Energisation"; "Interim Operational Notification or ION"; "Interface Point"; "Notification of User's Intention to Synchronise" and "User System"</p> |
| <p>Clarify that a generator built offshore transmission system will form an Offshore Transmission System but will not form part of the National Electricity Transmission System (NETS) until that system transfer to an OFTO</p>  | <p>Amendment to the definition of "National Electricity Transmission System"; "Offshore Transmission System"; "Offshore Transmission System User Assets or OTSUA"</p>   |
| <p>Clarify the procedures to be followed when testing generator built transmission systems, prior to transfer to the OFTO.</p>  | <p>Amendments to Operating Code 5 (OC5)</p>   |
| <p>Clarify that the data exchange requirements that apply when configuring Connection Sites<sup>1</sup> will also apply at the Transmission Interface Site<sup>2</sup> for generator built offshore transmission assets until those assets transfer to the OFTO.</p> <p>Set out the data exchange arrangements for generator built transmission systems in relation to Events and Operations<sup>3</sup>.</p> | <p>Amendments to Operating Code 7 (OC7)</p>   |
| <p>Clarify the safety arrangements to apply to generator built offshore transmission systems, until transfer to the OFTO.</p>   | <p>Amendments to Operating Code 8 (OC8); Operating Code 8 Appendix 1 (OC8A) and Operating Code 8 Appendix 2 (OC8B)</p> <p>Further proposed changes to the definition of "E&amp;W User"; "Safety Co-ordinator" and "Scottish User"</p>   |
| <p>Clarify that OTSDUW Plant and Apparatus will be operated by the developer as required by Grid Code and any bilateral agreement, including the provision of reactive power<sup>4</sup>.</p>   | <p>New clause added to Balancing Code 2 (BC2) and amendments to the Compliance Process (CP) within the Grid Code.</p>   |
| <p>Clarify that a developer must submit a description of OTSDUW Plant and Apparatus with any Modification<sup>5</sup></p>   | <p>Amendments to the Planning Code (PC) within the Grid Code.</p>   |
| <p>Clarify that the developer is required to comply with the Connection Conditions (CC) of the Grid Code in relation to a</p>   | <p>Proposed amendments to the Connection Conditions (CC) of the Grid Code</p>   |

<sup>1</sup> Defined in the Glossary and Definitions section of the Grid Code

<sup>2</sup> Defined in the Glossary and Definitions section of the Grid Code

<sup>3</sup> Defined in the Glossary and Definitions section of the Grid Code

<sup>4</sup> Please see chapter 3 for further discussion on payment for reactive power provided by OTSDUW Plant and Apparatus.

<sup>5</sup> Defined in the Glossary and Definitions section of the Grid Code

| <b>Proposal</b>  | <b>Corresponding proposed Grid Code modification</b>  |
|--|---|
| generator built transmission system, until transfer to the OFTO.   |   |
| Clarify that, where a developer wishes to connect to an onshore distribution, the arrangements will be the same as those for connection to an onshore transmission system. | Proposed amendments to paragraph CP4.1 of the Compliance Process (CP) within the Grid Code            |
| Make clear that commissioning the OTSDUW is covered by the OSTDUW Arrangements consistent with the CUSC.   | Proposed amendment to the definition of and "OTSDUW Arrangements" in Grid Code Glossary & Definitions |

## Changes to Grid Code Glossary & Definitions

Amended definitions at Grid Code Glossary & Definitions as follows:

|  |   |
|--|---|
| <b>E&amp;W User</b>                                    | A <b>User</b> in <b>England</b> and <b>Wales</b> or any <b>Offshore User</b> who owns or operates <b>Plant</b> and/or <b>Apparatus</b> connected <u>(or which will at the <b>OTSUA Transfer Time</b> be connected)</u> to an <b>E&amp;W Offshore Transmission System</b> .  |
| <b>Energisation Operational Notification or EON</b>    | A notification (in respect of <b>Plant</b> and <b>Apparatus</b> <u>(including <b>OTSUA</b>)</u> which is directly connected to the <b>National Electricity Transmission System</b> ) from <b>NGET</b> to a <b>User</b> confirming that the <b>User</b> can in accordance with the <b>Bilateral Agreement</b> and/or <b>Construction Agreement</b> , energise such <b>User's Plant</b> and <b>Apparatus</b> (including <b>OTSUA</b> ) specified in such notification.  |
| <b>Interim Operational Notification or ION</b>         | <p>A notification from <b>NGET</b> to a <b>Generator</b> or <b>DC Converter Station</b> owner acknowledging that the <b>User</b> has demonstrated compliance, except for the <b>Unresolved Issues</b>;</p> <p>(a) with the Grid Code, and</p> <p>(b) where applicable, with Appendices F1 to F5 of the <b>Bilateral Agreement</b>,</p> <p>in each case in respect of the <b>Plant</b> and <b>Apparatus</b> <u>(including <b>OTSUA</b>)</u> specified in such notification <u>and provided that in the case of the <b>OTSDUW Arrangements</b> such notification shall be provided to a <b>Generator</b> in two parts dealing with the <b>OTSUA</b> and <b>Generator's Plant</b> and <b>Apparatus</b> (called respectively "<b>Interim Operational Notification Part A</b>" or "<b>ION A</b>" and "<b>Interim Operational Notification Part B</b>" or "<b>ION B</b>") as provided for in the <b>CP</b>.</u></p>                         |
| <b>National Electricity Transmission System</b>        | The <b>Onshore Transmission System</b> and, <u>where owned by <b>Offshore Transmission Licensees</b></u> , <b>Offshore Transmission Systems</b> .   |
| <b>Notification of User's Intention to Synchronise</b> | A notification from a <b>Generator</b> or <b>DC Converter Station</b> owner to <b>NGET</b> informing <b>NGET</b> of the date upon which <u>any <b>OTSUA</b></u> , a <b>Generating Unit(s)</b> , <b>CCGT Module(s)</b> , <b>Power Park Module(s)</b> or <b>DC Converter(s)</b> will be ready to be <b>Synchronised</b> to the <b>Total System</b> .  |
| <b>Offshore Transmission System</b>                    | A system consisting (wholly or mainly) of high voltage electric lines <del>owned or operated by an <b>Offshore Transmission Licensee</b></del> and used for the transmission of electricity from one <b>Power Station</b> to a sub-station or to another <b>Power Station</b> or between sub-stations, and includes any <b>Plant</b> and <b>Apparatus</b> <u>(including <b>OTSUA</b>)</u> and meters <del>owned or operated by any <b>Offshore Transmission Licensee</b></del> in connection with the transmission of electricity but does not include any <b>Remote Transmission Assets</b> . An <b>Offshore Transmission System</b> extends from the <b>Interface Point</b> , or the <b>Offshore Grid Entry Point(s)</b> and may include <b>Plant</b> and <b>Apparatus</b> located <b>Onshore</b> and <b>Offshore</b> and, where the context permits, references to the <b>Offshore Transmission System</b> includes <b>OTSUA</b> . |
| <b>OTSDUW DC Converter</b>                             | A <b>Transmission DC Converter</b> designed and/or constructed and/or installed by a <b>User</b> under the <b>OTSDUW Arrangements</b> <u>and/or operated by the <b>User</b> until the <b>OTSUA Transfer Time</b></u> .  |

|   |   |
|---|---|
| OTSDUW Arrangements                               | The arrangements whereby certain aspects of the design, consenting, construction <del>and/or</del> installation <u>and/or commissioning</u> of transmission assets are capable of being undertaken by a User prior to the transfer of those assets to a Relevant Transmission Licensee under an Offshore Tender Process.  |
| Offshore Transmission System User Assets or OTSUA | OTSDUW Plant and Apparatus constructed and/or installed by a User under the OTSDUW Arrangements <u>which form an Offshore Transmission System</u> that once transferred to a Relevant Transmission Licensee under an Offshore Tender Process will <del>form the Offshore Transmission System</del> <u>become part of the National Electricity Transmission System.</u>  |
| Safety Co-ordinator                               | A person or persons nominated by a Relevant E&W Transmission Licensee and each E&W User in relation to Connection Points <u>(or in the case of OTSUA operational prior to the OTSUA Transfer Time, Transmission Interface Points)</u> on an E&W Transmission System and/or by the Relevant Scottish Transmission Licensee and each Scottish User in relation to Connection Points <u>(or in the case of OTSUA operational prior to the OTSUA Transfer Time, Transmission Interface Points)</u> on a Scottish Transmission System to be responsible for the co-ordination of Safety Precautions at each Connection Point <u>(or in the case of OTSUA operational prior to the OTSUA Transfer Time, Transmission Interface Points)</u> when work (which includes testing) is to be carried out on a System which necessitates the provision of Safety Precautions on HV Apparatus (as defined in OC8A.1.6.2 and OC8B.1.7.2), pursuant to OC8. |
| Scottish User                                     | A User in Scotland or any Offshore User who owns or operates Plant and/or Apparatus connected <u>(or which will at the OTSUA Transfer Time be connected)</u> to a Scottish Offshore Transmission System   |
| Transmission DC Converter                         | Any Transmission Licensee Apparatus <u>(or OTSUA that will become Transmission Licensee Apparatus at the OTSUA Transfer Time)</u> used to convert alternating current electricity to direct current electricity, or vice versa. A Transmission Network DC Converter is a standalone operative configuration at a single site comprising one or more converter bridges, together with one or more converter transformers, converter control equipment, essential protective and switching devices and auxiliaries, if any, used for conversion.  |
| User System                                       | Any system owned or operated by a User comprising:- <ul style="list-style-type: none"> <li>(a) <b>Generating Units</b>; and/or</li> <li>(b) Systems consisting (wholly or mainly) of electric lines used for the distribution of electricity from <b>Grid Supply Points</b> or <b>Generating Units</b> or other entry points to the point of delivery to <b>Customers</b>, or other <b>Users</b>;</li> </ul> <p>and Plant and/or Apparatus <u>(including prior to the OTSUA Transfer Time, any OTSUA)</u> connecting:-</p> <ul style="list-style-type: none"> <li>(c) The system as described above; or</li> <li>(d) <b>Non-Embedded Customers</b> equipment;</li> </ul> <p>to the <b>National Electricity Transmission System</b> or to the relevant other <b>User System</b>, as the case may be.</p>   |

The **User System** includes any **Remote Transmission Assets** operated by such **User** or other person and any **Plant** and/or **Apparatus** and meters owned or operated by the **User** or other person in connection with the distribution of electricity but does not include any part of the **National Electricity Transmission System**.

## Grid Code Planning Code

The following edits shall be made to PC.4.4.1

PC.4.4            Offer of Terms for Connection

PC.4.4.1        CUSC Contract – Data Requirements/Offer Timing

The completed application form for a **CUSC Contract** to be submitted by a **User** when making an application for a **CUSC Contract** will include:

- (a) a description of the **Plant** and/or **Apparatus** (excluding **OTSDUW Plant and Apparatus**) to be connected to the **National Electricity Transmission System** or of the **Modification** relating to the **User's Plant** and/or **Apparatus** (and prior to the OTSUA Transfer Time, any OTSUA) already connected to the **National Electricity Transmission System** or, as the case may be, of the proposed new connection or **Modification** to the connection within the **User System** of the **User**, each of which shall be termed a "**User Development**" in the **PC**;
- (b) the relevant **Standard Planning Data** as listed in Part 1 of the Appendix (except in respect of any **OTSUA**); and
- (c) the desired **Completion Date** of the proposed **User Development**.
- (d) the desired **Connection Entry Capacity** and **Transmission Entry Capacity**.

The completed application form for a **CUSC Contract** will be sent to **NET** as more particularly provided in the application form.

# CONNECTION CONDITIONS

(CC)

## CONTENTS

(This contents page does not form part of the Grid Code)

| <u>Paragraph No/Title</u>  | <u>Page Number</u> |
|--|--------------------|
| CC.1 INTRODUCTION.....   | 2                  |
| CC.2 OBJECTIVE.....  | 2                  |
| CC.3 SCOPE .....   | 2                  |
| CC.4 PROCEDURE .....   | 4                  |
| CC.5 CONNECTION .....  | 4                  |
| CC.6 TECHNICAL, DESIGN AND OPERATIONAL CRITERIA.....   | 6                  |
| CC.7 SITE RELATED CONDITIONS .....   | 38                 |
| CC.8 ANCILLARY SERVICES .....  | <u>4445</u>        |
| APPENDIX 1 - SITE RESPONSIBILITY SCHEDULES .....   | <u>4647</u>        |
| PROFORMA FOR SITE RESPONSIBILITY SCHEDULE .....  | <u>4951</u>        |
| APPENDIX 2 - OPERATION DIAGRAMS.....   | <u>5355</u>        |
| PART 1A - PROCEDURES RELATING TO OPERATION DIAGRAMS .....  | <u>5355</u>        |
| PART 1B - PROCEDURES RELATING TO GAS ZONE DIAGRAMS .....   | <u>5658</u>        |
| PART 2 - NON-EXHAUSTIVE LIST OF APPARATUS TO BE INCLUDED ON<br>OPERATION DIAGRAMS.....   | <u>5759</u>        |
| APPENDIX 3 - MINIMUM FREQUENCY RESPONSE REQUIREMENT PROFILE AND<br>OPERATING RANGE FOR NEW POWER STATIONS AND DC CONVERTER<br>STATIONS.....  | <u>5961</u>        |
| APPENDIX 4 - FAULT RIDE THROUGH REQUIREMENTS.....  | <u>6466</u>        |
| APPENDIX 4A .....  | <u>6466</u>        |
| APPENDIX 4B .....  | <u>6769</u>        |
| APPENDIX 5 - TECHNICAL REQUIREMENTS LOW FREQUENCY RELAYS FOR<br>THE AUTOMATIC DISCONNECTION OF SUPPLIES AT LOW FREQUENCY .....   | <u>7473</u>        |
| APPENDIX 6 - PERFORMANCE REQUIREMENTS FOR CONTINUOUSLY ACTING<br>AUTOMATIC EXCITATION CONTROL SYSTEMS FOR ONSHORE SYNCHRONOUS<br>GENERATING UNITS .....  | <u>7375</u>        |
| APPENDIX 7 - PERFORMANCE REQUIREMENTS FOR CONTINUOUSLY ACTING<br>AUTOMATIC VOLTAGE CONTROL SYSTEMS FOR ONSHORE NON-<br>SYNCHRONOUS GENERATING UNITS, ONSHORE DC CONVERTERS, ONSHORE<br>POWER PARK MODULES AND OTSDUW PLANT AND APPARATUS AT THE<br>INTERFACE POINT ..... | <u>7779</u>        |



## CC.1 INTRODUCTION

- CC.1.1 The **Connection Conditions** ("**CC**") specify both:
- (a) the minimum technical, design and operational criteria which must be complied with by:
    - (i) any **User** connected to or seeking connection with the **National Electricity Transmission System**, or
    - (ii) **Generators** (other than in respect of **Small Power Stations**) or **DC Converter Station** owners connected to or seeking connection to a **User's System** which is located in **Great Britain** or **Offshore**, and
  - (b) the minimum technical, design and operational criteria with which **NGET** will comply in relation to the part of the **National Electricity Transmission System** at the **Connection Site** with **Users**. In the case of any **OTSDUW Plant and Apparatus**, the **CC** also specify the minimum technical, design and operational criteria which must be complied with by the **User** when undertaking **OTSDUW**.

## CC.2 OBJECTIVE

- CC.2.1 The objective of the **CC** is to ensure that by specifying minimum technical, design and operational criteria the basic rules for connection to the **National Electricity Transmission System** and (for certain **Users**) to a **User's System** are similar for all **Users** of an equivalent category and will enable **NGET** to comply with its statutory and **Transmission Licence** obligations.
- CC.2.2 In the case of any **OTSDUW** the objective of the **CC** is to ensure that by specifying the minimum technical, design and operational criteria the basic rules relating to an **Offshore Transmission System** designed and constructed by an **Offshore Transmission Licensee** and designed and/or constructed by a **User** under the **OTSDUW Arrangements** are equivalent.
- CC.2.3 Provisions of the **CC** which apply in relation to **OTSDUW** and **OTSUA**, and/or a **Transmission Interface Site**, shall (in any particular case) apply up to the **OTSUA Transfer Time**, whereupon such provisions shall (without prejudice to any prior non-compliance) cease to apply, without prejudice to the continuing application of provisions of the **CC** applying in relation to the relevant **Offshore Transmission System** and/or **Connection Site**. It is the case therefore that in cases where the **OTSUA** become operational prior to the **OTSUA Transfer Time** that a **Generator** is required to comply with this **CC** both as it applies to its **Plant and Apparatus** at a **Connection Site/Connection Point** and the **OTSUA** at the **Transmission Interface Site/Transmission Interface Point** until the **OTSUA Transfer Time** and this **CC** shall be construed accordingly.
- CC.2.4 In relation to **OTSDUW**, provisions otherwise to be contained in a **Bilateral Agreement** may be contained in the **Construction Agreement**, and accordingly a reference in the **CC** to a relevant **Bilateral Agreement** includes the relevant **Construction Agreement**.

## CC.3 SCOPE

- CC.3.1 The **CC** applies to **NGET** and to **Users**, which in the **CC** means:
- (a) **Generators** (other than those which only have **Embedded Small Power Stations**), including those undertaking **OTSDUW**;
  - (b) **Network Operators**;
  - (c) **Non-Embedded Customers**;

- (d) **DC Converter Station** owners; and
- (e) **BM Participants** and **Externally Interconnected System Operators** in respect of CC.6.5 only.

CC.3.2 The above categories of **User** will become bound by the **CC** prior to them generating, distributing, supplying or consuming, as the case may be, and references to the various categories should, therefore, be taken as referring to them in that prospective role as well as to **Users** actually connected.

CC.3.3 **Embedded Medium Power Stations** not subject to a **Bilateral Agreement** and **Embedded DC Converter Stations** not subject to a **Bilateral Agreement** Provisions.

The following provisions apply in respect of **Embedded Medium Power Stations** not subject to a **Bilateral Agreement** and **Embedded DC Converter Stations** not subject to a **Bilateral Agreement**.

CC.3.3.1 The obligations within the **CC** that are expressed to be applicable to **Generators** in respect of **Embedded Medium Power Stations** not subject to a **Bilateral Agreement** and **DC Converter Station** Owners in respect of **Embedded DC Converter Stations** not subject to a **Bilateral Agreement** (where the obligations are in each case listed in CC.3.3.2) shall be read and construed as obligations that the **Network Operator** within whose **System** any such **Medium Power Station** or **DC Converter Station** is **Embedded** must ensure are performed and discharged by the **Generator** or the **DC Converter Station** owner. **Embedded Medium Power Stations** not subject to a **Bilateral Agreement** and **Embedded DC Converter Stations** not subject to a **Bilateral Agreement** which are located **Offshore** and which are connected to an **Onshore User System** will be required to meet the applicable requirements of the Grid Code as though they are an **Onshore Generator** or **Onshore DC Converter Station Owner** connected to an **Onshore User System Entry Point**.

CC.3.3.2 The **Network Operator** within whose **System** a **Medium Power Station** not subject to a **Bilateral Agreement** is **Embedded** or a **DC Converter Station** not subject to a **Bilateral Agreement** is **Embedded** must ensure that the following obligations in the **CC** are performed and discharged by the **Generator** in respect of each such **Embedded Medium Power Station** or the **DC Converter Station** owner in the case of an **Embedded DC Converter Station**:

CC.5.1

CC.5.2.2

CC.5.3

CC.6.1.3

CC.6.1.5 (b)

CC.6.3.2, CC.6.3.3, CC.6.3.4, CC.6.3.6, CC.6.3.7, CC.6.3.8, CC.6.3.9, CC.6.3.10, CC.6.3.12, CC.6.3.13, CC.6.3.15, CC.6.3.16

CC.6.4.4

CC.6.5.6 (where required by CC.6.4.4)

In respect of CC.6.2.2.2, CC.6.2.2.3, CC.6.2.2.5, CC.6.1.5(a), CC.6.1.5(b) and CC.6.3.11 equivalent provisions as co-ordinated and agreed with the **Network Operator** and **Generator** or **DC Converter Station** owner may be required. Details of any such requirements will be notified to the **Network Operator** in accordance with CC.3.5.

- CC.3.3.3 In the case of **Embedded Medium Power Stations** not subject to a **Bilateral Agreement** and **Embedded DC Converter Stations** not subject to a **Bilateral Agreement** the requirements in:
- CC.6.1.6
  - CC.6.3.8
  - CC.6.3.12
  - CC.6.3.15
  - CC.6.3.16

that would otherwise have been specified in a **Bilateral Agreement** will be notified to the relevant **Network Operator** in writing in accordance with the provisions of the **CUSC** and the **Network Operator** must ensure such requirements are performed and discharged by the **Generator** or the **DC Converter Station** owner.

- CC.3.4 In the case of **Offshore Embedded Power Stations** connected to an **Offshore User's System** which directly connects to an **Offshore Transmission System**, any additional requirements in respect of such **Offshore Embedded Power Stations** may be specified in the relevant **Bilateral Agreement** with the **Network Operator** or in any **Bilateral Agreement** between **NGET** and such **Offshore Embedded Power Station**.
- CC.3.5 In the case of a **Generator** undertaking **OTSDUW** connecting to an **Onshore Network Operator's System**, any additional requirements in respect of such **OTSDUW Plant and Apparatus** will be specified in the relevant **Bilateral Agreement** with the **Generator**. For the avoidance of doubt, requirements applicable to **Generators** undertaking **OTSDUW** and connecting to a **Network Operator's User System**, shall be consistent with those applicable requirements of **Generators** undertaking **OTSDUW** and connecting to a **Transmission Interface Point**.

CC.4 PROCEDURE

- CC.4.1 The **CUSC** contains certain provisions relating to the procedure for connection to the **National Electricity Transmission System** or, in the case of **Embedded Power Stations** or **Embedded DC Converter Stations**, becoming operational and includes provisions relating to certain conditions to be complied with by **Users** prior to and during the course of **NGET** notifying the **User** that it has the right to become operational. The procedure for a **User** to become connected is set out in the **Compliance Processes**.

CC.5 CONNECTION

- CC.5.1 The provisions relating to connecting to the **National Electricity Transmission System** (or to a **User's System** in the case of a connection of an **Embedded Large Power Station** or **Embedded Medium Power Station** or **Embedded DC Converter Station**) are contained in:
- (a) the **CUSC** and/or **CUSC Contract** (or in the relevant application form or offer for a **CUSC Contract**);
  - (b) or, in the case of an **Embedded Development**, the relevant **Distribution Code** and/or the **Embedded Development Agreement** for the connection (or in the relevant application form or offer for an **Embedded Development Agreement**),

and include provisions relating to both the submission of information and reports relating to compliance with the relevant **Connection Conditions** for that **User**, **Safety Rules**, commissioning programmes, **Operation Diagrams** and approval to connect (and their equivalents in the case of **Embedded Medium Power Stations** not subject to a **Bilateral Agreement** or **Embedded DC Converter Stations** not subject to a **Bilateral Agreement**). References in the **CC** to the "**Bilateral Agreement**" and/or "**Construction Agreement**" and/or "**Embedded Development Agreement**" shall be deemed to include references to the application form or offer therefor.

CC.5.2 Items For Submission

CC.5.2.1 Prior to the **Completion Date** (or, where the Generator is undertaking OTSDUW, any later date specified) under the **Bilateral Agreement** and/or **Construction Agreement**, the following is submitted pursuant to the terms of the **Bilateral Agreement** and/or **Construction Agreement**:

- (a) updated **Planning Code** data (both **Standard Planning Data** and **Detailed Planning Data**), with any estimated values assumed for planning purposes confirmed or, where practical, replaced by validated actual values and by updated estimates for the future and by updated forecasts for **Forecast Data** items such as **Demand**, pursuant to the requirements of the **Planning Code**;
- (b) details of the **Protection** arrangements and settings referred to in CC.6;
- (c) copies of all **Safety Rules** and **Local Safety Instructions** applicable at **Users' Sites** which will be used at the **NGET/User** interface (which, for the purpose of **OC8**, must be to **NGET's** satisfaction regarding the procedures for **Isolation** and **Earthing**. For **User Sites** in Scotland and **Offshore NGET** will consult the **Relevant Transmission Licensee** when determining whether the procedures for **Isolation** and **Earthing** are satisfactory);
- (d) information to enable **NGET** to prepare **Site Responsibility Schedules** on the basis of the provisions set out in Appendix 1;
- (e) an **Operation Diagram** for all **HV Apparatus** on the **User** side of the **Connection Point** as described in CC.7;
- (f) the proposed name of the **User Site** (which shall not be the same as, or confusingly similar to, the name of any **Transmission Site** or of any other **User Site**);
- (g) written confirmation that **Safety Co-ordinators** acting on behalf of the **User** are authorised and competent pursuant to the requirements of **OC8**;
- (h) **RISSP** prefixes pursuant to the requirements of **OC8**. **NGET** is required to circulate prefixes utilising a proforma in accordance with **OC8**;
- (i) a list of the telephone numbers for **Joint System Incidents** at which senior management representatives nominated for the purpose can be contacted and confirmation that they are fully authorised to make binding decisions on behalf of the **User**, pursuant to **OC9**;
- (j) a list of managers who have been duly authorised to sign **Site Responsibility Schedules** on behalf of the **User**;
- (k) information to enable **NGET** to prepare **Site Common Drawings** as described in CC.7;
- (l) a list of the telephone numbers for the **Users** facsimile machines referred to in CC.6.5.9; and

- (m) for **Sites** in Scotland and **Offshore** a list of persons appointed by the **User** to undertake operational duties on the **User's System** (including any **OTSDUW** prior to the **OTSUA Transfer Time**) and to issue and receive operational messages and instructions in relation to the **User's System** (including any **OTSDUW** prior to the **OTSUA Transfer Time**); and an appointed person or persons responsible for the maintenance and testing of **User's Plant** and **Apparatus**.

CC.5.2.2 Prior to the **Completion Date** the following must be submitted to **NGET** by the **Network Operator** in respect of an **Embedded Development**:

- (a) updated **Planning Code** data (both **Standard Planning Data** and **Detailed Planning Data**), with any estimated values assumed for planning purposes confirmed or, where practical, replaced by validated actual values and by updated estimates for the future and by updated forecasts for **Forecast Data** items such as **Demand**, pursuant to the requirements of the **Planning Code**;
- (b) details of the **Protection** arrangements and settings referred to in CC.6;
- (c) the proposed name of the **Embedded Medium Power Station** or **Embedded DC Converter Station Site** (which shall be agreed with **NGET** unless it is the same as, or confusingly similar to, the name of other **Transmission Site** or **User Site**);

CC.5.2.3 Prior to the **Completion Date** contained within an **Offshore Transmission Distribution Connection Agreement** the following must be submitted to **NGET** by the **Network Operator** in respect of a proposed new **Interface Point** within its **User System**:

- (a) updated **Planning Code** data (both **Standard Planning Data** and **Detailed Planning Data**), with any estimated values assumed for planning purposes confirmed or, where practical, replaced by validated actual values and by updated estimates for the future and by updated forecasts for **Forecast Data** items such as **Demand**, pursuant to the requirements of the **Planning Code**;
- (b) details of the **Protection** arrangements and settings referred to in CC.6;
- (c) the proposed name of the **Interface Point** (which shall not be the same as, or confusingly similar to, the name of any **Transmission Site** or of any other **User Site**);

CC.5.2.4 In the case of **OTSDUW Plant and Apparatus** (in addition to items under CC.5.2.1 in respect of the **Connection Site**), prior to the **Completion Date** (or any later date specified) under the **Construction Agreement** the following must be submitted to **NGET** by the **User** in respect of the proposed new **Connection Point** and **Interface Point**:

- (a) updated **Planning Code** data (**Standard Planning Data**, **Detailed Planning Data** and **OTSDUW Data and Information**), with any estimated values assumed for planning purposes confirmed or, where practical, replaced by validated actual values and by updated estimates for the future and by updated forecasts for **Forecast Data** items such as **Demand**, pursuant to the requirements of the **Planning Code**;
- (b) details of the **Protection** arrangements and settings referred to in CC.6;
- (c) information to enable preparation of the **Site Responsibility Schedules** at the **Transmission Interface Site** on the basis of the provisions set out in Appendix 1.
- (d) the proposed name of the **Interface Point** (which shall not be the same as, or confusingly similar to, the name of any **Transmission Site** or of any other **User Site**);

- CC.5.3 (a) Of the items CC.5.2.1 (c), (e), (g), (h), (k) and (m) need not be supplied in respect of **Embedded Power Stations** or **Embedded DC Converter Stations**,
- (b) item CC.5.2.1(i) need not be supplied in respect of **Embedded Small Power Stations** and **Embedded Medium Power Stations** or **Embedded DC Converter Stations** with a **Registered Capacity** of less than 100MW, and
- (c) items CC.5.2.1(d) and (j) are only needed in the case where the **Embedded Power Station** or the **Embedded DC Converter Station** is within a **Connection Site** with another **User**.

CC.5.4 In addition, at the time the information is given under CC.5.2(g), **NGET** will provide written confirmation to the **User** that the **Safety Co-ordinators** acting on behalf of **NGET** are authorised and competent pursuant to the requirements of **OC8**.

CC.6 TECHNICAL, DESIGN AND OPERATIONAL CRITERIA

CC.6.1 National Electricity Transmission System Performance Characteristics

CC.6.1.1 **NGET** shall ensure that, subject as provided in the **Grid Code**, the **National Electricity Transmission System** complies with the following technical, design and operational criteria in relation to the part of the **National Electricity Transmission System** at the **Connection Site** with a **User** and in the case of **OTSDUW Plant and Apparatus**, a **Transmission Interface Point** (unless otherwise specified in CC.6) although in relation to operational criteria **NGET** may be unable (and will not be required) to comply with this obligation to the extent that there are insufficient **Power Stations** or **User Systems** are not available or **Users** do not comply with **NGET's** instructions or otherwise do not comply with the **Grid Code** and each **User** shall ensure that its **Plant** and **Apparatus** complies with the criteria set out in CC.6.1.5.

#### Grid Frequency Variations

CC.6.1.2 The **Frequency** of the **National Electricity Transmission System** shall be nominally 50Hz and shall be controlled within the limits of 49.5 - 50.5Hz unless exceptional circumstances prevail.

CC.6.1.3 The **System Frequency** could rise to 52Hz or fall to 47Hz in exceptional circumstances. Design of **User's Plant and Apparatus** and **OTSDUW Plant and Apparatus** must enable operation of that **Plant and Apparatus** within that range in accordance with the following:

| <u>Frequency Range</u> | <u>Requirement</u>   |
|------------------------|--|
| 51.5Hz - 52Hz          | Operation for a period of at least 15 minutes is required each time the Frequency is above 51.5Hz. |
| 51Hz - 51.5Hz          | Operation for a period of at least 90 minutes is required each time the Frequency is above 51Hz.   |
| 49.0Hz - 51Hz          | Continuous operation is required   |
| 47.5Hz - 49.0Hz        | Operation for a period of at least 90 minutes is required each time the Frequency is below 49.0Hz. |
| 47Hz - 47.5Hz          | Operation for a period of at least 20 seconds is required each time the Frequency is below 47.5Hz. |

For the avoidance of doubt, disconnection, by frequency or speed based relays is not permitted within the frequency range 47.5Hz to 51.5Hz, unless agreed with **NGET** in accordance with CC.6.3.12.

#### Grid Voltage Variations

CC.6.1.4 Subject as provided below, the voltage on the 400kV part of the **National Electricity Transmission System** at each **Connection Site** with a **User** (and in the case of **OTSDUW Plant and Apparatus**, a **Transmission Interface Point**) will normally remain within  $\pm 5\%$  of the nominal value unless abnormal conditions prevail. The minimum voltage is  $-10\%$  and the maximum voltage is  $+10\%$  unless abnormal conditions prevail, but voltages between  $+5\%$  and  $+10\%$  will not last longer than 15 minutes unless abnormal conditions prevail. Voltages on the 275kV and 132kV parts of the **National Electricity Transmission System** at each **Connection Site** with a **User** (and in the case of **OTSDUW Plant and Apparatus**, a **Transmission Interface Point**) will normally remain within the limits  $\pm 10\%$  of the nominal value unless abnormal conditions prevail. At nominal **System** voltages below 132kV the voltage of the **National Electricity Transmission System** at each **Connection Site** with a **User** (and in the case of **OTSDUW Plant and Apparatus**, a **Transmission Interface Point**) will normally remain within the limits  $\pm 6\%$  of the nominal value unless abnormal conditions prevail. Under fault conditions, voltage may collapse transiently to zero at the point of fault until the fault is cleared. The normal operating ranges of the **National Electricity Transmission System** are summarised below:

| <u>National Electricity Transmission System Nominal Voltage</u> | <u>Normal Operating Range</u> |
|---|-------------------------------|
| 400kV   | 400kV $\pm 5\%$               |
| 275kV   | 275kV $\pm 10\%$              |
| 132kV   | 132kV $\pm 10\%$              |

**NGET** and a **User** may agree greater or lesser variations in voltage to those set out above in relation to a particular **Connection Site**, and insofar as a greater or lesser variation is agreed, the relevant figure set out above shall, in relation to that **User** at the particular **Connection Site**, be replaced by the figure agreed.



### Voltage Waveform Quality

CC.6.1.5

All **Plant** and **Apparatus** connected to the **National Electricity Transmission System**, and that part of the **National Electricity Transmission System** at each **Connection Site** or, in the case of **OTSDUW Plant and Apparatus**, at each **Interface Point**, should be capable of withstanding the following distortions of the voltage waveform in respect of harmonic content and phase unbalance:

(a) Harmonic Content

The **Electromagnetic Compatibility Levels** for harmonic distortion on the **Onshore Transmission System** from all sources under both **Planned Outage** and fault outage conditions, (unless abnormal conditions prevail) shall comply with the levels shown in the tables of Appendix A of **Engineering Recommendation G5/4**. The **Electromagnetic Compatibility Levels** for harmonic distortion on an **Offshore Transmission System** will be defined in relevant **Bilateral Agreements**.

**Engineering Recommendation G5/4** contains planning criteria which **NGET** will apply to the connection of non-linear **Load** to the **National Electricity Transmission System**, which may result in harmonic emission limits being specified for these **Loads** in the relevant **Bilateral Agreement**. The application of the planning criteria will take into account the position of existing and prospective **Users' Plant and Apparatus** (and **OTSDUW Plant and Apparatus**) in relation to harmonic emissions. **Users** must ensure that connection of distorting loads to their **User Systems** do not cause any harmonic emission limits specified in the **Bilateral Agreement**, or where no such limits are specified, the relevant planning levels specified in **Engineering Recommendation G5/4** to be exceeded.

(b) Phase Unbalance

Under **Planned Outage** conditions, the maximum **Phase (Voltage) Unbalance** on the **National Electricity Transmission System** should remain, in England and Wales, below 1%, and in Scotland, below 2%, unless abnormal conditions prevail and **Offshore** (or in the case of **OTSDUW, OTSDUW Plant and Apparatus**) will be defined in relevant **Bilateral Agreements**.

CC.6.1.6

In England and Wales, under the **Planned Outage** conditions stated in CC.6.1.5(b) infrequent short duration peaks with a maximum value of 2% are permitted for **Phase (Voltage) Unbalance**, subject to the prior agreement of **NGET** under the **Bilateral Agreement** and in relation to **OTSDUW**, the **Construction Agreement**. **NGET** will only agree following a specific assessment of the impact of these levels on **Transmission Apparatus** and other **Users Apparatus** with which it is satisfied.

### Voltage Fluctuations

CC.6.1.7

Voltage fluctuations at a **Point of Common Coupling** with a fluctuating **Load** directly connected to the **Onshore Transmission System** shall not exceed:

- (a) In England and Wales, 1% of the voltage level for step changes which may occur repetitively. Any large voltage excursions other than step changes may be allowed up to a level of 3% provided that this does not constitute a risk to the **National Electricity Transmission System** or, in **NGET's** view, to the **System** of any **User**. In Scotland, the limits for voltage level step changes are as set out in **Engineering Recommendation P28**.

- (b) For voltages above 132kV, **Flicker Severity (Short Term)** of 0.8 Unit and a **Flicker Severity (Long Term)** of 0.6 Unit, for voltages 132kV and below, **Flicker Severity (Short Term)** of 1.0 Unit and a **Flicker Severity (Long Term)** of 0.8 Unit, as set out in **Engineering Recommendation P28** as current at the **Transfer Date**.

CC.6.1.8

Voltage fluctuations at a **Point of Common Coupling** with a fluctuating **Load** directly connected to an **Offshore Transmission System** (or in the case of **OTSDUW, OTSDUW Plant and Apparatus**) shall not exceed the limits set out in the **Bilateral Agreement**.

CC.6.2 Plant and Apparatus relating to Connection Site and Interface Point

The following requirements apply to **Plant** and **Apparatus** relating to the **Connection Point**, and **OTSDUW Plant and Apparatus** relating to the **Interface Point** (until the **OTSUA Transfer Time**) and **Connection Point** which (except as otherwise provided in the relevant paragraph) each **User** must ensure are complied with in relation to its **Plant** and **Apparatus** and which in the case of CC.6.2.2.2, CC.6.2.3.1.1 and CC.6.2.1.1(b) only, **NGET** must ensure are complied with in relation to **Transmission Plant** and **Apparatus**, as provided in those paragraphs.

CC.6.2.1 General Requirements

CC.6.2.1.1 (a) The design of connections between the **National Electricity Transmission System** and:

- (i) any **Generating Unit** (other than a **CCGT Unit** or **Power Park Unit**) **DC Converter, Power Park Module** or **CCGT Module**, or
  - (ii) any **Network Operator's User System**, or
  - (iii) **Non-Embedded Customers** equipment;
- will be consistent with the **Licence Standards**.

In the case of **OTSDUW**, the design of the **OTSUA's** connections at the **Interface Point** and **Connection Point** will be consistent with **Licence Standards**.

- (b) The **National Electricity Transmission System** (and any **OTSDUW Plant and Apparatus**) at nominal **System** voltages of 132kV and above is/shall be designed to be earthed with an **Earth Fault Factor** of, in England and Wales or **Offshore**, below 1.4 and in Scotland, below 1.5. Under fault conditions the rated **Frequency** component of voltage could fall transiently to zero on one or more phases or, in England and Wales, rise to 140% phase-to-earth voltage, or in Scotland, rise to 150% phase-to-earth voltage. The voltage rise would last only for the time that the fault conditions exist. The fault conditions referred to here are those existing when the type of fault is single or two phase-to-earth.
- (c) For connections to the **National Electricity Transmission System** at nominal **System** voltages of below 132kV the earthing requirements and voltage rise conditions will be advised by **NGET** as soon as practicable prior to connection and in the case of **OTSDUW Plant and Apparatus** shall be advised to **NGET** by the **User**.

CC.6.2.1.2 Substation Plant and Apparatus

- (a) The following provisions shall apply to all **Plant** and **Apparatus** which is connected at the voltage of the **Connection Point** (and **OTSDUW Plant and Apparatus** at the **Interface Point**) and which is contained in equipment bays that are within the **Transmission** busbar **Protection** zone at the **Connection Point**. This includes circuit breakers, switch disconnectors, disconnectors, **Earthing Devices**, power transformers, voltage transformers, reactors, current transformers, surge arresters, bushings, neutral equipment, capacitors, line traps, coupling devices, external insulation and insulation co-ordination devices. Where necessary, this is as more precisely defined in the **Bilateral Agreement**.

- (i) Plant and/or Apparatus prior to 1st January 1999

Each item of such **Plant** and/or **Apparatus** which at 1st January 1999 is either :

installed; or

owned (but is either in storage, maintenance or awaiting installation); or

ordered;

and is the subject of a **Bilateral Agreement** with regard to the purpose for which it is in use or intended to be in use, shall comply with the relevant standards/specifications applicable at the time that the **Plant** and/or **Apparatus** was designed (rather than commissioned) and any further requirements as specified in the **Bilateral Agreement**.

- (ii) Plant and/or Apparatus post 1st January 1999 for a new Connection Point (including OTSDUW Plant and Apparatus at the Interface Point)

Each item of such **Plant** and/or **Apparatus** installed in relation to a new **Connection Point** (or **OTSDUW Plant and Apparatus at the Interface Point**) after 1st January 1999 shall comply with the relevant **Technical Specifications** and any further requirements identified by **NGET**, acting reasonably, to reflect the options to be followed within the **Technical Specifications** and/or to complement if necessary the **Technical Specifications** so as to enable **NGET** to comply with its obligations in relation to the **National Electricity Transmission System** or, in Scotland or **Offshore**, the **Relevant Transmission Licensee** to comply with its obligations in relation to its **Transmission System**. This information, including the application dates of the relevant **Technical Specifications**, will be as specified in the **Bilateral Agreement**.

- (iii) New Plant and/or Apparatus post 1st January 1999 for an existing Connection Point (including OTSDUW Plant and Apparatus at the Interface Point)

Each new additional and/or replacement item of such **Plant** and/or **Apparatus** installed in relation to a change to an existing **Connection Point** (or **OTSDUW Plant and Apparatus at the Interface Point** and **Connection Point**) after 1st January 1999 shall comply with the standards/specifications applicable when the change was designed, or such other standards/specifications as necessary to ensure that the item of **Plant** and/or **Apparatus** is reasonably fit for its intended purpose having due regard to the obligations of **NGET**, the relevant **User** and, in Scotland, or **Offshore**, also the **Relevant Transmission Licensee** under their respective **Licences**. Where appropriate this information, including the application dates of the relevant standards/specifications, will be as specified in the varied **Bilateral Agreement**.

- (iv) Used Plant and/or Apparatus being moved, re-used or modified

If, after its installation, any such item of **Plant** and/or **Apparatus** is subsequently:

moved to a new location; or

used for a different purpose; or

otherwise modified;

then the standards/specifications as described in (i), (ii), or (iii) above as applicable will apply as appropriate to such **Plant** and/or **Apparatus**, which must be reasonably fit for its intended purpose having due regard to the obligations of **NGET**, the relevant **User** and, in Scotland or **Offshore**, also the **Relevant Transmission Licensee** under their respective **Licences**.

- (b) **NGET** shall at all times maintain a list of those **Technical Specifications** and additional requirements which might be applicable under this CC.6.2.1.2 and which may be referenced by **NGET** in the **Bilateral Agreement**. **NGET** shall provide a copy of the list upon request to any **User**. **NGET** shall also provide a copy of the list to any new **User** upon receipt of an application form for a **Bilateral Agreement** for a new **Connection Point**.
- (c) Where the **User** provides **NGET** with information and/or test reports in respect of **Plant** and/or **Apparatus** which the **User** reasonably believes demonstrate the compliance of such items with the provisions of a **Technical Specification** then **NGET** shall promptly and without unreasonable delay give due and proper consideration to such information.
- (d) **Plant** and **Apparatus** shall be designed, manufactured and tested in premises with an accredited certificate in accordance with the quality assurance requirements of the relevant standard in the BS EN ISO 9000 series (or equivalent as reasonably approved by **NGET**) or in respect of test premises which do not include a manufacturing facility premises with an accredited certificate in accordance with BS EN 45001.
- (e) Each connection between a **User** and the **National Electricity Transmission System** must be controlled by a circuit-breaker (or circuit breakers) capable of interrupting the maximum short circuit current at the point of connection. The **Seven Year Statement** gives values of short circuit current and the rating of **Transmission** circuit breakers at existing and committed **Connection Points** for future years.
- (f) Each connection between a **Generator** undertaking **OTSDUW** or an **Onshore Transmission Licensee**, must be controlled by a circuit breaker (or circuit breakers) capable of interrupting the maximum short circuit current at the **Transmission Interface Point**. The **Seven Year Statement** gives values of short circuit current and the rating of **Transmission** circuit breakers at existing and committed **Transmission Interface Points** for future years.

CC.6.2.2 Requirements at Connection Points or, in the case of OTSDUW at Interface Points that relate to Generators or OTSDUW Plant and Apparatus or DC Converter Station owners

CC.6.2.2.1 Not Used.

CC.6.2.2.2 Generating Unit, OTSDUW Plant and Apparatus and Power Station Protection Arrangements

CC.6.2.2.2.1 Minimum Requirements

**Protection** of Generating Units (other than Power Park Units), DC Converters, **OTSDUW Plant and Apparatus** or Power Park Modules and their connections to the **National Electricity Transmission System** must meet the minimum requirements given below. These are necessary to reduce to a practical minimum the impact on the **National Electricity Transmission System** of faults on **OTSDUW Plant and Apparatus** circuits or circuits owned by Generators or DC Converter Station owners.

CC.6.2.2.2.2 Fault Clearance Times

- (a) The fault clearance times for faults on the Generator's or DC Converter Station owner's equipment directly connected to the **National Electricity Transmission System** or **OTSDUW Plant and Apparatus** and for faults on the **National Electricity Transmission System** directly connected to the Generator or DC Converter Station owner's equipment or **OTSDUW Plant and Apparatus**, from fault inception to the circuit breaker arc extinction, shall be set out in accordance with the **Bilateral Agreement**. The times specified in accordance with the **Bilateral Agreement** shall not be faster than:
- (i) 80mS at 400kV
  - (ii) 100mS at 275kV
  - (iii) 120mS at 132kV and below

but this shall not prevent a **User** or **NGET** or a **Generator** in respect of **OTSDUW Plant and Apparatus** having faster fault clearance times.

Slower fault clearance times may be specified in accordance with the **Bilateral Agreement** for faults on the **National Electricity Transmission System**. Slower fault clearance times for faults on the **Generator** or **DC Converter Station** owner's equipment or **OTSDUW Plant and Apparatus** may be agreed in accordance with the terms of the **Bilateral Agreement** but only if **System** requirements, in **NGET's** view, permit. The probability that the fault clearance times stated in accordance with the **Bilateral Agreement** will be exceeded by any given fault, must be less than 2%.

- (b) For the event that the above fault clearance times are not met as a result of failure to operate on the **Main Protection System(s)** provided, the **Generators** or **DC Converter Station** owners or **Generators** in the case of **OTSDUW Plant and Apparatus** shall provide **Back-Up Protection**. **NGET** will also provide **Back-Up Protection** and these **Back-Up Protections** will be co-ordinated so as to provide **Discrimination**.

On a **Generating Unit** (other than **Power Park Units**), **DC Converter** or **Power Park Module** or **OTSDUW Plant and Apparatus** connected to the **National Electricity Transmission System** where only one **Main Protection** is provided to clear faults on the **HV Connections** within the required fault clearance time, the **Back-Up Protection** provided by the **Generators** (including in respect of **OTSDUW Plant and Apparatus**) and **DC Converter Station** owners shall operate to give a fault clearance time of no slower than 300 ms at the minimum infeed for normal operation for faults on the **HV Connections**. On **Generating Units** (other than **Power Park Units**), **DC Converters** or **Power Park Modules** or **OTSDUW Plant and Apparatus** connected to the **National Electricity Transmission System** at 400 kV and 275 kV where two **Main Protections** are provided and on **Generating Units** (other than **Power Park Units**), **DC Converters** or **Power Park Modules** or **OTSDUW Plant and Apparatus** connected to the **National Electricity Transmission System** at 132 kV and below, the **Back-Up Protection** shall operate to give a fault clearance time of no slower than 800 ms in England and Wales or **Offshore** and 300 ms in Scotland at the minimum infeed for normal operation for faults on the **HV Connections**.

**Generators'** (including in respect of **OTSDUW Plant and Apparatus**) and **DC Converter Station** owners' **Back-Up Protection** will also be required to withstand, without tripping, the loading incurred during the clearance of a fault on the **National Electricity Transmission System** by breaker fail **Protection** at 400kV or 275kV or of a fault cleared by **Back-Up Protection** where the **Generator** (including in the case of **OTSDUW Plant and Apparatus**) or **DC Converter** is connected at 132kV and below. This will permit **Discrimination** between **Generator** or **DC Converter Back-Up Protection** and **Back-Up Protection** provided on the **National Electricity Transmission System** and other **Users' Systems**.

- (c) When the **Generating Unit** (other than **Power Park Units**), or the **DC Converter** or **Power Park Module** or **OTSDUW Plant and Apparatus** is connected to the **National Electricity Transmission System** at 400kV or 275kV, and in Scotland and **Offshore** also at 132kV, and a circuit breaker is provided by the **Generator** (including in respect of **OTSDUW Plant and Apparatus**) or the **DC Converter Station** owner, or **NGET**, as the case may be, to interrupt fault current interchange with the **National Electricity Transmission System**, or **Generator's System**, or **DC Converter Station** owner's **System**, as the case may be, circuit breaker fail **Protection** shall be provided by the **Generator** (including in respect of **OTSDUW Plant and Apparatus**) or **DC Converter Station** owner, or **NGET**, as the case may be, on this circuit breaker. In the event, following operation of a **Protection** system, of a failure to interrupt fault current by these circuit-breakers within the **Fault Current Interruption Time**, the circuit breaker fail **Protection** is required to initiate tripping of all the necessary electrically adjacent circuit-breakers so as to interrupt the fault current within the next 200 ms.
- (d) The target performance for the **System Fault Dependability Index** shall be not less than 99%. This is a measure of the ability of **Protection** to initiate successful tripping of circuit breakers which are associated with the faulty item of **Apparatus**.

CC.6.2.2.3 Equipment to be provided

CC.6.2.2.3.1 Protection of Interconnecting Connections

The requirements for the provision of **Protection** equipment for interconnecting connections will be specified in the **Bilateral Agreement**. In this **CC** the term "interconnecting connections" means the primary conductors from the current transformer accommodation on the circuit side of the circuit breaker to the **Connection Point** or the primary conductors from the current transformer accommodation on the circuit side of the **OTSDUW Plant and Apparatus** of the circuit breaker to the **Transmission Interface Point**.

CC.6.2.2.3.2 Circuit-breaker fail Protection

The **Generator** or **DC Converter Station** owner will install circuit breaker fail **Protection** equipment in accordance with the requirements of the **Bilateral Agreement**. The **Generator** or **DC Converter Station** owner will also provide a back-trip signal in the event of loss of air from its pressurised head circuit breakers, during the **Generating Unit** (other than a **CCGT Unit** or **Power Park Unit**) or **CCGT Module** or **DC Converter** or **Power Park Module** run-up sequence, where these circuit breakers are installed.

CC.6.2.2.3.3 Loss of Excitation

The **Generator** must provide **Protection** to detect loss of excitation on a **Generating Unit** and initiate a **Generating Unit** trip.

CC.6.2.2.3.4 Pole-Slipping Protection

Where, in **NGET's** reasonable opinion, **System** requirements dictate, **NGET** will specify in the **Bilateral Agreement** a requirement for **Generators** to fit pole-slipping **Protection** on their **Generating Units**.

CC.6.2.2.3.5 Signals for Tariff Metering

**Generators** and **DC Converter Station** owners will install current and voltage transformers supplying all tariff meters at a voltage to be specified in, and in accordance with, the **Bilateral Agreement**.

CC.6.2.2.4 Work on Protection Equipment

No busbar **Protection**, mesh corner **Protection**, circuit-breaker fail **Protection** relays, AC or DC wiring (other than power supplies or DC tripping associated with the **Generating Unit**, **DC Converter** or **Power Park Module** itself) may be worked upon or altered by the **Generator** or **DC Converter Station** owner personnel in the absence of a representative of **NGET** or in Scotland or **Offshore**, a representative of **NGET**, or written authority from **NGET** to perform such work or alterations in the absence of a representative of **NGET**.

CC.6.2.2.5 Relay Settings

**Protection** and relay settings will be co-ordinated (both on connection and subsequently) across the **Connection Point** in accordance with the **Bilateral Agreement** and in relation to **OTSDUW Plant and Apparatus**, across the **Interface Point** in accordance with the **Bilateral Agreement** to ensure effective disconnection of faulty **Apparatus**.

CC.6.2.3 Requirements at Connection Points relating to Network Operators and Non-Embedded Customers

CC.6.2.3.1 Protection Arrangements for Network Operators and Non-Embedded Customers

CC.6.2.3.1.1 **Protection of Network Operator and Non-Embedded Customers User Systems** directly supplied from the **National Electricity Transmission System**, must meet the minimum requirements referred to below:

Fault Clearance Times

(a) The fault clearance times for faults on **Network Operator** and **Non-Embedded Customer** equipment directly connected to the **National Electricity Transmission System**, and for faults on the **National Electricity Transmission System** directly connected to the **Network Operator's** or **Non-Embedded Customer's** equipment, from fault inception to the circuit breaker arc extinction, shall be set out in accordance with each **Bilateral Agreement**. The times specified in accordance with the **Bilateral Agreement** shall not be faster than:

- (i) 80mS at 400kV
- (ii) 100mS at 275kV
- (iii) 120mS at 132kV and below

but this shall not prevent a **User** or **NGET** having a faster fault clearance time.

Slower fault clearance times may be specified in accordance with the **Bilateral Agreement** for faults on the **National Electricity Transmission System**. Slower fault clearance times for faults on the **Network Operator** and **Non-Embedded Customers** equipment may be agreed in accordance with the terms of the **Bilateral Agreement** but only if **System** requirements in **NGET's** view permit. The probability that the fault clearance times stated in accordance with the **Bilateral Agreement** will be exceeded by any given fault must be less than 2%.



- (b) (i) For the event of failure of the **Protection** systems provided to meet the above fault clearance time requirements, **Back-Up Protection** shall be provided by the **Network Operator** or **Non-Embedded Customer** as the case may be.
  - (ii) **NGET** will also provide **Back-Up Protection**, which will result in a fault clearance time slower than that specified for the **Network Operator** or **Non-Embedded Customer Back-Up Protection** so as to provide **Discrimination**.
  - (iii) For connections with the **National Electricity Transmission System** at 132kV and below, it is normally required that the **Back-Up Protection** on the **National Electricity Transmission System** shall discriminate with the **Network Operator** or **Non-Embedded Customer's Back-Up Protection**.
  - (iv) For connections with the **National Electricity Transmission System** at 400kV or 275kV, the **Back-Up Protection** will be provided by the **Network Operator** or **Non-Embedded Customer**, as the case may be, with a fault clearance time not slower than 300mS for faults on the **Network Operator's** or **Non-Embedded Customer's Apparatus**.
  - (v) Such **Protection** will also be required to withstand, without tripping, the loading incurred during the clearance of a fault on the **National Electricity Transmission System** by breaker fail **Protection** at 400kV or 275kV. This will permit **Discrimination** between **Network Operator** or **Non-Embedded Customer**, as the case may be, **Back-Up Protection** and **Back-Up Protection** provided on the **National Electricity Transmission System** and other **User Systems**. The requirement for and level of **Discrimination** required will be specified in the **Bilateral Agreement**.
- (c) (i) Where the **Network Operator** or **Non-Embedded Customer** is connected to the **National Electricity Transmission System** at 400kV or 275kV, and in Scotland also at 132kV, and a circuit breaker is provided by the **Network Operator** or **Non-Embedded Customer**, or **NGET**, as the case may be, to interrupt the interchange of fault current with the **National Electricity Transmission System** or the **System** of the **Network Operator** or **Non-Embedded Customer**, as the case may be, circuit breaker fail **Protection** will be provided by the **Network Operator** or **Non-Embedded Customer**, or **NGET**, as the case may be, on this circuit breaker.
  - (ii) In the event, following operation of a **Protection** system, of a failure to interrupt fault current by these circuit-breakers within the **Fault Current Interruption Time**, the circuit breaker fail **Protection** is required to initiate tripping of all the necessary electrically adjacent circuit-breakers so as to interrupt the fault current within the next 200 ms.
- (d) The target performance for the **System Fault Dependability Index** shall be not less than 99%. This is a measure of the ability of **Protection** to initiate successful tripping of circuit breakers which are associated with the faulty items of **Apparatus**.

- CC.6.2.3.2 Fault Disconnection Facilities
- (a) Where no **Transmission** circuit breaker is provided at the **User's** connection voltage, the **User** must provide **NGET** with the means of tripping all the **User's** circuit breakers necessary to isolate faults or **System** abnormalities on the **National Electricity Transmission System**. In these circumstances, for faults on the **User's System**, the **User's Protection** should also trip higher voltage **Transmission** circuit breakers. These tripping facilities shall be in accordance with the requirements specified in the **Bilateral Agreement**.
- (b) **NGET** may require the installation of a **System to Generator Operational Intertripping Scheme** in order to enable the timely restoration of circuits following power **System** fault(s). These requirements shall be set out in the relevant **Bilateral Agreement**.
- CC.6.2.3.3 Automatic Switching Equipment
- Where automatic reclosure of **Transmission** circuit breakers is required following faults on the **User's System**, automatic switching equipment shall be provided in accordance with the requirements specified in the **Bilateral Agreement**.
- CC.6.2.3.4 Relay Settings
- Protection** and relay settings will be co-ordinated (both on connection and subsequently) across the **Connection Point** in accordance with the **Bilateral Agreement** to ensure effective disconnection of faulty **Apparatus**.
- CC.6.2.3.5 Work on Protection equipment
- Where a **Transmission Licensee** owns the busbar at the **Connection Point**, no busbar **Protection**, mesh corner **Protection** relays, AC or DC wiring (other than power supplies or DC tripping associated with the **Network Operator** or **Non-Embedded Customer's Apparatus** itself) may be worked upon or altered by the **Network Operator** or **Non-Embedded Customer** personnel in the absence of a representative of **NGET** or in Scotland, a representative of **NGET**, or written authority from **NGET** to perform such work or alterations in the absence of a representative of **NGET**.
- CC.6.2.3.6 Equipment to be provided
- CC.6.2.3.6.1 Protection of Interconnecting Connections
- The requirements for the provision of **Protection** equipment for interconnecting connections will be specified in the **Bilateral Agreement**.
- CC.6.3 GENERAL GENERATING UNIT (AND OTSDUW) REQUIREMENTS
- CC.6.3.1 This section sets out the technical and design criteria and performance requirements for **Generating Units**, **DC Converters** and **Power Park Modules** (whether directly connected to the **National Electricity Transmission System** or **Embedded**) and (where provided in this section) **OTSDUW Plant and Apparatus** which each **Generator** or **DC Converter Station** owner must ensure are complied with in relation to its **Generating Units**, **DC Converters** and **Power Park Modules** and **OTSDUW Plant and Apparatus** but does not apply to **Small Power Stations** or individually to **Power Park Units**. References to **Generating Units**, **DC Converters** and **Power Park Modules** in this CC.6.3 should be read accordingly. The performance requirements that **OTSDUW Plant and Apparatus** must be capable of providing at the **Interface Point** under this section may be provided using a combination of **Generator Plant** and **Apparatus** and/or **OTSDUW Plant and Apparatus**.
- Plant Performance Requirements

- (a) When supplying **Rated MW** all **Onshore Synchronous Generating Units** must be capable of continuous operation at any point between the limits **0.85 Power Factor** lagging and **0.95 Power Factor** leading at the **Onshore Synchronous Generating Unit** terminals. At **Active Power** output levels other than **Rated MW**, all **Onshore Synchronous Generating Units** must be capable of continuous operation at any point between the **Reactive Power** capability limits identified on the **Generator Performance Chart**.

In addition to the above paragraph, where **Onshore Synchronous Generating Unit(s)**:

- (i) have a **Connection Entry Capacity** which has been increased above **Rated MW** (or the **Connection Entry Capacity** of the **CCGT module** has increased above the sum of the **Rated MW** of the **Generating Units** comprising the **CCGT module**), and such increase takes effect after 1<sup>st</sup> May 2009, the minimum lagging **Reactive Power** capability at the terminals of the **Onshore Synchronous Generating Unit(s)** must be **0.9 Power Factor** at all **Active Power** output levels in excess of **Rated MW**. Further, the **User** shall comply with the provisions of and any instructions given pursuant to BC1.8 and the relevant **Bilateral Agreement**; or
- (ii) have a **Connection Entry Capacity** in excess of **Rated MW** (or the **Connection Entry Capacity** of the **CCGT module** exceeds the sum of **Rated MW** of the **Generating Units** comprising the **CCGT module**) and a **Completion Date** before 1<sup>st</sup> May 2009, alternative provisions relating to **Reactive Power** capability may be specified in the **Bilateral Agreement** and where this is the case such provisions must be complied with.

The short circuit ratio of **Onshore Synchronous Generating Units** with an **Apparent Power** rating of less than 1600MVA shall be not less than 0.5. The short circuit ratio of **Onshore Synchronous Generating Units** with a rated **Apparent Power** of 1600MVA or above shall be not less than 0.4.

- (b) Subject to paragraph (c) below, all **Onshore Non-Synchronous Generating Units**, **Onshore DC Converters** and **Onshore Power Park Modules** must be capable of maintaining zero transfer of **Reactive Power** at the **Onshore Grid Entry Point** (or **User System Entry Point** if **Embedded**) at all **Active Power** output levels under steady state voltage conditions. For **Onshore Non-Synchronous Generating Units** and **Onshore Power Park Modules** the steady state tolerance on **Reactive Power** transfer to and from the **National Electricity Transmission System** expressed in MVA shall be no greater than 5% of the **Rated MW**. For **Onshore DC Converters** the steady state tolerance on **Reactive Power** transfer to and from the **National Electricity Transmission System** shall be specified in the **Bilateral Agreement**.

(c) Subject to the provisions of CC.6.3.2(d) below, all **Onshore Non-Synchronous Generating Units, Onshore DC Converters** (excluding current source technology) and **Onshore Power Park Modules** (excluding those connected to the **Total System** by a current source **Onshore DC Converter**) and **OTSDUW Plant and Apparatus** at the **Interface Point** with a **Completion Date** on or after 1 January 2006 must be capable of supplying **Rated MW** output or **Interface Point Capacity** in the case of **OTSDUW Plant and Apparatus** at any point between the limits 0.95 **Power Factor** lagging and 0.95 **Power Factor** leading at the **Onshore Grid Entry Point** in England and Wales or **Interface Point** in the case of **OTSDUW Plant and Apparatus** or at the HV side of the 33/132kV or 33/275kV or 33/400kV transformer for **Generators** directly connected to the **Onshore Transmission System** in Scotland (or **User System Entry Point** if **Embedded**). With all **Plant** in service, the **Reactive Power** limits defined at **Rated MW** or **Interface Point Capacity** in the case of **OTSDUW Plant and Apparatus** at Lagging **Power Factor** will apply at all **Active Power** output levels above 20% of the **Rated MW** or **Interface Point Capacity** in the case of **OTSDUW Plant and Apparatus** output as defined in Figure 1. With all **Plant** in service, the **Reactive Power** limits defined at **Rated MW** at Leading **Power Factor** will apply at all **Active Power** output levels above 50% of the **Rated MW** output or **Interface Point Capacity** in the case of **OTSDUW Plant and Apparatus** as defined in Figure 1. With all **Plant** in service, the **Reactive Power** limits will reduce linearly below 50% **Active Power** output as shown in Figure 1 unless the requirement to maintain the **Reactive Power** limits defined at **Rated MW** or **Interface Point Capacity** in the case of **OTSDUW Plant and Apparatus** at Leading **Power Factor** down to 20% **Active Power** output is specified in the **Bilateral Agreement**. These **Reactive Power** limits will be reduced pro rata to the amount of **Plant** in service.

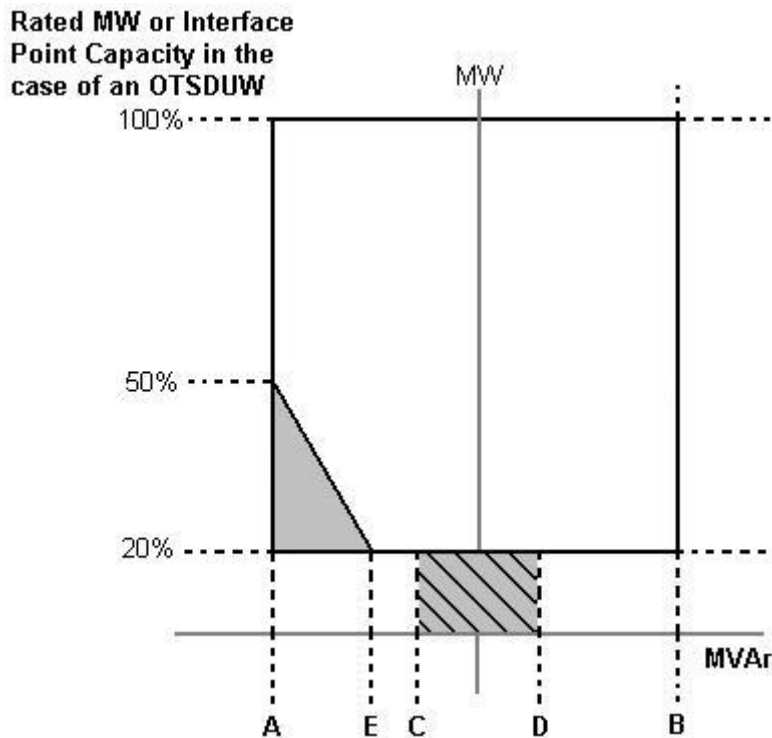

Figure 1

Point A is equivalent (in MVar) to

0.95 leading Power Factor at Rated MW output or **Interface Point Capacity** in the case of **OTSDUW Plant and Apparatus**

|                                     |  |
|-------------------------------------|--|
| Point B is equivalent (in MVar) to: | 0.95 lagging Power Factor at Rated MW output or <b>Interface Point Capacity</b> in the case of <b>OTSDUW Plant and Apparatus</b> |
| Point C is equivalent (in MVar) to: | -5% of Rated MW output or <b>Interface Point Capacity</b> in the case of <b>OTSDUW Plant and Apparatus</b>                       |
| Point D is equivalent (in MVar) to: | +5% of Rated MW output or <b>Interface Point Capacity</b> in the case of <b>OTSDUW Plant and Apparatus</b>                       |
| Point E is equivalent (in MVar) to: | -12% of Rated MW output or <b>Interface Point Capacity</b> in the case of <b>OTSDUW Plant and Apparatus</b>                      |

- (d) All **Onshore Non-Synchronous Generating Units** and **Onshore Power Park Modules** in Scotland with a **Completion Date** after 1 April 2005 and before 1 January 2006 must be capable of supplying **Rated MW** at the range of power factors either:
- (i) from 0.95 lead to 0.95 lag as illustrated in Figure 1 at the **User System Entry Point** for **Embedded Generators** or at the HV side of the 33/132kV or 33/275kV or 33/400kV transformer for **Generators** directly connected to the **Onshore Transmission System**. With all **Plant** in service, the **Reactive Power** limits defined at **Rated MW** will apply at all **Active Power** output levels above 20% of the **Rated MW** output as defined in Figure 1. These **Reactive Power** limits will be reduced pro rata to the amount of **Plant** in service, or
  - (ii) from 0.95 lead to 0.90 lag at the **Onshore Non-Synchronous Generating Unit** (including **Power Park Unit**) terminals. For the avoidance of doubt **Generators** complying with this option (ii) are not required to comply with CC.6.3.2(b).
- (e) The short circuit ratio of Offshore Synchronous Generating Units at a Large Power Station shall be not less than 0.5. At a Large Power Station all Offshore Synchronous Generating Units, Offshore Non-Synchronous Generating Units, Offshore DC Converters and **Offshore Power Park Modules** must be capable of maintaining:
- (i) zero transfer of **Reactive Power** at the **Offshore Grid Entry Point** for all **Generators** with an **Offshore Grid Entry Point** at the **LV Side of the Offshore Platform** at all **Active Power** output levels under steady state voltage conditions. The steady state tolerance on **Reactive Power** transfer to and from an **Offshore Transmission System** expressed in MVar shall be no greater than 5% of the **Rated MW**, or
  - (ii) a transfer of **Reactive Power** at the **Offshore Grid Entry Point** at a value specified in the **Bilateral Agreement** that will be equivalent to zero at the **LV Side of the Offshore Platform**. In addition, the steady state tolerance on **Reactive Power** transfer to and from an **Offshore Transmission System** expressed in MVar at the **LV Side of the Offshore Platform** shall be no greater than 5% of the **Rated MW**, or
  - (iii) the **Reactive Power** capability (within associated steady state tolerance) specified in the **Bilateral Agreement** if any alternative has been agreed with the **Generator**, **Offshore Transmission Licensee** and **NGET**.

CC.6.3.3

Each **Generating Unit, DC Converter** (including an **OTSDUW DC Converter**), **Power Park Module** and/or **CCGT Module** must be capable of:

- (a) continuously maintaining constant **Active Power** output for **System Frequency** changes within the range 50.5 to 49.5 Hz; and

- (b) (subject to the provisions of CC.6.1.3) maintaining its **Active Power** output at a level not lower than the figure determined by the linear relationship shown in Figure 2 for **System Frequency** changes within the range 49.5 to 47 Hz, such that if the **System Frequency** drops to 47 Hz the **Active Power** output does not decrease by more than 5%. In the case of a **CCGT Module**, the above requirement shall be retained down to the **Low Frequency Relay** trip setting of 48.8 Hz, which reflects the first stage of the Automatic Low **Frequency Demand Disconnection** scheme notified to **Network Operators** under OC6.6.2. For **System Frequency** below that setting, the existing requirement shall be retained for a minimum period of 5 minutes while **System Frequency** remains below that setting, and special measure(s) that may be required to meet this requirement shall be kept in service during this period. After that 5 minutes period, if **System Frequency** remains below that setting, the special measure(s) must be discontinued if there is a materially

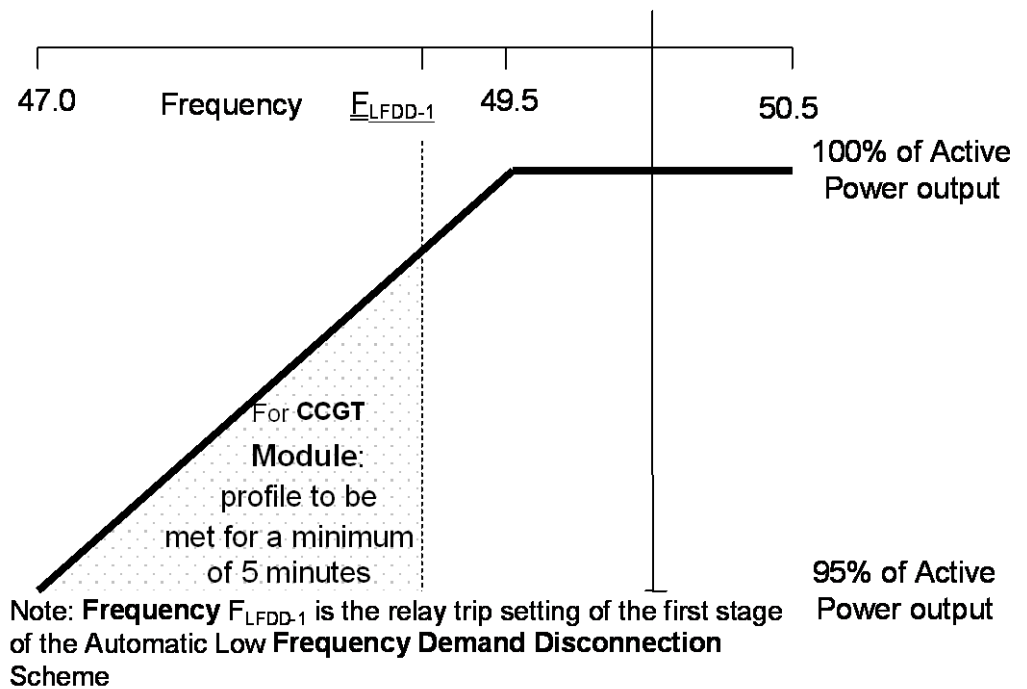

Figure 2

- (c) For the avoidance of doubt in the case of a **Generating Unit** or **Power Park Module** (or **OTSDUW DC Converters** at the **Interface Point**) using an **Intermittent Power Source** where the mechanical power input will not be constant over time, the requirement is that the **Active Power** output shall be independent of **System Frequency** under (a) above and should not drop with **System Frequency** by greater than the amount specified in (b) above.
- (d) A **DC Converter Station** must be capable of maintaining its **Active Power** input (i.e. when operating in a mode analogous to **Demand**) from the **National Electricity Transmission System** (or **User System** in the case of an **Embedded DC Converter Station**) at a level not greater than the figure determined by the linear relationship shown in Figure 3 for **System Frequency** changes within the range 49.5 to 47 Hz, such that if the **System Frequency** drops to 47.8 Hz the **Active Power** input decreases by more than 60%.

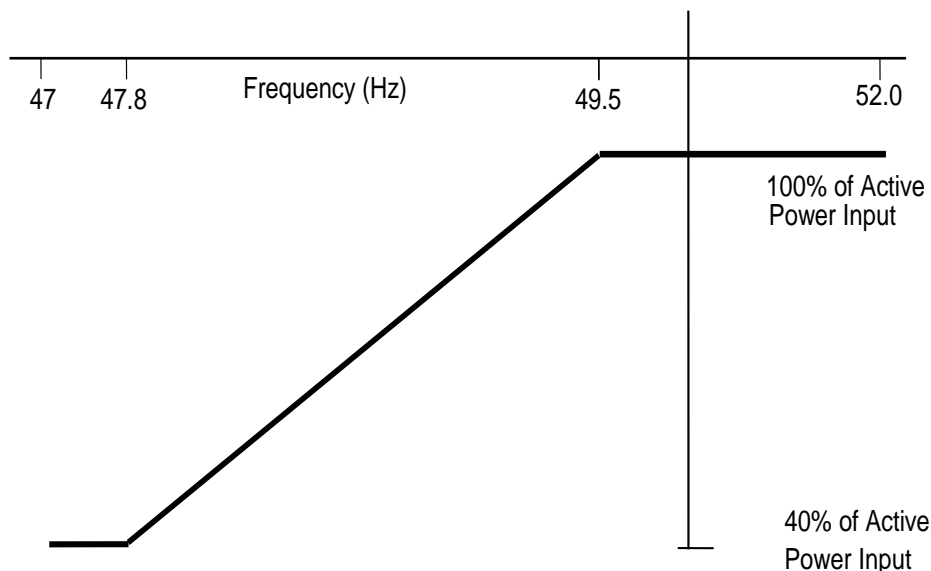

Figure 3

- (e) At a **Large Power Station**, in the case of an **Offshore Generating Unit**, **Offshore Power Park Module**, **Offshore DC Converter** and **OTSDUW DC Converter**, the **Generator** shall comply with the requirements of CC.6.3.3. **Generators** should be aware that Section K of the **STC** places requirements on **Offshore Transmission Licensees** which utilise a **Transmission DC Converter** as part of their **Offshore Transmission System** to make appropriate provisions to enable **Generators** to fulfil their obligations.
- (f) In the case of an **OTSDUW DC Converter** the **OTSDUW Plant and Apparatus** shall provide a continuous signal indicating the real time frequency measured at the **Interface Point** to the **Offshore Grid Entry Point**.

CC.6.3.4

At the **Grid Entry Point**, the **Active Power** output under steady state conditions of any **Generating Unit**, **DC Converter** or **Power Park Module** directly connected to the **National Electricity Transmission System** or in the case of **OTSDUW**, the **Active Power** transfer at the **Interface Point**, under steady state conditions of any **OTSDUW Plant and Apparatus** should not be affected by voltage changes in the normal operating range specified in paragraph CC.6.1.4 by more than the change in **Active Power** losses at reduced or increased voltage. In addition:

- (a) For any **Onshore Generating Unit**, **Onshore DC Converter** and **Onshore Power Park Module** or **OTSDUW** the **Reactive Power** output under steady state conditions should be fully available within the voltage range  $\pm 5\%$  at 400kV, 275kV and 132kV and lower voltages, except for an **Onshore Power Park Module** or **Onshore Non-Synchronous Generating Unit** if **Embedded** at 33kV and below (or directly connected to the **Onshore Transmission System** at 33kV and below) where the requirement shown in Figure 4 applies.
- (b) At a **Large Power Station**, in the case of an **Offshore Generating Unit**, **Offshore DC Converter** and **Offshore Power Park Module** where an alternative reactive capability has been agreed with the **Generator**, as specified in CC.6.3.2(e) (iii), the voltage / **Reactive Power** requirement shall be specified in the **Bilateral Agreement**. The **Reactive Power** output under steady state conditions shall be fully available within the voltage range  $\pm 5\%$  at 400kV, 275kV and 132kV and lower voltages.



Voltage at an **Onshore Grid Entry Point** or **User System Entry Point** if **Embedded** (% of Nominal) at 33 kV and below

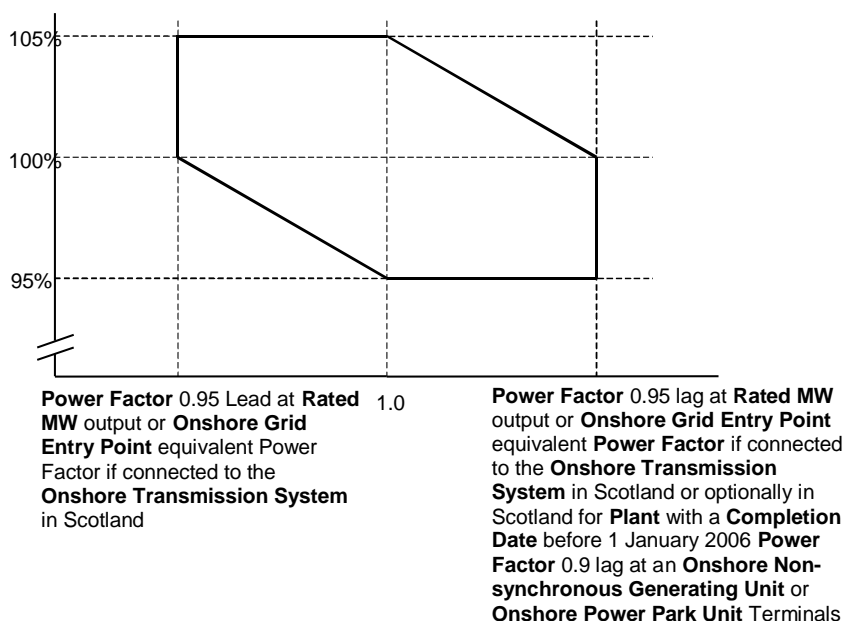

Figure 4

CC.6.3.5 It is an essential requirement that the **National Electricity Transmission System** must incorporate a **Black Start Capability**. This will be achieved by agreeing a **Black Start Capability** at a number of strategically located **Power Stations**. For each **Power Station** NGET will state in the **Bilateral Agreement** whether or not a **Black Start Capability** is required.

Control Arrangements

- CC.6.3.6 (a) Each:
- (i) **Offshore Generating Unit** in a **Large Power Station** or **Onshore Generating Unit**; or,
  - (ii) **Onshore DC Converter** with a **Completion Date** on or after 1 April 2005 or **Offshore DC Converter** at a **Large Power Station**; or,
  - (iii) **Onshore Power Park Module** in England and Wales with a **Completion Date** on or after 1 January 2006; or,
  - (iv) **Onshore Power Park Module** in operation in Scotland on or after 1 January 2006 (with a **Completion Date** after 1 July 2004 and in a **Power Station** with a **Registered Capacity** of 50MW or more); or,
  - (v) **Offshore Power Park Module** in a **Large Power Station** with a **Registered Capacity** of 50MW or more;

must be capable of contributing to **Frequency** control by continuous modulation of **Active Power** supplied to the **National Electricity Transmission System** or the **User System** in which it is **Embedded**. For the avoidance of doubt each **OTSDUW DC Converter** shall provide each **User** in respect of its **Offshore Power Stations** connected to and/or using an **Offshore Transmission System** a continuous signal indicating the real time **Frequency** measured at the **Transmission Interface Point**.

- (b) Each:
- (i) **Onshore Generating Unit**; or,
  - (ii) **Onshore DC Converter** (with a **Completion Date** on or after 1 April 2005 excluding current source technologies); or

- (iii) **Onshore Power Park Module** in England and Wales with a **Completion Date** on or after 1 January 2006; or,
- (iv) **Onshore Power Park Module** in Scotland irrespective of **Completion Date**; or,
- (v) **Offshore Generating Unit** at a **Large Power Station**, **Offshore DC Converter** at a **Large Power Station** or **Offshore Power Park Module** at a **Large Power Station** which provides a reactive range beyond the minimum requirements specified in CC.6.3.2(e) (iii); or,
- (vi) **OTSDUW Plant and Apparatus** at a **Transmission Interface Point**

must be capable of contributing to voltage control by continuous changes to the **Reactive Power** supplied to the **National Electricity Transmission System** or the **User System** in which it is **Embedded**.

CC.6.3.7

- (a) Each **Generating Unit**, **DC Converter** or **Power Park Module** (excluding **Onshore Power Park Modules** in Scotland with a **Completion Date** before 1 July 2004 or **Onshore Power Park Modules** in a **Power Station** in Scotland with a **Registered Capacity** less than 50MW or **Offshore Power Park Modules** in a **Large Power Station** located **Offshore** with a **Registered Capacity** less than 50MW) must be fitted with a fast acting proportional **Frequency** control device (or turbine speed governor) and unit load controller or equivalent control device to provide **Frequency** response under normal operational conditions in accordance with **Balancing Code 3 (BC3)**. In the case of a **Power Park Module** the **Frequency** or speed control device(s) may be on the **Power Park Module** or on each individual **Power Park Unit** or be a combination of both. The **Frequency** control device(s) (or speed governor(s)) must be designed and operated to the appropriate:

- (i) **European Specification**; or
- (ii) in the absence of a relevant **European Specification**, such other standard which is in common use within the European Community (which may include a manufacturer specification);

as at the time when the installation of which it forms part was designed or (in the case of modification or alteration to the **Frequency** control device (or turbine speed governor)) when the modification or alteration was designed.

The **European Specification** or other standard utilised in accordance with sub-paragraph CC.6.3.7 (a) (ii) will be notified to **NGET** by the **Generator** or **DC Converter Station** owner or, in the case of an **Embedded Medium Power Station** not subject to a **Bilateral Agreement** or **Embedded DC Converter Station** not subject to a **Bilateral Agreement**, the relevant **Network Operator**:

- (i) as part of the application for a **Bilateral Agreement**; or
- (ii) as part of the application for a varied **Bilateral Agreement**; or
- (iii) in the case of an **Embedded Development**, within 28 days of entry into the **Embedded Development Agreement** (or such later time as agreed with **NGET**); or
- (iv) as soon as possible prior to any modification or alteration to the **Frequency** control device (or governor); and

- (b) The **Frequency** control device (or speed governor) in co-ordination with other control devices must control the **Generating Unit, DC Converter or Power Park Module Active Power Output** with stability over the entire operating range of the **Generating Unit, DC Converter or Power Park Module**; and
- (c) The **Frequency** control device (or speed governor) must meet the following minimum requirements:
  - (i) Where a **Generating Unit, DC Converter or Power Park Module** becomes isolated from the rest of the **Total System** but is still supplying **Customers**, the **Frequency** control device (or speed governor) must also be able to control **System Frequency** below 52Hz unless this causes the **Generating Unit, DC Converter or Power Park Module** to operate below its **Designed Minimum Operating Level** when it is possible that it may, as detailed in BC 3.7.3, trip after a time. For the avoidance of doubt the **Generating Unit, DC Converter or Power Park Module** is only required to operate within the **System Frequency** range 47 - 52 Hz as defined in CC.6.1.3;
  - (ii) the **Frequency** control device (or speed governor) must be capable of being set so that it operates with an overall speed **Droop** of between 3% and 5%. For the avoidance of doubt, in the case of a **Power Park Module** the speed **Droop** should be equivalent of a fixed setting between 3% and 5% applied to each **Power Park Unit** in service;
  - (iii) in the case of all **Generating Units, DC Converter or Power Park Module** other than the **Steam Unit** within a **CCGT Module** the **Frequency** control device (or speed governor) deadband should be no greater than 0.03Hz (for the avoidance of doubt,  $\pm 0.015\text{Hz}$ ). In the case of the **Steam Unit** within a **CCGT Module**, the speed **Governor Deadband** should be set to an appropriate value consistent with the requirements of CC.6.3.7(c)(i) and the requirements of BC3.7.2 for the provision of **Limited High Frequency Response**;

For the avoidance of doubt, the minimum requirements in (ii) and (iii) for the provision of **System Ancillary Services** do not restrict the negotiation of **Commercial Ancillary Services** between **NGET** and the **User** using other parameters; and

- (d) A facility to modify, so as to fulfil the requirements of the **Balancing Codes**, the **Target Frequency** setting either continuously or in a maximum of 0.05 Hz steps over at least the range  $50 \pm 0.1$  Hz should be provided in the unit load controller or equivalent device.
- (e)
  - (i) Each **Onshore Generating Unit** and/or **CCGT Module** which has a **Completion Date** after 1 January 2001 in England and Wales, and after 1 April 2005 in Scotland, must be capable of meeting the minimum **Frequency** response requirement profile subject to and in accordance with the provisions of Appendix 3.
  - (ii) Each **DC Converter** at a **DC Converter Station** which has a **Completion Date** on or after 1 April 2005 and each **Offshore DC Converter** at a **Large Power Station** must be capable of meeting the minimum **Frequency** response requirement profile subject to and in accordance with the provisions of Appendix 3.
  - (iii) Each **Onshore Power Park Module** in operation in England and Wales with a **Completion Date** on or after 1 January 2006 must be capable of meeting the minimum **Frequency** response requirement

profile subject to and in accordance with the provisions of Appendix 3.

- (iv) Each **Onshore Power Park Module** in operation on or after 1 January 2006 in Scotland (with a **Completion Date** on or after 1 April 2005 and a **Registered Capacity** of 50MW or more) must be capable of meeting the minimum **Frequency** response requirement profile subject to and in accordance with the provisions of Appendix 3.
  - (v) Each **Offshore Generating Unit** in a **Large Power Station** must be capable of meeting the minimum **Frequency** response requirement profile subject to and in accordance with the provisions of Appendix 3.
  - (vi) Each **Offshore Power Park Module** in a **Large Power Station** with a **Registered Capacity** of 50 MW or greater, must be capable of meeting the minimum **Frequency** response requirement profile subject to and in accordance with the provisions of Appendix 3.
  - (vii) Subject to the requirements of CC.6.3.7(e), **Offshore Generating Units** at a **Large Power Station**, **Offshore Power Park Modules** at a **Large Power Station** and **Offshore DC Converters** in a **Large Power Station** shall comply with the requirements of CC.6.3.7. **Generators** should be aware that Section K of the **STC** places requirements on **Offshore Transmission Licensees** which utilise a **Transmission DC Converter** as part of their **Offshore Transmission System** to make appropriate provisions to enable **Generators** to fulfil their obligations.
  - (viii) Each **OTSDUW DC Converter** must be capable of providing a continuous signal indicating the real time frequency measured at the **Interface Point** to the **Offshore Grid Entry Point**.
- (f) For the avoidance of doubt, the requirements of Appendix 3 do not apply to:
- (i) **Generating Units** and/or **CCGT Modules** which have a **Completion Date** before 1 January 2001 in England and Wales, and before 1 April 2005 in Scotland, for whom the remaining requirements of this clause CC.6.3.7 shall continue to apply unchanged; or
  - (ii) **DC Converters** at a **DC Converter Station** which have a **Completion Date** before 1 April 2005; or
  - (iii) **Onshore Power Park Modules** in England and Wales with a **Completion Date** before 1 January 2006 for whom only the requirements of **Limited Frequency Sensitive Mode** (BC3.5.2) operation shall apply; or
  - (iv) **Onshore Power Park Modules** in operation in Scotland before 1 January 2006 for whom only the requirements of **Limited Frequency Sensitive Mode** (BC3.5.2) operation shall apply; or
  - (v) **Onshore Power Park Modules** in operation after 1 January 2006 in Scotland which have a **Completion Date** before 1 April 2005 for whom the remaining requirements of this clause CC.6.3.7 shall continue to apply unchanged; or
  - (vi) **Offshore Power Park Modules** which are in a **Large Power Station** with a **Registered Capacity** less than 50MW for whom only the requirements of **Limited Frequency Sensitive Mode** (BC3.5.2) operation shall apply; or

- (a) Excitation and voltage control performance requirements applicable to **Onshore Generating Units, Onshore Power Park Modules, Onshore DC Converters and OTSDUW Plant and Apparatus.**
- (i) A continuously-acting automatic excitation control system is required to provide constant terminal voltage control of the **Onshore Synchronous Generating Unit** without instability over the entire operating range of the **Onshore Generating Unit.**
- (ii) In respect of **Onshore Synchronous Generating Units** with a **Completion Date** before 1 January 2009, the requirements for excitation control facilities, including **Power System Stabilisers**, where in **NGET's** view these are necessary for system reasons, will be specified in the **Bilateral Agreement.** If any **Modification** to the excitation control facilities of such **Onshore Synchronous Generating Units** is made on or after 1 January 2009 the requirements that shall apply may be specified in the **Bilateral Agreement** as varied. To the extent that the **Bilateral Agreement** does not specify, the requirements given or referred to in CC.A.6 shall apply. The performance requirements for a continuously acting automatic excitation control system that shall be complied with by the **User** in respect of such **Onshore Synchronous Generating Units** with a **Completion Date** on or after 1 January 2009 are given or referred to in CC.A.6. Reference is made to on-load commissioning witnessed by **NGET** in BC2.11.2.
- (iii) In the case of an **Onshore Non-Synchronous Generating Unit, Onshore DC Converter, Onshore Power Park Module or OTSDUW Plant and Apparatus** at the **Interface Point** a continuously-acting automatic control system is required to provide control of the voltage (or zero transfer of **Reactive Power** as applicable to CC.6.3.2) at the **Onshore Grid Entry Point** or **User System Entry Point** or in the case of **OTSDUW Plant and Apparatus at the Interface Point** without instability over the entire operating range of the **Onshore Non-Synchronous Generating Unit, Onshore DC Converter, Onshore Power Park Module or OTSDUW Plant and Apparatus.** Any **Plant** or **Apparatus** used in the provisions of such voltage control within an **Onshore Power Park Module** may be located at the **Power Park Unit** terminals, an appropriate intermediate busbar or the **Connection Point.** **OTSDUW Plant and Apparatus** used in the provision of such voltage control may be located at the **Offshore Grid Entry Point,** an appropriate intermediate busbar or at the **Interface Point.** In the case of an **Onshore Power Park Module** in Scotland with a **Completion Date** before 1 January 2009, voltage control may be at the **Power Park Unit** terminals, an appropriate intermediate busbar or the **Connection Point** as specified in the **Bilateral Agreement.** When operating below **20% Rated MW** the automatic control system may continue to provide voltage control utilising any available reactive capability. If voltage control is not being provided the automatic control system shall be designed to ensure a smooth transition between the shaded area bound by CD and the non shaded area bound by AB in Figure 1 of CC.6.3.2 (c).
- (iv) The performance requirements for a continuously acting automatic voltage control system in respect of **Onshore Power Park Modules, Onshore Non-Synchronous Generating Units and Onshore DC Converters** with a **Completion Date** before 1 January 2009 will be specified in the **Bilateral Agreement.** If any **Modification** to the continuously acting automatic voltage control system of such **Onshore Power Park Modules, Onshore Non-**

**Synchronous Generating Units** and **Onshore DC Converters** is made on or after 1 January 2009 the requirements that shall apply may be specified in the **Bilateral Agreement** as varied. To the extent that the **Bilateral Agreement** does not specify, the requirements given or referred to in CC.A.7 shall apply. The performance requirements for a continuously acting automatic voltage control system that shall be complied with by the **User** in respect of **Onshore Power Park Modules**, **Onshore Non-Synchronous Generating Units** and **Onshore DC Converters** or **OTSDUW Plant and Apparatus** at the **Interface Point** with a **Completion Date** on or after 1 January 2009 are given or referred to in CC.A.7.

- (v) In particular, other control facilities, including constant **Reactive Power** output control modes and constant **Power Factor** control modes (but excluding VAR limiters) are not required. However, if present in the excitation or voltage control system they will be disabled unless the **Bilateral Agreement** records otherwise. Operation of such control facilities will be in accordance with the provisions contained in **BC2**.
- (b) Excitation and voltage control performance requirements applicable to **Offshore Generating Units** at a **Large Power Station**, **Offshore Power Park Modules** at a **Large Power Station** and **Offshore DC Converters** at a **Large Power Station**.

A continuously acting automatic control system is required to provide either:

- (i) control of **Reactive Power** (as specified in CC.6.3.2(e) (i) (ii)) at the **Offshore Grid Entry Point** without instability over the entire operating range of the **Offshore Generating Unit**, **Offshore DC Converter** or **Offshore Power Park Module**. The performance requirements for this automatic control system will be specified in the **Bilateral Agreement** or;
- (ii) where an alternative reactive capability has been specified in the **Bilateral Agreement**, in accordance with CC.6.3.2 (e) (iii), the **Offshore Generating Unit**, **Offshore Power Park Module** or **Offshore DC Converter** will be required to control voltage and / or **Reactive Power** without instability over the entire operating range of the **Offshore Generating Unit**, **Offshore Power Park Module** or **Offshore DC Converter**. The performance requirements of the control system will be specified in the **Bilateral Agreement**.

In addition to CC.6.3.8(b) (i) and (ii) the requirements for excitation control facilities, including **Power System Stabilisers**, where in **NGET's** view these are necessary for system reasons, will be specified in the **Bilateral Agreement**. Reference is made to on-load commissioning witnessed by **NGET** in BC2.11.2.

#### Steady state Load Inaccuracies

CC.6.3.9

The standard deviation of **Load** error at steady state **Load** over a 30 minute period must not exceed 2.5 per cent of a **Genset's Registered Capacity**. Where a **Genset** is instructed to **Frequency** sensitive operation, allowance will be made in determining whether there has been an error according to the governor droop characteristic registered under the **PC**.

For the avoidance of doubt in the case of a **Power Park Module** allowance will be made for the full variation of mechanical power output.

#### Negative Phase Sequence Loadings

CC.6.3.10 In addition to meeting the conditions specified in CC.6.1.5(b), each **Synchronous Generating Unit** will be required to withstand, without tripping, the negative phase sequence loading incurred by clearance of a close-up phase-to-phase fault, by **System Back-Up Protection** on the **National Electricity Transmission System** or **User System** located **Onshore** in which it is **Embedded**.

Neutral Earthing

CC.6.3.11 At nominal **System** voltages of 132kV and above the higher voltage windings of a transformer of a **Generating Unit, DC Converter, Power Park Module** or transformer resulting from **OTSDUW** must be star connected with the star point suitable for connection to earth. The earthing and lower voltage winding arrangement shall be such as to ensure that the **Earth Fault Factor** requirement of paragraph CC.6.2.1.1 (b) will be met on the **National Electricity Transmission System** at nominal **System** voltages of 132kV and above.

Frequency Sensitive Relays

CC.6.3.12 As stated in CC.6.1.3, the **System Frequency** could rise to 52Hz or fall to 47Hz. Each **Generating Unit, DC Converter, OTSDUW Plant and Apparatus, Power Park Module** or any constituent element must continue to operate within this **Frequency** range for at least the periods of time given in CC.6.1.3 unless **NET** has agreed to any **Frequency**-level relays and/or rate-of-change-of-**Frequency** relays which will trip such **Generating Unit, DC Converter, OTSDUW Plant and Apparatus, Power Park Module** and any constituent element within this **Frequency** range, under the **Bilateral Agreement**.

CC.6.3.13 **Generators** (including in respect of **OTSDUW Plant and Apparatus**) and **DC Converter Station** owners will be responsible for protecting all their **Generating Units** (and **OTSDUW Plant and Apparatus**), **DC Converters** or **Power Park Modules** against damage should **Frequency** excursions outside the range 52Hz to 47Hz ever occur. Should such excursions occur, it is up to the **Generator** or **DC Converter Station** owner to decide whether to disconnect his **Apparatus** for reasons of safety of **Apparatus, Plant** and/or personnel.

CC.6.3.14 It may be agreed in the **Bilateral Agreement** that a **Genset** shall have a **Fast-Start Capability**. Such **Gensets** may be used for **Operating Reserve** and their **Start-Up** may be initiated by **Frequency**-level relays with settings in the range 49Hz to 50Hz as specified pursuant to **OC2**.

CC.6.3.15 Fault Ride Through

This section sets out the fault ride through requirements on **Generating Units, Power Park Modules, DC Converters and OTSDUW Plant and Apparatus. Onshore Generating Units, Onshore Power Park Modules, Onshore DC Converters** (including **Embedded Medium Power Stations** and **Embedded DC Converter Stations** not subject to a **Bilateral Agreement** and with an **Onshore User System Entry Point** (irrespective of whether they are located **Onshore** or **Offshore**)) and **OTSDUW Plant and Apparatus** are required to operate through **System** faults and disturbances as defined in CC.6.3.15.1 (a), CC.6.3.15.1 (b) and CC.6.3.15.3. **Offshore Generating Units** at a **Large Power Station, Offshore Power Park Modules** at a **Large Power Station** and **Offshore DC Converters** at a **Large Power Station** shall have the option of meeting either:

- (i) CC.6.3.15.1 (a), CC.6.3.15.1 (b) and CC.6.3.15.3, or:
- (ii) CC.6.3.15.2 (a), CC.6.3.15.2 (b) and CC.6.3.15.3

**Offshore Generators** and **Offshore DC Converter** owners, should notify **NGET** which option they wish to select within 28 days (or such longer period as **NGET** may agree, in any event this being no later than 3 months before the **Completion Date** of the offer for a final **CUSC Contract** which would be made following the appointment of the **Offshore Transmission Licensee**).

CC.6.3.15.1 Fault Ride through applicable to Generating Units, Power Park Modules and DC Converters and **OTSDUW Plant and Apparatus**

- (a) Short circuit faults on the **Onshore Transmission System** (which may include an **Interface Point**) at **Supergrid Voltage** up to 140ms in duration.
  - (i) Each **Generating Unit, DC Converter, or Power Park Module** and any constituent **Power Park Unit** thereof and **OTSDUW Plant and Apparatus** shall remain transiently stable and connected to the **System** without tripping of any **Generating Unit, DC Converter or Power Park Module** and / or any constituent **Power Park Unit** and **OTSDUW Plant and Apparatus**, for a close-up solid three-phase short circuit fault or any unbalanced short circuit fault on the **Onshore Transmission System** (including in respect of **OTSDUW Plant and Apparatus, the Interface Point**) operating at **Supergrid Voltages** for a total fault clearance time of up to 140 ms. A solid three-phase or unbalanced earthed fault results in zero voltage on the faulted phase(s) at the point of fault. The duration of zero voltage is dependent on local **Protection** and circuit breaker operating times. This duration and the fault clearance times will be specified in the **Bilateral Agreement**. Following fault clearance, recovery of the **Supergrid Voltage** on the **Onshore Transmission System** to 90% may take longer than 140ms as illustrated in Appendix 4A Figures CC.A.4A.1 (a) and (b). It should be noted that in the case of an **Offshore Generating Unit, Offshore DC Converter or Offshore Power Park Module** (including any **Offshore Power Park Unit** thereof) which is connected to an **Offshore Transmission System** which includes a **Transmission DC Converter** as part of that **Offshore Transmission System**, the **Offshore Grid Entry Point** voltage may not indicate the presence of a fault on the **Onshore Transmission System**. The fault will affect the level of **Active Power** that can be transferred to the **Onshore Transmission System** and therefore subject the **Offshore Generating Unit, Offshore DC Converter or Offshore Power Park Module** (including any **Offshore Power Park Unit** thereof) to a load rejection.



(ii) Each **Generating Unit, Power Park Module and OTSDUW Plant and Apparatus**, shall be designed such that upon both clearance of the fault on the **Onshore Transmission System** as detailed in CC.6.3.15.1 (a) (i) and within 0.5 seconds of the restoration of the voltage at the **Onshore Grid Entry Point** (for **Onshore Generating Units or Onshore Power Park Modules**) or **Interface Point** (for **Offshore Generating Units, Offshore Power Park Modules or OTSDUW Plant and Apparatus**) to the minimum levels specified in CC.6.1.4 (or within 0.5 seconds of restoration of the voltage at the **User System Entry Point** to 90% of nominal or greater if **Embedded**), **Active Power** output or in the case of **OTSDUW Plant and Apparatus, Active Power** transfer capability, shall be restored to at least 90% of the level available immediately before the fault. Once the **Active Power** output, or in the case of **OTSDUW Plant and Apparatus, Active Power** transfer capability, has been restored to the required level, **Active Power** oscillations shall be acceptable provided that:

- the total **Active Energy** delivered during the period of the oscillations is at least that which would have been delivered if the **Active Power** was constant
- the oscillations are adequately damped

During the period of the fault as detailed in CC.6.3.15.1 (a) (i) for which the voltage at the **Grid Entry Point** (or **Interface Point** in the case of **OTSDUW Plant and Apparatus**) is outside the limits specified in CC.6.1.4, each **Generating Unit or Power Park Module or OTSDUW Plant and Apparatus** shall generate maximum reactive current without exceeding the transient rating limit of the **Generating Unit, OTSDUW Plant and Apparatus or Power Park Module** and / or any constituent **Power Park Unit**.

(iii) Each **DC Converter** shall be designed to meet the **Active Power** recovery characteristics (and **OTSDUW DC Converter** shall be designed to meet the **Active Power** transfer capability at the **Interface Point**) as specified in the **Bilateral Agreement** upon clearance of the fault on the **Onshore Transmission System** as detailed in CC.6.3.15.1 (a) (i).

(b) **Supergrid Voltage** dips on the **Onshore Transmission System** greater than 140ms in duration

In addition to the requirements of CC.6.3.15.1 (a) each **Generating Unit, OTSDUW Plant and Apparatus**, or each **Power Park Module** and / or any constituent **Power Park Unit**, each with a **Completion Date** on or after the 1 April 2005 shall:

(i) remain transiently stable and connected to the **System** without tripping of any **Generating Unit, OTSDUW Plant and Apparatus, or Power Park Module** and / or any constituent **Power Park Unit**, for balanced **Supergrid Voltage** dips and associated durations on the **Onshore Transmission System** (which could be at the **Interface Point**) anywhere on or above the heavy black line shown in Figure 5. Appendix 4A and Figures CC.A.4A.3 (a), (b) and (c) provide an explanation and illustrations of Figure 5; and,

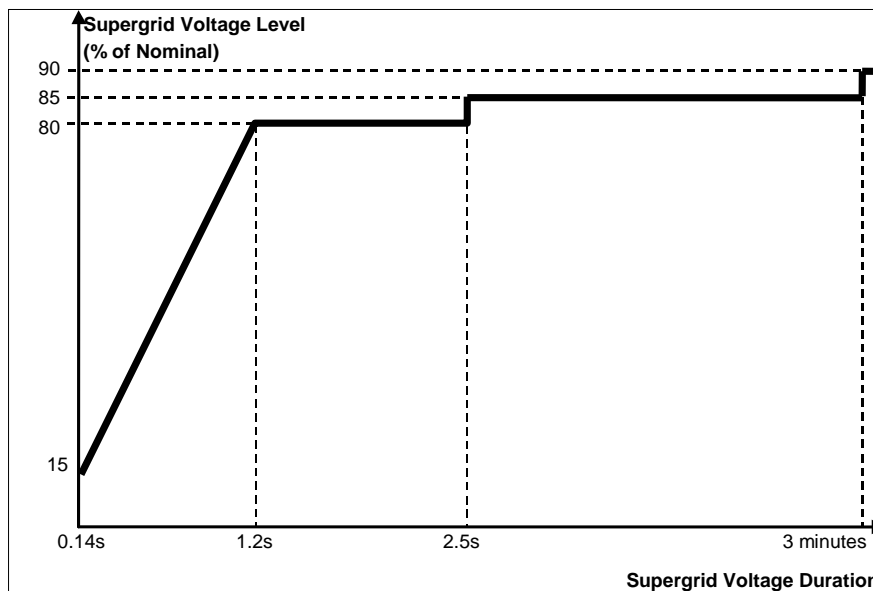

Figure 5

- (ii) provide **Active Power** output at the **Grid Entry Point** or in the case of an **OTSDUW**, **Active Power** transfer capability at the **Transmission Interface Point**, during **Supergrid Voltage** dips on the **Onshore Transmission System** as described in Figure 5, at least in proportion to the retained balanced voltage at the **Onshore Grid Entry Point** (for **Onshore Generating Units** and **Onshore Power Park Modules**) or **Interface Point** (for **Offshore Generating Units**, **OTSDUW Plant and Apparatus** and **Offshore Power Park Modules**) (or the retained balanced voltage at the **User System Entry Point** if **Embedded**) except in the case of a **Non-Synchronous Generating Unit** or **OTSDUW Plant and Apparatus** or **Power Park Module** where there has been a reduction in the **Intermittent Power Source** or in the case of **OTSDUW Active Power** transfer capability in the time range in Figure 5 that restricts the **Active Power** output or in the case of an **OTSDUW Active Power** transfer capability below this level and shall generate maximum reactive current (where the voltage at the **Grid Entry Point**, or in the case of an **OTSDUW Plant and Apparatus**, the **Interface Point** voltage, is outside the limits specified in CC.6.1.4) without exceeding the transient rating limits of the **Generating Unit**, **OTSDUW Plant and Apparatus** or **Power Park Module** and any constituent **Power Park Unit**; and,
- (iii) restore **Active Power** output (or, in the case of **OTSDUW**, **Active Power** transfer capability), following **Supergrid Voltage** dips on the **Onshore Transmission System** as described in Figure 5, within 1 second of restoration of the voltage at the:
- Onshore Grid Entry Point** for directly connected **Onshore Generating Units** and **Onshore Power Park Modules** or,
  - Interface Point** for **Offshore Generating Units**, **OTSDUW Plant and Apparatus** and **Offshore Power Park Modules** or,
  - User System Entry Point** for **Embedded Onshore Generating Units** and **Embedded Onshore Power Park Modules** or,
  - User System Entry Point** for **Embedded Medium Power Stations** and **Embedded DC Converter Stations** not subject to a **Bilateral Agreement** and with an **Onshore User System**

**Entry Point** (irrespective of whether they are located **Onshore** or **Offshore**)

to the minimum levels specified in CC.6.1.4 to at least 90% of the level available immediately before the occurrence of the dip except in the case of a **Non-Synchronous Generating Unit, OTSDUW Plant and Apparatus** or **Power Park Module** where there has been a reduction in the **Intermittent Power Source** in the time range in Figure 5 that restricts the **Active Power** output or, in the case of **OTSDUW**, **Active Power** transfer capability below this level. Once the **Active Power** output or, in the case of **OTSDUW**, **Active Power** transfer capability has been restored to the required level, **Active Power** oscillations shall be acceptable provided that:

- the total **Active Energy** delivered during the period of the oscillations is at least that which would have been delivered if the **Active Power** was constant
- the oscillations are adequately damped.

For the avoidance of doubt a balanced **Onshore Transmission System Supergrid Voltage** meets the requirements of CC.6.1.5 (b) and CC.6.1.6.

CC.6.3.15.2 Fault Ride Through applicable to **Offshore Generating Units** at a **Large Power Station**, **Offshore Power Park Modules** at a **Large Power Station** and **Offshore DC Converters** at a **Large Power Station** who choose to meet the fault ride through requirements at the **LV side of the Offshore Platform**

- (a) Requirements on **Offshore Generating Units, Offshore Power Park Modules** and **Offshore DC Converters** to withstand voltage dips on the **LV Side of the Offshore Platform** for up to 140ms in duration as a result of faults and / or voltage dips on the **Onshore Transmission System** operating at **Supergrid Voltage**
  - (i) Each **Offshore Generating Unit, Offshore DC Converter**, or **Offshore Power Park Module** and any constituent **Power Park Unit** thereof shall remain transiently stable and connected to the **System** without tripping of any **Offshore Generating Unit**, or **Offshore DC Converter** or **Offshore Power Park Module** and / or any constituent **Power Park Unit**, for any balanced or unbalanced voltage dips on the **LV Side of the Offshore Platform** whose profile is anywhere on or above the heavy black line shown in Figure 6. For the avoidance of doubt, the profile beyond 140ms in Figure 6 shows the minimum recovery in voltage that will be seen by the generator following clearance of the fault at 140ms. Appendix 4B and Figures CC.A.4B.2 (a) and (b) provide further illustration of the voltage recovery profile that may be seen. It should be noted that in the case of an **Offshore Generating Unit, Offshore DC Converter** or **Offshore Power Park Module** (including any **Offshore Power Park Unit** thereof) which is connected to an **Offshore Transmission System** which includes a **Transmission DC Converter** as part of that **Offshore Transmission System**, the **Offshore Grid Entry Point** voltage may not indicate the presence of a fault on the **Onshore Transmission System**. The voltage dip will affect the level of **Active Power** that can be transferred to the **Onshore Transmission System** and therefore subject the **Offshore Generating Unit, Offshore DC Converter** or **Offshore Power Park Module** (including any **Offshore Power Park Unit** thereof) to a load rejection.

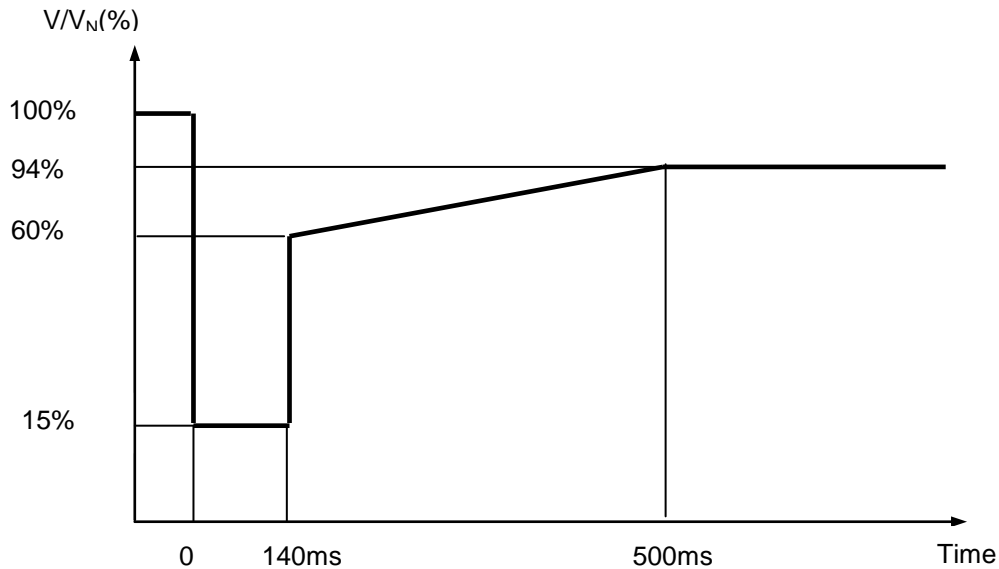

Figure 6

$V/V_N$  is the ratio of the actual voltage on one or more phases at the **LV Side of the Offshore Platform** to the nominal voltage of the **LV Side of the Offshore Platform**.

- (ii) Each **Offshore Generating Unit**, or **Offshore Power Park Module** and any constituent **Power Park Unit** thereof shall provide **Active Power** output, during voltage dips on the **LV Side of the Offshore Platform** as described in Figure 6, at least in proportion to the retained voltage at the **LV Side of the Offshore Platform** except in the case of an **Offshore Non-Synchronous Generating Unit** or **Offshore Power Park Module** where there has been a reduction in the **Intermittent Power Source** in the time range in Figure 6 that restricts the **Active Power** output below this level and shall generate maximum reactive current without exceeding the transient rating limits of the **Offshore Generating Unit** or **Offshore Power Park Module** and any constituent **Power Park Unit**. Once the **Active Power** output has been restored to the required level, **Active Power** oscillations shall be acceptable provided that:
    - the total **Active Energy** delivered during the period of the oscillations is at least that which would have been delivered if the **Active Power** was constant
    - the oscillations are adequately damped
 and;
  - (iii) Each **Offshore DC Converter** shall be designed to meet the **Active Power** recovery characteristics as specified in the **Bilateral Agreement** upon restoration of the voltage at the **LV Side of the Offshore Platform**.
- (b) Requirements of **Offshore Generating Units**, **Offshore Power Park Modules** to withstand voltage dips on the **LV Side of the Offshore Platform** greater than 140ms in duration.

In addition to the requirements of CC.6.3.15.2. (a) each **Offshore Generating Unit** or **Offshore Power Park Module** and / or any constituent **Power Park Unit**, shall:

- (i) remain transiently stable and connected to the **System** without tripping of any **Offshore Generating Unit** or **Offshore Power Park Module** and / or any constituent **Power Park Unit**, for any balanced

voltage dips on the **LV side of the Offshore Platform** and associated durations anywhere on or above the heavy black line shown in Figure 7. Appendix 4B and Figures CC.A.4B.3. (a), (b) and (c) provide an explanation and illustrations of Figure 7. It should be noted that in the case of an **Offshore Generating Unit**, or **Offshore Power Park Module** (including any **Offshore Power Park Unit** thereof) which is connected to an **Offshore Transmission System** which includes a **Transmission DC Converter** as part of that **Offshore Transmission System**, the **Offshore Grid Entry Point** voltage may not indicate the presence of a voltage dip on the **Onshore Transmission System**. The voltage dip will affect the level of **Active Power** that can be transferred to the **Onshore Transmission System** and therefore subject the **Offshore Generating Unit**, or **Offshore Power Park Module** (including any **Offshore Power Park Unit** thereof) to a load rejection.

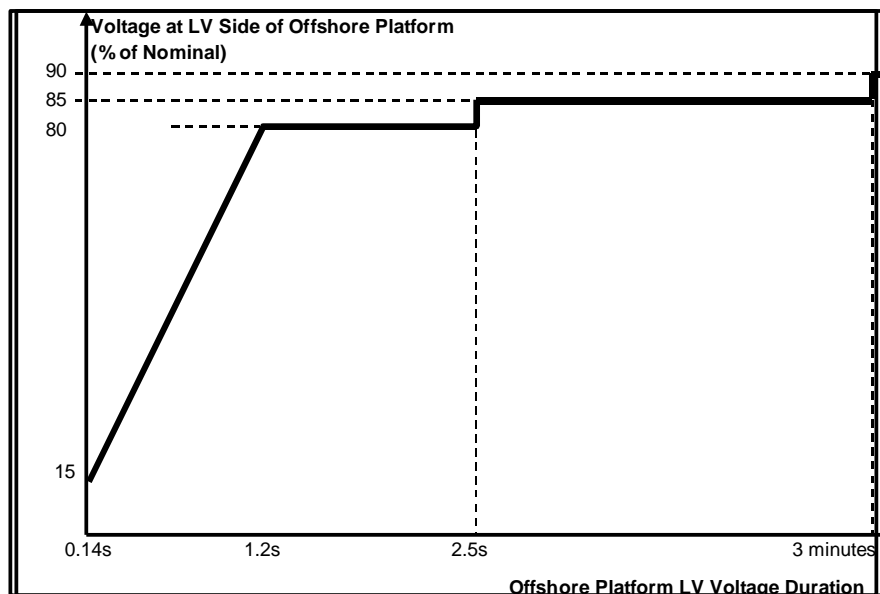

Figure 7

- (ii) provide **Active Power** output, during voltage dips on the **LV Side of the Offshore Platform** as described in Figure 7, at least in proportion to the retained balanced or unbalanced voltage at the **LV Side of the Offshore Platform** except in the case of an **Offshore Non-Synchronous Generating Unit** or **Offshore Power Park Module** where there has been a reduction in the **Intermittent Power Source** in the time range in Figure 7 that restricts the **Active Power** output below this level and shall generate maximum reactive current (where the voltage at the **Offshore Grid Entry Point** is outside the limits specified in CC.6.1.4) without exceeding the transient rating limits of the **Offshore Generating Unit** or **Offshore Power Park Module** and any constituent **Power Park Unit**; and,
- (iii) within 1 second of the restoration of the voltage at the **LV Side of the Offshore Platform** (to the minimum levels specified in CC.6.1.4) restore **Active Power** to at least 90% of the **Offshore Generating Unit's** or **Offshore Power Park Module's** immediate pre-disturbed value, unless there has been a reduction in the **Intermittent Power Source** in the time range in Figure 7 that restricts the **Active Power** output below this level. Once the **Active Power** output has been restored to the required level, **Active Power** oscillations shall be acceptable provided that:

- the total **Active Energy** delivered during the period of the oscillations is at least that which would have been delivered if the **Active Power** was constant
- the oscillations are adequately damped

CC.6.3.15.3 Other Requirements

- (i) In the case of a **Power Park Module** (comprising of wind-turbine generator units), the requirements in CC.6.3.15.1 and CC.6.3.15.2 do not apply when the **Power Park Module** is operating at less than 5% of its **Rated MW** or during very high wind speed conditions when more than 50% of the wind turbine generator units in a **Power Park Module** have been shut down or disconnected under an emergency shutdown sequence to protect **User's Plant** and **Apparatus**.
- (ii) In addition to meeting the conditions specified in CC.6.1.5(b) and CC.6.1.6, each **Non-Synchronous Generating Unit, OTSDUW Plant and Apparatus** or **Power Park Module** with a **Completion Date** after 1 April 2005 and any constituent **Power Park Unit** thereof will be required to withstand, without tripping, the negative phase sequence loading incurred by clearance of a close-up phase-to-phase fault, by **System Back-Up Protection** on the **Onshore Transmission System** operating at **Supergrid Voltage**.
- (iii) In the case of an **Onshore Power Park Module** in Scotland with a **Completion Date** before 1 January 2004 and a **Registered Capacity** less than 30MW the requirements in CC.6.3.15.1 (a) do not apply. In the case of an **Onshore Power Park Module** in Scotland with a **Completion Date** on or after 1 January 2004 and before 1 July 2005 and a **Registered Capacity** less than 30MW the requirements in CC.6.3.15.1 (a) are relaxed from the minimum **Onshore Transmission System Supergrid Voltage** of zero to a minimum **Onshore Transmission System Supergrid Voltage** of 15% of nominal. In the case of an **Onshore Power Park Module** in Scotland with a **Completion Date** before 1 January 2004 and a **Registered Capacity** of 30MW and above the requirements in CC.6.3.15.1 (a) are relaxed from the minimum **Onshore Transmission System Supergrid Voltage** of zero to a minimum **Onshore Transmission System Supergrid Voltage** of 15% of nominal.
- (iv) To avoid unwanted island operation, **Non-Synchronous Generating Units** in Scotland (and those directly connected to a **Scottish Offshore Transmission System**), **Power Park Modules** in Scotland (and those directly connected to a **Scottish Offshore Transmission System**), or **OTSDUW Plant and Apparatus** with an **Interface Point** in Scotland shall be tripped for the following conditions:
  - (1) **Frequency** above 52Hz for more than 2 seconds
  - (2) **Frequency** below 47Hz for more than 2 seconds
  - (3) Voltage as measured at the **Onshore Connection Point** or **Onshore User System Entry Point** or **Offshore Grid Entry Point** or **Interface Point** in the case of **OTSDUW Plant and Apparatus** is below 80% for more than 2.5 seconds
  - (4) Voltage as measured at the **Onshore Connection Point** or **Onshore User System Entry Point** or **Offshore Grid Entry Point** or **Interface Point** in the case of **OTSDUW Plant and Apparatus** is above 120% (115% for 275kV) for more than 1 second.

The times in sections (1) and (2) are maximum trip times. Shorter times may be used to protect the **Non-Synchronous Generating Units**, or **OTSDUW Plant and Apparatus** or **Power Park Modules**.

#### Additional Damping Control Facilities for DC Converters

- CC.6.3.16 (a) **DC Converter** owners, or **Generators** in respect of **OTSDUW DC Converters** or **Network Operators** in the case of an **Embedded DC Converter Station** not subject to a **Bilateral Agreement** must ensure that any of their **Onshore DC Converters** or **OTSDUW DC Converters** will not cause a sub-synchronous resonance problem on the **Total System**. Each **DC Converter** or **OTSDUW DC Converter** is required to be provided with sub-synchronous resonance damping control facilities.
- (b) Where specified in the **Bilateral Agreement**, each **DC Converter** or **OTSDUW DC Converter** is required to be provided with power oscillation damping or any other identified additional control facilities.

#### System to Generator Operational Intertripping Scheme

CC.6.3.17 **NGET** may require that a **System to Generator Operational Intertripping Scheme** be installed as part of a condition of the connection of the **Generator**. Scheme specific details shall be included in the relevant **Bilateral Agreement** and shall, in respect of **Bilateral Agreements** entered into on or after 16<sup>th</sup> March 2009 include the following information:

- (1) the relevant category(ies) of the scheme (referred to as Category 1 Intertripping Scheme, Category 2 Intertripping Scheme, Category 3 Intertripping Scheme and Category 4 Intertripping Scheme);
- (2) the **Generating Unit(s)** or **CCGT Module(s)** or **Power Park Module(s)** to be either permanently armed or that can be instructed to be armed in accordance with BC2.8;
- (3) the time within which the **Generating Unit(s)** or **CCGT Module(s)** or **Power Park Module(s)** circuit breaker(s) are to be automatically tripped;
- (4) the location to which the trip signal will be provided by **NGET**. Such location will be provided by **NGET** prior to the commissioning of the **Generating Unit(s)** or **CCGT Module(s)** or **Power Park Module(s)**.

Where applicable, the **Bilateral Agreement** shall include the conditions on the **National Electricity Transmission System** during which **NGET** may instruct the **System to Generator Operational Intertripping Scheme** to be armed and the conditions that would initiate a trip signal.

CC.6.3.18 The time within which the **Generating Unit(s)** or **CCGT Module** or **Power Park Module** circuit breaker(s) need to be automatically tripped is determined by the specific conditions local to the **Generator**. This 'time to trip' (defined as time from provision of the trip signal by **NGET** to the specified location, to circuit breaker main contact opening) can typically range from 100ms to 10sec. A longer time to trip may allow the initiation of an automatic reduction in the **Generating Unit(s)** or **CCGT Module(s)** or **Power Park Module(s)** output prior to the automatic tripping of the **Generating Unit(s)** or **CCGT Module(s)** or **Power Park Module(s)** circuit breaker. Where applicable **NGET** may provide separate trip signals to allow for either a longer or shorter 'time to trip' to be initiated.

#### CC.6.4 General Network Operator And Non-Embedded Customer Requirements

CC.6.4.1 This part of the **Grid Code** describes the technical and design criteria and performance requirements for **Network Operators** and **Non-Embedded Customers**.

### Neutral Earthing

- CC.6.4.2 At nominal **System** voltages of 132kV and above the higher voltage windings of three phase transformers and transformer banks connected to the **National Electricity Transmission System** must be star connected with the star point suitable for connection to earth. The earthing and lower voltage winding arrangement shall be such as to ensure that the **Earth Fault Factor** requirement of paragraph CC.6.2.1.1 (b) will be met on the **National Electricity Transmission System** at nominal **System** voltages of 132kV and above.

### Frequency Sensitive Relays

- CC.6.4.3 As explained under **OC6**, each **Network Operator**, will make arrangements that will facilitate automatic low **Frequency Disconnection of Demand** (based on **Annual ACS Conditions**). CC.A.5.5. of Appendix 5 includes specifications of the local percentage **Demand** that shall be disconnected at specific frequencies. The manner in which **Demand** subject to low **Frequency** disconnection will be split into discrete MW blocks is specified in OC6.6. Technical requirements relating to **Low Frequency Relays** are also listed in Appendix 5.

### Operational Metering

- CC.6.4.4 Where **NGET** can reasonably demonstrate that an **Embedded Medium Power Station** or **Embedded DC Converter Station** has a significant effect on the **National Electricity Transmission System**, it may require the **Network Operator** within whose **System** the **Embedded Medium Power Station** or **Embedded DC Converter Station** is situated to ensure that the operational metering equipment described in CC.6.5.6 is installed such that **NGET** can receive the data referred to in CC.6.5.6. In the case of an **Embedded Medium Power Station** subject to, or proposed to be subject to a **Bilateral Agreement** **NGET** shall notify such **Network Operator** of the details of such installation in writing within 3 months of being notified of the application to connect under **CUSC** and in the case of an **Embedded Medium Power Station** not subject to, or not proposed to be subject to a **Bilateral Agreement** in writing as a **Site Specific Requirement** in accordance with the timescales in CUSC 6.5.5. In either case the **Network Operator** shall ensure that the data referred to in CC.6.5.6 is provided to **NGET**.

### CC.6.5 Communications Plant

- CC.6.5.1 In order to ensure control of the **National Electricity Transmission System**, telecommunications between **Users** and **NGET** must (including in respect of any **OTSDUW Plant and Apparatus** at the **OTSUA Transfer Time**), if required by **NGET**, be established in accordance with the requirements set down below.

### CC.6.5.2 Control Telephony and System Telephony

- CC.6.5.2.1 **Control Telephony** is the principle method by which a **User's Responsible Engineer/Operator** and **NGET Control Engineers** speak to one another for the purposes of control of the **Total System** in both normal and emergency operating conditions. **Control Telephony** provides secure point to point telephony for routine **Control Calls**, priority **Control Calls** and emergency **Control Calls**.

- CC.6.5.2.2 **System Telephony** is an alternate method by which a **User's Responsible Engineer/Operator** and **NGET Control Engineers** speak to one another for the purposes of control of the **Total System** in both normal operating conditions and where practicable, emergency operating conditions. **System Telephony** uses the Public Switched Telephony Network to provide telephony for **Control Calls**, inclusive of emergency **Control Calls**.



- CC.6.5.2.3 Calls made and received over **Control Telephony** and **System Telephony** may be recorded and subsequently replayed for commercial and operational reasons.
- CC.6.5.3 Supervisory Tones
- CC.6.5.3.1 **Control Telephony** supervisory tones indicate to the calling and receiving parties dial, engaged, ringing, secondary engaged (signifying that priority may be exercised) and priority disconnect tones.
- CC.6.5.3.2 **System Telephony** supervisory tones indicate to the calling and receiving parties dial, engaged and ringing tones.
- CC.6.5.4 Obligations in respect of Control Telephony and System Telephony
- CC.6.5.4.1 Where **NGET** requires **Control Telephony**, **Users** are required to use the **Control Telephony** with **NGET** in respect of all **Connection Points** with the **National Electricity Transmission System** and in respect of all **Embedded Large Power Stations** and **Embedded DC Converter Stations**. **NGET** will install **Control Telephony** at the **User's Control Point** where the **User's** telephony equipment is not capable of providing the required facilities or is otherwise incompatible with the **Transmission Control Telephony**. Details of and relating to the **Control Telephony** required are contained in the **Bilateral Agreement**.
- CC.6.5.4.2 Where in **NGET's** sole opinion the installation of **Control Telephony** is not practicable at a **User's Control Point(s)**, **NGET** shall specify in the **Bilateral Agreement** whether **System Telephony** is required. Where **System Telephony** is required by **NGET**, the **User** shall ensure that **System Telephony** is installed.
- CC.6.5.4.3 Where **System Telephony** is installed, **Users** are required to use the **System Telephony** with **NGET** in respect of those **Control Point(s)** for which it has been installed. Details of and relating to the **System Telephony** required are contained in the **Bilateral Agreement**.
- CC.6.5.4.4 Where **Control Telephony** or **System Telephony** is installed, routine testing of such facilities may be required by **NGET** (not normally more than once in any calendar month). The **User** and **NGET** shall use reasonable endeavours to agree a test programme and where **NGET** requests the assistance of the **User** in performing the agreed test programme the **User** shall provide such assistance.
- CC.6.5.4.5 **Control Telephony** and **System Telephony** shall only be used for the purposes of operational voice communication between **NGET** and the relevant **User**.
- CC.6.5.4.6 **Control Telephony** contains emergency calling functionality to be used for urgent operational communication only. Such functionality enables **NGET** and **Users** to utilise a priority call in the event of an emergency. **NGET** and **Users** shall only use such priority call functionality for urgent operational communications.
- CC.6.5.5 Technical Requirements for Control Telephony and System Telephony
- CC.6.5.5.1 Detailed information on the technical interfaces and support requirements for **Control Telephony** applicable in **NGET's Transmission Area** is provided in the **Control Telephony Electrical Standard** identified in the Annex to the **General Conditions**. Where additional information, or information in relation to **Control Telephony** applicable in Scotland, is requested by **Users**, this will be provided, where possible, by **NGET**.

CC.6.5.5.2 **System Telephony** shall consist of a dedicated Public Switched Telephone Network telephone line that shall be installed and configured by the relevant **User**. **NGET** shall provide a dedicated free phone number (UK only), for the purposes of receiving incoming calls to **NGET**, which **Users** shall utilise for **System Telephony**. **System Telephony** shall only be utilised by the **NGET Control Engineer** and the **User's Responsible Engineer/Operator** for the purposes of operational communications.

Operational Metering

- CC.6.5.6
- (a) **NGET** shall provide system control and data acquisition (SCADA) outstation interface equipment. The **User** shall provide such voltage, current, **Frequency**, **Active Power** and **Reactive Power** measurement outputs and plant status indications and alarms to the **Transmission SCADA** outstation interface equipment as required by **NGET** in accordance with the terms of the **Bilateral Agreement**. In the case of **OTSDUW**, the **User** shall provide such SCADA outstation interface equipment and voltage, current, **Frequency**, **Active Power** and **Reactive Power** measurement outputs and plant status indications and alarms to the SCADA outstation interface equipment as required by **NGET** in accordance with the terms of the **Bilateral Agreement**.
- (b) For the avoidance of doubt, for **Active Power** and **Reactive Power** measurements, circuit breaker and disconnector status indications from:
- (i) **CCGT Modules at Large Power Stations**, the outputs and status indications must each be provided to **NGET** on an individual **CCGT Unit** basis. In addition, where identified in the **Bilateral Agreement**, **Active Power** and **Reactive Power** measurements from **Unit Transformers** and/or **Station Transformers** must be provided.
  - (ii) **DC Converters at DC Converter Stations** and **OTSDUW DC Converters**, the outputs and status indications must each be provided to **NGET** on an individual **DC Converter** basis. In addition, where identified in the **Bilateral Agreement**, **Active Power** and **Reactive Power** measurements from converter and/or station transformers must be provided.
  - (iii) **Power Park Modules at Embedded Large Power Stations** and at directly connected **Power Stations**, the outputs and status indications must each be provided to **NGET** on an individual **Power Park Module** basis. In addition, where identified in the **Bilateral Agreement**, **Active Power** and **Reactive Power** measurements from station transformers must be provided.
  - (iv) In respect of **OTSDUW Plant and Apparatus**, the outputs and status indications must be provided to **NGET** for each piece of electrical equipment. In addition, where identified in the **Bilateral Agreement**, **Active Power** and **Reactive Power** measurements at the **Interface Point** must be provided.
- (c) For the avoidance of doubt, the requirements of CC.6.5.6(a) in the case of a **Cascade Hydro Scheme** will be provided for each **Generating Unit** forming part of that **Cascade Hydro Scheme**. In the case of **Embedded Generating Units** forming part of a **Cascade Hydro Scheme** the data may be provided by means other than a **NGET** SCADA outstation located at the **Power Station**, such as, with the agreement of the **Network Operator** in whose system such **Embedded Generating Unit** is located, from the **Network Operator's** SCADA system to **NGET**. Details of such arrangements will be contained in the relevant **Bilateral Agreements** between **NGET** and the **Generator** and the **Network Operator**.

- (d) In the case of a **Power Park Module** an additional energy input signal (e.g. wind speed) may be specified in the **Bilateral Agreement** . The signal may be used to establish the level of energy input from the **Intermittent Power Source** for monitoring pursuant to CC.6.6.1 and **Ancillary Services** and will, in the case of a wind farm, be used to provide **NGET** with advanced warning of excess wind speed shutdown.

Instructor Facilities

- CC.6.5.7 The **User** shall accommodate **Instructor Facilities** provided by **NGET** for the receipt of operational messages relating to **System** conditions.

Electronic Data Communication Facilities

- CC.6.5.8 (a) All **BM Participants** must ensure that appropriate electronic data communication facilities are in place to permit the submission of data, as required by the **Grid Code**, to **NGET**.

(b) In addition,

- (1) any **User** that wishes to participate in the **Balancing Mechanism**;

or

- (2) any **BM Participant** in respect of its **BM Units** at a **Power Station** where the **Construction Agreement** and/or a **Bilateral Agreement** has a **Completion Date** on or after 1 January 2013 and the **BM Participant** is required to provide all **Part 1 System Ancillary Services** in accordance with CC.8.1 (unless **NGET** has otherwise agreed)

must ensure that appropriate automatic logging devices are installed at the **Control Points** of its **BM Units** to submit data to and to receive instructions from **NGET**, as required by the **Grid Code**. For the avoidance of doubt, in the case of an **Interconnector User** the **Control Point** will be at the **Control Centre** of the appropriate **Externally Interconnected System Operator**.

- (c) Detailed specifications of these required electronic facilities will be provided by **NGET** on request and they are listed as **Electrical Standards** in the Annex to the **General Conditions**.

Facsimile Machines

- CC.6.5.9 Each **User** and **NGET** shall provide a facsimile machine or machines:

(a) in the case of **Generators**, at the **Control Point** of each **Power Station** and at its **Trading Point**;

(b) in the case of **NGET** and **Network Operators**, at the **Control Centre(s)**; and

(c) in the case of **Non-Embedded Customers** and **DC Converter Station** owners at the **Control Point**.

Each **User** shall notify, prior to connection to the **System** of the **User's Plant and Apparatus**, **NGET** of its or their telephone number or numbers, and will notify **NGET** of any changes. Prior to connection to the **System** of the **User's Plant and Apparatus** **NGET** shall notify each **User** of the telephone number or numbers of its facsimile machine or machines and will notify any changes.

- CC.6.5.10 Busbar Voltage

**NGET** shall, subject as provided below, provide each **Generator** or **DC Converter Station** owner at each **Grid Entry Point** where one of its **Power Stations** or **DC Converter Stations** is connected with appropriate voltage signals to enable the **Generator** or **DC Converter Station** owner to obtain the necessary information to permit its **Gensets** or **DC Converters** to be **Synchronised** to the **National Electricity Transmission System**. The term "**voltage signal**" shall mean in this context, a point of connection on (or wire or wires from) a relevant part of **Transmission Plant** and/or **Apparatus** at the **Grid Entry Point**, to which the **Generator** or **DC Converter Station** owner, with **NGET's** agreement (not to be unreasonably withheld) in relation to the **Plant** and/or **Apparatus** to be attached, will be able to attach its **Plant** and/or **Apparatus** (normally a wire or wires) in order to obtain measurement outputs in relation to the busbar.

CC.6.5.11

Bilingual Message Facilities

- (a) A Bilingual Message Facility is the method by which the **User's Responsible Engineer/Operator**, the **Externally Interconnected System Operator** and **NGET Control Engineers** communicate clear and unambiguous information in two languages for the purposes of control of the **Total System** in both normal and emergency operating conditions.
- (b) A Bilingual Message Facility, where required, will provide up to two hundred pre-defined messages with up to five hundred and sixty characters each. A maximum of one minute is allowed for the transmission to, and display of, the selected message at any destination. The standard messages must be capable of being displayed at any combination of locations and can originate from any of these locations. Messages displayed in the UK will be displayed in the English language.
- (c) Detailed information on a Bilingual Message Facility and suitable equipment required for individual **User** applications will be provided by **NGET** upon request.

- CC.6.6 System Monitoring
- CC.6.6.1 Monitoring equipment is provided on the **National Electricity Transmission System** to enable **NGET** to monitor its power system dynamic performance conditions. Where this monitoring equipment requires voltage and current signals on the **Generating Unit** (other than **Power Park Unit**), **DC Converter** or **Power Park Module** circuit from the **User** or from **OTSDUW Plant and Apparatus**, **NGET** will inform the **User** and they will be provided by the **User** with both the timing of the installation of the equipment for receiving such signals and its exact position being agreed (the **User's** agreement not to be unreasonably withheld) and the costs being dealt with, pursuant to the terms of the **Bilateral Agreement**.
- CC.6.6.2 For all on site monitoring by **NGET** of witnessed tests pursuant to the **CP** or **OC5** the **User** shall provide suitable test signals as outlined in OC5.A.1.
- CC.6.6.2.1 The signals which shall be provided by the **User** to **NGET** for onsite monitoring shall be of the following resolution, unless otherwise agreed by **NGET**:
- (i) 1 Hz for reactive range tests
  - (ii) 10 Hz for frequency control tests
  - (iii) 100 Hz for voltage control tests
- CC.6.6.2.2 The **User** will provide all relevant signals for this purpose in the form of d.c. voltages within the range -10V to +10V. In exceptional circumstances some signals may be accepted as d.c. voltages within the range -60V to +60V with prior agreement between the **User** and **NGET**. All signals shall:
- (i) in the case of an **Onshore Power Park Module, DC Converter Station** or **Synchronous Generating Unit**, be suitably terminated in a single accessible location at the **Generator** or **DC Converter Station** owner's site.
  - (ii) in the case of an **Offshore Power Park Module** and **OTSDUW Plant and Apparatus**, be transmitted onshore without attenuation, delay or filtering which would result in the inability to fully demonstrate the objectives of the test, or identify any potential safety or plant instability issues, and be suitably terminated in a single robust location normally located at or near the onshore **Interface Point** of the **Offshore Transmission System** to which it is connected.
- CC.6.6.2.3 All signals shall be suitably scaled across the range. The following scaling would (unless **NGET** notify the **User** otherwise) be acceptable to **NGET**:
- (a) 0MW to **Registered Capacity** or **Interface Point Capacity** 0-8V dc
  - (b) Maximum leading **Reactive Power** to maximum lagging **Reactive Power** -8 to 8V dc
  - (c) 48 – 52Hz as -8 to 8V dc
  - (d) Nominal terminal or connection point voltage -10% to +10% as -8 to 8V dc
- CC.6.6.2.4 The **User** shall provide to **NGET** a 230V power supply adjacent to the signal terminal location.
- CC.7 SITE RELATED CONDITIONS
- CC.7.1 Not used.
- CC.7.2 Responsibilities For Safety

CC.7.2.1 In England and Wales, any **User** entering and working on its **Plant** and/or **Apparatus** (including, until the OTSUA Transfer Time, any OTSUA) on a **Transmission Site** will work to the **Safety Rules** of **NGET**.

In Scotland or **Offshore**, any **User** entering and working on its **Plant** and/or **Apparatus** (including, until the OTSUA Transfer Time, any OTSUA) on a **Transmission Site** will work to the **Safety Rules** of the **Relevant Transmission Licensee**, as advised by **NGET**.

CC.7.2.2 **NGET** entering and working on **Transmission Plant** and/or **Apparatus** on a **User Site** will work to the **User's Safety Rules**. For **User Sites** in Scotland or **Offshore**, **NGET** shall procure that the **Relevant Transmission Licensee** entering and working on **Transmission Plant** and/or **Apparatus** on a **User Site** will work to the **User's Safety Rules**.

CC.7.2.3 A **User** may, with a minimum of six weeks notice, apply to **NGET** for permission to work according to that **Users** own **Safety Rules** when working on its **Plant** and/or **Apparatus** on a **Transmission Site** rather than those set out in CC.7.2.1. If **NGET** is of the opinion that the **User's Safety Rules** provide for a level of safety commensurate with those set out in CC.7.2.1, **NGET** will notify the **User**, in writing, that, with effect from the date requested by the **User**, the **User** may use its own **Safety Rules** when working on its **Plant** and/or **Apparatus** on the **Transmission Site**. For a **Transmission Site** in Scotland or **Offshore**, in forming its opinion, **NGET** will seek the opinion of the **Relevant Transmission Licensee**. Until receipt of such written approval from **NGET**, the **User** will continue to use the **Safety Rules** as set out in CC.7.2.1.

CC.7.2.4 In the case of a **User Site** in England and Wales, **NGET** may, with a minimum of six weeks notice, apply to a **User** for permission to work according to **NGET's Safety Rules** when working on **Transmission Plant** and/or **Apparatus** on that **User Site**, rather than the **User's Safety Rules**. If the **User** is of the opinion that **NGET's Safety Rules** provide for a level of safety commensurate with that of that **User's Safety Rules**, it will notify **NGET**, in writing, that, with the effect from the date requested by **NGET**, **NGET** may use its own **Safety Rules** when working on its **Transmission Plant** and/or **Apparatus** on that **User Site**. Until receipt of such written approval from the **User**, **NGET** shall continue to use the **User's Safety Rules**.

In the case of a **User Site** in Scotland or **Offshore**, **NGET** may, with a minimum of six weeks notice, apply to a **User** for permission for the **Relevant Transmission Licensee** to work according to the **Relevant Transmission Licensee's Safety Rules** when working on **Transmission Plant** and/or **Apparatus** on that **User Site**, rather than the **User's Safety Rules**. If the **User** is of the opinion that the **Relevant Transmission Licensee's Safety Rules**, provide for a level of safety commensurate with that of that **User's Safety Rules**, it will notify **NGET**, in writing, that, with effect from the date requested by **NGET**, that the **Relevant Transmission Licensee** may use its own **Safety Rules** when working on its **Transmission Plant** and/or **Apparatus** on that **User's Site**. Until receipt of such written approval from the **User**, **NGET** shall procure that the **Relevant Transmission Licensee** shall continue to use the **User's Safety Rules**.

CC.7.2.5 For a **Transmission Site** in England and Wales, if **NGET** gives its approval for the **User's Safety Rules** to apply to the **User** when working on its **Plant** and/or **Apparatus**, that does not imply that the **User's Safety Rules** will apply to entering the **Transmission Site** and access to the **User's Plant** and/or **Apparatus** on that **Transmission Site**. Bearing in mind **NGET's** responsibility for the whole **Transmission Site**, entry and access will always be in accordance with **NGET's** site access procedures. For a **User Site** in England and Wales, if the **User** gives its approval for **NGET's Safety Rules** to apply to **NGET** when working on its **Plant** and **Apparatus**, that does not imply that **NGET's Safety Rules** will apply to entering the **User Site**, and access to the **Transmission Plant** and **Apparatus** on that **User Site**. Bearing in mind the **User's** responsibility for the whole **User Site**, entry and access will always be in accordance with the **User's** site access procedures.

For a **Transmission Site** in Scotland or **Offshore**, if **NGET** gives its approval for the **User's Safety Rules** to apply to the **User** when working on its **Plant** and/or **Apparatus**, that does not imply that the **User's Safety Rules** will apply to entering the **Transmission Site** and access to the **User's Plant** and/or **Apparatus** on that **Transmission Site**. Bearing in mind the **Relevant Transmission Licensee's** responsibility for the whole **Transmission Site**, entry and access will always be in accordance with the **Relevant Transmission Licensee's** site access procedures. For a **User Site** in Scotland or **Offshore**, if the **User** gives its approval for **Relevant Transmission Licensee Safety Rules** to apply to the **Relevant Transmission Licensee** when working on its **Plant** and **Apparatus**, that does not imply that the **Relevant Transmission Licensee's Safety Rules** will apply to entering the **User Site**, and access to the **Transmission Plant** and **Apparatus** on that **User Site**. Bearing in mind the **User's** responsibility for the whole **User Site**, entry and access will always be in accordance with the **User's** site access procedures.

CC.7.2.6 For **User Sites** in England and Wales, **Users** shall notify **NGET** of any **Safety Rules** that apply to **NGET's** staff working on **User Sites**. For **Transmission Sites** in England and Wales, **NGET** shall notify **Users** of any **Safety Rules** that apply to the **User's** staff working on the **Transmission Site**.

For **User Sites** in Scotland or **Offshore**, **Users** shall notify **NGET** of any **Safety Rules** that apply to the **Relevant Transmission Licensee's** staff working on **User Sites**. For **Transmission Sites** in Scotland or **Offshore** **NGET** shall procure that the **Relevant Transmission Licensee** shall notify **Users** of any **Safety Rules** that apply to the **User's** staff working on the **Transmission Site**.

CC.7.2.7 Each **Site Responsibility Schedule** must have recorded on it the **Safety Rules** which apply to each item of **Plant** and/or **Apparatus**.

CC.7.2.8 In the case of **OTSUA** a **User Site** or **Transmission Site** shall, for the purposes of this CC.7.2, include a site at which there is an **Interface Point** until the **OTSUA Transfer Time when it** becomes part of the **National Electricity Transmission System** ~~as an Offshore Transmission System~~.

CC.7.3 Site Responsibility Schedules

CC.7.3.1 In order to inform site operational staff and **NGET Control Engineers** of agreed responsibilities for **Plant** and/or **Apparatus** at the operational interface, a **Site Responsibility Schedule** shall be produced for **Connection Sites** (and in the case of OTSUA, until the OTSUA Transfer Time, Interface Sites) in England and Wales for **NGET** and **Users** with whom they interface, and for **Connection Sites** (and in the case of OTSUA, until the OTSUA Transfer Time, Interface Sites) in Scotland or **Offshore** for **NGET**, the **Relevant Transmission Licensee** and **Users** with whom they interface.

- CC.7.3.2 The format, principles and basic procedure to be used in the preparation of **Site Responsibility Schedules** are set down in Appendix 1.
- CC.7.4 Operation And Gas Zone Diagrams  
Operation Diagrams
- CC.7.4.1 An **Operation Diagram** shall be prepared for each **Connection Site** at which a **Connection Point** exists (and in the case of **OTSDUW Plant and Apparatus**, by **User's** for each **Interface Point**) using, where appropriate, the graphical symbols shown in Part 1A of Appendix 2. **Users** should also note that the provisions of **OC11** apply in certain circumstances.
- CC.7.4.2 The **Operation Diagram** shall include all **HV Apparatus** and the connections to all external circuits and incorporate numbering, nomenclature and labelling, as set out in **OC11**. At those **Connection Sites** (or in the case of **OTSDUW Plant and Apparatus, Interface Points**) where gas-insulated metal enclosed switchgear and/or other gas-insulated **HV Apparatus** is installed, those items must be depicted within an area delineated by a chain dotted line which intersects gas-zone boundaries. The nomenclature used shall conform with that used on the relevant **Connection Site** and circuit (and in the case of **OTSDUW Plant and Apparatus, Interface Point** and circuit). The **Operation Diagram** (and the list of technical details) is intended to provide an accurate record of the layout and circuit interconnections, ratings and numbering and nomenclature of **HV Apparatus** and related **Plant**.
- CC.7.4.3 A non-exhaustive guide to the types of **HV Apparatus** to be shown in the **Operation Diagram** is shown in Part 2 of Appendix 2, together with certain basic principles to be followed unless equivalent principles are approved by **NGET**.
- Gas Zone Diagrams
- CC.7.4.4 A **Gas Zone Diagram** shall be prepared for each **Connection Site** at which a **Connection Point** (and in the case of **OTSDUW Plant and Apparatus**, by **User's** for an **Interface Point**) exists where gas-insulated switchgear and/or other gas-insulated **HV Apparatus** is utilised. They shall use, where appropriate, the graphical symbols shown in Part 1B of Appendix 2.
- CC.7.4.5 The nomenclature used shall conform with that used in the relevant **Connection Site** and circuit (and in the case of **OTSDUW Plant and Apparatus**, relevant **Interface Point** and circuit).
- CC.7.4.6 The basic principles set out in Part 2 of Appendix 2 shall be followed in the preparation of **Gas Zone Diagrams** unless equivalent principles are approved by **NGET**.
- Preparation of Operation and Gas Zone Diagrams for Users' Sites and Transmission Interface Sites
- CC.7.4.7 In the case of a **User Site**, the **User** shall prepare and submit to **NGET**, an **Operation Diagram** for all **HV Apparatus** on the **User** side of the **Connection Point** (and in the case of **OTSDUW Plant and Apparatus**, on what will be the **Offshore Transmission** side of the **Connection Point** and the **Interface Point**) and **NGET** shall provide the **User** with an **Operation Diagram** for all **HV Apparatus** on the **Transmission** side of the **Connection Point** (and in the case of **OTSDUW Plant and Apparatus** on what will be the **Onshore Transmission** side of the **Interface Point**, in accordance with the timing requirements of the **Bilateral Agreement** and/or **Construction Agreement** prior to the **Completion Date** under the **Bilateral Agreement** and/or **Construction Agreement**.



CC.7.4.8 The **User** will then prepare, produce and distribute, using the information submitted on the **User's Operation Diagram** and **NGET Operation Diagram**, a composite **Operation Diagram** for the complete **Connection Site** (and in the case of **OTSDUW Plant and Apparatus, Interface Point**), also in accordance with the timing requirements of the **Bilateral Agreement** and/or **Construction Agreement** .

CC.7.4.9 The provisions of CC.7.4.7 and CC.7.4.8 shall apply in relation to **Gas Zone Diagrams** where gas-insulated switchgear and/or other gas-insulated **HV Apparatus** is utilised.

Preparation of Operation and Gas Zone Diagrams for Transmission Sites

CC.7.4.10 In the case of an **Transmission Site**, the **User** shall prepare and submit to **NGET** an **Operation Diagram** for all **HV Apparatus** on the **User** side of the **Connection Point**, in accordance with the timing requirements of the **Bilateral Agreement** and/or **Construction Agreement**.

CC.7.4.11 **NGET** will then prepare, produce and distribute, using the information submitted on the **User's Operation Diagram**, a composite **Operation Diagram** for the complete **Connection Site**, also in accordance with the timing requirements of the **Bilateral Agreement** and/or **Construction Agreement** .

CC.7.4.12 The provisions of CC.7.4.10 and CC.7.4.11 shall apply in relation to **Gas Zone Diagrams** where gas-insulated switchgear and/or other gas-insulated **HV Apparatus** is utilised.

Changes to Operation and Gas Zone Diagrams

CC.7.4.13.1 When **NGET** has decided that it wishes to install new **HV Apparatus** or it wishes to change the existing numbering or nomenclature of **Transmission HV Apparatus** at a **Transmission Site**, **NGET** will (unless it gives rise to a **Modification** under the **CUSC**, in which case the provisions of the **CUSC** as to the timing apply) one month prior to the installation or change, send to each such **User** a revised **Operation Diagram** of that **Transmission Site**, incorporating the new **Transmission HV Apparatus** to be installed and its numbering and nomenclature or the changes, as the case may be. **OC11** is also relevant to certain **Apparatus**.

CC.7.4.13.2 When a **User** has decided that it wishes to install new **HV Apparatus**, or it wishes to change the existing numbering or nomenclature of its **HV Apparatus** at its **User Site**, the **User** will (unless it gives rise to a **Modification** under the **CUSC**, in which case the provisions of the **CUSC** as to the timing apply) one month prior to the installation or change, send to **NGET** a revised **Operation Diagram** of that **User Site** incorporating the new **User HV Apparatus** to be installed and its numbering and nomenclature or the changes as the case may be. **OC11** is also relevant to certain **Apparatus**.

CC.7.4.13.3 The provisions of CC.7.4.13.1 and CC.7.4.13.2 shall apply in relation to **Gas Zone Diagrams** where gas-insulated switchgear and/or other gas-insulated **HV Apparatus** is installed.

Validity

CC.7.4.14 (a) The composite **Operation Diagram** prepared by **NGET** or the **User**, as the case may be, will be the definitive **Operation Diagram** for all operational and planning activities associated with the **Connection Site**. If a dispute arises as to the accuracy of the composite **Operation Diagram**, a meeting shall be held at the **Connection Site**, as soon as reasonably practicable, between **NGET** and the **User**, to endeavour to resolve the matters in dispute.

- (b) The composite **Operation Diagram** prepared by **NGET** or the **User**, as the case may be, will be the definitive **Operation Diagram** for all operational and planning activities associated with the **Interface Point** until the **OTSUA Transfer Time**. If a dispute arises as to the accuracy of the composite **Operation Diagram** prior to the **OTSUA Transfer Time**, a meeting shall be held at the **Interface Point**, as soon as reasonably practicable, between **NGET** and the **User**, to endeavour to resolve the matters in dispute.
- (c) An equivalent rule shall apply for **Gas Zone Diagrams** where they exist for a **Connection Site**.

CC.7.4.15 In the case of **OTSUA**, a **User Site** and **Transmission Site** shall, for the purposes of this CC.7.4, include a site at which there is an **Interface Point** until the **OTSUA Transfer Time when it** becomes part of the **National Electricity Transmission System** ~~as an Offshore Transmission System~~ and references to **HV Apparatus** in this CC.7.4 shall include references to **HV OTSUA**.

CC.7.5 Site Common Drawings

CC.7.5.1 **Site Common Drawings** will be prepared for each **Connection Site** (and in the case of **OTSDUW**, each **Interface Point**) and will include **Connection Site** (and in the case of **OTSDUW**, **Interface Point**) layout drawings, electrical layout drawings, common **Protection/control** drawings and common services drawings.

Preparation of Site Common Drawings for a User Site and Transmission Interface Site

CC.7.5.2 In the case of a **User Site**, **NGET** shall prepare and submit to the **User**, **Site Common Drawings** for the **Transmission** side of the **Connection Point** (and in the case of **OTSDUW Plant and Apparatus**, on what will be the **Onshore Transmission** side of the **Interface Point**.) and the **User** shall prepare and submit to **NGET**, **Site Common Drawings** for the **User** side of the **Connection Point** (and in the case of **OTSDUW**, on what will be the **Offshore Transmission** side of the **Interface Point**) in accordance with the timing requirements of the **Bilateral Agreement** and/or **Construction Agreement**.

CC.7.5.3 The **User** will then prepare, produce and distribute, using the information submitted on the **Transmission Site Common Drawings**, **Site Common Drawings** for the complete **Connection Site** (and in the case of **OTSDUW**, **Interface Point**) in accordance with the timing requirements of the **Bilateral Agreement** and/or **Construction Agreement**.

Preparation of Site Common Drawings for a Transmission Site

CC.7.5.4 In the case of a **Transmission Site**, the **User** will prepare and submit to **NGET Site Common Drawings** for the **User** side of the **Connection Point** in accordance with the timing requirements of the **Bilateral Agreement** and/or **Construction Agreement**.

CC.7.5.5 **NGET** will then prepare, produce and distribute, using the information submitted in the **User's Site Common Drawings**, **Site Common Drawings** for the complete **Connection Site** in accordance with the timing requirements of the **Bilateral Agreement** and/or **Construction Agreement**.

CC.7.5.6 When a **User** becomes aware that it is necessary to change any aspect of the **Site Common Drawings** at a **Connection Site** (and in the case of **OTSDUW**, **Interface Point**) it will:

- (a) if it is a **User Site**, as soon as reasonably practicable, prepare, produce and distribute revised **Site Common Drawings** for the complete **Connection Site** (and in the case of **OTSDUW**, **Interface Point**); and

- (b) if it is a **Transmission Site**, as soon as reasonably practicable, prepare and submit to **NGET** revised **Site Common Drawings** for the **User** side of the **Connection Point** (and in the case of **OTSDUW, Interface Point**) and **NGET** will then, as soon as reasonably practicable, prepare, produce and distribute, using the information submitted in the **User's Site Common Drawings**, revised **Site Common Drawings** for the complete **Connection Site** (and in the case of **OTSDUW, Interface Point**).

In either case, if in the **User's** reasonable opinion the change can be dealt with by it notifying **NGET** in writing of the change and for each party to amend its copy of the **Site Common Drawings** (or where there is only one set, for the party holding that set to amend it), then it shall so notify and each party shall so amend. If the change gives rise to a **Modification** under the **CUSC**, the provisions of the **CUSC** as to timing will apply.

CC.7.5.7

When **NGET** becomes aware that it is necessary to change any aspect of the **Site Common Drawings** at a **Connection Site**(and in the case of **OTSDUW, Interface Point**) it will:

- (a) if it is a **Transmission Site**, as soon as reasonably practicable, prepare, produce and distribute revised **Site Common Drawings** for the complete **Connection Site** (and in the case of **OTSDUW, Interface Point**); and
- (b) if it is a **User Site**, as soon as reasonably practicable, prepare and submit to the **User** revised **Site Common Drawings** for the **Transmission** side of the **Connection Point** (in the case of **OTSDUW, Interface Point**) and the **User** will then, as soon as reasonably practicable, prepare, produce and distribute, using the information submitted in the **Transmission Site Common Drawings**, revised **Site Common Drawings** for the complete **Connection Site** (and in the case of **OTSDUW, Interface Point**).

In either case, if in **NGET's** reasonable opinion the change can be dealt with by it notifying the **User** in writing of the change and for each party to amend its copy of the **Site Common Drawings** (or where there is only one set, for the party holding that set to amend it), then it shall so notify and each party shall so amend. If the change gives rise to a **Modification** under the **CUSC**, the provisions of the **CUSC** as to timing will apply.

#### Validity

CC.7.5.8

- (a) The **Site Common Drawings** for the complete **Connection Site** prepared by the **User** or **NGET**, as the case may be, will be the definitive **Site Common Drawings** for all operational and planning activities associated with the **Connection Site**. If a dispute arises as to the accuracy of the **Site Common Drawings**, a meeting shall be held at the **Site**, as soon as reasonably practicable, between **NGET** and the **User**, to endeavour to resolve the matters in dispute.
- (b) The **Site Common Drawing** prepared by **NGET** or the **User**, as the case may be, will be the definitive **Site Common Drawing** for all operational and planning activities associated with the **Interface Point** until the **OTSUA Transfer Time**. If a dispute arises as to the accuracy of the composite **Operation Diagram** prior to the **OTSUA Transfer Time**, a meeting shall be held at the **Interface Point**, as soon as reasonably practicable, between **NGET** and the **User**, to endeavour to resolve the matters in dispute.

CC.7.5.9

In the case of **OTSUA**, a **User Site** and **Transmission Site** shall, for the purposes of this CC.7.5, include a site at which there is an **Interface Point** until the **OTSUA Transfer Time when it** becomes part of the **National Electricity Transmission System as an Offshore Transmission System**.

- CC.7.6 Access
- CC.7.6.1 The provisions relating to access to **Transmission Sites** by **Users**, and to **Users' Sites** by **Transmission Licensees**, are set out in each **Interface Agreement (or in the case of Interfaces Sites prior to the OTSUA Transfer Time agreements in similar form)** with, for **Transmission Sites** in England and Wales, **NGET** and each **User**, and for **Transmission Sites** in Scotland and **Offshore**, the **Relevant Transmission Licensee** and each **User**.
- CC.7.6.2 In addition to those provisions, where a **Transmission Site** in England and Wales contains exposed **HV** conductors, unaccompanied access will only be granted to individuals holding an **Authority for Access** issued by **NGET** and where a **Transmission Site** in Scotland or **Offshore** contains exposed **HV** conductors, unaccompanied access will only be granted to individuals holding an **Authority for Access** issued by the **Relevant Transmission Licensee**.
- CC.7.6.3 The procedure for applying for an **Authority for Access** is contained in the **Interface Agreement**.
- CC.7.7 Maintenance Standards
- CC.7.7.1 It is the **User's** responsibility to ensure that all its **Plant** and **Apparatus (including, until the OTSUA Transfer Time, any OTSUA)** on a **Transmission Site** is tested and maintained adequately for the purpose for which it is intended, and to ensure that it does not pose a threat to the safety of any **Transmission Plant, Apparatus** or personnel on the **Transmission Site**. **NGET** will have the right to inspect the test results and maintenance records relating to such **Plant** and **Apparatus** at any time
- CC.7.7.2 For **User Sites** in England and Wales, **NGET** has a responsibility to ensure that all **Transmission Plant** and **Apparatus** on a **User Site** is tested and maintained adequately for the purposes for which it is intended and to ensure that it does not pose a threat to the safety of any **User's Plant, Apparatus** or personnel on the **User Site**.
- For **User Sites** in Scotland and **Offshore**, **NGET** shall procure that the **Relevant Transmission Licensee** has a responsibility to ensure that all **Transmission Plant** and **Apparatus** on a **User Site** is tested and maintained adequately for the purposes for which it is intended and to ensure that it does not pose a threat to the safety of any **User's Plant, Apparatus** or personnel on the **User Site**.
- The **User** will have the right to inspect the test results and maintenance records relating to such **Plant** and **Apparatus** on its **User Site** at any time.
- CC.7.8 Site Operational Procedures
- CC.7.8.1 **NGET** and **Users** with an interface with **NGET**, must make available staff to take necessary **Safety Precautions** and carry out operational duties as may be required to enable work/testing to be carried out and for the operation of **Plant** and **Apparatus (including, prior to the OTSUA Transfer Time, any OTSUA) connected** to the **Total System**.
- CC.7.9 **Generators** and **DC Converter Station** owners shall provide a **Control Point** in respect of each **Power Station** directly connected to the **National Electricity Transmission System** and **Embedded Large Power Station** or **DC Converter Station** to receive an act upon instructions pursuant to OC7 and BC2 at all times that **Generating Units** or **Power Park Modules** at the **Power Station** are generating or available to generate or **DC Converters** at the **DC Converter Station** are importing or exporting or available to do so. The **Control Point** shall be continuously manned except where the **Bilateral Agreement** in respect of such **Embedded Power Station** specifies that compliance with BC2 is not required, where the **Control Point** shall be manned between the hours of 0800 and 1800 each day.

CC.8 ANCILLARY SERVICES

CC.8.1 System Ancillary Services

The **CC** contain requirements for the capability for certain **Ancillary Services**, which are needed for **System** reasons ("**System Ancillary Services**"). There follows a list of these **System Ancillary Services**, together with the paragraph number of the **CC** (or other part of the **Grid Code**) in which the minimum capability is required or referred to. The list is divided into two categories: Part 1 lists the **System Ancillary Services** which

- (a) **Generators** in respect of **Large Power Stations** are obliged to provide (except **Generators** in respect of **Large Power Stations** which have a **Registered Capacity** of less than 50MW and comprise **Power Park Modules**); and,
- (b) **Generators** in respect of **Large Power Stations** with a **Registered Capacity** of less than 50MW and comprise **Power Park Modules** are obliged to provide in respect of **Reactive Power** only; and,
- (c) **DC Converter Station** owners are obliged to have the capability to supply; and
- (d) **Generators** in respect of **Medium Power Stations** (except **Embedded Medium Power Stations**) are obliged to provide in respect of **Reactive Power** only:

and Part 2 lists the **System Ancillary Services** which **Generators** will provide only if agreement to provide them is reached with **NGET**:

Part 1

- (a) **Reactive Power** supplied (in accordance with CC.6.3.2) otherwise than by means of synchronous or static compensators (except in the case of a **Power Park Module** where synchronous or static compensators within the **Power Park Module** may be used to provide **Reactive Power**)
- (b) **Frequency** Control by means of **Frequency** sensitive generation - CC.6.3.7 and BC3.5.1

Part 2

- (c) **Frequency** Control by means of **Fast Start** - CC.6.3.14
- (d) **Black Start Capability** - CC.6.3.5
- (e) **System to Generator Operational Intertripping**

CC.8.2 Commercial Ancillary Services

Other **Ancillary Services** are also utilised by **NGET** in operating the **Total System** if these have been agreed to be provided by a **User** (or other person) under an **Ancillary Services Agreement** or under a **Bilateral Agreement**, with payment being dealt with under an **Ancillary Services Agreement** or in the case of **Externally Interconnected System Operators** or **Interconnector Users**, under any other agreement (and in the case of **Externally Interconnected System Operators** and **Interconnector Users** includes ancillary services equivalent to or similar to **System Ancillary Services**) ("**Commercial Ancillary Services**"). The capability for these **Commercial Ancillary Services** is set out in the relevant **Ancillary Services Agreement** or **Bilateral Agreement** (as the case may be).

## APPENDIX 1 - SITE RESPONSIBILITY SCHEDULES

### FORMAT, PRINCIPLES AND BASIC PROCEDURE TO BE USED IN THE PREPARATION OF SITE RESPONSIBILITY SCHEDULES

- CC.A.1.1 Principles
- Types of Schedules
- CC.A.1.1.1 At all **Complexes** (which in the context of this CC shall include, **Interface Sites until the OTSUA Transfer Time**) the following **Site Responsibility Schedules** shall be drawn up using the relevant proforma attached or with such variations as may be agreed between **NGET** and **Users**, but in the absence of agreement the relevant proforma attached will be used. In addition, in the case of **OTSDUW Plant and Apparatus, and in readiness for the OTSUA Transfer Time**, the **User** shall provide **NGET** with the necessary information such that **Site Responsibility Schedules** in this form can be prepared by the **Relevant Transmission Licensees** for the **Transmission Interface Site**:
- (a) **Schedule of HV Apparatus**
  - (b) **Schedule of Plant, LV/MV Apparatus**, services and supplies;
  - (c) **Schedule of telecommunications and measurements Apparatus.**
- Other than at **Generating Unit, DC Converter, Power Park Module** and **Power Station** locations, the schedules referred to in (b) and (c) may be combined.
- New Connection Sites
- CC.A.1.1.2 In the case of a new **Connection Site** each **Site Responsibility Schedule** for a **Connection Site** shall be prepared by **NGET** in consultation with relevant **Users** at least 2 weeks prior to the **Completion Date** (or, where the **OTSUA is to become Operational prior to the OTSUA Transfer Time, an alternative date**) under the **Bilateral Agreement** and/or **Construction Agreement** for that **Connection Site** (which may form part of a **Complex**). In the case of a new **Interface Site** where the **OTSUA is to become Operational prior to the OTSUA Transfer Time** each **Site Responsibility Schedule** for an **Interface Site** shall be prepared by **NGET** in consultation with relevant **Users** at least 2 weeks prior to the **Completion Date** under the **Bilateral Agreement** and/or **Construction Agreement** for that **Interface Site** (which may form part of a **Complex**) (and references to and requirements placed on "**Connection Site**" in this CC shall also be read as "**Interface Site**" where the context requires and until the **OTSUA Transfer Time**). Each **User** shall, in accordance with the timing requirements of the **Bilateral Agreement** and/or **Construction Agreement**, provide information to **NGET** to enable it to prepare the **Site Responsibility Schedule**.
- Sub-division
- CC.A.1.1.3 Each **Site Responsibility Schedule** will be subdivided to take account of any separate **Connection Sites** on that **Complex**.
- Scope
- CC.A.1.1.4 Each **Site Responsibility Schedule** shall detail for each item of **Plant** and **Apparatus**:
- (a) **Plant/Apparatus** ownership;
  - (b) **Site Manager (Controller)** (except in the case of **Plant/Apparatus** located in **SPT's Transmission Area**);

- (c) Safety issues comprising applicable **Safety Rules** and **Control Person** or other responsible person (**Safety Co-ordinator**), or such other person who is responsible for safety;
- (d) Operations issues comprising applicable **Operational Procedures** and control engineer;
- (e) Responsibility to undertake statutory inspections, fault investigation and maintenance.

Each **Connection Point** shall be precisely shown.

### Detail

- CC.A.1.1.5 (a) In the case of **Site Responsibility Schedules** referred to in CC.A.1.1.1(b) and (c), with the exception of **Protection Apparatus** and **Intertrip Apparatus** operation, it will be sufficient to indicate the responsible **User** or **Transmission Licensee**, as the case may be.
- (b) In the case of the **Site Responsibility Schedule** referred to in CC.A.1.1.1(a) and for **Protection Apparatus** and **Intertrip Apparatus**, the responsible management unit must be shown in addition to the **User** or **Transmission Licensee**, as the case may be.

CC.A.1.1.6 The **HV Apparatus Site Responsibility Schedule** for each **Connection Site** must include lines and cables emanating from or traversing<sup>1</sup> the **Connection Site**.

### Issue Details

CC.A.1.1.7 Every page of each **Site Responsibility Schedule** shall bear the date of issue and the issue number.

### Accuracy Confirmation

CC.A.1.1.8 When a **Site Responsibility Schedule** is prepared it shall be sent by **NGET** to the **Users** involved for confirmation of its accuracy.

CC.A.1.1.9 The **Site Responsibility Schedule** shall then be signed on behalf of **NGET** by its **Responsible Manager** (see CC.A.1.1.16) and on behalf of each **User** involved by its **Responsible Manager** (see CC.A.1.1.16), by way of written confirmation of its accuracy. For **Connection Sites** in Scotland or **Offshore**, the **Site Responsibility Schedule** will also be signed on behalf of the **Relevant Transmission Licensee** by its **Responsible Manager**.

### Distribution and Availability

CC.A.1.1.10 Once signed, two copies will be distributed by **NGET**, not less than two weeks prior to its implementation date, to each **User** which is a party on the **Site Responsibility Schedule**, accompanied by a note indicating the issue number and the date of implementation.

CC.A.1.1.11 **NGET** and **Users** must make the **Site Responsibility Schedules** readily available to operational staff at the **Complex** and at the other relevant control points.

### Alterations to Existing Site Responsibility Schedules

CC.A.1.1.12 Without prejudice to the provisions of CC.A.1.1.15 which deals with urgent changes, when a **User** identified on a **Site Responsibility Schedule** becomes aware that an alteration is necessary, it must inform **NGET** immediately and in any event 8 weeks prior to any change taking effect (or as soon as possible after becoming aware of it, if less than 8 weeks remain when the **User** becomes aware of the change). This will cover the commissioning of new **Plant** and/or **Apparatus** at the **Connection Site**, whether requiring a revised **Bilateral Agreement** or not, de-commissioning of **Plant** and/or **Apparatus**, and other changes which affect the accuracy of the **Site Responsibility Schedule**.

CC.A.1.1.13 Where **NGET** has been informed of a change by a **User**, or itself proposes a change, it will prepare a revised **Site Responsibility Schedule** by not less than six weeks prior to the change taking effect (subject to it having been informed or knowing of the change eight weeks prior to that time) and the procedure set out in CC.A.1.1.8 shall be followed with regard to the revised **Site Responsibility Schedule**.

---

<sup>1</sup> Details of circuits traversing the **Connection Site** are only needed from the date which is the earlier of the date when the **Site Responsibility Schedule** is first updated and 15<sup>th</sup> October 2004. In Scotland or **Offshore**, from a date to be agreed between **NGET** and the **Relevant Transmission Licensee**.



CC.A 1.1.14 The revised **Site Responsibility Schedule** shall then be signed in accordance with the procedure set out in CC.A.1.1.9 and distributed in accordance with the procedure set out in CC.A.1.1.10, accompanied by a note indicating where the alteration(s) has/have been made, the new issue number and the date of implementation.

#### Urgent Changes

CC.A.1.1.15 When a **User** identified on a **Site Responsibility Schedule**, or **NGET**, as the case may be, becomes aware that an alteration to the **Site Responsibility Schedule** is necessary urgently to reflect, for example, an emergency situation which has arisen outside its control, the **User** shall notify **NGET**, or **NGET** shall notify the **User**, as the case may be, immediately and will discuss:

- (a) what change is necessary to the **Site Responsibility Schedule**;
- (b) whether the **Site Responsibility Schedule** is to be modified temporarily or permanently;
- (c) the distribution of the revised **Site Responsibility Schedule**.

**NGET** will prepare a revised **Site Responsibility Schedule** as soon as possible, and in any event within seven days of it being informed of or knowing the necessary alteration. The **Site Responsibility Schedule** will be confirmed by **Users** and signed on behalf of **NGET** and **Users** (by the persons referred to in CC.A.1.1.9) as soon as possible after it has been prepared and sent to **Users** for confirmation.

#### Responsible Managers

CC.A.1.1.16 Each **User** shall, prior to the **Completion Date** under each **Bilateral Agreement** and/or **Construction Agreement**, supply to **NGET** a list of Managers who have been duly authorised to sign **Site Responsibility Schedules** on behalf of the **User** and **NGET** shall, prior to the **Completion Date** under each **Bilateral Agreement** and/or **Construction Agreement**, supply to that **User** the name of its **Responsible Manager** and for **Connection Sites** in Scotland or **Offshore**, the name of the **Relevant Transmission Licensee's Responsible Manager** and each shall supply to the other any changes to such list six weeks before the change takes effect where the change is anticipated, and as soon as possible after the change, where the change was not anticipated.

#### De-commissioning of Connection Sites

CC.A.1.1.17 Where a **Connection Site** is to be de-commissioned, whichever of **NGET** or the **User** who is initiating the de-commissioning must contact the other to arrange for the **Site Responsibility Schedule** to be amended at the relevant time.

# PROFORMA FOR SITE RESPONSIBILITY SCHEDULE

\_\_\_\_\_ AREA

COMPLEX: \_\_\_\_\_

SCHEDULE: \_\_\_\_\_

CONNECTION SITE: \_\_\_\_\_

| ITEM OF PLANT/<br>APPARATUS | PLANT APPARATUS<br>OWNER | SITE<br>MANAGER | SAFETY          |  | OPERATIONS                |  | PARTY<br>RESPONSIBLE<br>FOR<br>UNDERTAKING<br>STATUTORY<br>INSPECTIONS,<br>FAULT<br>INVESTIGATION<br>&<br>MAINTENANCE | REMARKS |
|-----------------------------|--------------------------|-----------------|-----------------|--|---------------------------|--|---|---------|
|                             |                          |                 | SAFETY<br>RULES | CONTROL OR<br>OTHER<br>RESPONSIBLE<br>PERSON<br>(SAFETY CO-<br>ORDINATOR | OPERATIONAL<br>PROCEDURES | CONTROL OR<br>OTHER<br>RESPONSIBLE<br>ENGINEER |   |         |
|                             |                          |                 |                 |  |                           |  |   |         |

PAGE: \_\_\_\_\_

ISSUE NO: \_\_\_\_\_

DATE: \_\_\_\_\_

# PROFORMA FOR SITE RESPONSIBILITY SCHEDULE

\_\_\_\_\_ AREA

COMPLEX: \_\_\_\_\_

SCHEDULE: \_\_\_\_\_

CONNECTION SITE: \_\_\_\_\_

| ITEM OF PLANT/<br>APPARATUS | PLANT APPARATUS<br>OWNER | SITE<br>MANAGER | SAFETY          |  | OPERATIONS                |  | PARTY<br>RESPONSIBLE<br>FOR<br>UNDERTAKING<br>STATUTORY<br>INSPECTIONS,<br>FAULT<br>INVESTIGATION<br>&<br>MAINTENANCE | REMARKS |
|-----------------------------|--------------------------|-----------------|-----------------|--|---------------------------|--|---|---------|
|                             |                          |                 | SAFETY<br>RULES | CONTROL OR<br>OTHER<br>RESPONSIBLE<br>PERSON<br>(SAFETY CO-<br>ORDINATOR | OPERATIONAL<br>PROCEDURES | CONTROL OR<br>OTHER<br>RESPONSIBLE<br>ENGINEER |   |         |
|                             |                          |                 |                 |  |                           |  |   |         |

**NOTES:**

SIGNED: \_\_\_\_\_ NAME: \_\_\_\_\_ COMPANY: \_\_\_\_\_ DATE: \_\_\_\_\_

SIGNED: \_\_\_\_\_ NAME: \_\_\_\_\_ COMPANY: \_\_\_\_\_ DATE: \_\_\_\_\_

SIGNED: \_\_\_\_\_ NAME: \_\_\_\_\_ COMPANY: \_\_\_\_\_ DATE: \_\_\_\_\_

SIGNED: \_\_\_\_\_ NAME: \_\_\_\_\_ COMPANY: \_\_\_\_\_ DATE: \_\_\_\_\_

PAGE: \_\_\_\_\_ ISSUE NO: \_\_\_\_\_ DATE: \_\_\_\_\_

**SP TRANSMISSION Ltd  
 SITE RESPONSIBILITY SCHEDULE  
 OWNERSHIP, MAINTENANCE AND OPERATIONS OF EQUIPMENT  
 IN JOINT USER SITUATIONS**

Network Area: \_\_\_\_\_

Sheet No. \_\_\_\_\_  
 Revision: \_\_\_\_\_  
 Date: \_\_\_\_\_

**SECTION 'A' BUILDING AND SITE**

|             |                                |                                     |
|-------------|--------------------------------|-------------------------------------|
| OWNER       | ACCESS REQUIRED:-              | SECTION 'B' CUSTOMER OR OTHER PARTY |
| LESSEE      | SPECIAL CONDITIONS:-           | NAME:-                              |
| MAINTENANCE | LOCATION OF SUPPLY TERMINALS:- | ADDRESS:-                           |
| SAFETY      |                                | TEL NO:-                            |
| SECURITY    |                                | SUB STATION:-                       |
|             |                                | LOCATION:-                          |

**SECTION 'C' PLANT**

| ITEM Nos. | EQUIPMENT | IDENTIFICATION | OWNER | SAFETY RULES APPLICABLE | OPERATION |         |           |          | MAINTENANCE    |                   | FAULT INVESTIGATION |                   | TESTING       |                | RELAY SETTINGS | REMARKS |
|-----------|-----------|----------------|-------|-------------------------|-----------|---------|-----------|----------|----------------|-------------------|---------------------|-------------------|---------------|----------------|----------------|---------|
|           |           |                |       |                         | Tripping  | Closing | Isolating | Earthing | Primary Equip. | Protection Equip. | Primary Equip.      | Protection Equip. | Tip and Alarm | Primary Equip. |                |         |
|           |           |                |       |                         |           |         |           |          |                |                   |                     |                   |               |                |                |         |

**SECTION 'D' CONFIGURATION AND CONTROL**

| ITEM Nos. | CONFIGURATION RESPONSIBILITY | TELEPHONE NUMBER | REMARKS |
|-----------|------------------------------|------------------|---------|
|           |                              |                  |         |
|           |                              |                  |         |

**SECTION 'E' ADDITIONAL INFORMATION**

|  |  |  |  |
|--|--|--|--|
|  |  |  |  |
|--|--|--|--|

- ABBREVIATIONS:**  
 D- SP AUTHORIZED PERSON - DISTRIBUTION SYSTEM  
 NGC- NATIONAL GRID COMPANY  
 SPD- SP DISTRIBUTION LTD  
 SPPS- POWERSYSTEMS  
 SPT - SP TRANSMISSION LTD  
 ST - SCOTTISH POWER TELECOMMUNICATIONS  
 T - SP AUTHORIZED PERSON - TRANSMISSION SYSTEM  
 U- USER

SIGNED \_\_\_\_\_ FOR \_\_\_\_\_ DATE \_\_\_\_\_

SIGNED \_\_\_\_\_ FOR \_\_\_\_\_ DATE \_\_\_\_\_

SIGNED \_\_\_\_\_ FOR \_\_\_\_\_ DATE \_\_\_\_\_



# APPENDIX 2 - OPERATION DIAGRAMS

## PART 1A - PROCEDURES RELATING TO OPERATION DIAGRAMS

|   |  |  |  |
|---|--|--|--|
| FIXED CAPACITOR                                   |  | SWITCH DISCONNECTOR                                |  |
| EARTH   |  | SWITCH DISCONNECTOR WITH INCORPORATED EARTH SWITCH |  |
| EARTHING RESISTOR                                 |  | DISCONNECTOR (CENTRE ROTATING POST)                |  |
| LIQUID EARTHING RESISTOR                          |  | DISCONNECTOR (SINGLE BREAK DOUBLE ROTATING)        |  |
| ARC SUPPRESSION COIL                              |  | DISCONNECTOR (SINGLE BREAK)                        |  |
| FIXED MAINTENANCE EARTHING DEVICE                 |  | DISCONNECTOR (NON-INTERLOCKED)                     |  |
| CARRIER COUPLING EQUIPMENT (WITHOUT VT)           |  | DISCONNECTOR (POWER OPERATED)                      |  |
| CARRIER COUPLING EQUIPMENT (WITH VT ON ONE PHASE) |  | DISCONNECTOR (NON-AUTOMATIC)                       |  |
| CARRIER COUPLING EQUIPMENT (WITH VT ON 3 PHASES)  |  | DISCONNECTOR (AUTOMATIC)                           |  |
| AC GENERATOR                                      |  | DISCONNECTOR (SEQUENTIAL OPERATION)                |  |
| SYNCHRONOUS COMPENSATOR                           |  | DISCONNECTOR (FAULT INTERFERING OPERATION)         |  |
| CIRCUIT BREAKER                                   |  | EARTH SWITCH                                       |  |
| CIRCUIT BREAKER WITH DELAYED AUTO RECLOSE         |  | FAULT THROWING SWITCH (PHASE TO PHASE)             |  |
| WITHDRAWABLE METALCLAD SWITCHGEAR                 |  | FAULT THROWING SWITCH (EARTH FAULT)                |  |
|   |  | SURGE ARRESTOR                                     |  |
|   |  | THYRISTOR  |  |

TRANSFORMERS  
(VECTORS TO INDICATE  
WINDING CONFIGURATION)

TWO WINDING



THREE WINDING

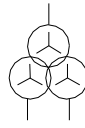

AUTO



AUTO WITH DELTA TERTIARY

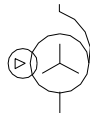

EARTHING OR AUX. TRANSFORMER

(-) INDICATE REMOTE SITE  
IF APPLICABLE

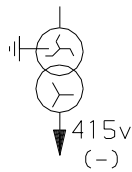

VOLTAGE TRANSFORMERS

SINGLE PHASE WOUND



THREE PHASE WOUND



SINGLE PHASE CAPACITOR



TWO SINGLE PHASE CAPACITOR

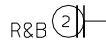

THREE PHASE CAPACITOR



\* CURRENT TRANSFORMER  
(WHERE SEPARATE PRIMARY  
APPARATUS)



\* COMBINED VT/CT UNIT  
FOR METERING

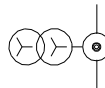

REACTOR



\* BUSBARS



\* OTHER PRIMARY CONNECTIONS



\* CABLE & CABLE SEALING END

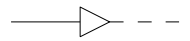

\* THROUGH WALL BUSHING

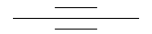

\* BYPASS FACILITY



\* CROSSING OF CONDUCTORS  
(LOWER CONDUCTOR  
TO BE BROKEN)

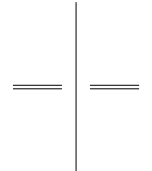

PREFERENTIAL ABBREVIATIONS

|                       |          |
|-----------------------|----------|
| AUXILIARY TRANSFORMER | Aux T    |
| EARTHING TRANSFORMER  | ET       |
| GAS TURBINE           | Gas T    |
| GENERATOR TRANSFORMER | Gen T    |
| GRID TRANSFORMER      | Gr T     |
| SERIES REACTOR        | Ser Reac |
| SHUNT REACTOR         | Sh Reac  |
| STATION TRANSFORMER   | Stn T    |
| SUPERGRID TRANSFORMER | SGT      |
| UNIT TRANSFORMER      | UT       |

\* NON-STANDARD SYMBOL



PORTABLE MAINTENANCE  
EARTH DEVICE



DISCONNECTOR  
(PANTOGRAPH TYPE)



QUADRATURE BOOSTER

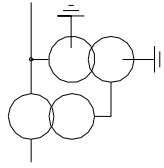

DISCONNECTOR  
(KNEE TYPE)



SHORTING/DISCHARGE SWITCH

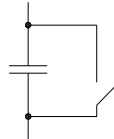

CAPACITOR  
(INCLUDING HARMONIC FILTER)



SINGLE PHASE TRANSFORMER (BR)  
NEUTRAL AND PHASE CONNECTIONS

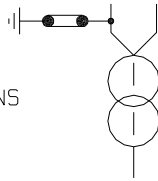

RESISTOR WITH INHERENT  
NON-LINEAR VARIABILITY,  
VOLTAGE DEPENDANT

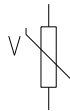

## PART 1B - PROCEDURES RELATING TO GAS ZONE DIAGRAMS

GAS INSULATED  
BUSBAR

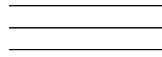

DOUBLE-BREAK  
DISCONNECTOR

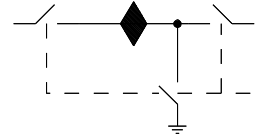

GAS BOUNDARY



EXTERNAL MOUNTED  
CURRENT TRANSFORMER  
(WHERE SEPARATE  
PRIMARY APPARATUS)

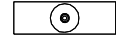

GAS/GAS BOUNDARY



STOP VALVE  
NORMALLY CLOSED



GAS/CABLE BOUNDARY



STOP VALVE  
NORMALLY OPEN



GAS/AIR BOUNDARY



GAS MONITOR



GAS/TRANSFORMER BOUNDARY



FILTER



MAINTENANCE VALVE

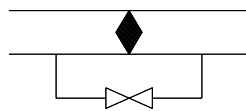

QUICK ACTING COUPLING



## **PART 2 - NON-EXHAUSTIVE LIST OF APPARATUS TO BE INCLUDED ON OPERATION DIAGRAMS**

### Basic Principles

- (1) Where practicable, all the **HV Apparatus** on any **Connection Site** shall be shown on one **Operation Diagram**. Provided the clarity of the diagram is not impaired, the layout shall represent as closely as possible the geographical arrangement on the **Connection Site**.
- (2) Where more than one **Operation Diagram** is unavoidable, duplication of identical information on more than one **Operation Diagram** must be avoided.
- (3) The **Operation Diagram** must show accurately the current status of the **Apparatus** e.g. whether commissioned or decommissioned. Where decommissioned, the associated switchbay will be labelled "spare bay".
- (4) Provision will be made on the **Operation Diagram** for signifying approvals, together with provision for details of revisions and dates.
- (5) **Operation Diagrams** will be prepared in A4 format or such other format as may be agreed with **NGET**.
- (6) The **Operation Diagram** should normally be drawn single line. However, where appropriate, detail which applies to individual phases shall be shown. For example, some **HV Apparatus** is numbered individually per phase.

### Apparatus To Be Shown On Operation Diagram

- (1) Busbars
- (2) Circuit Breakers
- (3) Disconnecter (Isolator) and Switch Disconnecters (Switching Isolators)
- (4) Disconnectors (Isolators) - Automatic Facilities
- (5) Bypass Facilities
- (6) Earthing Switches
- (7) Maintenance Earths
- (8) Overhead Line Entries
- (9) Overhead Line Traps
- (10) Cable and Cable Sealing Ends
- (11) Generating Unit
- (12) Generator Transformers
- (13) Generating Unit Transformers, Station Transformers, including the lower voltage circuit-breakers.
- (14) Synchronous Compensators
- (15) Static Variable Compensators
- (16) Capacitors (including Harmonic Filters)
- (17) Series or Shunt Reactors (Referred to as "Inductors" at nuclear power station sites)
- (18) Supergrid and Grid Transformers
- (19) Tertiary Windings
- (20) Earthing and Auxiliary Transformers

- (21) Three Phase VT's
- (22) Single Phase VT & Phase Identity
- (23) High Accuracy VT and Phase Identity
- (24) Surge Arrestors/Diverter
- (25) Neutral Earthing Arrangements on HV Plant
- (26) Fault Throwing Devices
- (27) Quadrature Boosters
- (28) Arc Suppression Coils
- (29) Single Phase Transformers (BR) Neutral and Phase Connections
- (30) Current Transformers (where separate plant items)
- (31) Wall Bushings
- (32) Combined VT/CT Units
- (33) Shorting and Discharge Switches
- (34) Thyristor
- (35) Resistor with Inherent Non-Linear Variability, Voltage Dependent
- (36) Gas Zone

## APPENDIX 3 - MINIMUM FREQUENCY RESPONSE REQUIREMENT PROFILE AND OPERATING RANGE FOR NEW POWER STATIONS AND DC CONVERTER STATIONS

### CC.A.3.1 Scope

The frequency response capability is defined in terms of **Primary Response**, **Secondary Response** and **High Frequency Response**. This appendix defines the minimum frequency response requirement profile for:

- (a) each **Onshore Generating Unit** and/or **CCGT Module** which has a **Completion Date** after 1 January 2001 in England and Wales and 1 April 2005 in Scotland and **Offshore Generating Unit** in a **Large Power Station**,
- (b) each **DC Converter** at a **DC Converter Station** which has a **Completion Date** on or after 1 April 2005 or each **Offshore DC Converter** which is part of a **Large Power Station**.
- (c) each **Onshore Power Park Module** in England and Wales with a **Completion Date** on or after 1 January 2006.
- (d) each **Onshore Power Park Module** in operation in Scotland after 1 January 2006 with a **Completion Date** after 1 April 2005 and in **Power Stations** with a **Registered Capacity** of 50MW or more.
- (e) each **Offshore Power Park Module** in a **Large Power Station** with a **Registered Capacity** of 50MW or more.

For the avoidance of doubt, this appendix does not apply to:

- (i) **Generating Units** and/or **CCGT Modules** which have a **Completion Date** before 1 January 2001 in England and Wales and before 1 April 2005 in Scotland,
- (ii) **DC Converters** at a **DC Converter Station** which have a **Completion Date** before 1 April 2005.
- (iii) **Power Park Modules** in England and Wales with a **Completion Date** before 1 January 2006.
- (iv) **Power Park Modules** in operation in Scotland before 1 January 2006.
- (v) **Power Park Modules** in Scotland with a **Completion Date** before 1 April 2005.
- (vi) **Power Park Modules** in **Power Stations** with a **Registered Capacity** less than 50MW.
- (vii) **Small Power Stations** or individually to **Power Park Units**; or.
- (viii) an **OTSDUW DC Converter** where the **Interface Point Capacity** is less than 50MW.

**OTSDUW Plant and Apparatus** should facilitate the delivery of frequency response services provided by **Offshore Generating Units** and **Offshore Power Park Modules** at the **Interface Point**.

The functional definition provides appropriate performance criteria relating to the provision of Frequency control by means of Frequency sensitive generation in addition to the other requirements identified in CC.6.3.7.

In this Appendix 3 to the **CC**, for a **CCGT Module** or a **Power Park Module** with more than one **Generating Unit**, the phrase **Minimum Generation** applies to the entire **CCGT Module** or **Power Park Module** operating with all **Generating Units Synchronised** to the **System**.

The minimum **Frequency** response requirement profile is shown diagrammatically in Figure CC.A.3.1. The capability profile specifies the minimum required levels of **Primary Response**, **Secondary Response** and **High Frequency Response** throughout the normal plant operating range. The definitions of these **Frequency** response capabilities are illustrated diagrammatically in Figures CC.A.3.2 & CC.A.3.3.

#### CC.A.3.2

##### Plant Operating Range

The upper limit of the operating range is the **Registered Capacity** of the **Generating Unit** or **CCGT Module** or **DC Converter** or **Power Park Module**.

The **Minimum Generation** level may be less than, but must not be more than, 65% of the **Registered Capacity**. Each **Generating Unit** and/or **CCGT Module** and/or **Power Park Module** and/or **DC Converter** must be capable of operating satisfactorily down to the **Designed Minimum Operating Level** as dictated by **System** operating conditions, although it will not be instructed to below its **Minimum Generation** level. If a **Generating Unit** or **CCGT Module** or **Power Park Module** or **DC Converter** is operating below **Minimum Generation** because of high **System Frequency**, it should recover adequately to its **Minimum Generation** level as the **System Frequency** returns to **Target Frequency** so that it can provide **Primary** and **Secondary Response** from **Minimum Generation** if the **System Frequency** continues to fall. For the avoidance of doubt, under normal operating conditions steady state operation below **Minimum Generation** is not expected. The **Designed Minimum Operating Level** must not be more than 55% of **Registered Capacity**.

In the event of a **Generating Unit** or **CCGT Module** or **Power Park Module** or **DC Converter** load rejecting down to no less than its **Designed Minimum Operating Level** it should not trip as a result of automatic action as detailed in BC3.7. If the load rejection is to a level less than the **Designed Minimum Operating Level** then it is accepted that the condition might be so severe as to cause it to be disconnected from the **System**.

#### CC.A.3.3

##### Minimum Frequency Response Requirement Profile

Figure CC.A.3.1 shows the minimum **Frequency** response requirement profile diagrammatically for a 0.5 Hz change in **Frequency**. The percentage response capabilities and loading levels are defined on the basis of the **Registered Capacity** of the **Generating Unit** or **CCGT Module** or **Power Park Module** or **DC Converter**. Each **Generating Unit** and/or **CCGT Module** and/or **Power Park Module** and/or **DC Converter** must be capable of operating in a manner to provide **Frequency** response at least to the solid boundaries shown in the figure. If the **Frequency** response capability falls within the solid boundaries, the **Generating Unit** or **CCGT Module** or **Power Park Module** or **DC Converter** is providing response below the minimum requirement which is not acceptable. Nothing in this appendix is intended to prevent a **Generating Unit** or **CCGT Module** or **Power Park Module** or **DC Converter** from being designed to deliver a **Frequency** response in excess of the identified minimum requirement.

The **Frequency** response delivered for **Frequency** deviations of less than 0.5 Hz should be no less than a figure which is directly proportional to the minimum **Frequency** response requirement for a **Frequency** deviation of 0.5 Hz. For example, if the **Frequency** deviation is 0.2 Hz, the corresponding minimum **Frequency** response requirement is 40% of the level shown in Figure CC.A.3.1. The **Frequency** response delivered for **Frequency** deviations of more than 0.5 Hz should be no less than the response delivered for a **Frequency** deviation of 0.5 Hz.

Each **Generating Unit** and/or **CCGT Module** and/or **Power Park Module** and/or **DC Converter** must be capable of providing some response, in keeping with its specific operational characteristics, when operating between 95% to 100% of **Registered Capacity** as illustrated by the dotted lines in Figure CC.A.3.1.

At the **Minimum Generation** level, each **Generating Unit** and/or **CCGT Module** and/or **Power Park Module** and/or **DC Converter** is required to provide high and low frequency response depending on the **System Frequency** conditions. Where the **Frequency** is high, the **Active Power** output is therefore expected to fall below the **Minimum Generation** level.

The **Designed Minimum Operating Level** is the output at which a **Generating Unit** and/or **CCGT Module** and/or **Power Park Module** and/or **DC Converter** has no **High Frequency Response** capability. It may be less than, but must not be more than, 55% of the **Registered Capacity**. This implies that a **Generating Unit** or **CCGT Module** or **Power Park Module** or **DC Converter** is not obliged to reduce its output to below this level unless the **Frequency** is at or above 50.5 Hz (cf BC3.7).

#### CC.A.3.4

##### Testing Of Frequency Response Capability

The response capabilities shown diagrammatically in Figure CC.A.3.1 are measured by taking the responses as obtained from some of the dynamic response tests specified by **NGET** and carried out by **Generators** and **DC Converter Station** owners for compliance purposes and to validate the content of **Ancillary Services Agreements** using an injection of a **Frequency** change to the plant control system (i.e. governor and load controller). The injected signal is a linear ramp from zero to 0.5 Hz **Frequency** change over a ten second period, and is sustained at 0.5 Hz **Frequency** change thereafter, as illustrated diagrammatically in figures CC.A.3.2 and CC.A.3.3. In the case of an **Embedded Medium Power Station** not subject to a **Bilateral Agreement** or **Embedded DC Converter Station** not subject to a **Bilateral Agreement**, **NGET** may require the **Network Operator** within whose **System** the **Embedded Medium Power Station** or **Embedded DC Converter Station** is situated, to ensure that the **Embedded Person** performs the dynamic response tests reasonably required by **NGET** in order to demonstrate compliance within the relevant requirements in the **CC**.

The **Primary Response** capability (P) of a **Generating Unit** or a **CCGT Module** or **Power Park Module** or **DC Converter** is the minimum increase in **Active Power** output between 10 and 30 seconds after the start of the ramp injection as illustrated diagrammatically in Figure CC.A.3.2. This increase in **Active Power** output should be released increasingly with time over the period 0 to 10 seconds from the time of the start of the **Frequency** fall as illustrated by the response from Figure CC.A.3.2.

The **Secondary Response** capability (S) of a **Generating Unit** or a **CCGT Module** or **Power Park Module** or **DC Converter** is the minimum increase in **Active Power** output between 30 seconds and 30 minutes after the start of the ramp injection as illustrated diagrammatically in Figure CC.A.3.2.

The **High Frequency Response** capability (H) of a **Generating Unit** or a **CCGT Module** or **Power Park Module** or **DC Converter** is the decrease in **Active Power** output provided 10 seconds after the start of the ramp injection and sustained thereafter as illustrated diagrammatically in Figure CC.A.3.3. This reduction in **Active Power** output should be released increasingly with time over the period 0 to 10 seconds from the time of the start of the **Frequency** rise as illustrated by the response in Figure CC.A.3.2.

#### CC.A.3.5

##### Repeatability Of Response

When a **Generating Unit** or **CCGT Module** or **Power Park Module** or **DC Converter** has responded to a significant **Frequency** disturbance, its response capability must be fully restored as soon as technically possible. Full response capability should be restored no later than 20 minutes after the initial change of **System Frequency** arising from the **Frequency** disturbance.



Figure CC.A.3.1 - Minimum Frequency Response Requirement Profile for a 0.5 Hz frequency change from Target Frequency

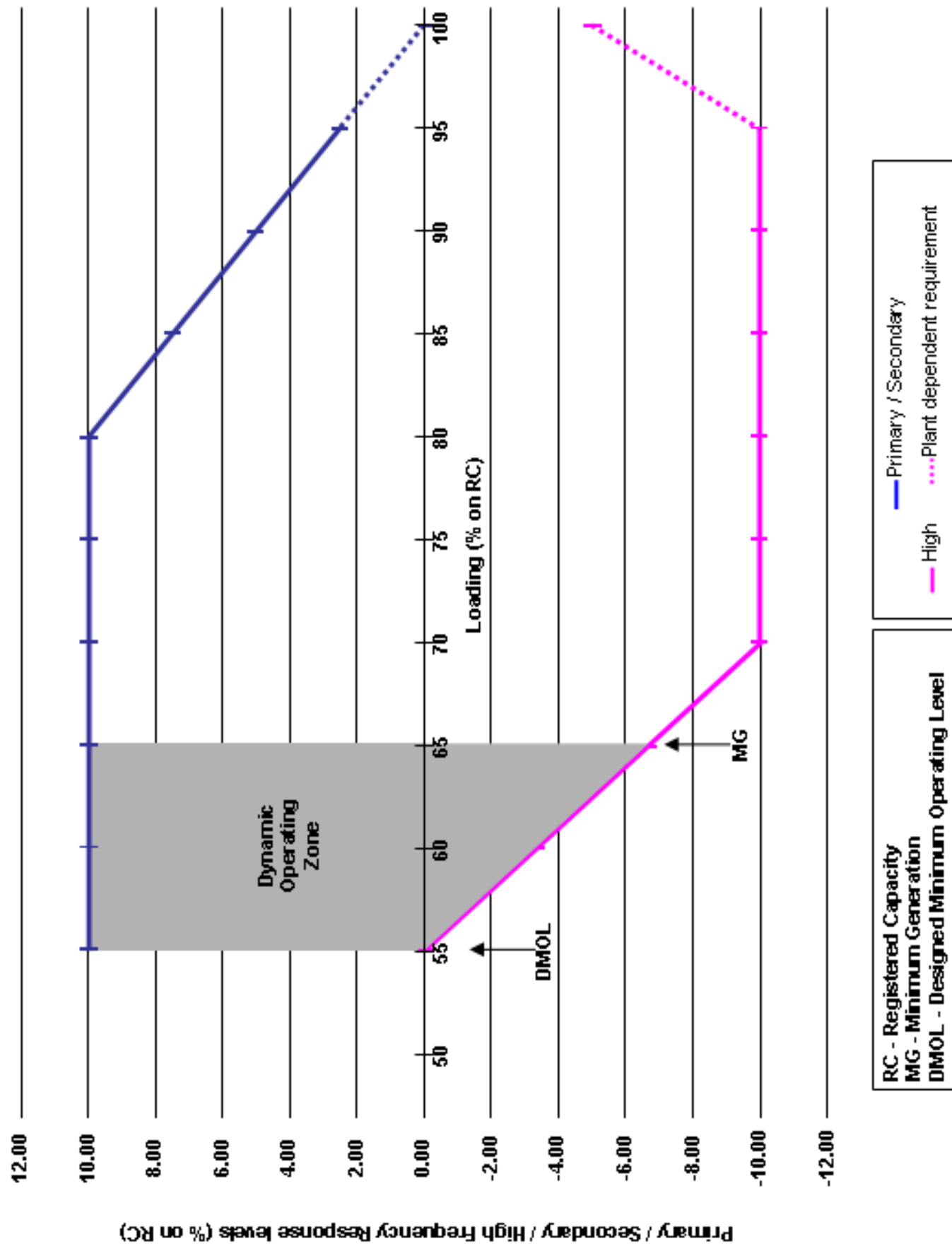

RC - Registered Capacity  
 MG - Minimum Generation  
 DMOL - Designed Minimum Operating Level

Primary / Secondary  
 High  
 Plant dependent requirement

Figure CC.A.3.2 - Interpretation of Primary and Secondary Response Values

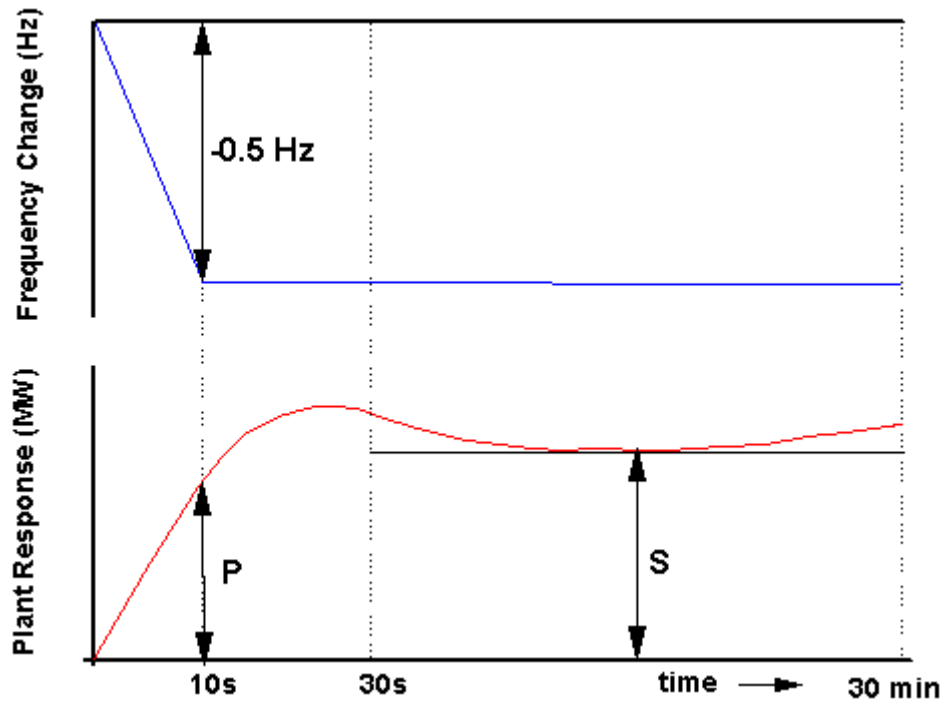
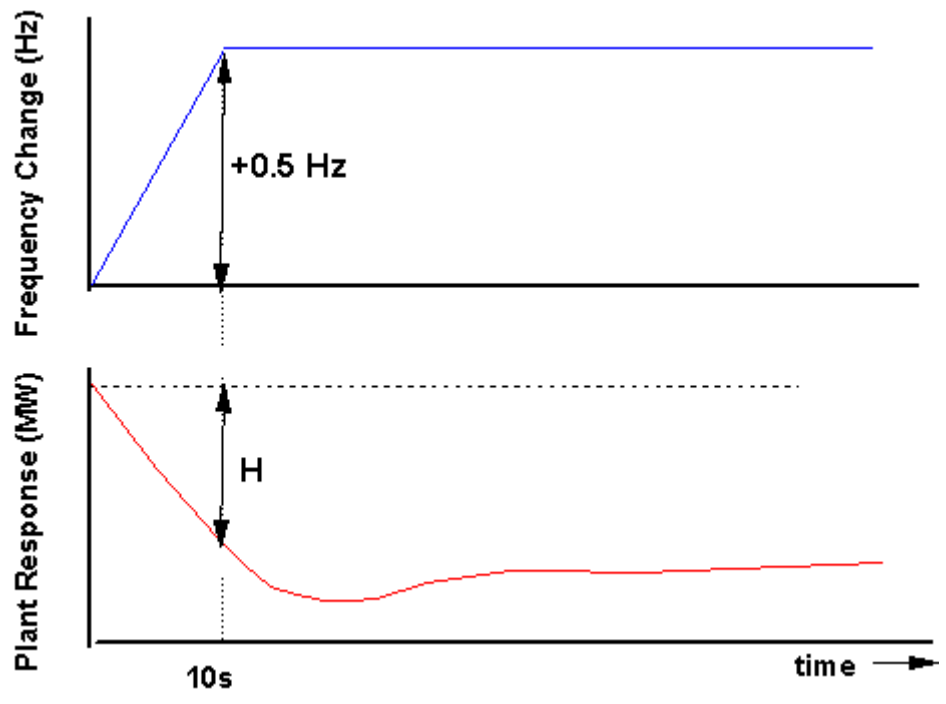

Figure CC.A.3.3 - Interpretation of High Frequency Response Values



## APPENDIX 4 - FAULT RIDE THROUGH REQUIREMENTS

### APPENDIX 4A - FAULT RIDE THROUGH REQUIREMENTS FOR ONSHORE GENERATING UNITS, ONSHORE POWER PARK MODULES, ONSHORE DC CONVERTERS OTSDUW PLANT AND APPARATUS AT THE INTERFACE POINT, OFFSHORE POWER PARK MODULES IN A LARGE POWER STATION AND OFFSHORE DC CONVERTERS IN A LARGE POWER STATION WHICH SELECT TO MEET THE FAULT RIDE THROUGH REQUIREMENTS AT THE INTERFACE POINT

#### CC.A.4A.1 Scope

The fault ride through requirement is defined in CC.6.3.15.1 (a), (b) and CC.6.3.15.3. This Appendix provides illustrations by way of examples only of CC.6.3.15.1 (a) (i) and further background and illustrations to CC.6.3.15.1 (b) (i) and is not intended to show all possible permutations.

#### CC.A.4A.2 Short Circuit Faults At Supergrid Voltage On The Onshore Transmission System Up To 140ms In Duration

For short circuit faults at **Supergrid Voltage** on the **Onshore Transmission System** (which could be at an **Interface Point**) up to 140ms in duration, the fault ride through requirement is defined in CC.6.3.15.1 (a) (i). Figures CC.A.4A.1 (a) and (b) illustrate two typical examples of voltage recovery for short-circuit faults cleared within 140ms by two circuit breakers (a) and three circuit breakers (b) respectively.

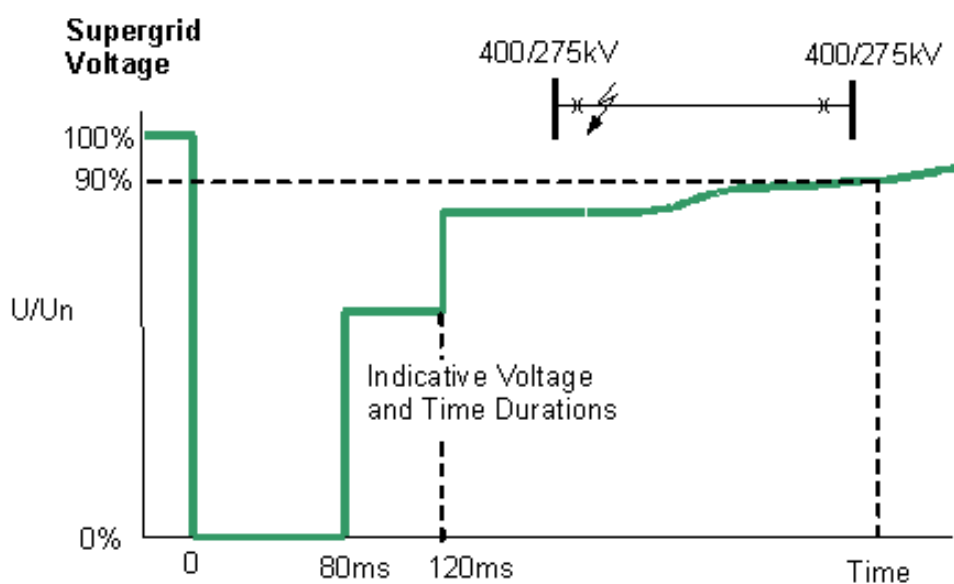

Typical fault cleared in less than 140ms: 2 ended circuit

Figure CC.A.4A.1 (a)

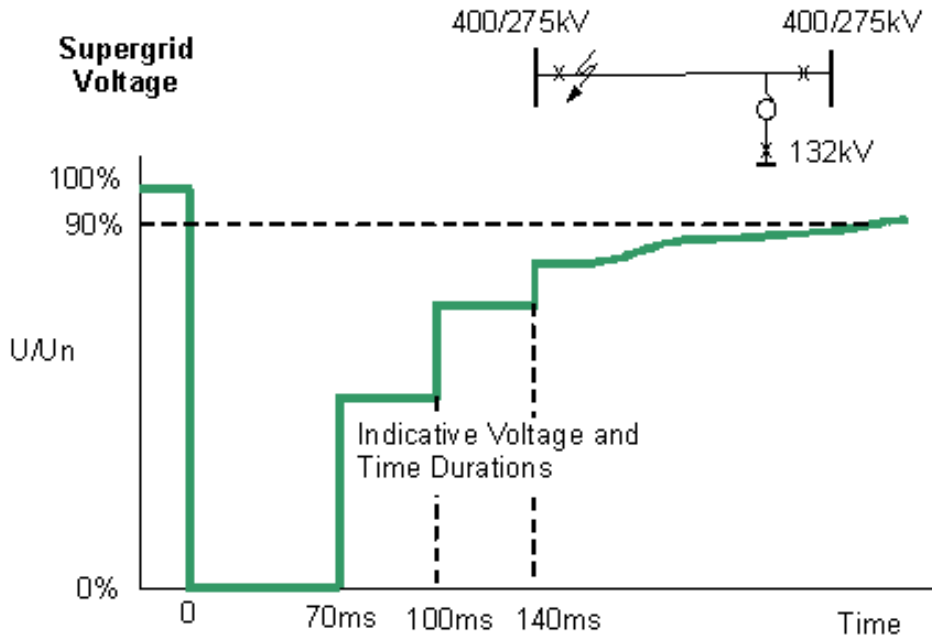

Typical fault cleared in 140ms:- 3 ended circuit

Figure CC.A.4A.1 (b)

CC.A.4A.3 Supergrid Voltage Dips On The Onshore Transmission System Greater Than 140ms In Duration

For balanced **Supergrid Voltage** dips on the **Onshore Transmission System** (which could be at an **Interface Point**) having durations greater than 140ms and up to 3 minutes the fault ride through requirement is defined in CC.6.3.15.1 (b) (i) and Figure 5 which is reproduced in this Appendix as Figure CC.A.4A.2 and termed the voltage–duration profile.

This profile is not a voltage-time response curve that would be obtained by plotting the transient voltage response at a point on the **Onshore Transmission System** (or **User System** if located **Onshore**) to a disturbance. Rather, each point on the profile (i.e. the heavy black line) represents a voltage level and an associated time duration which connected **Generating Units, Power Park Modules** or **OTSDUW Plant and Apparatus** must withstand or ride through.

Figures CC.A.4A.3 (a), (b) and (c) illustrate the meaning of the voltage-duration profile for voltage dips having durations greater than 140ms.

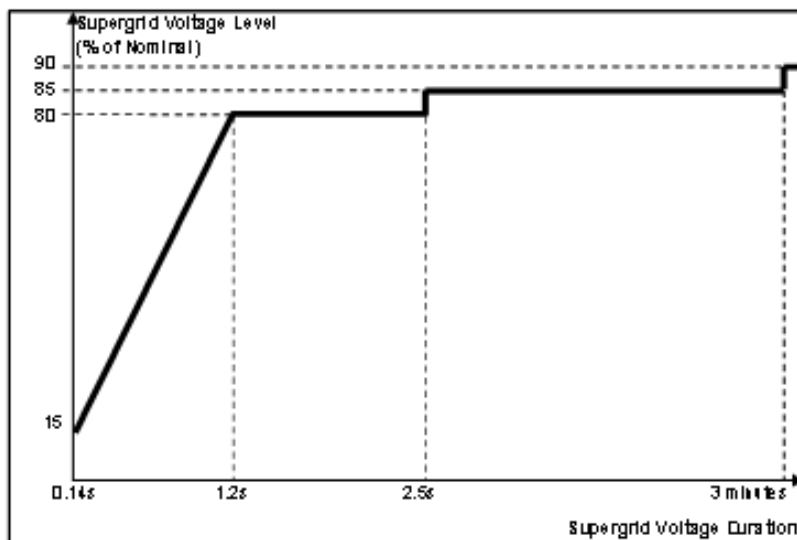
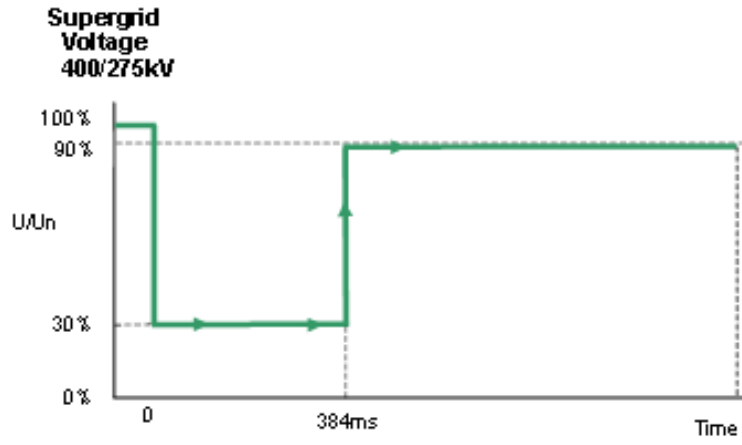
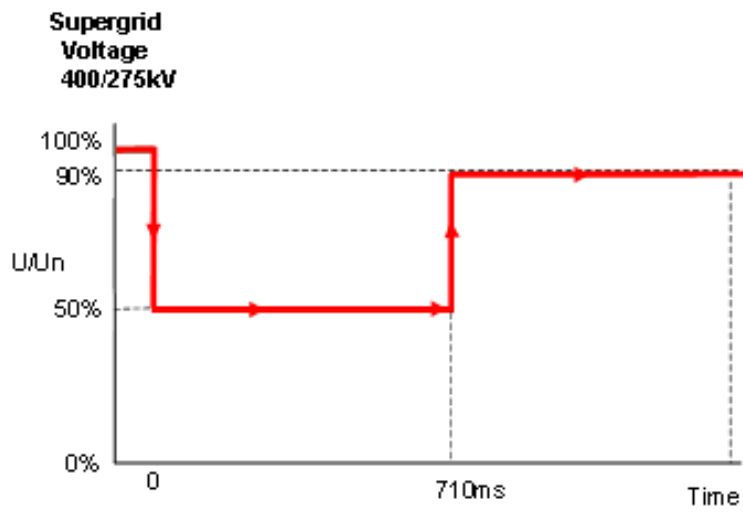

Figure CC.A.4A.2



30% retained voltage, 384ms duration

Figure CC.A.4A.3 (a)



50% retained voltage, 710ms duration

Figure CC.A.4A.3 (b)

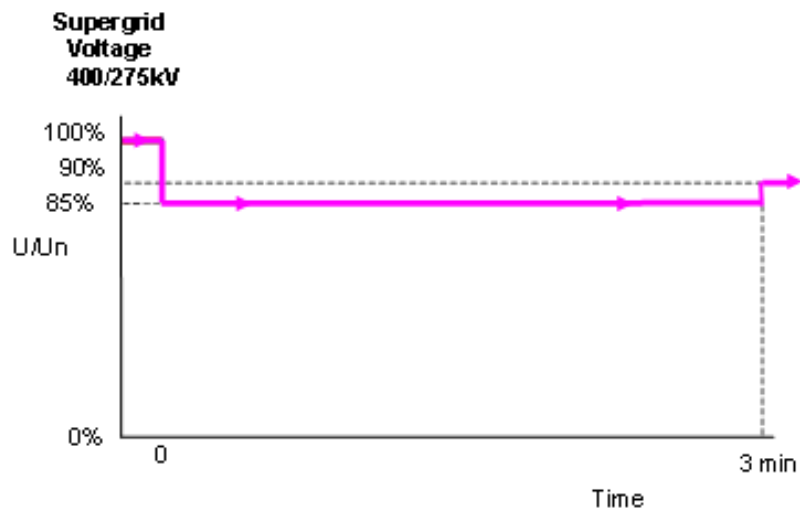

85% retained voltage, 3 minutes duration

Figure CC.A.4A.3 (c)

**APPENDIX 4B - FAULT RIDE THROUGH REQUIREMENTS FOR  
OFFSHORE GENERATING UNITS IN A LARGE POWER STATION,  
OFFSHORE POWER PARK MODULES IN A LARGE POWER STATION  
AND OFFSHORE DC CONVERTERS IN A LARGE POWER STATION  
WHICH SELECT TO MEET THE FAULT RIDE THROUGH REQUIREMENTS  
AT THE LV SIDE OF THE OFFSHORE PLATFORM AS SPECIFIED IN  
CC.6.3.15.2**

CC.A.4B.1 Scope

The fault ride through requirement is defined in CC.6.3.15.2 (a), (b) and CC.6.3.15.3. This Appendix provides illustrations by way of examples only of CC.6.3.15.2 (a) (i) and further background and illustrations to CC.6.3.15.2 (b) (i) and is not intended to show all possible permutations.

CC.A.4B.2 Voltage Dips On The LV Side Of The Offshore Platform Up To 140ms In Duration

For voltage dips on the **LV Side of the Offshore Platform** which last up to 140ms in duration, the fault ride through requirement is defined in CC.6.3.15.2 (a) (i). This includes Figure 6 which is reproduced here in Figure CC.A.4B.1. The purpose of this requirement is to translate the conditions caused by a balanced or unbalanced fault which occurs on the **Onshore Transmission System** (which may include the **Interface Point**) at the **LV Side of the Offshore Platform**.

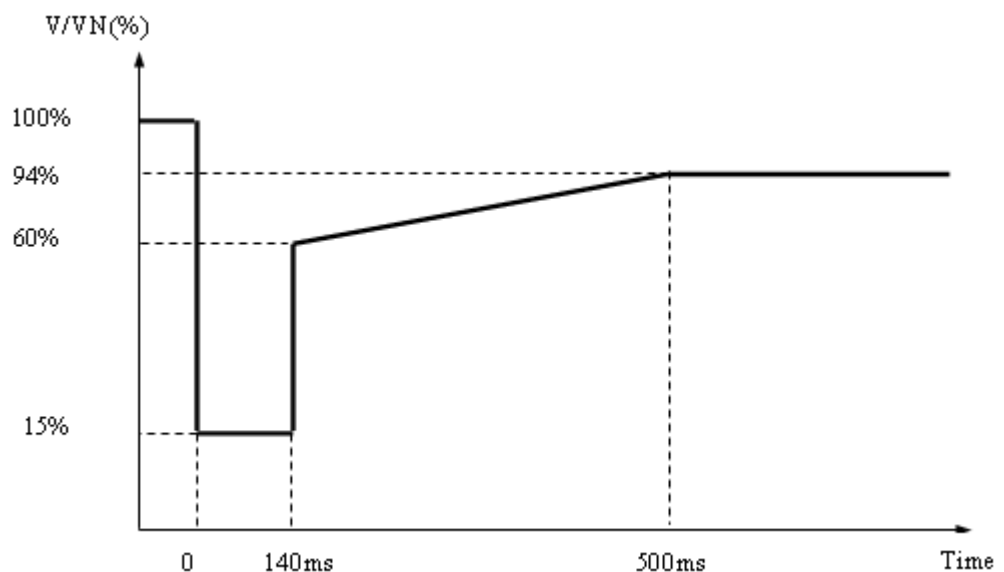

$V/V_N$  is the ratio of the voltage at the **LV side of the Offshore Platform** to the nominal voltage of the LV side of the **Offshore Platform**.

Figure CC.A.4B.1

Figures CC.A.4B.2 (a) and CC.A.4B.2 (b) illustrate two typical examples of the voltage recovery seen at the **LV Side of the Offshore Platform** for a short circuit fault cleared within 140ms by (a) two circuit breakers and (b) three circuit breakers on the **Onshore Transmission System**.

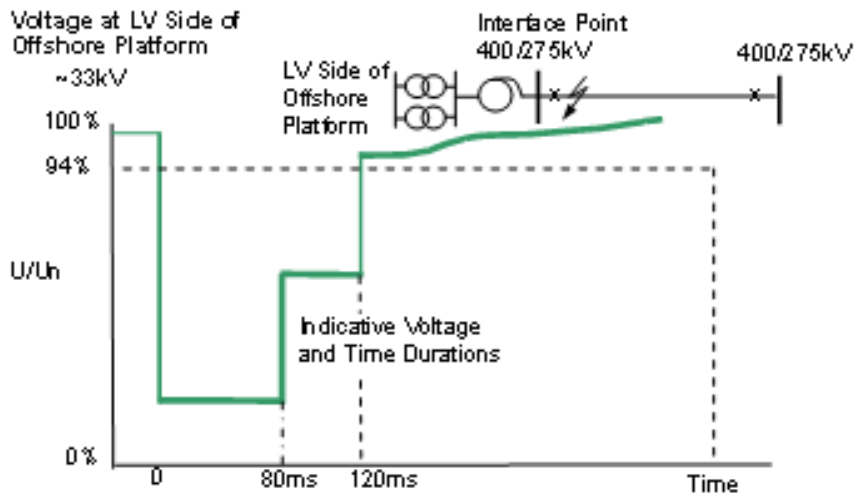

Typical fault cleared in less than 140ms: 2 ended circuit

Figure CC.A.4B.2 (a)

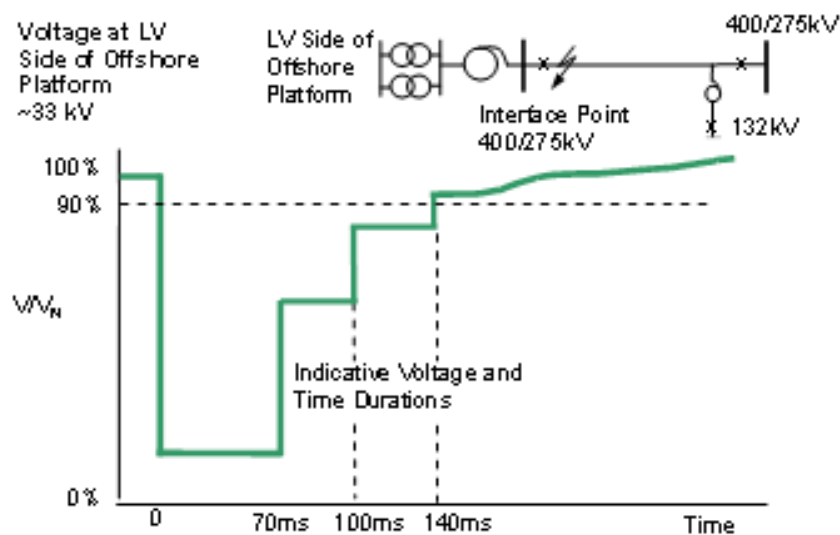

Typical fault cleared in 140ms:- 3 ended circuit

Figure CC.A.4B.2 (b)

### CCA.4B.3 Voltage Dips Which Occur On The LV Side Of The Offshore Platform Greater Than 140ms In Duration

In addition to CCA.4B.2 the fault ride through requirements applicable for **Offshore Generating Units**, and **Offshore Power Park Modules** during balanced voltage dips which occur at the **LV Side of the Offshore Platform** and have durations greater than 140ms and up to 3 minutes are defined in CC.6.3.15.2 (b) (i) and Figure 7 which is reproduced in this Appendix as Figure CC.A.4B.3 and termed the voltage–duration profile.

This profile is not a voltage-time response curve that would be obtained by plotting the transient voltage response at the **LV Side of the Offshore Platform** to a disturbance. Rather, each point on the profile (i.e. the heavy black line) represents a voltage level and an associated time duration which connected **Offshore Generating Units**, or **Offshore Power Park Modules** must withstand or ride through.

Figures CC.A.4B.3 (a), (b) and (c) illustrate the meaning of the voltage-duration profile for voltage dips having durations greater than 140ms.

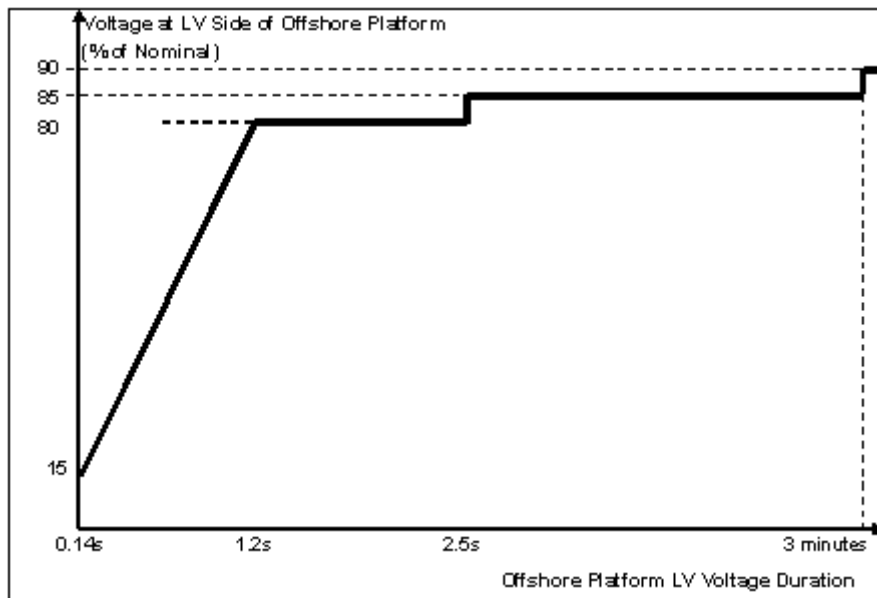
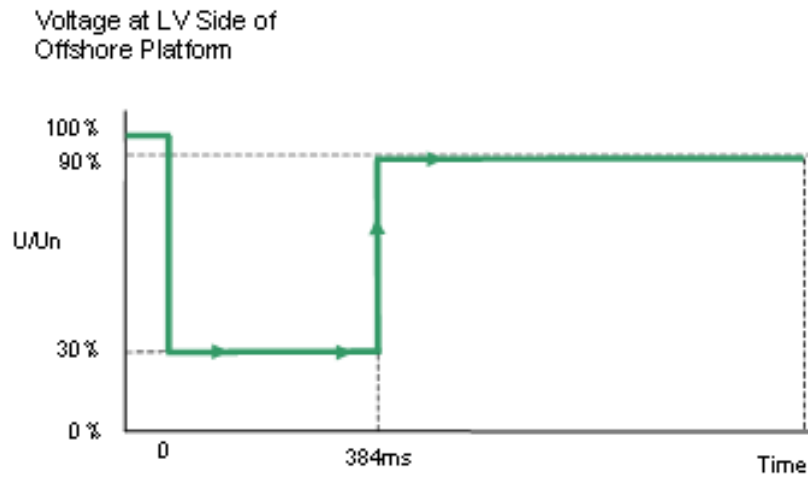

Figure CC.A.4B.3



30% retained voltage, 384ms duration

Figure CC.A.4B.3 (a)



**Voltage at LV Side of Offshore Platform**

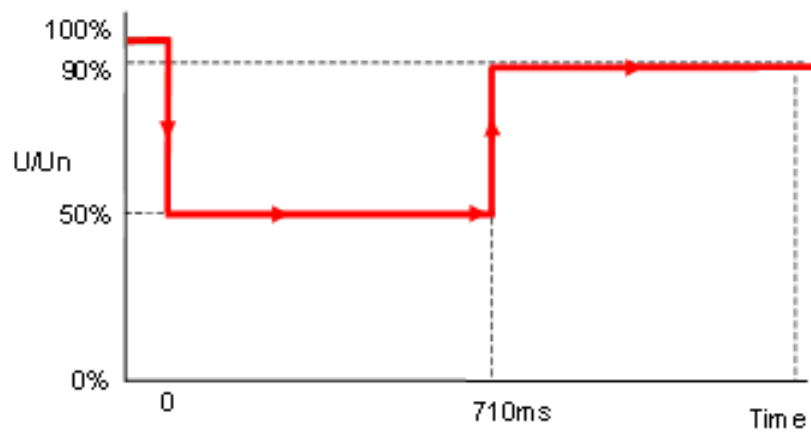

50% retained voltage, 710ms duration

Figure CC.A.4B.3(b)

**Voltage at LV Side of Offshore Platform**

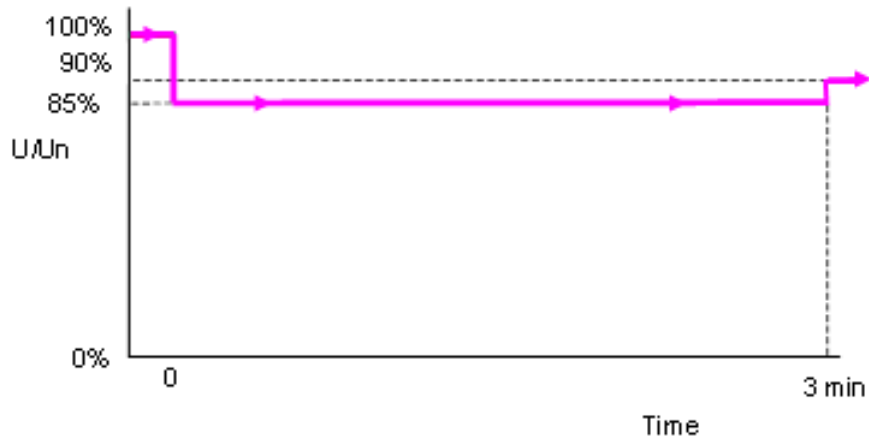

85% retained voltage, 3 minutes duration

Figure CC.A.4B.3(c)

## APPENDIX 5 - TECHNICAL REQUIREMENTS

### LOW FREQUENCY RELAYS FOR THE AUTOMATIC DISCONNECTION OF SUPPLIES AT LOW FREQUENCY

#### CC.A.5.1 Low Frequency Relays

CC.A.5.1.1 The **Low Frequency Relays** to be used shall have a setting range of 47.0 to 50Hz and be suitable for operation from a nominal AC input of 63.5, 110 or 240V. The following general parameters specify the requirements of approved **Low Frequency Relays** for automatic installations installed and commissioned after 1<sup>st</sup> April 2007 and provide an indication, without prejudice to the provisions that may be included in a **Bilateral Agreement**, for those installed and commissioned before 1<sup>st</sup> April 2007:

- (a) **Frequency** settings: 47-50Hz in steps of 0.05Hz or better, preferably 0.01Hz;
- (b) Operating time: Relay operating time shall not be more than 150 ms;
- (c) Voltage lock-out: Selectable within a range of 55 to 90% of nominal voltage;
- (d) Facility stages: One or two stages of **Frequency** operation;
- (e) Output contacts: Two output contacts per stage to be capable of repetitively making and breaking for 1000 operations;
- (f) Accuracy: 0.01 Hz maximum error under reference environmental and system voltage conditions.  
0.05 Hz maximum error at 8% of total harmonic distortion **Electromagnetic Compatibility Level**.

#### CC.A.5.2 Low Frequency Relay Voltage Supplies

CC.A.5.2.1 It is essential that the voltage supply to the **Low Frequency Relays** shall be derived from the primary **System** at the supply point concerned so that the **Frequency** of the **Low Frequency Relays** input voltage is the same as that of the primary **System**. This requires either:

- (a) the use of a secure supply obtained from voltage transformers directly associated with the grid transformer(s) concerned, the supply being obtained where necessary via a suitable automatic voltage selection scheme; or
- (b) the use of the substation 240V phase-to-neutral selected auxiliary supply, provided that this supply is always derived at the supply point concerned and is never derived from a standby supply **Generating Unit** or from another part of the **User System**.

#### CC.A.5.3 Scheme Requirements

CC.A.5.3.1 The tripping facility should be engineered in accordance with the following reliability considerations:

- (a) Dependability

Failure to trip at any one particular **Demand** shedding point would not harm the overall operation of the scheme. However, many failures would have the effect of reducing the amount of **Demand** under low **Frequency** control. An overall reasonable minimum requirement for the dependability of the **Demand** shedding scheme is 96%, i.e. the average probability of failure of each **Demand** shedding point should be less than 4%. Thus the **Demand** under low **Frequency** control will not be reduced by more than 4% due to relay failure.

(b) Outages

Low **Frequency Demand** shedding schemes will be engineered such that the amount of **Demand** under control is as specified in Table CC.A.5.5.1a and is not reduced unacceptably during equipment outage or maintenance conditions.

CC.A.5.3.2 The total operating time of the scheme, including circuit breakers operating time, shall where reasonably practicable, be less than 200 ms. For the avoidance of doubt, the replacement of plant installed prior to October 2009 will not be required in order to achieve lower total scheme operating times.

CC.A.5.4 Low Frequency Relay Testing

CC.A.5.4.1 **Low Frequency Relays** installed and commissioned after 1<sup>st</sup> January 2007 shall be type tested in accordance with and comply with the functional test requirements for **Frequency Protection** contained in Energy Networks Association Technical Specification 48-6-5 Issue 1 dated 2005 “**ENA Protection Assessment Functional Test Requirements – Voltage and Frequency Protection**”.

For the avoidance of doubt, **Low Frequency Relays** installed and commissioned before 1<sup>st</sup> January 2007 shall comply with the version of CC.A.5.1.1 applicable at the time such **Low Frequency Relays** were commissioned.

CC.A.5.5 Scheme Settings

CC.A.5.5.1 Table CC.A.5.5.1a shows, for each **Transmission Area**, the percentage of **Demand** (based on **Annual ACS Conditions**) at the time of forecast **National Electricity Transmission System** peak **Demand** that each **Network Operator** whose **System** is connected to the **Onshore Transmission System** within such **Transmission Area** shall disconnect by **Low Frequency Relays** at a range of frequencies. Where a **Network Operator’s System** is connected to the **National Electricity Transmission System** in more than one **Transmission Area**, the settings for the **Transmission Area** in which the majority of the **Demand** is connected shall apply.

| Frequency Hz | % <b>Demand</b> disconnection for each Network Operator in Transmission Area |     |       |
|--------------|--|-----|-------|
|              | <b>NGET</b>  | SPT | SHETL |
| 48.8         | 5  |     |       |
| 48.75        | 5  |     |       |
| 48.7         | 10   |     |       |
| 48.6         | 7.5  |     | 10    |
| 48.5         | 7.5  | 10  |       |
| 48.4         | 7.5  | 10  | 10    |
| 48.2         | 7.5  | 10  | 10    |

|                       |    |    |    |
|-----------------------|----|----|----|
| 48.0                  | 5  | 10 | 10 |
| 47.8                  | 5  |    |    |
| <b>Total % Demand</b> | 60 | 40 | 40 |

Table CC.A.5.5.1a

Note – the percentages in table CC.A.5.5.1a are cumulative such that, for example, should the frequency fall to 48.6 Hz in the **NGET Transmission Area**, 27.5% of the total **Demand** connected to the **National Electricity Transmission System** in the **NGET Transmission Area** shall be disconnected by the action of **Low Frequency Relays**.

The percentage **Demand** at each stage shall be allocated as far as reasonably practicable. The cumulative total percentage **Demand** is a minimum.

## APPENDIX 6 - PERFORMANCE REQUIREMENTS FOR CONTINUOUSLY ACTING AUTOMATIC EXCITATION CONTROL SYSTEMS FOR ONSHORE SYNCHRONOUS GENERATING UNITS

- CC.A.6.1 Scope
- CC.A.6.1.1 This Appendix sets out the performance requirements of continuously acting automatic excitation control systems for **Onshore Synchronous Generating Units** that must be complied with by the **User**. This Appendix does not limit any site specific requirements that may be included in a **Bilateral Agreement** where in **NGET's** reasonable opinion these facilities are necessary for system reasons.
- CC.A.6.1.2 Where the requirements may vary the likely range of variation is given in this Appendix. It may be necessary to specify values outside this range where **NGET** identifies a system need, and notwithstanding anything to the contrary **NGET** may specify in the **Bilateral Agreement** values outside of the ranges provided in this Appendix 6. The most common variations are in the on-load excitation ceiling voltage requirements and the response time required of the **Exciter**. Actual values will be included in the **Bilateral Agreement**.
- CC.A.6.1.3 Should a **Generator** anticipate making a change to the excitation control system it shall notify **NGET** under the **Planning Code** (PC.A.1.2(b) and (c)) as soon as the **Generator** anticipates making the change. The change may require a revision to the **Bilateral Agreement**.
- CC.A.6.2 Requirements
- CC.A.6.2.1 The **Excitation System** of an **Onshore Synchronous Generating Unit** shall include an excitation source (**Exciter**), a **Power System Stabiliser** and a continuously acting **Automatic Voltage Regulator (AVR)** and shall meet the following functional specification.
- CC.A.6.2.2 In respect of **Onshore Synchronous Generating Units** with a **Completion Date** on or after 1 January 2009, and **Onshore Synchronous Generating Units** with a **Completion Date** before 1 January 2009 subject to a **Modification** to the excitation control facilities where the **Bilateral Agreement** does not specify otherwise, the continuously acting automatic excitation control system shall include a **Power System Stabiliser (PSS)** as a means of supplementary control. The functional specification of the **Power System Stabiliser** is included in CC.A.6.2.5.
- CC.A.6.2.3 Steady State Voltage Control
- CC.A.6.2.3.1 An accurate steady state control of the **Onshore Generating Unit** pre-set terminal voltage is required. As a measure of the accuracy of the steady-state voltage control, the **Automatic Voltage Regulator** shall have static zero frequency gain, sufficient to limit the change in terminal voltage to a drop not exceeding 0.5% of rated terminal voltage, when the **Onshore Generating Unit** output is gradually changed from zero to rated MVA output at rated voltage, **Active Power** and **Frequency**.
- CC.A.6.2.4 Transient Voltage Control
- CC.A.6.2.4.1 For a step change from 90% to 100% of the nominal **Onshore Generating Unit** terminal voltage, with the **Onshore Generating Unit** on open circuit, the **Excitation System** response shall have a damped oscillatory characteristic. For this characteristic, the time for the **Onshore Generating Unit** terminal voltage to first reach 100% shall be less than 0.6 seconds. Also, the time to settle within 5% of the voltage change shall be less than 3 seconds.

CC.A.6.2.4.2 To ensure that adequate synchronising power is maintained, when the **Onshore Generating Unit** is subjected to a large voltage disturbance, the **Exciter** whose output is varied by the **Automatic Voltage Regulator** shall be capable of providing its achievable upper and lower limit ceiling voltages to the **Onshore Generating Unit** field in a time not exceeding that specified in the **Bilateral Agreement**. This will normally be not less than 50 ms and not greater than 300 ms. The achievable upper and lower limit ceiling voltages may be dependent on the voltage disturbance.

CC.A.6.2.4.3 The **Exciter** shall be capable of attaining an **Excitation System On Load Positive Ceiling Voltage** of not less than a value specified in the **Bilateral Agreement** that will be:

not less than 2 per unit (pu)

normally not greater than 3 pu

exceptionally up to 4 pu

of **Rated Field Voltage** when responding to a sudden drop in voltage of 10 percent or more at the **Onshore Generating Unit** terminals. **NGET** may specify a value outside the above limits where **NGET** identifies a system need.

CC.A.6.2.4.4 If a static type **Exciter** is employed:

(i) the field voltage should be capable of attaining a negative ceiling level specified in the **Bilateral Agreement** after the removal of the step disturbance of CC.A.6.2.4.3. The specified value will be 80% of the value specified in CC.A.6.2.4.3. **NGET** may specify a value outside the above limits where **NGET** identifies a system need.

(ii) the **Exciter** must be capable of maintaining free firing when the **Onshore Generating Unit** terminal voltage is depressed to a level which may be between 20% to 30% of rated terminal voltage

(iii) the **Exciter** shall be capable of attaining a positive ceiling voltage not less than 80% of the **Excitation System On Load Positive Ceiling Voltage** upon recovery of the **Onshore Generating Unit** terminal voltage to 80% of rated terminal voltage following fault clearance. **NGET** may specify a value outside the above limits where **NGET** identifies a system need.

(iv) The requirement to provide a separate power source for the **Exciter** will be specified in the **Bilateral Agreement** if **NGET** identifies a **Transmission System** need.

CC.A.6.2.5 Power Oscillations Damping Control

CC.A.6.2.5.1 To allow the **Onshore Generating Unit** to maintain second and subsequent swing stability and also to ensure an adequate level of low frequency electrical damping power, the **Automatic Voltage Regulator** shall include a **Power System Stabiliser** as a means of supplementary control.

CC.A.6.2.5.2 Whatever supplementary control signal is employed, it shall be of the type which operates into the **Automatic Voltage Regulator** to cause the field voltage to act in a manner which results in the damping power being improved while maintaining adequate synchronising power.

- CC.A.6.2.5.3 The arrangements for the supplementary control signal shall ensure that the **Power System Stabiliser** output signal relates only to changes in the supplementary control signal and not the steady state level of the signal. For example, if generator electrical power output is chosen as a supplementary control signal then the **Power System Stabiliser** output should relate only to changes in generator electrical power output and not the steady state level of power output. Additionally the **Power System Stabiliser** should not react to mechanical power changes in isolation for example during rapid changes in steady state load or when providing frequency response.
- CC.A.6.2.5.4 The output signal from the **Power System Stabiliser** shall be limited to not more than  $\pm 10\%$  of the **Onshore Generating Unit** terminal voltage signal at the **Automatic Voltage Regulator** input. The gain of the **Power System Stabiliser** shall be such that an increase in the gain by a factor of 3 shall not cause instability.
- CC.A.6.2.5.5 The **Power System Stabiliser** shall include elements that limit the bandwidth of the output signal. The bandwidth limiting must ensure that the highest frequency of response cannot excite torsional oscillations on other plant connected to the network. A bandwidth of 0-5Hz would be judged to be acceptable for this application.
- CC.A.6.2.5.6 The **Generator** will agree **Power System Stabiliser** settings with **NGET** prior to the on-load commissioning detailed in BC2.11.2(d). To allow assessment of the performance before on-load commissioning the **Generator** will provide to **NGET** a report covering the areas specified in CP.A.3.2.1.
- CC.A.6.2.5.7 The **Power System Stabiliser** must be active within the **Excitation System** at all times when **Synchronised** including when the **Under Excitation Limiter** or **Over Excitation Limiter** are active. When operating at low load when **Synchronising** or **De-Synchronising** an **Onshore Generating Unit**, the **Power System Stabiliser** may be out of service.
- CC.A.6.2.5.8 Where a **Power System Stabiliser** is fitted to a **Pumped Storage Unit** it must function when the **Pumped Storage Unit** is in both generating and pumping modes.
- CC.A.6.2.6 Overall **Excitation System** Control Characteristics
- CC.A.6.2.6.1 The overall **Excitation System** shall include elements that limit the bandwidth of the output signal. The bandwidth limiting must be consistent with the speed of response requirements and ensure that the highest frequency of response cannot excite torsional oscillations on other plant connected to the network. A bandwidth of 0-5 Hz will be judged to be acceptable for this application.
- CC.A.6.2.6.2 The response of the **Automatic Voltage Regulator** combined with the **Power System Stabiliser** shall be demonstrated by injecting similar step signal disturbances into the **Automatic Voltage Regulator** reference as detailed in OC5A.2.2 and OC5.A.2.4. The **Automatic Voltage Regulator** shall include a facility to allow step injections into the **Automatic Voltage Regulator** voltage reference, with the **Onshore Generating Unit** operating at points specified by **NGET** (up to rated MVA output). The damping shall be judged to be adequate if the corresponding **Active Power** response to the disturbances decays within two cycles of oscillation.

- CC.A.6.2.6.3 A facility to inject a band limited random noise signal into the **Automatic Voltage Regulator** voltage reference shall be provided for demonstrating the frequency domain response of the **Power System Stabiliser**. The tuning of the **Power System Stabiliser** shall be judged to be adequate if the corresponding **Active Power** response shows improved damping with the **Power System Stabiliser** in combination with the **Automatic Voltage Regulator** compared with the **Automatic Voltage Regulator** alone over the frequency range 0.3Hz – 2Hz.
- CC.A.6.2.7 Under-Excitation Limiters
- CC.A.6.2.7.1 The security of the power system shall also be safeguarded by means of MVAR **Under Excitation Limiters** fitted to the generator **Excitation System**. The **Under Excitation Limiter** shall prevent the **Automatic Voltage Regulator** reducing the generator excitation to a level which would endanger synchronous stability. The **Under Excitation Limiter** shall operate when the excitation system is providing automatic control. The **Under Excitation Limiter** shall respond to changes in the **Active Power** (MW) and the **Reactive Power** (MVAR), and to the square of the generator voltage in such a direction that an increase in voltage will permit an increase in leading MVAR. The characteristic of the **Under Excitation Limiter** shall be substantially linear from no-load to the maximum **Active Power** output of the **Onshore Generating Unit** at any setting and shall be readily adjustable.
- CC.A.6.2.7.2 The performance of the **Under Excitation Limiter** shall be independent of the rate of change of the **Onshore Generating Unit** load and shall be demonstrated by testing as detailed in OC5.A.2.5. The resulting maximum overshoot in response to a step injection which operates the **Under Excitation Limiter** shall not exceed 4% of the **Onshore Generating Unit** rated MVA. The operating point of the **Onshore Generating Unit** shall be returned to a steady state value at the limit line and the final settling time shall not be greater than 5 seconds. When the step change in **Automatic Voltage Regulator** reference voltage is reversed, the field voltage should begin to respond without any delay and should not be held down by the **Under Excitation Limiter**. Operation into or out of the preset limit levels shall ensure that any resultant oscillations are damped so that the disturbance is within 0.5% of the **Onshore Generating Unit** MVA rating within a period of 5 seconds.
- CC.A.6.2.7.3 The **Generator** shall also make provision to prevent the reduction of the **Onshore Generating Unit** excitation to a level which would endanger synchronous stability when the **Excitation System** is under manual control.
- CC.A.6.2.8 Over-Excitation Limiters
- CC.A.6.2.8.1 The settings of the **Over-Excitation Limiter**, where it exists, shall ensure that the generator excitation is not limited to less than the maximum value that can be achieved whilst ensuring the **Onshore Generating Unit** is operating within its design limits. If the generator excitation is reduced following a period of operation at a high level, the rate of reduction shall not exceed that required to remain within any time dependent operating characteristics of the **Onshore Generating Unit**.
- CC.A.6.2.8.2 The performance of the **Over-Excitation Limiter**, where it exists, shall be demonstrated by testing as described in OC5.A.2.6. Any operation beyond the **Over-Excitation Limit** shall be controlled by the **Over-Excitation Limiter** without the operation of any **Protection** that could trip the **Onshore Generating Unit**.



CC.A.6.2.8.3 The **Generator** shall also make provision to prevent any over-excitation restriction of the generator when the **Excitation System** is under manual control, other than that necessary to ensure the **Onshore Generating Unit** is operating within its design limits.

# APPENDIX 7 - PERFORMANCE REQUIREMENTS FOR CONTINUOUSLY ACTING AUTOMATIC VOLTAGE CONTROL SYSTEMS FOR ONSHORE NON-SYNCHRONOUS GENERATING UNITS, ONSHORE DC CONVERTERS, ONSHORE POWER PARK MODULES AND OTSDUW PLANT AND APPARATUS AT THE INTERFACE POINT

## CC.A.7.1 Scope

CC.A.7.1.1 This Appendix sets out the performance requirements of continuously acting automatic voltage control systems for **Onshore Non-Synchronous Generating Units, Onshore DC Converters, Onshore Power Park Modules** and **OTSDUW Plant and Apparatus** at the **Interface Point** that must be complied with by the **User**. This Appendix does not limit any site specific requirements that may be included in a **Bilateral Agreement** where in **NGET's** reasonable opinion these facilities are necessary for system reasons.

CC.A.7.1.2 Proposals by **Generators** to make a change to the voltage control systems are required to be notified to **NGET** under the **Planning Code** (PC.A.1.2(b) and (c)) as soon as the **Generator** anticipates making the change. The change may require a revision to the **Bilateral Agreement**.

## CC.A.7.2 Requirements

CC.A.7.2.1 **NGET** requires that the continuously acting automatic voltage control system for the **Onshore Non-Synchronous Generating Unit, Onshore DC Converter** or **Onshore Power Park Module** or **OTSDUW Plant and Apparatus** shall meet the following functional performance specification. If a **Network Operator** has confirmed to **NGET** that its network to which an **Embedded Onshore Non-Synchronous Generating Unit, Onshore DC Converter, Onshore Power Park Module** or **OTSDUW Plant and Apparatus** is connected is restricted such that the full reactive range under the steady state voltage control requirements (CC.A.7.2.2) cannot be utilised, **NGET** may specify in the **Bilateral Agreement** alternative limits to the steady state voltage control range that reflect these restrictions. Where the **Network Operator** subsequently notifies **NGET** that such restriction has been removed, **NGET** may propose a **Modification** to the **Bilateral Agreement** (in accordance with the **CUSC** contract) to remove the alternative limits such that the continuously acting automatic voltage control system meets the following functional performance specification. All other requirements of the voltage control system will remain as in this Appendix.

### CC.A.7.2.2 Steady State Voltage Control

CC.A.7.2.2.1 The **Onshore Non-Synchronous Generating Unit, Onshore DC Converter, Onshore Power Park Module** or **OTSDUW Plant and Apparatus** shall provide continuous steady state control of the voltage at the **Onshore Grid Entry Point** (or **Onshore User System Entry Point** if **Embedded**) (or the **Interface Point** in the case of **OTSDUW Plant and Apparatus**) with a **Setpoint Voltage** and **Slope** characteristic as illustrated in Figure CC.A.7.2.2a. It should be noted that where the **Reactive Power** capability requirement of a directly connected **Onshore Non-Synchronous Generating Unit, Onshore DC Converter, Onshore Power Park Module** in Scotland, or **OTSDUW Plant and Apparatus** in Scotland as specified in CC.6.3.2 (c), is not at the **Onshore Grid Entry Point** or **Interface Point**, the values of  $Q_{min}$  and  $Q_{max}$  shown in this figure will be as modified by the 33/132kV or 33/275kV or 33/400kV transformer.

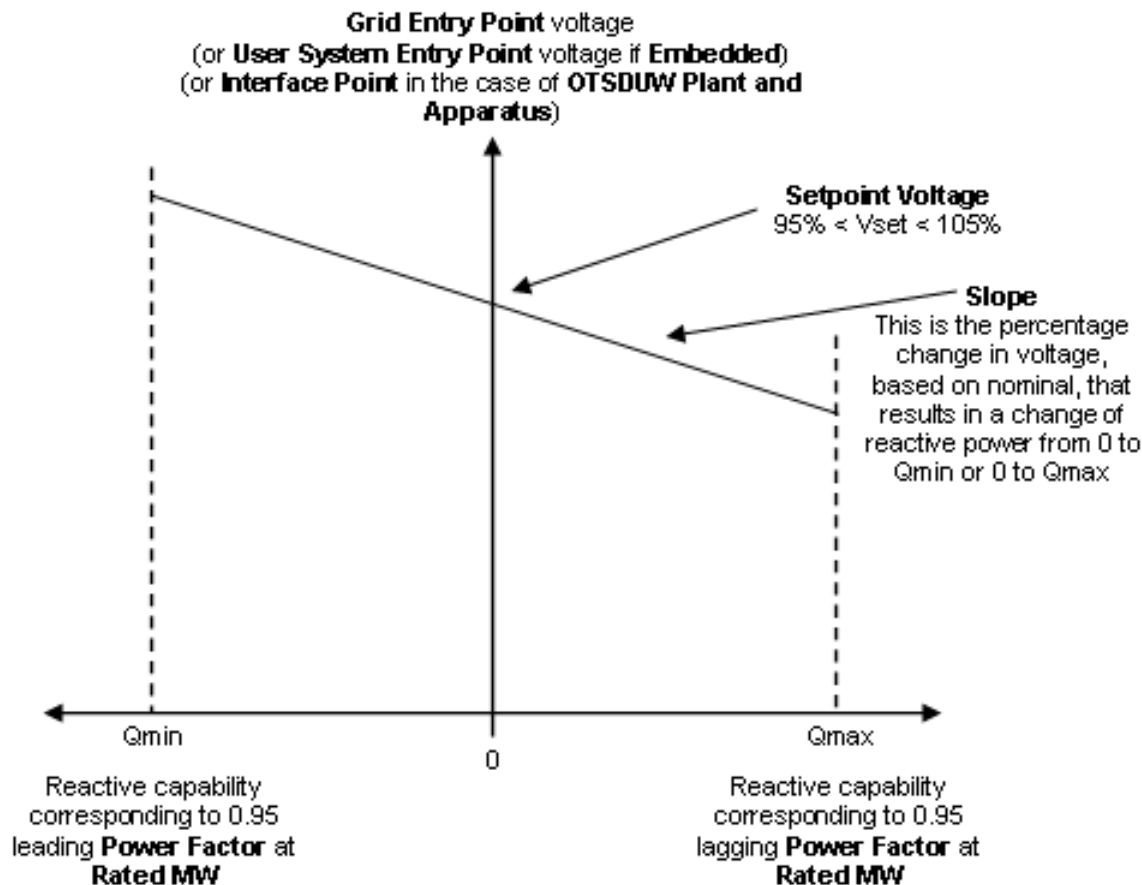

Figure CC.A.7.2.2a

CC.A.7.2.2.2 The continuously acting automatic control system shall be capable of operating to a **Setpoint Voltage** between 95% and 105% with a resolution of 0.25% of the nominal voltage. For the avoidance of doubt values of 95%, 95.25%, 95.5% ... may be specified, but not intermediate values. The initial **Setpoint Voltage** will be 100%. The tolerance within which this **Setpoint Voltage** shall be achieved is specified in BC2.A.2.6. For the avoidance of doubt, with a tolerance of 0.25% and a Setpoint Voltage of 100%, the achieved value shall be between 99.75% and 100.25%. **NGET** may request the **Generator** to implement an alternative **Setpoint Voltage** within the range of 95% to 105%. For **Embedded Generators** the **Setpoint Voltage** will be discussed between **NGET** and the relevant **Network Operator** and will be specified to ensure consistency with CC.6.3.4.

CC.A.7.2.2.3 The **Slope** characteristic of the continuously acting automatic control system shall be adjustable over the range 2% to 7% (with a resolution of 0.5%). For the avoidance of doubt values of 2%, 2.5%, 3% may be specified, but not intermediate values. The initial **Slope** setting will be 4%. The tolerance within which this **Slope** shall be achieved is specified in BC2.A.2.6. For the avoidance of doubt, with a tolerance of 0.5% and a **Slope** setting of 4%, the achieved value shall be between 3.5% and 4.5%. **NGET** may request the **Generator** to implement an alternative slope setting within the range of 2% to 7%. For **Embedded Generators** the **Slope** setting will be discussed between **NGET** and the relevant **Network Operator** and will be specified to ensure consistency with CC.6.3.4.

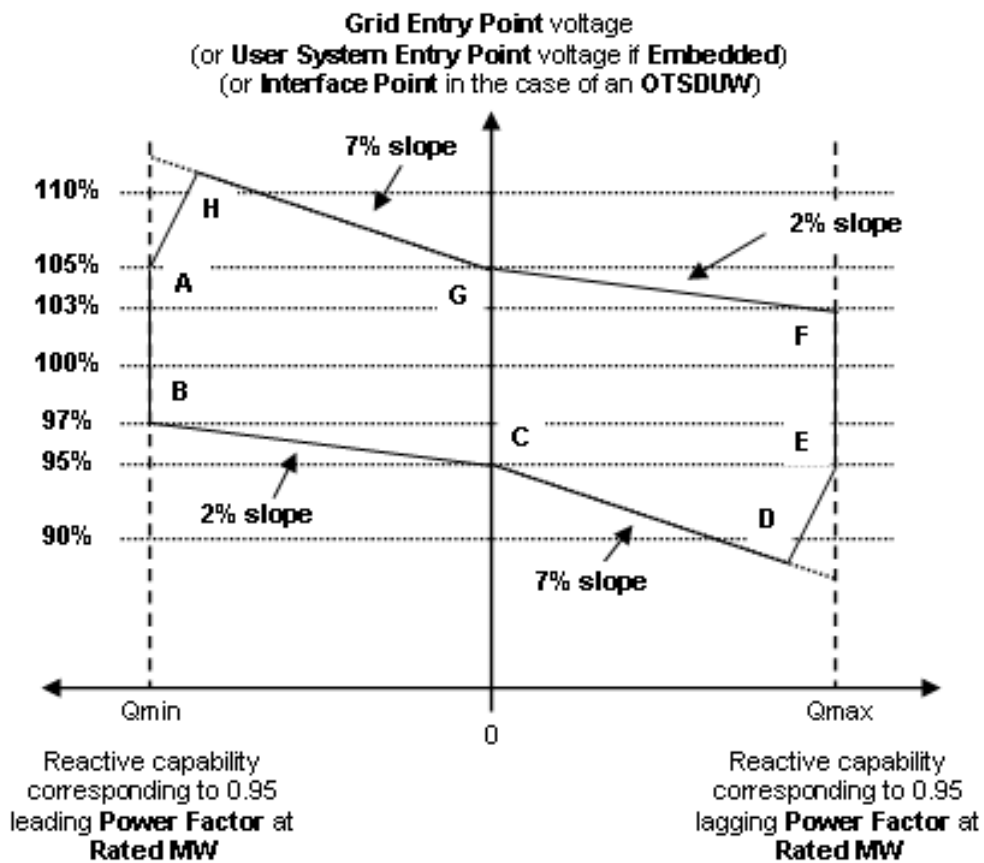

Figure CC.A.7.2.2b

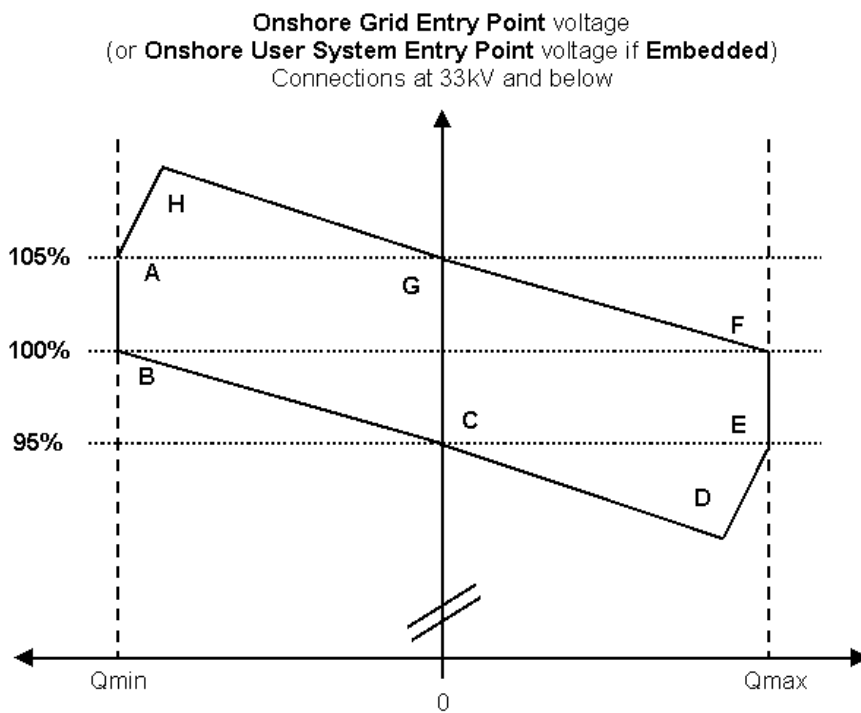

Figure CC.A.7.2.2c

- CC.A.7.2.2.4 Figure CC.A.7.2.2b shows the required envelope of operation for **Onshore Non-Synchronous Generating Units, Onshore DC Converters, OTSDUW Plant and Apparatus** and **Onshore Power Park Modules** except for those **Embedded** at 33kV and below or directly connected to the **National Electricity Transmission System** at 33kV and below. Figure CC.A.7.2.2c shows the required envelope of operation for **Onshore Non-Synchronous Generating Units, Onshore DC Converters** and **Onshore Power Park Modules Embedded** at 33kV and below or directly connected to the **National Electricity Transmission System** at 33kV and below. Where the **Reactive Power** capability requirement of a directly connected **Onshore Non-Synchronous Generating Unit, Onshore DC Converter, OTSDUW Plant and Apparatus** or **Onshore Power Park Module** in Scotland, as specified in CC.6.3.2 (c), is not at the **Onshore Grid Entry Point** or **Interface Point** in the case of **OTSDUW Plant and Apparatus**, the values of  $Q_{min}$  and  $Q_{max}$  shown in this figure will be as modified by the 33/132kV or 33/275kV or 33/400kV transformer. The enclosed area within points ABCDEFGH is the required capability range within which the **Slope** and **Setpoint Voltage** can be changed.
- CC.A.7.2.2.5 Should the operating point of the **Onshore Non-Synchronous Generating Unit, Onshore DC Converter, OTSDUW Plant and Apparatus** or **Onshore Power Park Module** deviate so that it is no longer a point on the operating characteristic (figure CC.A.7.2.2a) defined by the target **Setpoint Voltage** and **Slope**, the continuously acting automatic voltage control system shall act progressively to return the value to a point on the required characteristic within 5 seconds.
- CC.A.7.2.2.6 Should the **Reactive Power** output of the **Onshore Non-Synchronous Generating Unit, Onshore DC Converter, OTSDUW Plant and Apparatus** or **Onshore Power Park Module** reach its maximum lagging limit at a **Onshore Grid Entry Point** voltage (or **Onshore User System Entry Point** voltage if **Embedded** or **Interface Point** in the case of **OTSDUW Plant and Apparatus**) above 95%, the **Onshore Non-Synchronous Generating Unit, Onshore DC Converter, OTSDUW Plant and Apparatus** or **Onshore Power Park Module** shall maintain maximum lagging **Reactive Power** output for voltage reductions down to 95%. This requirement is indicated by the line EF in figures CC.A.7.2.2b and CC.A.7.2.2c. Should the **Reactive Power** output of the **Onshore Non-Synchronous Generating Unit, Onshore DC Converter, OTSDUW Plant and Apparatus** or **Onshore Power Park Module** reach its maximum leading limit at a **Onshore Grid Entry Point** voltage (or **Onshore User System Entry Point** voltage if **Embedded** or **Interface Point** in the case of **OTSDUW Plant and Apparatus**) below 105%, the **Onshore Non-Synchronous Generating Unit, Onshore DC Converter, OTSDUW Plant and Apparatus** or **Onshore Power Park Module** shall maintain maximum leading **Reactive Power** output for voltage increases up to 105%. This requirement is indicated by the line AB in figures CC.A.7.2.2b and CC.A.7.2.2c.

- CC.A.7.2.2.7 For **Onshore Grid Entry Point** voltages (or **Onshore User System Entry Point** voltages if Embedded or **Interface Point** voltages) below 95%, the lagging **Reactive Power** capability of the **Onshore Non-Synchronous Generating Unit, Onshore DC Converter, OTSDUW Plant and Apparatus** or **Onshore Power Park Module** should be that which results from the supply of maximum lagging reactive current whilst ensuring the current remains within design operating limits. An example of the capability is shown by the line DE in figures CC.A.7.2.2b and CC.A.7.2.2c. For **Onshore Grid Entry Point** voltages (or **User System Entry Point** voltages if Embedded or **Interface Point** voltages) above 105%, the leading **Reactive Power** capability of the **Onshore Non-Synchronous Generating Unit, Onshore DC Converter, OTSDUW Plant and Apparatus** or **Onshore Power Park Module** should be that which results from the supply of maximum leading reactive current whilst ensuring the current remains within design operating limits. An example of the capability is shown by the line AH in figures CC.A.7.2.2b and CC.A.7.2.2c. Should the **Reactive Power** output of the **Onshore Non-Synchronous Generating Unit, Onshore DC Converter, OTSDUW Plant and Apparatus** or **Onshore Power Park Module** reach its maximum lagging limit at an **Onshore Grid Entry Point** voltage (or **Onshore User System Entry Point** voltage if Embedded or **Interface Point** in the case of **OTSDUW Plant and Apparatus**) below 95%, the **Onshore Non-Synchronous Generating Unit, Onshore DC Converter** or **Onshore Power Park Module** shall maintain maximum lagging reactive current output for further voltage decreases. Should the **Reactive Power** output of the **Onshore Non-Synchronous Generating Unit, Onshore DC Converter, OTSDUW Plant and Apparatus** or **Onshore Power Park Module** reach its maximum leading limit at a **Onshore Grid Entry Point** voltage (or **User System Entry Point** voltage if Embedded or **Interface Point** voltage in the case of an **OTSDUW Plant and Apparatus**) above 105%, the **Onshore Non-Synchronous Generating Unit, Onshore DC Converter, OTSDUW Plant and Apparatus** or **Onshore Power Park Module** shall maintain maximum leading reactive current output for further voltage increases.
- CC.A.7.2.2.8 All **OTSDUW Plant and Apparatus** must be capable of enabling **Users** undertaking **OTSDUW** to comply with an instruction received from **NGET** relating to a variation of the **Setpoint Voltage** at the **Interface Point** within 2 minutes of such instruction being received.
- CC.A.7.2.2.9 For **OTSDUW Plant and Apparatus** connected to a **Network Operator's System** where the **Network Operator** has confirmed to **NGET** that its **System** is restricted in accordance with CC.A.7.2.1, clause CC.A.7.2.2.8 will not apply unless **NGET** can reasonably demonstrate that the magnitude of the available change in **Reactive Power** has a significant effect on voltage levels on the **Onshore National Electricity Transmission System**.
- CC.A.7.2.3 Transient Voltage Control
- CC.A.7.2.3.1 For an on-load step change in **Onshore Grid Entry Point** or **Onshore User System Entry Point** voltage, or in the case of **OTSDUW Plant and Apparatus** an on-load step change in **Transmission Interface Point** voltage, the continuously acting automatic control system shall respond according to the following minimum criteria:
- (i) the **Reactive Power** output response of the **Onshore Non-Synchronous Generating Unit, Onshore DC Converter, OTSDUW Plant and Apparatus** or **Onshore Power Park Module** shall commence within 0.2 seconds of the application of the step. It shall progress linearly although variations from a linear characteristic shall be acceptable provided that the MVar seconds delivered at any time up to 1 second are at least those that would result from the response shown in figure CC.A.7.2.3.1a.

- (ii) the response shall be such that, for a sufficiently large step, 90% of the full reactive capability of the **Onshore Non-Synchronous Generating Unit, Onshore DC Converter, OTSDUW Plant and Apparatus** or **Onshore Power Park Module**, as required by CC.6.3.2 (or, if appropriate, CC.A.7.2.2.6 or CC.A.7.2.2.7), will be produced within 1 second.
- (iii) the magnitude of the **Reactive Power** output response produced within 1 second shall vary linearly in proportion to the magnitude of the step change.
- (iv) the settling time shall be no greater than 2 seconds from the application of the step change in voltage and the peak to peak magnitude of any oscillations shall be less than 5% of the change in steady state **Reactive Power** within this time.
- (v) following the transient response, the conditions of CC.A.7.2.2 apply.

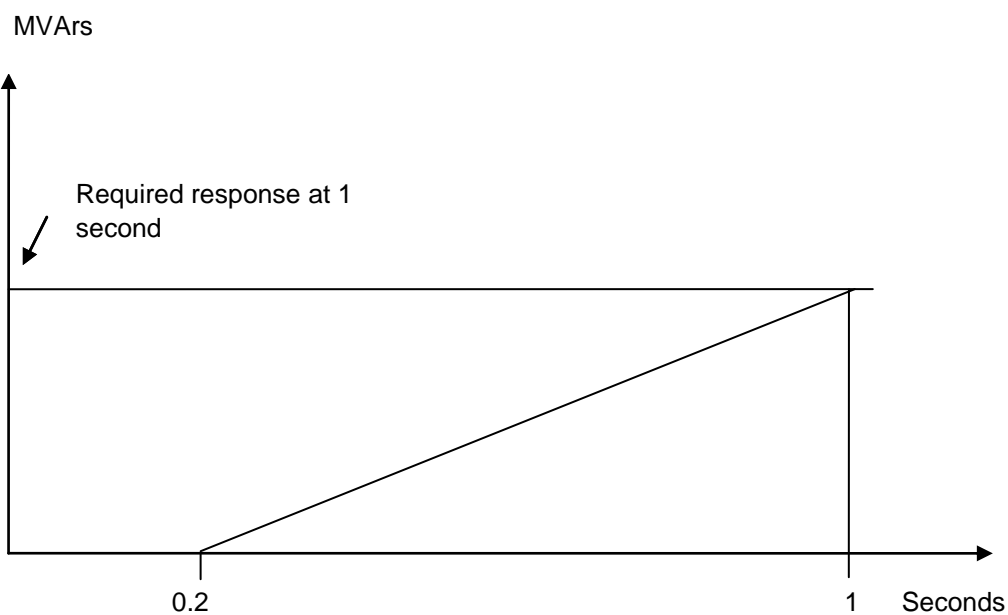

Figure CC.A.7.2.3.1a

#### CC.A.7.2.4 Power Oscillation Damping

CC.A.7.2.4.1 The requirement for the continuously acting voltage control system to be fitted with a **Power System Stabiliser (PSS)** shall be specified in the **Bilateral Agreement** if, in **NGET's** view, this is required for system reasons. However if a **Power System Stabiliser** is included in the voltage control system its settings and performance shall be agreed with **NGET** and commissioned in accordance with BC2.11.2. To allow assessment of the performance before on-load commissioning the **Generator** will provide to **NGET** a report covering the areas specified in CP.A.3.2.2.

#### CC.A.7.2.5 Overall Voltage Control System Characteristics

CC.A.7.2.5.1 The continuously acting automatic voltage control system is required to respond to minor variations, steps, gradual changes or major variations in **Onshore Grid Entry Point** voltage (or **Onshore User System Entry Point** voltage if **Embedded** or **Interface Point** voltage in the case of **OTSDUW Plant and Apparatus**).

- CC.A.7.2.5.2 The overall voltage control system shall include elements that limit the bandwidth of the output signal. The bandwidth limiting must be consistent with the speed of response requirements and ensure that the highest frequency of response cannot excite torsional oscillations on other plant connected to the network. A bandwidth of 0-5Hz would be judged to be acceptable for this application. All other control systems employed within the **Onshore Non-Synchronous Generating Unit, Onshore DC Converter, OTSDUW Plant and Apparatus** or **Onshore Power Park Module** should also meet this requirement
- CC.A.7.2.5.3 The response of the voltage control system (including the **Power System Stabiliser** if employed) shall be demonstrated by testing in accordance with OC5A.A.3.

< END OF CONNECTION CONDITIONS >



# COMPLIANCE PROCESSES

(CP)

## CONTENTS

(This contents page does not form part of the Grid Code)

| <u>Paragraph No/Title</u>                                | <u>Page Number</u>      |
|--|-------------------------|
| CP.1 INTRODUCTION .....                                  | 2                       |
| CP.2 OBJECTIVE.....                                      | 2                       |
| CP.3 SCOPE .....   | 2                       |
| CP.4 CONNECTION PROCESS.....                             | 3                       |
| CP.5 ENERGISATION OPERATIONAL NOTIFICATION .....         | 3                       |
| CP.6 INTERIM OPERATIONAL NOTIFICATION.....               | 4                       |
| CP.7 FINAL OPERATIONAL NOTIFICATION .....                | <del>6</del> <u>7</u>   |
| CP.8 LIMITED OPERATIONAL NOTIFICATION .....              | <del>8</del> <u>9</u>   |
| CP.9 PROCESSES RELATING TO DEROGATIONS .....             | 11                      |
| CP.10 MANUFACTURER'S DATA & PERFORMANCE REPORT .....     | <del>11</del> <u>12</u> |
| APPENDIX 1 - ILLUSTRATIVE PROCESS DIAGRAMS .....         | 14                      |
| APPENDIX 2 - USER SELF CERTIFICATION OF COMPLIANCE ..... | <del>18</del> <u>19</u> |
| APPENDIX 3 - SIMULATION STUDIES .....                    | <del>19</del> <u>20</u> |

CP.1 INTRODUCTION

CP.1.1 The **Compliance Processes** ("CP") specifies:

the process (leading to an **Energisation Operational Notification**) which must be followed by **NGET** and any **User** to demonstrate its compliance with the Grid Code in relation to its **Plant** and **Apparatus** (including OTSUA) prior to the relevant **Plant** and **Apparatus** (including any OTSUA) being energised.

the process (leading to an **Interim Operational Notification** and **Final Operational Notification**) which must be followed by **NGET** and any **Generator** or **DC Converter Station** owner to demonstrate its compliance with the Grid Code in relation to its **Plant** and **Apparatus** (including any dynamically controlled OTSUA). This process shall be followed prior to and during the course of the relevant **Plant** and **Apparatus** (including OTSUA) being energised and **Synchronised**.

the process (leading to a **Limited Operational Notification**) which must be followed by **NGET** and each **Generator** and **DC Converter Station** owner where any of its **Plant** and/or **Apparatus** (including any OTSUA) becomes unable to comply with relevant provisions of the Grid Code, and where applicable with Appendices F1 to F5 (and in the case of OTSUA, Appendices OF1 to OF5 of the Bilateral Agreement). This process also includes when changes or **Modifications** are made to **Plant** and/or **Apparatus** (including OTSUA). This process applies to such **Plant** and/or **Apparatus** after the **Plant** and/or **Apparatus** has become **Operational** and until **Disconnected** from the **Total System** (or until, in the case of OTSUA, the OTSUA Transfer Time), when changes or **Modifications** are made.

CP.1.2 As used in this CP references to OTSUA means OTSUA to be connected or connected to the National Electricity Transmission System prior to the OTSUA Transfer Time.

CP.1.3 Where the Generator or DC Converter Station Owner and/or NGET are required to apply for a derogation from the Authority, this is not in respect of the OTSUA

CP.2 OBJECTIVE

CP.2.1 The objective of the **CP** is to ensure that there is a clear and consistent process for demonstration of compliance by **Users** with the **Connection Conditions** and **Bilateral Agreement** which are similar for all **Users** of an equivalent category and will enable **NGET** to comply with its statutory and **Transmission Licence** obligations.

CP.2.2 Provisions of the **CP** which apply in relation to **OTSDUW** and **OTSUA** shall (in any particular case) apply up to the **OTSUA Transfer Time**, whereupon such provisions shall (without prejudice to any prior non-compliance) cease to apply.

CP.2.3 In relation to **OTSDUW**, provisions otherwise to be contained in a **Bilateral Agreement** may be contained in the **Construction Agreement**, and accordingly a reference in the **CP** to a relevant **Bilateral Agreement** includes the relevant **Construction Agreement**.

CP.3 SCOPE

CP.3.1 The **CP** applies to **NGET** and to **Users**, which in the **CP** means:

- (a) **Generators** (other than in relation to **Embedded Small Power Stations** or **Embedded Medium Power Stations** not subject to a **Bilateral Agreement**) including those undertaking **OTSDUW**.

- (b) **Network Operators;**
- (c) **Non-Embedded Customers;**
- (d) **DC Converter Station** owners (other than those which only have **Embedded DC Converter Stations** not subject to a **Bilateral Agreement**).

CP.3.2 The above categories of **User** will become bound by the **CP** prior to them generating, distributing, supplying or consuming, or in the case of OTSUA, transmitting, as the case may be, and references to the various categories should, therefore, be taken as referring to them in that prospective role as well as to **Users** actually connected.

CP.4 CONNECTION PROCESS

CP.4.1 The **CUSC Contract(s)** contain certain provisions relating to the procedure for connection to the **National Electricity Transmission System** or, in the case of **Embedded Power Stations** or **Embedded DC Converter Stations**, becoming operational and include provisions to be complied with by **Users** prior to and during the course of **NGET** notifying the **User** that it has the right to become operational. In addition to such provisions this **CP** sets out in further detail the processes to be followed to demonstrate compliance. Whilst this CP does not expressly address the processes to be followed in the case of OTSUA connecting to a Network Operator's User System prior to the OTSUA Transfer Time, the processes to be followed by NGET and the Generator in respect of OTSUA in such circumstances shall be consistent with those set out below by reference OTSUA directly connected to the National Electricity Transmission System.

CP.4.2 The provisions contained in CP.5 to CP.7 detail the process to be followed in order for the **User's Plant** and **Apparatus** (including **OTSUA**) to become operational. This process includes **EON** (energisation) **ION** (interim synchronising) and **FON** (final).

CP.4.2.1 The provisions contained in CP.5 relate to the connection and energisation of **User's Plant** and **Apparatus** (including **OTSUA**) to the **National Electricity Transmission System** or where **Embedded**, to a **User's System** and is shown diagrammatically at CP.A.1.1.

CP.4.2.2 The provisions contained in CP.6 and CP.7 provide the process for **Generators** and **DC Converter Station** owners to demonstrate compliance with the Grid Code and with, where applicable, the **CUSC Contract(s)** prior to and during the course of such **Generator's** or **DC Converter Station** owner's **Plant** and **Apparatus** (including **OTSUA** becoming operational and is shown diagrammatically at CP.A.1.2 and CP.A.1.3.

CP.4.2.3 The provisions contained in CP.8 detail the process to be followed when:

- (a) a **Generator** or **DC Converter Station** owner's **Plant** and/or **Apparatus** (including the OTSUA) is unable to comply with any provisions of the Grid Code and **Bilateral Agreement**; or,
- (b) following any notification by a **Generator** or a **DC Converter Station** owner under the **PC** of any change to its **Plant** and **Apparatus** (including any OTSUA); or,
- (c) a **Modification** to a **Generator** or a **DC Converter Station** owner's **Plant** and/or **Apparatus**.

The process is shown diagrammatically at Appendix CP.A. 1.31.4 for condition (a) and Appendix CP.A. 1.41.5 for conditions (b) and (c)

CP.4.3 Embedded Medium Power Stations not subject to a Bilateral Agreement and Embedded DC Converter Stations not subject to a Bilateral Agreement

CP.4.3.1 For the avoidance of doubt the process in this **CP** does not apply to **Embedded Medium Power Stations** not subject to a **Bilateral Agreement** and **Embedded DC Converter Stations** not subject to a **Bilateral Agreement**.

CP.5 ENERGISATION OPERATIONAL NOTIFICATION

CP.5.1 The following provisions apply in relation to the issue of an **Energisation Operational Notification**.

CP.5.1.1 Certain provisions relating to the connection and energisation of the **User's Plant** and **Apparatus** at the **Connection Site** and OTSUA at the Transmission Interface Point and in certain cases of **Embedded Plant** and **Apparatus** are specified in the **CUSC** and/or **CUSC Contract(s)**. For other **Embedded Plant** and **Apparatus** the **Distribution Code**, the **DCUSA** and the **Embedded Development Agreement** for the connection specify equivalent provisions. Further detail on this is set out in CP.5 below.

CP.5.2 The items for submission prior to the issue of an **Energisation Operational Notification** are set out in CC.5.2

CP.5.3 In the case of a **Generator** or **DC Converter Station** owner the items referred to in CC.5.2 shall be submitted using the **User Data File Structure**.

CP.5.4 Not less than 28 days, or such shorter period as may be acceptable in **NGET's** reasonable opinion, prior to the **User** wishing to energise its **Plant** and Apparatus (including passive OTSUA) for the first time the **User** will submit to **NGET** a Certificate of Readiness to Energise **High Voltage Equipment** which specifies the items of **Plant** and **Apparatus** (including OTSUA) ready to be energised in a form acceptable to **NGET**.

CP.5.5 If the relevant obligations under the provisions of the **CUSC** and/or **CUSC Contract(s)** and the conditions of CP.5 have been completed to **NGET's** reasonable satisfaction then **NGET** shall issue an **Energisation Operational Notification**. Any dynamically controlled reactive compensation OTSUA (including Statcoms or Static Var Compensators) shall not be Energised until the appropriate Interim Operational Notification has been issued in accordance with CP.6.

CP.6 INTERIM OPERATIONAL NOTIFICATION

CP.6.1 The following provisions apply in relation to the issue of an **Interim Operational Notification**.

CP.6.2 Not less than 28 days, or such shorter period as may be acceptable in **NGET's** reasonable opinion, prior to the **Generator** or **DC Converter Station** owner wishing to **Synchronise** its **Plant** and **Apparatus** or dynamically controlled OTSUA for the first time the **Generator** or **DC Converter Station** owner will:

(i) submit to **NGET** a **Notification of User's Intention to Synchronise**;  
and

(ii) submit to **NGET** the items referred to at CP.6.3.

CP.6.3 Items for submission prior to issue of the **Interim Operational Notification**.

CP.6.3.1 Prior to the issue of an **Interim Operational Notification** in respect of the User's Plant and Apparatus or dynamically controlled OTSUA,

the **Generator** or **DC Converter Station** owner must submit to **NGET** to **NGET's** satisfaction:

- (a) updated **Planning Code** data (both **Standard Planning Data** and **Detailed Planning Data**), with any estimated values assumed for planning purposes confirmed or, where practical, replaced by validated actual values and by updated estimates for the future and by updated forecasts for **Forecast Data** items such as **Demand**;
- (b) details of any special **Power Station, Generating Unit(s), Power Park Module(s)** or **DC Converter Station(s)** protection as applicable. This may include Pole Slipping protection and islanding protection schemes;
- (c) any items required by CP.5.2, updated by the **User** as necessary;
- (d) simulation study provisions of Appendix CP.A.3 and the results demonstrating compliance with Grid Code requirements of:

PC.A.5.4.2

PC.A.5.4.3.2,

CC.6.3.4,

CC.6.3.7(c)(i),

CC.6.3.15,

CC.A.6.2.5.6,

CC.A.7.2.3.1,

as applicable to the **Power Station, Generating Unit(s), Power Park Module(s)** or **DC Converter(s)** or dynamically controlled OTSUA unless agreed otherwise by **NGET**;

- (e) a detailed schedule of the tests and the procedures for the tests required to be carried out by the **Generator** or **DC Converter Station** owner under CP.7.2 to demonstrate compliance with relevant Grid Code requirements. Such schedule to be consistent with Appendix OC5.A.2 (in the case of **Generating Units** other than **Power Park Modules**) or Appendix OC5.A.3 (in the case of **Generating Units** comprising **Power Park Modules** and OTSUA as applicable); and
- (f) an interim **Compliance Statement** and a **User Self Certification of Compliance** completed by the **User** (including any **Unresolved Issues**) against the relevant Grid Code requirements including details of any requirements that the **Generator** or **DC Converter Station** owner has identified that will not or may not be met or demonstrated.

CP.6.3.2 The items referred to in CP.6.3 shall be submitted by the **Generator** or **DC Converter Station** owner using the **User Data File Structure**.

CP.6.4 No **Generating Unit, CCGT Module, Power Park Module** or **DC Converter** or dynamically controlled OTSUA shall be **Synchronised** to the **Total System** (and for the avoidance of doubt, dynamically controlled OTSUA will not be able to transmit), until the later of:

- (a) the date specified by **NGET** in the **Interim Operational Notification** issued in respect of the **Generating Unit(s), CCGT Module(s), Power Park Module(s)** or **DC Converter(s)** or dynamically controlled OTSUA; and,
- (b) if **Embedded**, the date of receipt of a confirmation from the **Network Operator** in whose **System** the **Plant** and **Apparatus** is connected that it is acceptable to the **Network Operator** that the **Plant** and **Apparatus** be connected and **Synchronised**; and,

(c) in the case of **Synchronous Generating Unit(s)** only after the date of receipt by **Generator** of written confirmation from **NGET** that the **Generating Unit** or **CCGT Module** as applicable has completed the following tests to demonstrate compliance with the relevant provisions of the **Connection Conditions** to **NGET's** satisfaction:

- (i) those tests required to establish the open and short circuit saturation characteristics of the **Generating Unit** (as detailed in Appendix OC5.A.2.3) to enable assessment of the short circuit ratio in accordance with CC.6.3.2. Such tests may be carried out at a location other than the **Power Station** site; and
- (ii) open circuit step response tests (as detailed in Appendix OC5.A.2.2) to demonstrate compliance with CC.A.6.2.4.1.

CP.6.5 **NGET** shall assess the schedule of tests submitted by the **Generator** or **DC Converter Station** owner with the **Notification of User's Intention to Synchronise** under CP.6.1 and shall determine whether such schedule has been completed to **NGET's** satisfaction.

CP.6.6 When the requirements of CP.6.2 to CP.6.5 have been met, **NGET** will notify the **Generator** or **DC Converter Station** owner that the:

**Generating Unit,**

**CCGT Module,**

**Power Park Module,**

Dynamically controlled OTSUA or

**DC Converter,**

as applicable may (subject to the **Generator** or **DC Converter Station** owner having fulfilled the requirements of CP.6.3 where that applies) be **Synchronised** to the **Total System** through the issue of an **Interim Operational Notification**. Where the **Generator** is undertaking OTSDUW then the **Interim Operational Notification** will be in two parts, with the "**Interim Operational Notification Part A**" applicable to the **OTSUA** and the "**Interim Operational Notification Part B**" applicable to the **Users Plant and Apparatus**. For the avoidance of doubt, the **Interim Operational Notification Part A** and the **Interim Operational Notification Part B** can be issued together or at different times. In respect of an **Embedded Power Station** or **Embedded DC Converter Station** (other than a **Embedded Medium Power Stations** not subject to a **Bilateral Agreement** and **Embedded DC Converter Stations** not subject to a **Bilateral Agreement**), **NGET** will notify the **Network Operator** that an **Interim Operational Notification** has been issued.

CP.6.6.1 The **Interim Operational Notification** will be time limited, the expiration date being specified at the time of issue. The **Interim Operational Notification** may be renewed by **NGET**.

CP.6.6.2 The **Generator** or **DC Converter Station** owner must operate the **Generating Unit, CCGT Module, Power Park Module, OTSUA** or **DC Converter** in accordance with the terms, arising from the **Unresolved Issues**, of the **Interim Operational Notification**. Where practicable, **NGET** will discuss such terms with the **Generator** or **DC Converter Station** owner prior to including them in the **Interim Operational Notification**.

CP.6.6.3 The **Interim Operational Notification** will include the following limitations:

- (a) In the case of **OTSUA**, the **Interim Operational Notification Part A** permits **Synchronisation** of the dynamically controlled **OTSUA** to the **Total System** only for the purposes of active control of voltage and reactive power and not for the purpose of exporting **Active Power**.

- (b) In the case of a **Power Park Module** the **Interim Operational Notification** (and where **OTSDUW Arrangements** apply, this reference will be to the **Interim Operational Notification Part B**) will limit the proportion of the **Power Park Module** which can be simultaneously **Synchronised** to the **Total System** such that neither of the following figures is exceeded:
- (i) 20% of the **Registered Capacity** of the **Power Park Module** (or the output of a single **Power Park Unit** where this exceeds 20% of the **Power Station's Registered Capacity**); nor
  - (ii) 50MW
- until the **Generator** has completed the voltage control tests (detailed in OC5.A.3.2) (including in respect of any dynamically controlled **OTSUA**) to **NGET's** reasonable satisfaction. Following successful completion of this test each additional **Power Park Unit** should be included in the voltage control scheme as soon as is technically possible (unless **NGET** agrees otherwise).
- (b) In the case of a **Power Park Module** with a **Registered Capacity** greater or equal to 100MW, the **Interim Operational Notification** (and where **OTSDUW Arrangements** apply, this reference will be to the **Interim Operational Notification Part B**) will limit the proportion of the **Power Park Module** which can be simultaneously **Synchronised** to the **Total System** to 70% of **Registered Capacity** until the **Generator** has completed the **Limited Frequency Sensitive Mode** control tests with at least 50% of the **Registered Capacity** of the **Power Park Module** in service (detailed in OC5.A.3.3) to **NGET's** reasonable satisfaction.
- (c) In the case of a **Synchronous Generating Unit** employing a static **Excitation System** the **Interim Operational Notification** (and where **OTSDUW Arrangements** apply, this reference will be to the **Interim Operational Notification Part B**) may if applicable limit the maximum **Active Power** output and reactive power output of the **Synchronous Generating Unit** or **CCGT module** prior to the successful commissioning of the **Power System Stabiliser** to **NGET's** satisfaction.

CP.6.6.4 When a **User** and **NGET** are acting/operating in accordance with the provisions of a **Interim Operational Notification**, whilst it is in force, the relevant provisions of the Grid Code to which that **Interim Operational Notification** relates will not apply to the **User** or **NGET** to the extent and for the period set out in the **Interim Operational Notification**.

CP.6.7 Other than **Unresolved Issues** that are subject to tests required under CP.7.2 to be witnessed by **NGET**, the **Generator** or **DC Converter Station** owner must resolve any **Unresolved Issues** prior to the commencement of the tests, unless **NGET** agrees to a later resolution. The **Generator** or **DC Converter Station** owner must liaise with **NGET** in respect of such resolution. The tests that may be witnessed by **NGET** are specified in CP.7.2.

CP.6.8 Not less than 28 days, or such shorter period as may be acceptable in **NGET's** reasonable opinion, prior to the **Generator** or **DC Converter Station** owner wishing to commence tests required under CP.7 to be witnessed by **NGET**, the **Generator** or **DC Converter Station** owner will notify **NGET** that the **Generating Unit(s)**, **CCGT Module(s)**, **Power Park Module(s)** or **DC Converter(s)** as applicable is ready to commence such tests.

CP.6.9 The items referred to at CP.7.3 shall be submitted by the **Generator** or the **DC Converter Station** owner after successful completion of the tests required under CP.7.2.

CP.7. FINAL OPERATIONAL NOTIFICATION

- CP.7.1 The following provisions apply in relation to the issue of a **Final Operational Notification**.
- CP.7.2 Tests to be carried out prior to issue of the **Final Operational Notification**
- CP.7.2.1 Prior to the issue of a **Final Operational Notification** the **Generator** or **DC Converter Station** owner must have completed the tests specified in this CP.7.2.2 to **NGET's** satisfaction to demonstrate compliance with the relevant Grid Code provisions.
- CP.7.2.2 In the case of any **Generating Unit, CCGT Module, Power Park Module, OTSUA (if applicable)** and **DC Converter** these tests will comprise one or more of the following:
- (a) reactive capability tests to demonstrate that the **Generating Unit, CCGT Module, Power Park Module, OTSUA (if applicable)** and **DC Converter** can meet the requirements of CC.6.3.2. These may be witnessed by **NGET** on site if there is no metering to the **NGET Control Centre**.
  - (b) voltage control system tests to demonstrate that the **Generating Unit, CCGT Module, Power Park Module, OTSUA (if applicable)** and **DC Converter** can meet the requirements of CC.6.3.6, CC.6.3.8 and, in the case of **Power Park Module, OTSUA (if applicable)** and **DC Converter**, the requirements of CC.A.7 and, in the case of **Generating Unit** and **CCGT Module**, the requirements of CC.A.6, and any terms specified in the **Bilateral Agreement** as applicable. These tests may also be used to validate the **Excitation System** model (PC.A.5.3) or voltage control system model (PC.A.5.4) as applicable. These tests may be witnessed by **NGET**.
  - (c) governor or frequency control system tests to demonstrate that the **Generating Unit, CCGT Module, OTSUA (if applicable)** and **Power Park Module** can meet the requirements of CC.6.3.6, CC.6.3.7, where applicable CC.A.3, and BC.3.7. The results will also validate the **Mandatory Service Agreement** required by CC.8.1. These tests may also be used to validate the Governor model (PC.A.5.3) or frequency control system model (PC.A.5.4) as applicable. These tests may be witnessed by **NGET**.
  - (d) fault ride through tests in respect of a **Power Station** with a **Registered Capacity** of 100MW or greater, comprised of one or more **Power Park Modules**, to demonstrate compliance with CC.6.3.15 (a), (b) and (c), CC.A.4.1, CC.A.4.2 and CC.A.4.3. Where test results from a **Manufacturers Data & Performance Report** as defined in CP.10 have been accepted this test will not be required.
  - (e) any further tests reasonably required by **NGET** and agreed with the **User** to demonstrate any aspects of compliance with the Grid Code and the **CUSC Contracts**.
- CP.7.2.3 **NGET's** preferred range of tests to demonstrate compliance with the **CC** are specified in Appendix OC5.A.2 (in the case of **Generating Units** other than **Power Park Modules**) or Appendix OC5.A.3 (in the case of **Generating Units** comprising **Power Park Modules** or **OTSUA if applicable**) or Appendix OC5.A.4 (in the case of **DC Converters**) and are to be carried out by the **User** with the results of each test provided to **NGET**. The **User** may carry out an alternative range of tests if this is agreed with **NGET**. **NGET** may agree a reduced set of tests where there is a relevant **Manufacturers Data & Performance Report** as detailed in CP.10.



- CP.7.2.4 In the case of **Offshore Power Park Modules** which do not contribute to **Offshore Transmission Licensee Reactive Power** capability as described in CC.6.3.2(e)(i) or CC.6.3.2(e)(ii) or Voltage Control as described in CC.6.3.8(b)(i) the tests outlined in CP.7.2.2 (a) and CP.7.2.2 (b) are not required. However, the offshore reactive power transfer tests outlined in OC5.A.2.8 shall be completed in their place.
- CP.7.2.5 Following completion of each of the tests specified in this CP.7.2, **NGET** will notify the **Generator** or **DC Converter Station** owner whether, in the opinion of **NGET**, the results demonstrate compliance with the relevant Grid Code conditions.
- CP.7.2.6 The **Generator** or **DC Converter Station** owner is responsible for carrying out the tests and retains the responsibility for safety and personnel during the test.
- CP.7.3 Items for submission prior to issue of the **Final Operational Notification**
- CP.7.3.1 Prior to the issue of a **Final Operational Notification** the **Generator** or **DC Converter Station** owner must submit to **NGET** to **NGET's** satisfaction:
- (a) updated **Planning Code** data (both **Standard Planning Data** and **Detailed Planning Data**), with validated actual values and updated estimates for the future including **Forecast Data** items such as **Demand**;
  - (b) any items required by CP.5.2 and CP.6.3, updated by the **User** as necessary;
  - (c) evidence to **NGET's** satisfaction that demonstrates that the controller models and/or parameters (as required under PC.A.5.3.2(c) option 2, PC.A.5.3.2(d) option 2, PC.A.5.4.2, and/or PC.A.5.4.3.2) supplied to **NGET** provide a reasonable representation of the behaviour of the **User's Plant and Apparatus** and OTSUA if applicable;
  - (d) results from the tests required in accordance with CP.7.2 carried out by the **Generator** to demonstrate compliance with relevant Grid Code requirements including the tests witnessed by **NGET**; and
  - (e) the final **Compliance Statement** and a **User Self Certification of Compliance** signed by the **User** and a statement of any requirements that the **Generator** or **DC Converter Station** owner has identified that have not been met together with a copy of the derogation in respect of the same from the **Authority**.
- CP.7.3.2 The items in CP.7.3 should be submitted by the **Generator** (including in respect of any OTSUA if applicable) or **DC Converter Station** owner using the **User Data File Structure**.
- CP.7.4 If the requirements of CP.7.2 and CP.7.3 have been successfully met, **NGET** will notify the **Generator** or **DC Converter Station** owner that compliance with the relevant Grid Code provisions has been demonstrated for the **Generating Unit(s), CCGT Module(s), Power Park Module(s), OTSUA (if applicable)** or **DC Converter(s)** as applicable through the issue of a **Final Operational Notification**. In respect of a **Embedded Power Station** or **Embedded DC Converter Station** other than a **Embedded Medium Power Stations** not subject to a **Bilateral Agreement** and **Embedded DC Converter Stations** not subject to a **Bilateral Agreement**, **NGET** will notify the **Network Operator** that a **Final Operational Notification** has been issued.

CP.7.5 If a **Final Operational Notification** can not be issued because the requirements of CP.7.2 and CP.7.3 have not been successfully met prior to the expiry of an **Interim Operational Notification** then the **Generator** or **DC Converter Station** owner (where licensed in respect of its activities) and/or **NGET** shall apply to the **Authority** for a derogation. The provisions of CP.9 shall then apply.

CP.8 LIMITED OPERATIONAL NOTIFICATION

CP.8.1 Following the issue of a **Final Operational Notification** if:

- (i) the **Generator** or **DC Converter Station** owner becomes aware, that its **Plant** and/or **Apparatus**' (including OTSUA if applicable) capability to meet any provisions of the Grid Code, or where applicable the **Bilateral Agreement** is not fully available then the **Generator** or **DC Converter Station** owner shall follow the process in CP.8.2 to CP.8.11; or,
- (ii) a **Network Operator** becomes aware, that the capability of **Plant** and/or **Apparatus**' belonging to a **Embedded Power Station** or **Embedded DC Converter Station** (other than a **Embedded Medium Power Stations** not subject to a **Bilateral Agreement** and **Embedded DC Converter Stations** not subject to a **Bilateral Agreement**) is failing to meet any provisions of the Grid Code, or where applicable the **Bilateral Agreement** then the **Network Operator** shall inform **NGET** and **NGET** shall inform the **Generator** or **DC Converter Station** owner and then follow the process in CP.8.2 to CP.8.11; or,
- (iii) **NGET** becomes aware through monitoring as described in OC5.4, that a **Generator** or **DC Converter Station** owner **Plant** and/or **Apparatus**' (including OTSUA if applicable) capability to meet any provisions of the Grid Code, or where applicable the **Bilateral Agreement** is not fully available then **NGET** shall inform the other party. Where **NGET** and the **Generator** or **DC Converter Station** owner cannot agree from the monitoring as described in OC5.4 whether the **Plant** and/or **Apparatus** (including OTSUA if applicable) is fully available and/or is compliant with the requirements of the Grid Code and where applicable the **Bilateral Agreement**, the parties shall first apply the process in OC5.5.1, before applying the process defined in CP.8 (**LON**) if applicable. Where the testing instructed in accordance with OC.5.5.1 indicates that the **Plant** and/or **Apparatus** (including OTSUA if applicable) is not fully available and/or is not compliant with the requirements of the Grid Code and/or the **Bilateral Agreement**, or if the parties so agree, the process in CP.8.2 to CP.8.11 shall be followed.

CP.8.2 Immediately upon a **Generator** or **DC Converter Station** owner becoming aware that its **Generating Unit**, **CCGT Module**, **Power Park Module**, OTSUA (if applicable) or **DC Converter Station** as applicable may be unable to comply with certain provisions of the Grid Code or (where applicable) the **Bilateral Agreement**, the **Generator** or **DC Converter Station** owner shall notify **NGET** in writing. Additional details of any operating restrictions or changes in applicable data arising from the potential non-compliance and an indication of the date from when the restrictions will be removed and full compliance demonstrated shall be provided as soon as reasonably practical.

CP.8.3 If the nature of any unavailability and/or potential non-compliance described in CP.8.1 causes or can reasonably be expected to cause a material adverse effect on the business or condition of **NGET** or other **Users** or the **National Electricity Transmission System** or any **User Systems** then **NGET** may, notwithstanding the provisions of this CP.8 follow the provisions of Paragraph 5.4 of the **CUSC**.

- CP.8.4 Except where the provisions of CP.8.3 apply, where the restriction notified in CP.8.2 is not resolved in 28 days then the **Generator** or **DC Converter Station** owner with input from and discussion of conclusions with **NGET**, and the **Network Operator** where the **Generating Unit**, **CCGT Module**, **Power Park Module** or **Power Station** as applicable is **Embedded**, shall undertake an investigation to attempt to determine the causes of and solution to the non-compliance. Such investigation shall continue for no longer than 56 days. During such investigation the **Generator** or **DC Converter Station** owner shall provide to **NGET** the relevant data which has changed due to the restriction in respect of CP.7.3.1 as notified to the **Generator** or **DC Converter Station** owner by **NGET** as being required to be provided.
- CP.8.5 Issue and Effect of LON
- CP.8.5.1 Following the issue of a **Final Operational Notification**, **NGET** will issue to the **Generator** or **DC Converter Station** owner a **Limited Operational Notification** if:
- (a) by the end of the 56 day period referred to at CP.8.4, the investigation has not resolved the non-compliance to **NGET's** satisfaction; or
  - (b) **NGET** is notified by a **Generator** or **DC Converter Station** owner of a **Modification** to its **Plant** and **Apparatus** (including OTSUA if applicable); or
  - (c) **NGET** receives a submission of data, or a statement from a **Generator** or **DC Converter Station** owner indicating a change in **Plant** or **Apparatus** (including OTSUA if applicable) or settings (including but not limited to governor and excitation control systems) that may in **NGET's** reasonable opinion, acting in accordance with **Good Industry Practice** be expected to result in a material change of performance.
- In the case of an **Embedded Generator** or **Embedded DC Converter Station** owner, **NGET** will issue a copy of the **Limited Operational Notification** to the **Network Operator**.
- CP.8.5.2 The **Limited Operational Notification** will be time limited to expire no later than 12 months from the start of the non-compliance or restriction or from reconnection following a change. **NGET** may agree a longer duration in the case of a **Limited Operational Notification** following a **Modification** or whilst the **Authority** is considering the application for a derogation in accordance with CP.9.1.
- CP.8.5.3 The **Limited Operational Notification** will notify the **Generator** or **DC Converter Station** owner of any restrictions on the operation of the **Generating Unit(s)**, **CCGT Module(s)**, **Power Park Module(s)**, OTSUA (if applicable) or **DC Converter(s)** and will specify the **Unresolved Issues**. The **Generator** or **DC Converter Station** owner must operate in accordance with any notified restrictions and must resolve the **Unresolved Issues**.
- CP.8.5.4 When a **User** and **NGET** are acting/operating in accordance with the provisions of a **Limited Operational Notification**, whilst it is in force, the relevant provisions of the Grid Code to which that **Limited Operational Notification** relates will not apply to the **User** or **NGET** to the extent and for the period set out in the **Limited Operational Notification**.
- CP.8.5.5 The **Unresolved Issues** included in a **Limited Operational Notification** will show the extent that the provisions of CP.7.2 (testing) and CP.7.3 (final data submission) shall apply. In respect of selecting the extent of any tests which may in **NGET's** view reasonably be needed to demonstrate the restored capability and in agreeing the time period in which the tests will be scheduled, **NGET** shall, where reasonably practicable, take account of the **Generator** or **DC Converter Station** owner's input to contain its costs associated with the testing.

- CP.8.5.6 In the case of a change or **Modification** the **Limited Operational Notification** may specify that the affected **Plant** and/or **Apparatus** (including OTSUA if applicable) or associated **Generating Unit(s)** or **Power Park Unit(s)** must not be **Synchronised** until all of the following items, that in **NGET's** reasonable opinion are relevant, have been submitted to **NGET** to **NGET's** satisfaction:
- (a) updated **Planning Code** data (both **Standard Planning Data** and **Detailed Planning Data**);
  - (b) details of any relevant special **Power Station, Generating Unit(s), Power Park Module(s), OTSUA (if applicable)** or **DC Converter Station(s)** protection as applicable. This may include **Pole Slipping** protection and islanding protection schemes; and
  - (c) simulation study provisions of Appendix CP.A.3 and the results demonstrating compliance with Grid Code requirements relevant to the change or **Modification** as agreed by **NGET**; and
  - (d) a detailed schedule of the tests and the procedures for the tests required to be carried out by the **Generator** or **DC Converter Station** to demonstrate compliance with relevant Grid Code requirements as agreed by **NGET**. The schedule of tests shall be consistent with Appendix OC5.A.2 or Appendix OC5.A.3 as appropriate; and
  - (e) an interim **Compliance Statement** and a **User Self Certification of Compliance** completed by the **User** (including any **Unresolved Issues**) against the relevant Grid Code requirements including details of any requirements that the **Generator** or **DC Converter Station** owner has identified that will not or may not be met or demonstrated; and
  - (f) any other items specified in the **LON**.
- CP.8.5.7 The items referred to in CP.8.5.6 shall be submitted by the **Generator** (including in respect of any OTSUA if applicable) or **DC Converter Station** owner using the **User Data File Structure**.
- CP.8.5.8 In the case of **Synchronous Generating Unit(s)** only, the **Unresolved Issues** of the **LON** may require that the **Generator** must complete the following tests to **NGET's** satisfaction to demonstrate compliance with the relevant provisions of the **CCs** prior to the **Generating Unit** being **Synchronised** to the **Total System**:
- (a) those tests required to establish the open and short circuit saturation characteristics of the **Generating Unit** (as detailed in Appendix OC5.A.2.3) to enable assessment of the short circuit ratio in accordance with CC.6.3.2. Such tests may be carried out at a location other than the **Power Station** site; and
  - (b) open circuit step response tests (as detailed in Appendix OC5.A.2.2) to demonstrate compliance with CC.A.6.2.4.1.
- CP.8.6 In the case of a change or **Modification**, not less than 28 days, or such shorter period as may be acceptable in **NGET's** reasonable opinion, prior to the **Generator** or **DC Converter Station** owner wishing to **Synchronise** its **Plant** and **Apparatus** (including OTSUA if applicable) for the first time following the change or **Modification**, the **Generator** or **DC Converter Station** owner will:
- (i) submit a **Notification of User's Intention to Synchronise**; and
  - (ii) submit to **NGET** the items referred to at CP.8.5.6.

- CP.8.7 Other than **Unresolved Issues** that are subject to tests to be witnessed by **NGET**, the **Generator** or **DC Converter Station** owner must resolve any **Unresolved Issues** prior to the commencement of the tests, unless **NGET** agrees to a later resolution. The **Generator** or **DC Converter Station** owner must liaise with **NGET** in respect of such resolution. The tests that may be witnessed by **NGET** are specified in CP.7.2.2.
- CP.8.8 Not less than 28 days, or such shorter period as may be acceptable in **NGET's** reasonable opinion, prior to the **Generator** or **DC Converter Station** owner wishing to commence tests listed as **Unresolved Issues** to be witnessed by **NGET**, the **Generator** or **DC Converter Station** owner will notify **NGET** that the **Generating Unit(s)**, **CCGT Module(s)**, **Power Park Module(s)**, **OTSUA (if applicable)** or **DC Converter(s)** as applicable is ready to commence such tests.
- CP.8.9 The items referred to at CP.7.3 and listed as **Unresolved Issues** shall be submitted by the **Generator** or the **DC Converter Station** owner after successful completion of the tests.
- CP.8.10 Where the **Unresolved Issues** have been resolved a **Final Operational Notification** will be issued to the **User**.
- CP.8.11 If a **Final Operational Notification** has not been issued by **NGET** within the 12 month period referred to at CP.8.5.2 (or where agreed following a **Modification** by the expiry time of the **LON**) then the **Generator** or **DC Converter Station** owner (where licensed in respect of its activities) and **NGET** shall apply to the **Authority** for a derogation.
- CP.9 PROCESSES RELATING TO DEROGATIONS
- CP.9.1 Whilst the **Authority** is considering the application for a derogation, the **Interim Operational Notification** or **Limited Operational Notification** will be extended to remain in force until the **Authority** has notified **NGET** and the **Generator** or **DC Converter Station** owner of its decision. Where the **Generator** or **DC Converter Station** owner is not licensed **NGET** may propose any necessary changes to the **Bilateral Agreement** with such unlicensed **Generator** or **DC Converter Station** owner.
- CP.9.2 If the **Authority**:
- (a) grants a derogation in respect of the **Plant** and/or **Apparatus**, then **NGET** shall issue **Final Operational Notification** once all other **Unresolved Issues** are resolved; or
  - (b) decides a derogation is not required in respect of the **Plant** and/or **Apparatus** then **NGET** will reconsider the relevant **Unresolved Issues** and may issue a **Final Operational Notification** once all other **Unresolved Issues** are resolved; or
  - (c) decides not to grant any derogation in respect of the **Plant** and/or **Apparatus**, then there will be no **Operational Notification** in place and **NGET** and the **User** shall consider its rights pursuant to the **CUSC**.
- CP.9.3 Where an **Interim Operational Notification** or **Limited Operational Notification** is so conditional upon a derogation and such derogation includes any conditions (including any time limit to such derogation) the **Generator** or **DC Converter Station** owner will progress the resolution of any **Unresolved Issues** and / or progress and / or comply with any conditions upon such derogation and the provisions of CP.6.9 to CP.7.4 shall apply and shall be followed.
- CP.10 MANUFACTURER'S DATA & PERFORMANCE REPORT

- CP.10.1.1 Data and performance characteristics in respect of certain Grid Code requirements may be registered with **NET** by **Power Park Unit** manufacturers in respect of specific models of **Power Park Units** by submitting information in the form of a **Manufacturer's Data and Performance Report** to **NET**.
- CP.10.1.2 A **Generator** planning to construct a new **Power Station** containing the appropriate version of **Power Park Units** in respect of which a **Manufacturer's Data & Performance Report** has been submitted to **NET** may reference the **Manufacturer's Data & Performance Report** in its submissions to **NET**. Any **Generator** considering referring to a **Manufacturer's Data & Performance Report** for any aspect of its **Plant** and **Apparatus** may contact **NET** to discuss the suitability of the relevant **Manufacturer's Data & Performance Report** to its project to determine if, and to what extent, the data included in the **Manufacturer's Data & Performance Report** contributes towards demonstrating compliance with those aspects of the Grid Code applicable to the **Generator**. **NET** will inform the **Generator** if the reference to the **Manufacturer's Data & Performance Report** is not appropriate or not sufficient for its project.
- CP.10.1.3 The process to be followed by **Power Park Unit** manufacturers submitting a **Manufacturer's Data & Performance Report** is agreed by **NET**. CP.10.2 indicates the specific Grid Code requirement areas in respect of which a **Manufacturer's Data & Performance Report** may be submitted.
- CP.10.1.4 **NET** will maintain and publish a register of those **Manufacturer's Data & Performance Reports** which **NET** has received and accepted as being an accurate representation of the performance of the relevant **Plant** and / or **Apparatus**. Such register will identify the manufacturer, the model(s) of **Power Park Unit(s)** to which the report applies and the provisions of the Grid Code in respect of which the report contributes towards the demonstration of compliance. The inclusion of any report in the register does not in any way confirm that any **Power Park Modules** which utilise any **Power Park Unit(s)** covered by a report is or will be compliant with the Grid Code.
- CP.10.2 A **Manufacturer's Data & Performance Report** in respect of **Power Park Units** may cover one (or part of one) or more of the following provisions of the Grid Code:
- (a) Fault Ride Through capability CC.6.3.15
  - (b) **Power Park Module** mathematical model PC.A.5.4.2
- CP.10.3 Reference to a **Manufacturer's Data & Performance Report** in a **User's** submissions does not by itself constitute compliance with the Grid Code.
- CP.10.4 A **Generator** referencing a **Manufacturer's Data & Performance Report** should insert the relevant **Manufacturer's Data & Performance Report** reference in the appropriate place in the **DRC** data submission and / or in the **User Data File Structure**. **NET** will consider the suitability of a **Manufacturer's Data & Performance Report**:
- (a) in place of **DRC** data submissions a mathematical model suitable for representation of the entire **Power Park Module** as per CP.A.3.4.4. For the avoidance of doubt only the relevant sections as specified in PC.A.2.5.5.7 apply. Site specific parameters will still need to be submitted by the **Generator**.
  - (b) in place of Fault simulation studies as follows;  
**NET** will not require Fault Ride Through simulation studies to be conducted as per CP.A.3.5.1 and qualified in CP.A.3.5.2 provided that;

- (i) Adequate and relevant **Power Park Unit** data is included in respect of Fault Ride Through testing covered in CP.A.14.7.1 in the relevant **Manufacturer's Data & Performance Report** , and
  - (ii) For each type and duration of fault as detailed in CP.A.3.5.1, the expected minimum retained voltage is greater than the corresponding minimum voltage achieved and successfully ridden through in the fault ride through tests covered by the **Manufacturer's Data & Performance Report**.
- (c) to reduce the scope of compliance site tests as follows;
- (i) Where there is a **Manufacturer's Data & Performance Report** in respect of a **Power Park Unit** which covers Fault Ride Through, **NGET** may agree that no Fault Ride Through testing is required.

CP.10.5 It is the responsibility of the **User** to ensure that the correct reference for the **Manufacturer's Data & Performance Report** is used and the **User** by using that reference accepts responsibility for the accuracy of the information. The **User** shall ensure that the manufacturer has kept **NGET** informed of any relevant variations in plant specification since the submission of the relevant **Manufacturer's Data & Performance Report** which could impact on the validity of the information.

CP.10.6 **NGET** may contact the **Power Park Unit** manufacturer directly to verify the relevance of the use of such **Manufacturer's Data & Performance Report**. If **NGET** believe the use some or all of such **Manufacturer's Data & Performance Report** information is incorrect or the referenced data is inappropriate then the reference to the **Manufacturer's Data & Performance Report** may be declared invalid by **NGET**. Where, and to the extent possible, the data included in the **Manufacturer's Data & Performance Report** is appropriate, the compliance assessment process will be continued using the data included in the **Manufacturer's Data & Performance Report**.

# APPENDIX 1 - ILLUSTRATIVE PROCESS DIAGRAMS

## CP.A.1.1 Illustrative Compliance Process for Energisation of a User

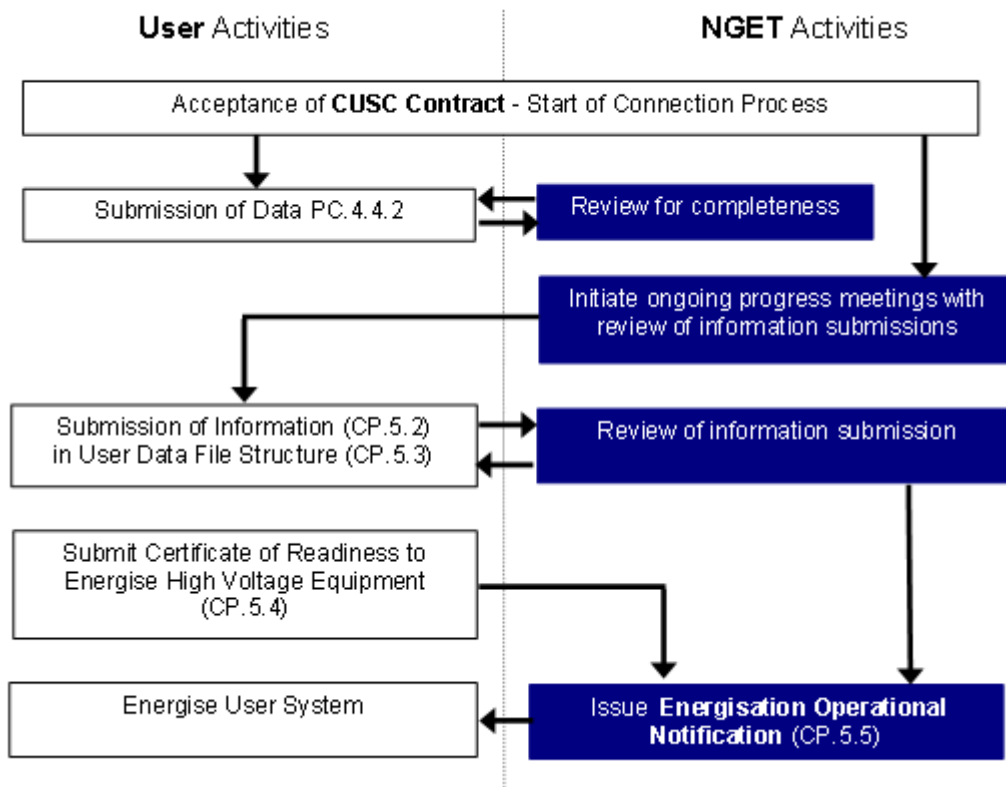

The process illustrated in CP.A.1.1 applies to all **Users** energising passive network **Plant** and **Apparatus** including **Distribution Network Operators**, **Non-embedded Customers**, **Generators** and **DC Converter Station** owners. This process is a subset of the full process for **Generators** and **DC Converter Station** owners shown in CP.A.1.2. This diagram illustrates the process in the **CP** and includes references in brackets to specific Grid Code clauses.



CP.A.1.2 Illustrative Compliance Process for New Power Stations/DC Converter Stations

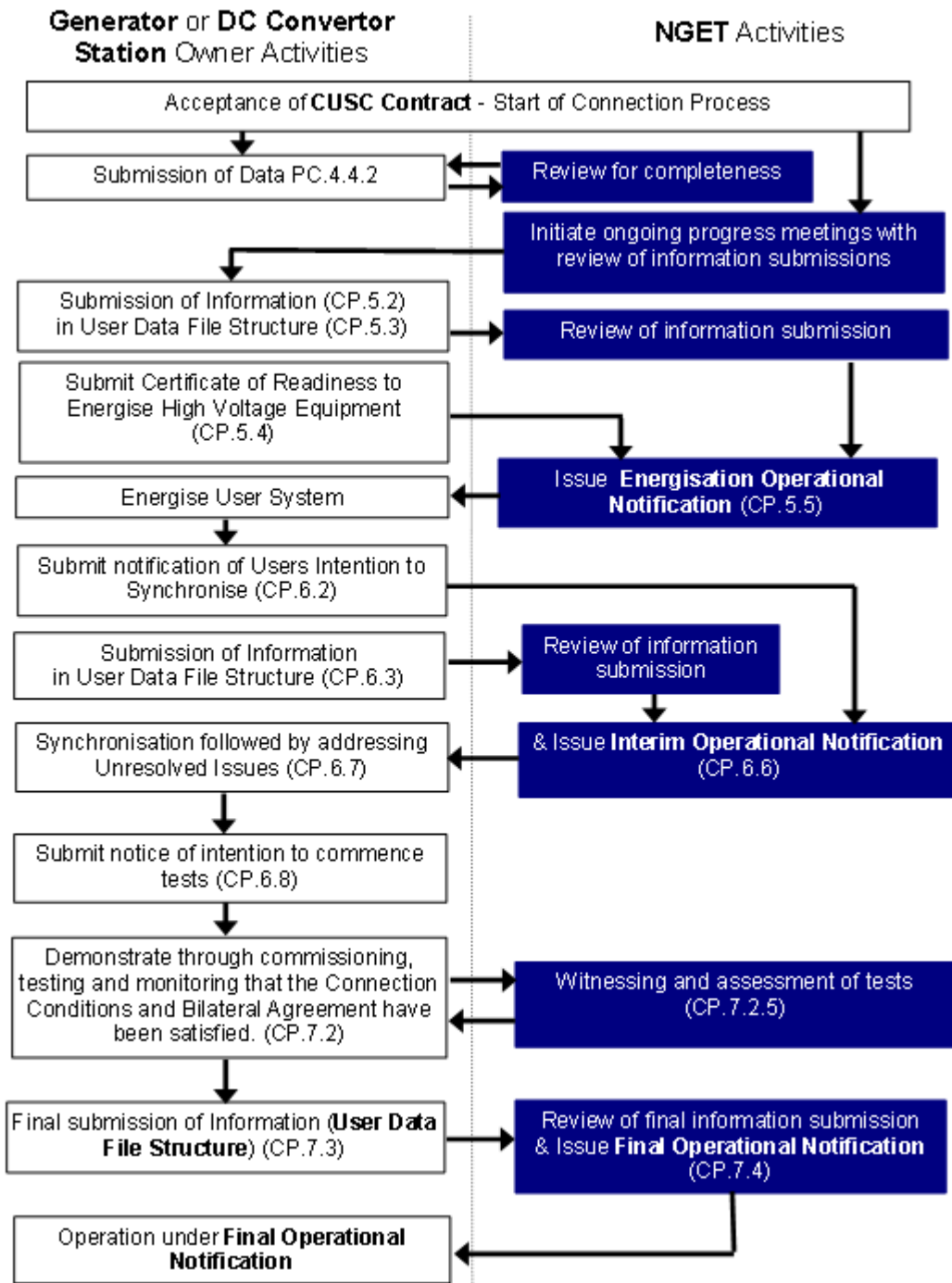

This diagram illustrates the process in the CP and includes references in brackets to specific Grid Code clauses. For the avoidance of doubt this process does not apply to **Embedded Medium Power Stations** not subject to a **Bilateral Agreement** and **Embedded DC Converter Stations** not subject to a **Bilateral Agreement**.

CP.A.1.3 Illustrative Compliance Process for New Offshore Power Stations and OTSUA

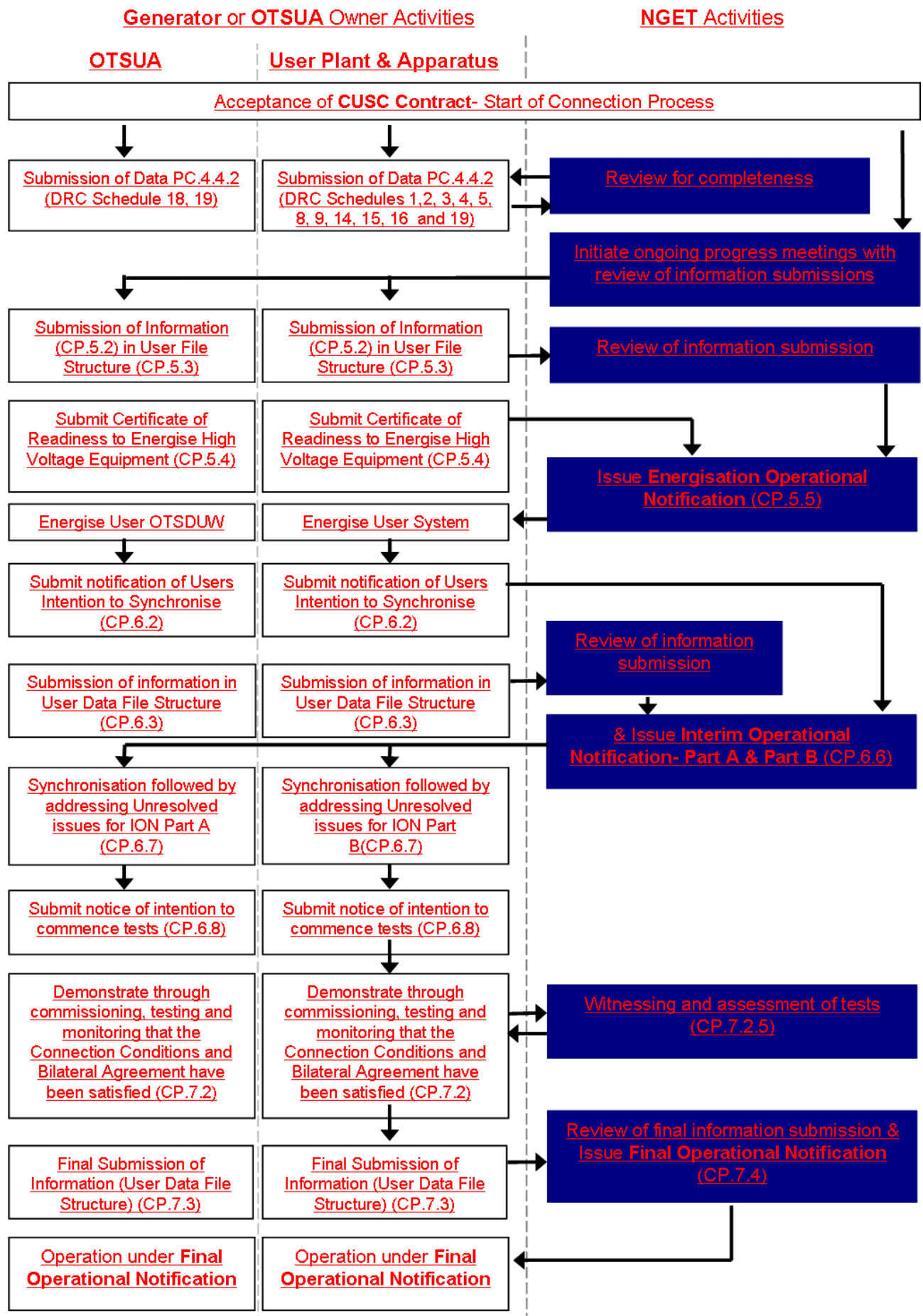

This diagram illustrates the process in the CP and includes references in brackets to specific Grid Code clauses.

CP.A.4.3 1.4 Illustrative Compliance Process for Ongoing Compliance

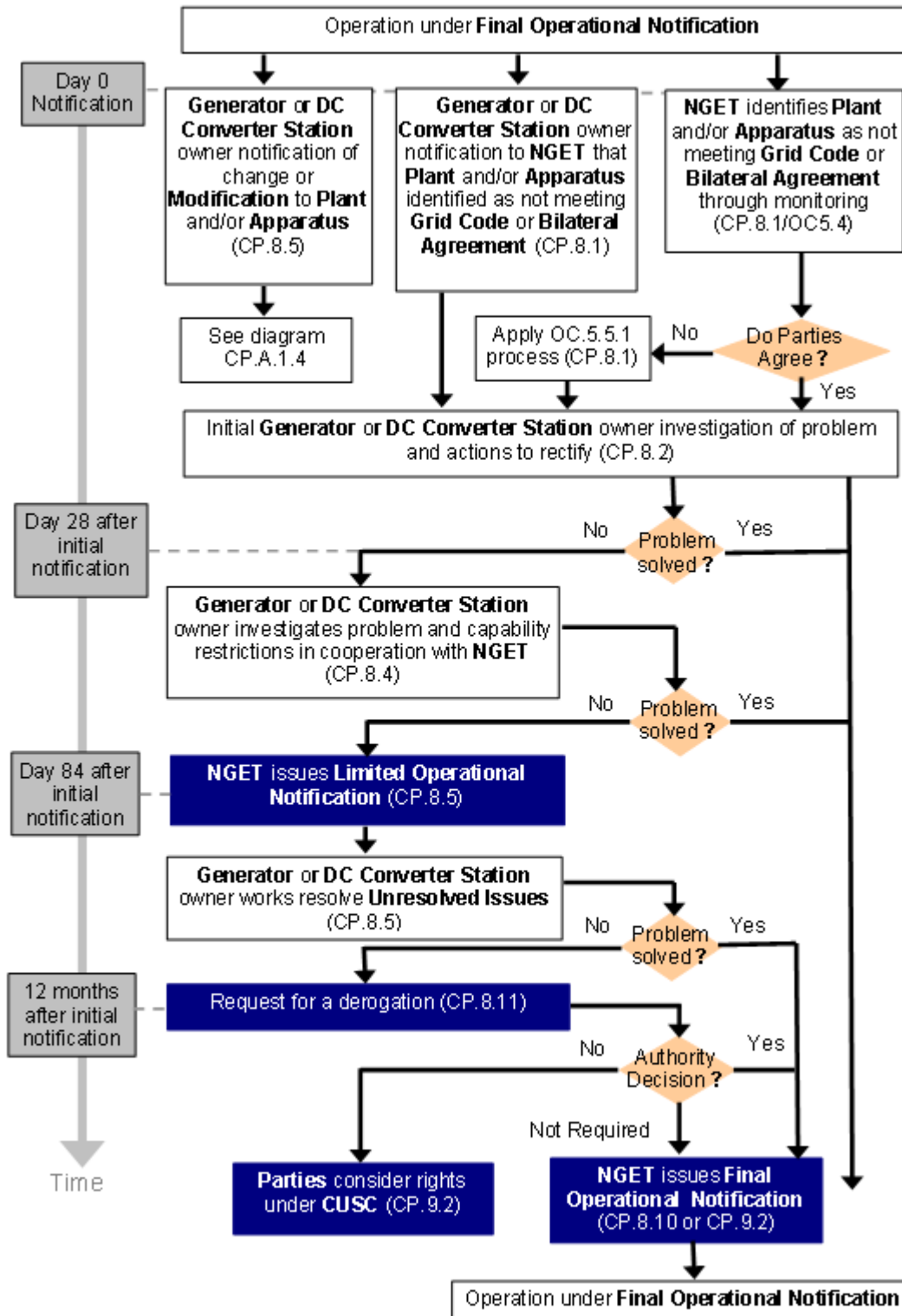

This diagram illustrates the process in the CP and includes references in brackets to specific Grid Code clauses. For the avoidance of doubt this process does not apply to **Embedded Medium Power Stations** not subject to a **Bilateral Agreement** and **Embedded DC Converter Stations** not subject to a **Bilateral Agreement**.

CP.A.4.41.5 Illustrative Compliance Process for Modification or change

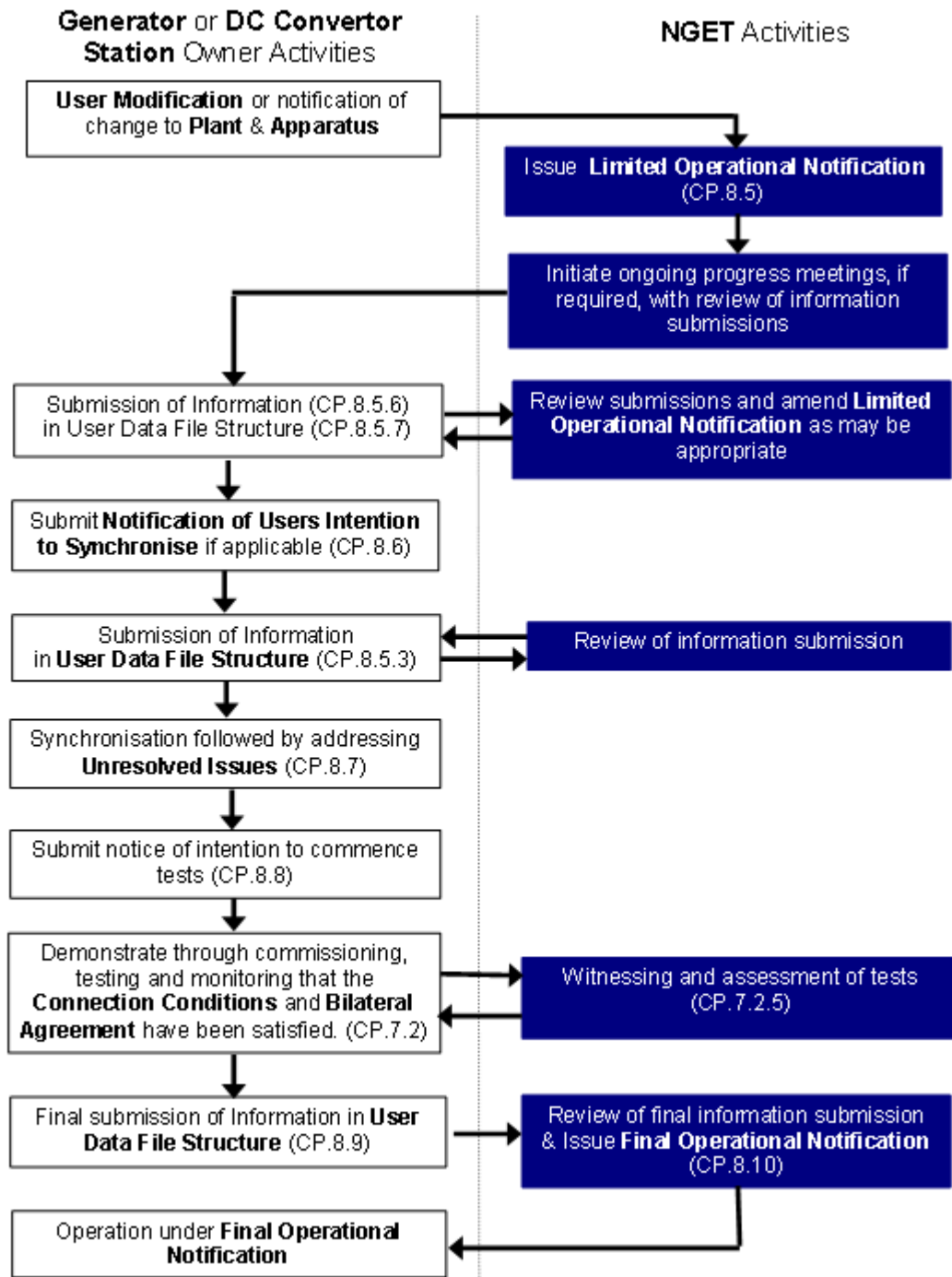

This diagram illustrates the process in the **CP** and includes references in brackets to specific Grid Code clauses. For the avoidance of doubt this process does not apply to **Embedded Medium Power Stations** not subject to a **Bilateral Agreement** and **Embedded DC Converter Stations** not subject to a **Bilateral Agreement**.

## APPENDIX 2 - USER SELF CERTIFICATION OF COMPLIANCE

### USER SELF CERTIFICATION OF COMPLIANCE (Interim/Final)

|   |  |
|---|--|
| <b>Power Station/ DC Converter Station:</b> | [Name of Connection Site/site of connection] |
| <b><u>OTSUA</u></b>                         | <b><u>[Name of Interface Site]</u></b>       |
| <b>User:</b>                                | [Full User name]                             |
| <b>Registered Capacity (MW) of Plant:</b>   |  |

This **User Self Certification of Compliance** records the compliance by the **User** in respect of [NAME] **Power Station/DC Converter Station** [and, in the case of OTSDUW Arrangements, OTSUA] with the Grid Code and the requirements of the **Bilateral Agreement** and **Construction Agreement** dated [ ] with reference number [ ]. It is completed by the **Power Station/DC Converter Station** owner in the case of **Plant** and/or **Apparatus** (including OTSUA) connected to the **National Electricity Transmission System** and for **Embedded Plant**.

We have recorded our compliance against each requirement of the Grid Code which applies to the **Power Station/DC Converter Station/OTSUA**, together with references to supporting evidence and a commentary where this is appropriate, and have provided this to **NGET**. A copy of the **Compliance Statement** is attached.

Supporting evidence, in the form of simulation results, test results, manufacturer's data and other documentation, is attached in the **User Data File Structure**.

The **User** hereby certifies that, to the best of its knowledge and acting in accordance with **Good Industry Practice**, [the Power Station is compliant with the Grid Code and the Bilateral Agreement] [the OTSUA is compliant with the Grid Code and the Construction Agreement] in all aspects [with the following **Unresolved Issues\***] [with the following derogation(s)\*\*]:

| Connection Condition | Requirement | Ref: | Issue |
|----------------------|-------------|------|-------|
|                      |             |      |       |
|                      |             |      |       |
|                      |             |      |       |
|                      |             |      |       |
|                      |             |      |       |

|                                 |            |  |
|---------------------------------|------------|--|
| <b>Compliance certified by:</b> | Name:      | Title:<br>[PERSON DESIGNATION]<br>Of<br>[USER DETAILS] |
|                                 | [PERSON]   |  |
|                                 | Signature: |  |
|                                 | [PERSON]   |  |
| Date:                           |            |  |

\* Include for Interim User Self Certification of Compliance ahead of Interim Operational Notification

\*\* Include for final User Self Certification of Compliance ahead of Final Operational Notification where derogation(s) have been granted. If no derogation(s) required delete wording and Table.

## APPENDIX 3 - SIMULATION STUDIES

- CP.A.3.1.1 This Appendix sets out the simulation studies required to be submitted to **NGET** to demonstrate compliance with the Connection Conditions unless otherwise agreed with **NGET**. This Appendix should be read in conjunction with CP.6 with regard to the submission of the reports to **NGET**. Where there is any inconsistency in the technical requirements in respect of which compliance is being demonstrated by simulation in this Appendix and CC.6.3 and the **Bilateral Agreement**, the provisions of the **Bilateral Agreement** and CC.6.3 prevail. The studies specified in this Appendix will normally be sufficient to demonstrate compliance. However **NGET** may agree an alternative set of studies proposed by the **Generator** or **DC Converter Station** owner provided **NGET** deem the alternative set of studies sufficient to demonstrate compliance with the Grid Code and the **Bilateral Agreement**.
- CP.A.3.1.2 The **Generator** or **DC Converter Station** owner shall submit simulation studies in the form of a report to demonstrate compliance. In all cases the simulation studies must utilise models applicable to the **Generating Unit**, **DC Converter** or **Power Park Module** with proposed or actual parameter settings. Reports should be submitted in English with all diagrams and graphs plotted clearly with legible axes and scaling provided to ensure any variations in plotted values is clear.
- CP.A.3.1.3 In the case of an **Offshore Power Station** where **OTSDUW Arrangements** apply simulation studies by the **Generator** should include the action of any relevant **OTSUA** where applicable to demonstrate compliance with the Grid Code and the **Bilateral Agreement** at the **Interface Point**.
- CP.A.3.2 Power System Stabiliser Tuning
- CP.A.3.2.1 In the case of a **Synchronous Generating Unit** the **Power System Stabiliser** tuning simulation study report required by CC.A.6.2.5.6 or required by the **Bilateral Agreement** shall contain:
- (i) the **Excitation System** model including the **Power System Stabiliser** with settings as required under the **Planning Code** (PC.A.5.3.2(c))
  - (ii) on load time series dynamic simulation studies of the response of the **Excitation System** with and without the **Power System Stabiliser** to 2% and 10% steps in the reference voltage and a three phase short circuit fault applied to the higher voltage side of the **Generating Unit** transformer for 100ms. The simulation studies should be carried out with the **Generating Unit** operating at full **Active Power** and maximum leading **Reactive Power** import with the fault level at the **Supergrid HV** connection point at minimum or as otherwise agreed with **NGET**. The results should show **Generating Unit** field voltage, **Generating Unit** terminal voltage, **Power System Stabiliser** output, **Generating Unit Active Power** and **Generating Unit Reactive Power** output.
  - (iii) gain and phase Bode diagrams for the open loop frequency domain response of the **Generating Unit Excitation System** with and without the **Power System Stabiliser**. These should be in a suitable format to allow assessment of the phase contribution of the **Power System Stabiliser** and the gain and phase margin of the **Excitation System** with and without the **Power System Stabiliser** in service.
  - (iv) an eigenvalue plot to demonstrate that all modes remain stable when the **Power System Stabiliser** gain is increased by at least a factor of 3 from the designed operating value.

- (v) gain Bode diagram for the closed loop on load frequency domain response of the **Generating Unit Excitation System** with and without the **Power System Stabiliser**. The **Generating Unit** operating at full load and at unity power factor. These diagrams should be in a suitable format to allow comparison of the **Active Power** damping across the frequency range specified in CC.A.6.2.6.3 with and without the **Power System Stabiliser** in service.

CP.A.3.2.2 In the case of **Onshore Non-Synchronous Generating Units, Onshore DC Converters** and **Onshore Power Park Modules** and **OTSDUW Plant and Apparatus** at the **Interface Point** the **Power System Stabiliser** tuning simulation study report required by CC.A.7.2.4.1 or required by the **Bilateral Agreement** shall contain:

- (i) the **Voltage Control System** model including the **Power System Stabiliser** with settings as required under the **Planning Code** (PC.A.5.4) and **Bilateral Agreement**.
- (ii) on load time series dynamic simulation studies of the response of the **Voltage Control System** with and without the **Power System Stabiliser** to 2% and 10% steps in the reference voltage and a three phase short circuit fault applied to the **Grid Entry Point** or the **Interface Point** in the case of **OTSDUW Plant and Apparatus** for 100ms. The simulation studies should be carried out operating at full **Active Power** and maximum leading **Reactive Power** import condition with the fault level at the **Supergrid HV** connection point at minimum or as otherwise agreed with **NGET**. The results should show appropriate signals to demonstrate the expected damping performance of the **Power System Stabiliser**.
- (iii) any other simulation as specified in the **Bilateral Agreement** or agreed between the **Generator** or **DC Converter Owner** or **Offshore Transmission Licensee** and **NGET**.

CP.A.3.3 Reactive Capability across the Voltage Range

CP.A.3.3.1 The **Generator** or **DC Converter station** owner shall supply simulation studies to demonstrate the capability to meet CC.6.3.4 by submission of a report containing:

- (i) a load flow simulation study result to demonstrate the maximum lagging **Reactive Power** capability of the **Synchronous Generating Unit, DC Converter, OTSUA** or **Power Park Module** at **Rated MW** when the **Grid Entry Point** or **User System Entry Point** if **Embedded** or Interface Point (in case of OTSUA) voltage is at 105% of nominal.
- (ii) a load flow simulation study result to demonstrate the maximum leading **Reactive Power** capability of the **Synchronous Generating Unit, DC Converter, OTSUA** or **Power Park Module** at **Rated MW** when the **Grid Entry Point** or **User System Entry Point** ~~voltage~~ if **Embedded** or Interface Point (in case of OTSUA) voltage is at 95% of nominal.

CP.A.3.3.2 In the case of a **Synchronous Generating Unit** the terminal voltage in the simulation should be the nominal voltage for the machine.

CP.A.3.3.3 In the case of a **Power Park Module** where the load flow simulation studies show that the individual **Power Park Units** deviate from nominal voltage to meet the **Reactive Power** requirements then evidence must be provided from factory (e.g. in a **Manufacturer's Data & Performance Report**) or site testing that the **Power Park Unit** is capable of operating continuously at the operating points determined in the load flow simulation studies.

CP.A.3.4 Voltage Control and Reactive Power Stability

- CP.A.3.4.1 In the case of a power station containing **Power Park Modules** and/or OTSUA the **Generator** shall provide a report to demonstrate the dynamic capability and control stability of the **Power Park Module**. The report shall contain:
- (i) a dynamic time series simulation study result of a sufficiently large negative step in **System** voltage to cause a change in **Reactive Power** from zero to the maximum lagging value at **Rated MW**.
  - (ii) a dynamic time series simulation study result of a sufficiently large positive step in **System** voltage to cause a change in **Reactive Power** from zero to the maximum leading value at **Rated MW**.
  - (iii) a dynamic time series simulation study result to demonstrate control stability at the lagging **Reactive Power** limit by application of a -2% voltage step while operating within 5% of the lagging **Reactive Power** limit.
  - (iv) a dynamic time series simulation study result to demonstrate control stability at the leading **Reactive Power** limit by application of a +2% voltage step while operating within 5% of the leading **Reactive Power** limit.
- CP.A.3.4.2 All the above studies should be completed with a nominal network voltage for zero **Reactive Power** transfer at the **Grid Entry Point** or **User System Entry Point** if **Embedded** or, in the case of OTSUA, Interface Point unless stated otherwise and the fault level at the **HV** connection point at minimum as agreed with **NGET**.
- CP.A.3.4.3 **NGET** may permit relaxation from the requirements of CP.A.3.4.1(i) and (ii) for voltage control if the **Power Park Modules** are comprised of **Power Park Units** in respect of which the **User** has in its submissions to **NGET** referenced an appropriate **Manufacturer's Data & Performance Report** which is acceptable to **NGET** for voltage control.
- CP.A.3.4.4 In addition **NGET** may permit a further relaxation from the requirements of CP.A.3.4.1(iii) and (iv) if the **User** has in its submissions to **NGET** referenced an appropriate **Manufacturer's Data & Performance Report** for a **Power Park Module** mathematical model for voltage control acceptable to **NGET**.
- CP.A.3.5 Fault Ride Through
- CP.A.3.5.1 The **Generator**, (including where undertaking OTSDUW) or **DC Converter Station** owner shall supply time series simulation study results to demonstrate the capability of **Non-Synchronous Generating Units, DC Converters, and Power Park Modules** and OTSUA to meet CC.6.3.15 by submission of a report containing:
- (i) a time series simulation study of a 140ms solid three phase short circuit fault applied on the nearest point of the **National Electricity Transmission System** operating at **Supergrid** voltage to the **Non-Synchronous Generating Unit, DC Converter, or Power Park Module** or OTSUA.
  - (ii) time series simulation study of 140ms unbalanced short circuit faults applied on the nearest point of the **National Electricity Transmission System** operating at **Supergrid** voltage to the **Non-Synchronous Generating Unit, DC Converter, or Power Park Module** or OTSUA.  
The unbalanced faults to be simulated are:
    - 1. a phase to phase fault
    - 2. a two phase to earth fault
    - 3. a single phase to earth fault.



For a **Non-Synchronous Generating Unit, DC Converter or Power Park Module or OTSUA** the simulation study should be completed with the **Non-Synchronous Generating Unit, DC Converter or Power Park Module or OTSUA** operating at full **Active Power** and maximum leading **Reactive Power** import and the fault level at the **Supergrid HV** connection point at minimum or as otherwise agreed with **NGET**.

(iii) time series simulation studies of balanced **Supergrid** voltage dips applied on the nearest point of the **National Electricity Transmission System** operating at **Supergrid** voltage to the **Non-Synchronous Generating Unit, DC Converter or Power Park Module or OTSUA**. The simulation studies should include:

1. 30% retained voltage lasting 0.384 seconds
2. 50% retained voltage lasting 0.71 seconds
3. 80% retained voltage lasting 2.5 seconds
4. 85% retained voltage lasting 180 seconds.

For a **Non-Synchronous Generating Unit, DC Converter or Power Park Module or OTSUA** the simulation study should be completed with the **Non-Synchronous Generating Unit, DC Converter or Power Park Module or OTSUA** operating at full **Active Power** and zero **Reactive Power** output and the fault level at the **Supergrid HV** connection point at minimum or as otherwise agreed with **NGET**. Where the **Non-Synchronous Generating Unit, DC Converter or Power Park Module** is **Embedded** the minimum **Network Operator's System** impedance to the **Supergrid HV** connection point shall be used which may be calculated from the maximum fault level at the **User System Entry Point**.

For **DC Converters** the simulations should include the duration of each voltage dip 1 to 4 above for which the **DC Converter** will remain connected.

CP.A.3.5.2 In the case of **Power Park Modules** comprised of **Power Park Units** in respect of which the **User's** reference to a **Manufacturer's Data & Performance Report** has been accepted by **NGET** for Fault Ride Through, CP.A.3.5.1 will not apply provided:

(i) the **Generator or DC Converter Station** owner demonstrates by load flow simulation study result that the faults and voltage dips at either side of the **Power Park Unit** transformer corresponding to the required faults and voltage dips in CP.A.3.5.1 applied at the nearest point of the **National Electricity Transmission System** operating at **Supergrid** voltage are less than those included in the **Manufacturer's Data & Performance Report**,

or;

(ii) the same or greater percentage faults and voltage dips in CP.A.3.5.1 have been applied at either side of the **Power Park Unit** transformer in the **Manufacturer's Data & Performance Report**.

CP.A.3.5.3 In the case of an **Offshore Power Park Module or Offshore DC Converter** the studies may instead be completed at the **LV Side of the Offshore Platform**. For fault simulation studies described in CCA.8.5.1(i) and CCA.8.5.1(ii) a retained voltage of 15% or lower may be applied at the **LV Side of the Offshore Platform** on the faulted phases. For voltage dip simulation studies described in CP.A.3.5.1(iii) the same voltage levels and durations as normally applied at the **National Electricity Transmission System** operating at **Supergrid Voltage** will be applied at the **LV Side of the Offshore Platform**.

CP.A.3.6 Load Rejection

- CP.A.3.6.1 In respect of **Generating Units** or **DC Converters** or **Power Park Modules** with a **Completion Date** on or after 1 January 2012, the **Generator** or **DC Converter Station** owner shall demonstrate the speed control performance of the plant under a part load rejection condition as required by CC.6.3.7(c)(i), through simulation study. In respect of **Generating Units** or **DC Converters** or **Power Park Modules**, including those with a **Completion Date** before 1 January 2013, the load rejection capability while still supplying load must be stated in accordance with PC.A.5.3.2(f).
- CP.A.3.6.2 For **Power Park Modules** comprised of **Power Park Units** having a corresponding generically verified and validated model included in the **Manufacturer's Data & Performance Report** this study is not required if the correct **Manufacturer's Data & Performance Report** reference has been submitted in the appropriate location in the **Data Registration Code**.
- CP.A.3.6.3 The simulation study should comprise of a **Generating Unit, DC Converter** or **Power Park Module** connected to the total **System** with a local load shown as "X" in figure CP.A.3.6.1. The load "X" is in addition to any auxiliary load of the **Power Station** connected directly to the **Generating Unit, DC Converter** or **Power Park Module** and represents a small portion of the **System** to which the **Generating Unit, DC Converter** or **Power Park Module** is attached. The value of "X" should be the minimum for which the **Generating Unit, DC Converter** or **Power Park Module** can control the power island frequency to less than 52Hz. Where transient excursions above 52Hz occur the **Generator** or **DC Converter Owner** should ensure that the duration above 52Hz is less than any high frequency protection system applied to the **Generating Unit, DC Converter** or **Power Park Module**.
- CP.A.3.6.4 At the start of the simulation study the **Generating Unit, DC Converter** or **Power Park Module** will be operating maximum **Active Power** output. The **Generating Unit, DC Converter** or **Power Park Module** will then be islanded from the **Total System** but still supplying load "X" by the opening of a breaker, which is not the **Generating Unit, DC Converter** or **Power Park Module** connection circuit breaker (the governor should therefore, not receive any signals that the breaker has opened other than the reduction in load and subsequent increase in speed). A schematic arrangement of the simulation study is illustrated by Figure CP.A.3.6.1.

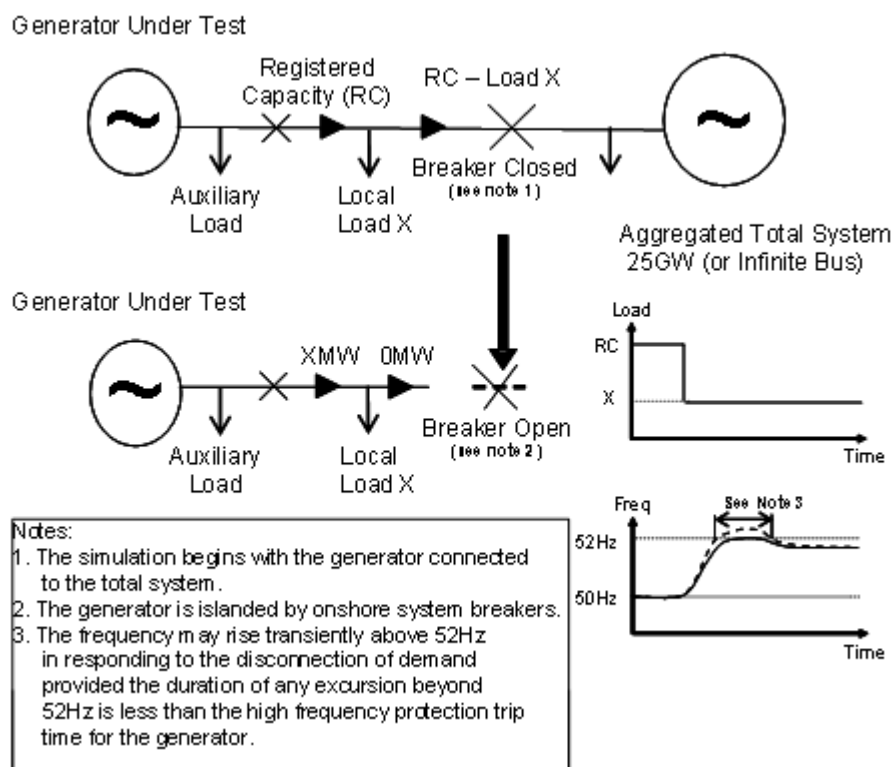

Figure CP.A.3.6.1 – Diagram of Load Rejection Study

- CP.A.3.6.5 Simulation study shall be performed for both control modes, **Frequency Sensitive Mode (FSM)** and **Limited Frequency Sensitive Mode (LFSM)**. The simulation study results should indicate **Active Power** and **Frequency** in the island system that includes the **Generating Unit, DC Converter or Power Park Module**.
- CP.A.3.6.6 To allow validation of the model used to simulate load rejection in accordance with CC.6.3.7(c)(i) as described a further simulation study is required to represent the largest positive **Frequency** injection step or fast ramp (BC1 and BC3 of Figure 2) that will be applied as a test as described in OC5.A.2.8 and OC5.A.3.6.
- CP.A.3.7 Voltage and Frequency Controller Model Verification and Validation
- CP.A.3.7.1 For **Generating Units, DC Converters or Power Park Modules** with a **Completion Date** after 1 January 2012 or subject to a **Modification** to a **Excitation System**, voltage control system, governor control system or **Frequency** control system after 1 January 2012 the **Generator or DC Converter Station** owner shall provide simulation studies to verify that the proposed controller models supplied to **NGET** under the **Planning Code** are fit for purpose. These simulation study results shall be provided in the timescales stated in the **Planning Code**. For **Power Park Modules** comprised of **Power Park Units** having a corresponding generically verified and validated model in a **Manufacturer's Data & Performance Report** **NGET** may permit the simulation studies detailed in CP.A.3.7.2, CP.A.3.7.4 and CP.A.3.7.5 to be replaced by submission of the correct **Manufacturer's Data & Performance Report** reference in the appropriate location in the **Data Registration Code**.
- CP.A.3.7.2 To demonstrate the **Frequency** control or governor/load controller/plant model the **Generator or DC Converter Station** owner shall submit a simulation study representing the response of the **Synchronous Generating Unit, DC Converter or Power Park Module** operating at 80% of **Registered Capacity**. The simulation study event shall be equivalent to:
- (i) a ramped reduction in the measured **System Frequency** of 0.5Hz in 10 seconds followed by
  - (ii) 20 seconds of steady state with the measured **System Frequency** depressed by 0.5Hz followed by
  - (iii) a ramped increase in measured **System Frequency** of 0.3Hz over 30 seconds followed by
  - (iv) 60 seconds of steady state with the measured **System Frequency** depressed by 0.2Hz as illustrated in Figure CP.A.3.7.2 below.

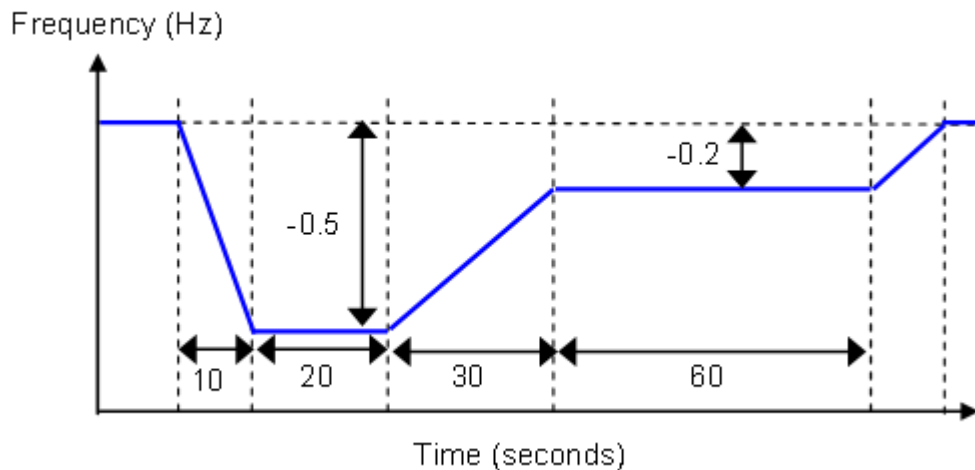

Figure CP.A.3.7.2

The simulation study shall show **Active Power** output (MW) and the equivalent of **Frequency** injected.

CP.A.3.7.3 To demonstrate the **Excitation System** model the **Generator** shall submit simulation studies representing the response of the **Synchronous Generating Unit** as follows:

- (i) operating open circuit at rated terminal voltage and subjected to a 2% step increase in terminal voltage reference.
- (ii) operating at **Rated MW**, nominal terminal voltage and unity power factor subjected to a 2% step increase in the voltage reference. Where a **Power System Stabiliser** is included within the **Excitation System** this shall be in service.

The simulation study shall show the terminal voltage, field voltage of the **Generating Unit**, **Active Power**, **Reactive Power** and **Power System Stabiliser** output signal as appropriate.

CP.A.3.7.4 To demonstrate the Voltage Controller model the **Generator** or **DC Converter Station** owner shall submit a simulation study representing the response of the **Non-Synchronous Generating Unit**, **DC Converter** or **Power Park Module** operating at **Rated MW** and unity power factor at the connection point to a 2% step increase in the voltage reference. The simulation study shall show the terminal voltage, **Active Power**, **Reactive Power** and **Power System Stabiliser** output signal as appropriate.

CP.A.3.7.5 To validate that the excitation and voltage control models submitted under the **Planning Code** are a reasonable representation of the dynamic behaviour of the **Synchronous Generating Unit**, **DC Converter Station** or **Power Park Module** as built, the **Generator** or **DC Converter Station** owner shall repeat the simulation studies outlined above but using the operating conditions of the equivalent tests. The simulation study results shall be displayed overlaid on the actual test results.

CP.A.3.7.7 For **Generating Units** or **DC Converters** with a **Completion Date** after 1 January 2012 or subject to a **Modification** to the governor system or **Frequency** control system after 1 January 2013 to validate that the governor/load controller/plant or **Frequency** control models submitted under the **Planning Code** is a reasonable representation of the dynamic behaviour of the **Synchronous Generating Unit** or **DC Converter Station** as built, the **Generator** or **DC Converter Station** owner shall repeat the simulation studies outlined above but using the operating conditions of the equivalent tests. The simulation study results shall be displayed overlaid on the actual test results.

- CP.A.3.8 Sub-synchronous Resonance Control and Power Oscillation Damping Control for DC Converters
- CP.A.3.8.1 To demonstrate the compliance of the sub-synchronous control function with CC.6.3.16(a) and the terms of the **Bilateral Agreement**, the **DC Converter Station** owner or Generator undertaking OTSDUW shall submit a simulation study report.
- CP.A.3.8.2 Where power oscillation damping control function is specified on a **DC Converter** the **DC Converter Station** owner or Generator undertaking OTSDUW shall submit a simulation study report to demonstrate the compliance with CC.6.3.16(b) and the terms of the **Bilateral Agreement**.
- CP.A.3.8.3 The simulation studies should utilise the **DC Converter** control system models including the settings as required under the **Planning Code** (PC.A.5.3.2). The network conditions for the above simulation studies should be discussed with **NGET** prior to commencing any simulation studies.

< END OF COMPLIANCE PROCESSES >

# OPERATING CODE NO. 5 (OC5)

## TESTING AND MONITORING

### CONTENTS

(This contents page does not form part of the Grid Code)

| <u>Paragraph No/Title</u>   | <u>Page Number</u> |
|---|--------------------|
| OC5.1 INTRODUCTION.....   | 2                  |
| OC5.2 OBJECTIVE .....   | 3                  |
| OC5.3 SCOPE.....  | 3                  |
| OC5.4 MONITORING.....   | 3                  |
| OC5.4.1 Parameters To Be Monitored .....  | 3                  |
| OC5.4.2 Procedure For Monitoring.....   | 3                  |
| OC5.5 PROCEDURE FOR TESTING.....  | 4                  |
| OC5.5.1 NGET Instruction For Testing .....  | 4                  |
| OC5.5.2 User Request For Testing .....  | 5                  |
| OC5.5.3 Conduct Of Test .....   | 5                  |
| OC5.5.4 Test And Monitoring Assessment .....  | 5                  |
| OC5.5.5 Test Failure / Re-test.....   | 8                  |
| OC5.5.6 Dispute Following Re-test .....   | 9                  |
| OC5.6 DISPUTE RESOLUTION .....  | 9                  |
| OC5.7 BLACK START TESTING .....   | 9                  |
| OC5.7.1 General.....  | 9                  |
| OC5.7.2 Procedure For A Black Start Test .....  | 10                 |
| OC5.8 PROCEDURES APPLYING TO EMBEDDED MEDIUM POWER STATION NOT SUBJECT<br>TO A BILATERAL AGREEMENT AND EMBEDDED DC CONVERTER STATIONS NOT SUBJECT<br>TO A BILATERAL AGREEMENT ..... | 11                 |
| APPENDIX 1 - ONSITE SIGNAL PROVISION FOR WITNESSING TESTS .....   | 13                 |
| APPENDIX 2 - COMPLIANCE TESTING OF SYNCHRONOUS PLANT .....  | 16                 |
| APPENDIX 3 - COMPLIANCE TESTING OF POWER PARK MODULES .....   | 26                 |
| APPENDIX 4 - COMPLIANCE TESTING FOR DC CONVERTERS AT A DC CONVERTER STATION.....  | 36                 |

INTRODUCTION

**Operating Code No. 5 ("OC5")** specifies the procedures to be followed by **NGET** in carrying out:

- (a) monitoring
  - (i) of **BM Units** against their expected input or output;
  - (ii) of compliance by **Users** with the **CC** and in the case of response to **Frequency, BC3**; and
  - (iii) of the provision by **Users** of **Ancillary Services** which they are required or have agreed to provide; and
- (b) the following tests (which are subject to **System** conditions prevailing on the day):
  - (i) tests on **Gensets, CCGT Modules, Power Park Modules, DC Converters, OTSUA (prior to the OTSUA Transfer Time)** and **Generating Units** (excluding **Power Park Units**) to test that they have the capability to comply with the **CC** and, in the case of response to **Frequency, BC3** and to provide the **Ancillary Services** that they are either required or have agreed to provide;
  - (ii) tests on **BM Units**, to ensure that the **BM Units** are available in accordance with their submitted **Export and Import Limits, QPNs, Joint BM Unit Data** and **Dynamic Parameters**.

The **OC5** tests include the **Black Start Test** procedure.

**OC5** also specifies in OC5.8 the procedures which apply to the monitoring and testing of **Embedded Medium Power Stations** not subject to a **Bilateral Agreement** and **Embedded DC Converter Stations** not subject to a **Bilateral Agreement**.

In respect of a **Cascade Hydro Scheme** the provisions of **OC5** shall be applied as follows:

- (a) in respect of the **BM Unit** for the **Cascade Hydro Scheme** the parameters referred to at OC5.4.1 (a) and (c) in respect of **Commercial Ancillary Services** will be monitored and tested;
- (b) in respect of each **Genset** forming part of the **Cascade Hydro Scheme** the parameters referred to at OC5.4.1 (a), (b) and (c) will be tested and monitored. In respect of OC5.4.1 (a) the performance of the **Gensets** will be tested and monitored against their expected input or output derived from the data submitted under BC1.4.2(a)(2). Where necessary to give effect to the requirements for **Cascade Hydro Schemes** in the following provisions of **OC5** the term **Genset** will be read and construed in the place of **BM Unit**.

In respect of **Embedded Exemptable Large Power Stations** the provisions of **OC5** shall be applied as follows:

- (a) where there is a **BM Unit** registered in the **BSC** in respect of **Generating Units** the provisions of **OC5** shall apply as written;
- (b) in all other cases, in respect of each **Generating Unit** the parameters referred to at OC5.4.1(a), (b) and (c) will be tested and monitored. In respect of OC5.4.1(a) the performance of the **Generating Unit** will be tested and monitored against their expected input or output derived from the data submitted under BC1.4.2(a)(2). Where necessary to give effect to the requirements for such **Embedded Exemptable Large Power Stations** in the provisions of **OC5** the term **Generating Unit** will be read and construed in place of **BM Unit**.

OC5.2

OBJECTIVE

The objectives of **OC5** are to establish:

- (a) that **Users** comply with the **CC** (including in the case of **OTSUA** prior to the **OTSUA Transfer Time**);
- (b) whether **BM Units** operate in accordance with their expected input or output derived from their **Final Physical Notification Data** and agreed **Bid-Offer Acceptances** issued under **BC2**;
- (c) whether each **BM Unit** is available as declared in accordance with its submitted **Export and Import Limits, QPN, Joint BM Unit Data** and **Dynamic Parameters**; and
- (d) whether **Generators, DC Converter Station** owners and **Suppliers** can provide those **Ancillary Services** which they are either required or have agreed to provide.

In certain limited circumstances as specified in this **OC5** the output of **CCGT Units** may be verified, namely the monitoring of the provision of **Ancillary Services** and the testing of **Reactive Power** and automatic **Frequency Sensitive Operation**.

OC5.3

SCOPE

**OC5** applies to **NGET** and to **Users**, which in **OC5** means:

- (a) **Generators** (including those undertaking **OTSDUW**);
- (b) **Network Operators**;
- (c) **Non-Embedded Customers**;
- (d) **Suppliers**; and
- (e) **DC Converter Station** owners.

OC5.4

MONITORING

OC5.4.1

Parameters To Be monitored

**NGET** will monitor the performance of:

- (a) **BM Units** against their expected input or output derived from their **Final Physical Notification Data** and agreed **Bid-Offer Acceptances** issued under **BC2**;
- (b) compliance by **Users** with the **CC**; and
- (c) the provision by **Users** of **Ancillary Services** which they are required or have agreed to provide.

OC5.4.2

Procedure For Monitoring

OC5.4.2.1

In the event that a **BM Unit** fails persistently, in **NGET's** reasonable view, to follow, in any material respect, its expected input or output or a **User** fails persistently to comply with the **CC** and in the case of response to **Frequency, BC3** or to provide the **Ancillary Services** it is required, or has agreed, to provide, **NGET** shall notify the relevant **User** giving details of the failure and of the monitoring that **NGET** has carried out.

OC5.4.2.2

The relevant **User** will, as soon as possible, provide **NGET** with an explanation of the reasons for the failure and details of the action that it proposes to take to:

- (a) enable the **BM Unit** to meet its expected input or output or to provide the **Ancillary Services** it is required or has agreed to provide, within a reasonable period, or
- (b) in the case of a **Generating Unit** (excluding a **Power Park Unit**), **CCGT Module, Power Park Module, OTSUA** (prior to the **OTSUA Transfer Time**) or **DC Converter** to comply with the **CC** and in the case of response to **Frequency, BC3** or to provide the **Ancillary Services** it is required or has agreed to provide, within a reasonable period.

OC5.4.2.3

**NGET** and the **User** will then discuss the action the **User** proposes to take and will endeavour to reach agreement as to:



- (a) any short term operational measures necessary to protect other **Users**; and
- (b) the parameters which are to be submitted for the **BM Unit** and the effective date(s) for the application of the agreed parameters.

OC5.4.2.4 In the event that agreement cannot be reached within 10 days of notification of the failure by **NGET** to the **User**, **NGET** or the **User** shall be entitled to require a test, as set out in OC5.5 and OC5.6, to be carried out.

## OC5.5 PROCEDURE FOR TESTING

### OC5.5.1 NGET Instruction For Testing

OC5.5.1.1 **NGET** may at any time (although not normally more than twice in any calendar year in respect of any particular **BM Unit**) issue an instruction requiring a **User** to carry out a test, provided **NGET** has reasonable grounds of justification based upon:

- (a) a failure to agree arising from the process in CP.8.1; or
- (b) monitoring carried out in accordance with OC5.4.2.

OC5.5.1.2 The test, referred to in OC5.5.1.1 and carried out at a time no sooner than 48 hours from the time that the instruction was issued, on any one or more of the **User's BM Units** should only be to demonstrate that the relevant **BM Unit**:

- (a) if active in the **Balancing Mechanism**, meets the ability to operate in accordance with its submitted **Export and Import Limits**, **QPN**, **Joint BM Unit Data** and **Dynamic Parameters** and achieve its expected input or output which has been monitored under OC5.4; and
- (b) meets the requirements of the paragraphs in the **CC** which are applicable to such **BM Units**; and

in the case of a **BM Unit** comprising a **Generating Unit**, a **CCGT Module**, a **Power Park Module** or a **DC Converter** meets,

- (c) the requirements for operation in **Frequency Sensitive Mode** and compliance with the requirements for operation in **Limited Frequency Sensitive Mode** in accordance with CC.6.3.3, BC3.5.2 and BC3.7.2; or
- (d) the terms of the applicable **Supplemental Agreement** agreed with the **Generator** to have a **Fast Start Capability**; or
- (e) the **Reactive Power** capability registered with **NGET** under **OC2** which shall meet the requirements set out in CC.6.3.2. In the case of a test on a **Generating Unit** within a **CCGT Module** the instruction need not identify the particular **CCGT Unit** within the **CCGT Module** which is to be tested, but instead may specify that a test is to be carried out on one of the **CCGT Units** within the **CCGT Module**.

OC5.5.1.3 (a) The instruction referred to in OC5.5.1.1 may only be issued if the relevant **User** has submitted **Export and Import Limits** which notify that the relevant **BM Unit** is available in respect of the **Operational Day** current at the time at which the instruction is issued. The relevant **User** shall then be obliged to submit **Export and Import Limits** with a magnitude greater than zero for that **BM Unit** in respect of the time and the duration that the test is instructed to be carried out, unless that **BM Unit** would not then be available by reason of forced outage or **Planned Outage** expected prior to this instruction.

- (b) In the case of a **CCGT Module** the **Export and Import Limits** data must relate to the same **CCGT Units** which were included in respect of the **Operational Day** current at the time at which the instruction referred to in OC5.5.1.1 is issued and must include, in relation to each of the **CCGT Units** within the **CCGT Module**, details of the various data set out in BC1.A.1.3 and BC1.A.1.5, which parameters **NGET** will utilise in instructing in accordance with this **OC5** in issuing **Bid-Offer Acceptances**. The parameters shall reasonably reflect the true operating characteristics of each **CCGT Unit**.

- (c) The test referred to in OC5.5.1.1 will be initiated by the issue of instructions, which may be accompanied by a **Bid-Offer Acceptance**, under **BC2** (in accordance with the **Export and Import Limits, QPN, Joint BM Unit Data and Dynamic Parameters** which have been submitted for the day on which the test was called, or in the case of a **CCGT Unit**, in accordance with the parameters submitted under OC5.5.1.3(b)). The instructions in respect of a **CCGT Unit** within a **CCGT Module** will be in respect of the **CCGT Unit**, as provided in BC2.

OC5.5.2 User Request For Testing

- OC5.5.2.1 Where a **User** undertakes a test to demonstrate compliance with the **Grid Code** and **Bilateral Agreement** in accordance with CP.6 or CP.7 or CP.8 (other than a failure between **NGET** and a **User** to agree in CP.8.1 where OC5.5.1.1 applies) the **User** shall request permission to test using the process laid out in OC7.5.

OC5.5.3 Conduct Of Test

- OC5.5.3.1 The performance of the **BM Unit** will be recorded at **Transmission Control Centres** notified by **NGET** with monitoring at site when necessary, from voltage and current signals provided by the **User** for each **BM Unit** under CC.6.6.1.

- OC5.5.3.2 If monitoring at site is undertaken, the performance of the **BM Unit** will be recorded on a suitable recorder (with measurements, in the case of a **Synchronous Generating Unit**, taken on the **Generating Unit** Stator Terminals / on the **LV** side of the generator transformer) or in the case of a **Non-Synchronous Generating Unit** (excluding **Power Park Units**), **Power Park Module** or **DC Converter** at the point of connection (including where the **OTSUA** is operational prior to the **OTSUA Transfer Time**, the **Transmission Interface Point**) in the relevant **User's Control Room**, in the presence of a reasonable number of representatives appointed and authorised by **NGET**. If **NGET** or the **User** requests, monitoring at site will include measurement of the parameters set out in OC5.A.1 or OC5.A.2 as appropriate.

- OC5.5.3.3 The **User** is responsible for carrying out the test and retains the responsibility for the safety of personnel and plant during the test.

OC5.5.4 Test And Monitoring Assessment

The criteria must be read in conjunction with the full text under the Grid Code reference. The **BM Unit, CCGT Module, Power Park Module** or **Generating Unit** (excluding **Power Park Units**) and **OTSUA** will pass the test the criteria below are met:

| <u>Parameter to be Tested</u>          |                     | <u>Criteria against which the test results will be assessed by NGET.</u>   |
|--|---------------------|--|
| Voltage Quality                        | Harmonic Content    | CC.6.1.5(a) Measured harmonic emissions do not exceed the limits specified in the <b>Bilateral Agreement</b> or where no such limits are specified, the relevant planning level specified in G5/4.   |
|  | Phase Unbalance     | CC.6.1.5(b), The measured maximum <b>Phase (Voltage) Unbalance</b> on the <b>National Electricity Transmission System</b> should remain, in England and Wales, below 1% and, in Scotland, below 2% and <b>Offshore</b> will be defined in relevant <b>Bilateral Agreement</b> .<br><br>CC.6.1.6 In England and Wales, measured infrequent short duration peaks in <b>Phase (Voltage) Unbalance</b> should not exceed the maximum value stated in the <b>Bilateral Agreement</b> .          |
|  | Voltage Fluctuation | CC.6.1.7(a) In England and Wales, measured voltage fluctuations at the <b>Point of Common Coupling</b> shall not exceed 1% of the voltage level for step changes. Measured voltage excursions other than step changes may be allowed up to a level of 3%. In Scotland, measured voltage fluctuations at a <b>Point of Common Coupling</b> shall not exceed the limits set out in <b>Engineering Recommendation P28</b> .   |
|  | Flicker             | CC.6.1.7(b) Measured voltage fluctuations at a <b>Point of Common Coupling</b> shall not exceed, for voltages above 132kV, <b>Flicker Severity (Short Term)</b> of 0.8 Unit and <b>Flicker Severity (Long Term)</b> of 0.6 Unit, and, for voltages at 132kV and below, shall not exceed <b>Flicker Severity (Short Term)</b> of 1.0 Unit and <b>Flicker Severity (Long Term)</b> of 0.8 Unit, as set out in <b>Engineering Recommendation P28</b> as current at the <b>Transfer Date</b> . |
|  | Voltage Fluctuation | CC.6.1.8 <b>Offshore</b> , measured voltage fluctuations at the <b>Point of Common Coupling</b> shall not exceed the limits set out in the <b>Bilateral Agreement</b> .  |
|  | Fault Clearance     | Fault Clearance Times  |
| <b>Back Up Protection</b>              |                     | CC.6.2.2.2.2(b), CC.6.2.3.1.1(b) , <b>Bilateral Agreement</b>  |
| <b>Circuit Breaker Fail Protection</b> |                     | CC.6.2.2.2.2(c), CC.6.2.3.1.1(c)   |

| <u>Parameter to be Tested</u> |  | <u>Criteria against which the test results will be assessed by NGET.</u>  |
|-------------------------------|--|---|
|                               | Reactive Capability                                      | <p>CC.6.3.2 (and in the case of CC.6.3.2(e)(iii), the <b>Bilateral Agreement</b>), CC.6.3.4, <b>Ancillary Services Agreement</b>.</p> <p>For a test initiated under OC.5.5.1.1 the <b>Generating Unit, DC Converter or Power Park Module</b> <u>or (prior to the OTSUA Transfer Time) OTSUA</u> will pass the test if it is within <math>\pm 5\%</math> of the reactive capability registered with NGET under OC2. the duration of the test will be for a period of upto 60 minutes during which period the system voltage at the <b>Grid Entry Point</b> for the relevant <b>Generating Unit, DC Converter or Power Park Module</b> <u>or Interface Point in the case of OTSUA</u> will be maintained by the <b>Generator or DC Converter Station</b> owner at the voltage specified pursuant to BC2.8 by adjustment of <b>Reactive Power</b> on the remaining <b>Generating Unit, DC Converter or Power Park Modules</b> <u>or OTSUA</u>, if necessary. Any test performed in respect of an <b>Embedded Medium Power Station</b> not subject to a <b>Bilateral Agreement</b> or, an <b>Embedded DC Converter Station</b> not subject to a <b>Bilateral Agreement</b> shall be as confirmed pursuant to OC5.8.3.</p> <p>Measurements of the <b>Reactive Power</b> output under steady state conditions should be consistent with Grid Code requirements i.e. fully available within the voltage range <math>\pm 5\%</math> at 400kV, 275kV and 132kV and lower voltages.</p> |
| Governor / Frequency Control  | Primary Secondary and High Frequency Response            | <p><b>Ancillary Services Agreement</b>, CC.6.3.7 and where applicable CC.A.3</p> <p>For a test initiated under OC.5.5.1.1 the measured response in MW/Hz is within <math>\pm 5\%</math> of the level of response specified in the <b>Ancillary Services Agreement</b> for that <b>Genset</b>.</p>   |
|                               | Stability with Voltage                                   | CC.6.3.4  |
|                               | Governor / Load / Frequency Controller System Compliance | CC.6.3.6(a), CC.6.3.7, CC.6.3.9, CC8.1, where applicable CC.A.3, BC3.5, BC3.6, BC3.7  |
|                               | Output at Reduced System Frequency                       | CC.6.3.3 - For variations in <b>System Frequency</b> exceeding 0.1Hz within a period of less than 10 seconds, the <b>Active Power</b> output is within $\pm 0.2\%$ of the requirements of CC.6.3.3 when monitored at prevailing external air temperatures of up to 25°C., BC3.5.1   |
|                               | <b>Fast Start</b>  | <b>Ancillary Services Agreement</b> requirements  |
|                               | <b>Black Start</b>                                       | OC5.7   |

| <u>Parameter to be Tested</u> |   | <u>Criteria against which the test results will be assessed by NGET.</u>   |
|-------------------------------|---|--|
|                               |   |  |
|                               | Excitation/Voltage <b>Control System</b>  | CC.6.3.6(b), CC.6.3.8, CC.A.6 or CC.A.7 as applicable, BC2.11.2, <b>Bilateral Agreement</b>  |
|                               | Fault Ride Through  | CC.6.3.15, CC.A.4.A or CC.A.4.B as applicable  |
| Dynamic Parameters            | <b>Export and Import Limits, QPN, Joint BM Unit Data and Dynamic Parameters</b> | BC2<br>The <b>Export and Import Limits, QPN, Joint BM Unit Data and Dynamic Parameters</b> under test are within 2½% of the declared value being tested.   |
|                               | Synchronisation time  | BC2.5.2.3<br><b>Synchronisation</b> takes place within ±5 minutes of the time it should have achieved <b>Synchronisation</b> .   |
|                               | Run-up rates  | BC2<br>Achieves the instructed output and, where applicable, the first and/or second intermediate breakpoints, each within ±3 minutes of the time it should have reached such output and breakpoints from <b>Synchronisation</b> (or break point, as the case may be), calculated from the run-up rates in its <b>Dynamic Parameters</b> . |
|                               | Run-down rates  | BC2<br>Achieves the instructed output and, where applicable, the first and/or second intermediate breakpoints, each within ±5 minutes of the time it should have reached such output and breakpoints from <b>Synchronisation</b> (or break point, as the case may be), calculated from the run-up rates in its <b>Dynamic Parameters</b> . |

OC5.5.4.1 The duration of the **Dynamic Parameter** tests in the above table will be consistent with and sufficient to measure the relevant expected input or output derived from the **Final Physical Notification Data** and **Bid-Offer Acceptances** issued under **BC2** which are still in dispute following the procedure in OC5.4.2.

OC5.5.4.2 Due account will be taken of any conditions on the **System** which may affect the results of the test. The relevant **User** must, if requested, demonstrate, to **NGET's** reasonable satisfaction, the reliability of the suitable recorders, disclosing calibration records to the extent appropriate.

OC5.5.5 Test Failure / Re-test

OC5.5.5.1 If the **BM Unit, CCGT Modules, Power Park Module, OTSUA, or Generating Unit** (excluding **Power Park Units**) concerned fails to pass the test instructed by **NGET** under OC5.5.1.1 the **User** must provide **NGET** with a written report specifying in reasonable detail the reasons for any failure of the test so far as they are then known to the **User** after due and careful enquiry. This must be provided within five **Business Days** of the test.

- OC5.5.5.2 If in **NGET's** reasonable opinion the failure to pass the test relates to compliance with the **CC** then **NGET** may invoke the process detailed in CP.8.2 to CP.11.
- OC5.5.5.3 If a dispute arises relating to the failure, **NGET** and the relevant **User** shall seek to resolve the dispute by discussion, and, if they fail to reach agreement, the **User** may by notice require **NGET** to carry out a re-test on 48 hours' notice which shall be carried out following the procedure set out in OC5.5.3 and OC5.5.4 and subject as provided in OC5.5.1.3, as if **NGET** had issued an instruction at the time of notice from the **User**.
- OC5.5.6 Dispute Following Re-Test
- If the **BM Unit**, **CCGT Module**, **Power Park Module**, **OTSUA** or **Generating Unit** (excluding **Power Park Units**) in **NGET's** view fails to pass the re-test and a dispute arises on that re-test, either party may use the **Disputes Resolution Procedure** for a ruling in relation to the dispute, which ruling shall be binding.
- OC5.6 DISPUTE RESOLUTION
- OC5.6.1 If following the procedure set out in OC5.5 it is accepted that the **BM Unit**, **CCGT Module**, **Power Park Module**, **OTSUA (prior to the OTSUA Transfer Time)** or **Generating Unit** (excluding **Power Park Units**) has failed the test or re-test (as applicable), the **User** shall within 14 days, or such longer period as **NGET** may reasonably agree, following such failure, submit in writing to **NGET** for approval the date and time by which the **User** shall have brought the **BM Unit** concerned to a condition where it complies with the relevant requirement. **NGET** will not unreasonably withhold or delay its approval of the **User's** proposed date and time submitted. Should **NGET** not approve the **User's** proposed date or time (or any revised proposal), the **User** should amend such proposal having regard to any comments **NGET** may have made and re-submit it for approval.
- OC5.6.2 If a **BM Unit** fails the test, the **User** shall submit revised **Export and Import Limits**, **QPN**, **Joint BM Unit Data** and/or **Dynamic Parameters**, or in the case of a **BM Unit** comprising a **Generating Unit**, **CCGT Module**, **DC Converter**, **OTSUA (prior to the OTSUA Transfer Time)** or **Power Park Module**, the **User** may amend, with **NGET's** approval, the relevant registered parameters of that **Generating Unit**, **CCGT Module**, **DC Converter**, **OTSUA (prior to the OTSUA Transfer Time)** or **Power Park Module**, as the case may be, relating to the criteria, for the period of time until the **BM Unit** can achieve the parameters previously registered, as demonstrated in a re-test.
- OC5.6.3 Once the **User** has indicated to **NGET** the date and time that the **BM Unit**, **CCGT Module**, **Power Park Module**, or **Generating Unit** (excluding **Power Park Units**) or **OTSUA (prior to the OTSUA Transfer Time)** can achieve the parameters previously registered or submitted, **NGET** shall either accept this information or require the **User** to demonstrate the restoration of the capability by means of a repetition of the test referred to in OC5.5.3 by an instruction requiring the **User** on 48 hours notice to carry out such a test. The provisions of this OC5.6 will apply to such further test.
- OC5.7 BLACK START TESTING
- OC5.7.1 General
- (a) **NGET** may require a **Generator** with a **Black Start Station** to carry out a test (a "**Black Start Test**") on a **Genset** in a **Black Start Station** either while the **Black Start Station** remains connected to an external alternating current electrical supply (a "**BS Unit Test**") or while the **Black Start Station** is disconnected from all external alternating current electrical supplies (a "**BS Station Test**"), in order to demonstrate that a **Black Start Station** has a **Black Start Capability**.
- (b) Where **NGET** requires a **Generator** with a **Black Start Station** to carry out a **BS Unit Test**, **NGET** shall not require the **Black Start Test** to be carried out on more than one **Genset** at that **Black Start Station** at the same time, and would not, in the absence of exceptional circumstances, expect any of the other **Genset** at the **Black Start Station** to be directly affected by the **BS Unit Test**.

- (c) **NGET** may require a **Generator** with a **Black Start Station** to carry out a **BS Unit Test** at any time (but will not require a **BS Unit Test** to be carried out more than once in each calendar year in respect of any particular **Genset** unless it can justify on reasonable grounds the necessity for further tests or unless the further test is a re-test, and will not require a **BS Station Test** to be carried out more than once in every two calendar years in respect of any particular **Genset** unless it can justify on reasonable grounds the necessity for further tests or unless the further test is a re-test).
- (d) When **NGET** wishes a **Generator** with a **Black Start Station** to carry out a **Black Start Test**, it shall notify the relevant **Generator** at least 7 days prior to the time of the **Black Start Test** with details of the proposed **Black Start Test**.

#### OC5.7.2 Procedure For A Black Start Test

The following procedure will, so far as practicable, be carried out in the following sequence for **Black Start Tests**:

##### OC5.7.2.1 BS Unit Tests

- (a) The relevant **Generating Unit** shall be **Synchronised** and **Loaded**;
- (b) All the **Auxiliary Gas Turbines** and/or **Auxiliary Diesel Engines** in the **Black Start Station** in which that **Generating Unit** is situated, shall be **Shutdown**.
- (c) The **Generating Unit** shall be **De-Loaded** and **De-Synchronised** and all alternating current electrical supplies to its **Auxiliaries** shall be disconnected.
- (d) The **Auxiliary Gas Turbine(s)** or **Auxiliary Diesel Engine(s)** to the relevant **Generating Unit** shall be started, and shall re-energise the **Unit Board** of the relevant **Generating Unit**.
- (e) The **Auxiliaries** of the relevant **Generating Unit** shall be fed by the **Auxiliary Gas Turbine(s)** or **Auxiliary Diesel Engine(s)**, via the **Unit Board**, to enable the relevant **Generating Unit** to return to **Synchronous Speed**.
- (f) The relevant **Generating Unit** shall be **Synchronised** to the **System** but not **Loaded**, unless the appropriate instruction has been given by **NGET** under **BC2**.

##### OC5.7.2.2 BS Station Test

- (a) All **Generating Units** at the **Black Start Station**, other than the **Generating Unit** on which the **Black Start Test** is to be carried out, and all the **Auxiliary Gas Turbines** and/or **Auxiliary Diesel Engines** at the **Black Start Station**, shall be **Shutdown**.
- (b) The relevant **Generating Unit** shall be **Synchronised** and **Loaded**.
- (c) The relevant **Generating Unit** shall be **De-Loaded** and **De-Synchronised**.
- (d) All external alternating current electrical supplies to the **Unit Board** of the relevant **Generating Unit**, and to the **Station Board** of the relevant **Black Start Station**, shall be disconnected.
- (e) An **Auxiliary Gas Turbine** or **Auxiliary Diesel Engine** at the **Black Start Station** shall be started, and shall re-energise either directly, or via the **Station Board**, the **Unit Board** of the relevant **Generating Unit**.
- (f) The provisions of OC5.7.2.1 (e) and (f) shall thereafter be followed.

OC5.7.2.3 All **Black Start Tests** shall be carried out at the time specified by **NGET** in the notice given under OC5.7.1(d) and shall be undertaken in the presence of a reasonable number of representatives appointed and authorised by **NGET**, who shall be given access to all information relevant to the **Black Start Test**.

##### OC5.7.2.4 Failure of a Black Start Test

A **Black Start Station** shall fail a **Black Start Test** if the **Black Start Test** shows that it does not have a **Black Start Capability** (ie. if the relevant **Generating Unit** fails to be **Synchronised** to the **System** within two hours of the **Auxiliary Gas Turbine(s)** or **Auxiliary Diesel Engine(s)** being required to start).

- OC5.7.2.5 If a **Black Start Station** fails to pass a **Black Start Test** the **Generator** must provide **NGET** with a written report specifying in reasonable detail the reasons for any failure of the test so far as they are then known to the **Generator** after due and careful enquiry. This must be provided within five **Business Days** of the test. If a dispute arises relating to the failure, **NGET** and the relevant **Generator** shall seek to resolve the dispute by discussion, and if they fail to reach agreement, the **Generator** may require **NGET** to carry out a further **Black Start Test** on 48 hours notice which shall be carried out following the procedure set out in OC5.7.2.1 or OC5.7.2.2 as the case may be, as if **NGET** had issued an instruction at the time of notice from the **Generator**.
- OC5.7.2.6 If the **Black Start Station** concerned fails to pass the re-test and a dispute arises on that re-test, either party may use the **Disputes Resolution Procedure** for a ruling in relation to the dispute, which ruling shall be binding.
- OC5.7.2.7 If following the procedure in OC5.7.2.5 and OC5.7.2.6 it is accepted that the **Black Start Station** has failed the **Black Start Test** (or a re-test carried out under OC5.7.2.5), within 14 days, or such longer period as **NGET** may reasonably agree, following such failure, the relevant **Generator** shall submit to **NGET** in writing for approval, the date and time by which that **Generator** shall have brought that **Black Start Station** to a condition where it has a **Black Start Capability** and would pass the **Black Start Test**, and **NGET** will not unreasonably withhold or delay its approval of the **Generator's** proposed date and time submitted. Should **NGET** not approve the **Generator's** proposed date and time (or any revised proposal) the **Generator** shall revise such proposal having regard to any comments **NGET** may have made and resubmit it for approval.
- OC5.7.2.8 Once the **Generator** has indicated to **NGET** that the **Generating Station** has a **Black Start Capability**, **NGET** shall either accept this information or require the **Generator** to demonstrate that the relevant **Black Start Station** has its **Black Start Capability** restored, by means of a repetition of the **Black Start Test** referred to in OC5.7.1(d) following the same procedure as for the initial **Black Start Test**. The provisions of this OC5.7.2 will apply to such test.
- OC5.8 PROCEDURES APPLYING TO EMBEDDED MEDIUM POWER STATION NOT SUBJECT TO A BILATERAL AGREEMENT AND EMBEDDED DC CONVERTER STATIONS NOT SUBJECT TO A BILATERAL AGREEMENT
- OC5.8.1 Compliance Statement
- Each **Network Operator** shall ensure that each **Embedded Person** provides to the **Network Operator** upon **NGET's** request:
- (a) written confirmation that each such **Generating Unit**, **Power Park Module** or **DC Converter** complies with the requirements of the **CC**; and
  - (b) evidence, where requested, reasonably satisfactory to **NGET**, of such compliance. Such a request shall not normally be made by **NGET** more than twice in any calendar year in respect of any **Generator's Generating Unit** or **Power Park Module** or **DC Converter** owner's **DC Converter**.
- The **Network Operator** shall provide the evidence or written confirmation required under OC5.8.1 (a) and (b) forthwith upon receipt to **NGET**.
- OC5.8.2 Network Operator's Obligations To Facilitate Tests
- If:
- (a) the **Network Operator** fails to procure the confirmation referred to at OC5.8.1(a); or
  - (b) the evidence of compliance is not to **NGET's** reasonable satisfaction,
- then, **NGET** shall be entitled to require the **Network Operator** to procure access upon terms reasonably satisfactory to **NGET** to enable **NGET** to witness the **Embedded Person** carrying out the tests referred to in OC5.8.3 in respect of the relevant **Embedded Medium Power Station** or **Embedded DC Converter Station**.
- OC5.8.3 Testing Of Embedded Medium Power Stations Not Subject To A Bilateral Agreement Or Embedded DC Converter Stations Not Subject To A Bilateral Agreement



**NGET** may, in accordance with the provisions of OC5.8.2, at any time (although not normally more than twice in any calendar year in respect of any particular **Embedded Medium Power Station** not subject to a **Bilateral Agreement** or **Embedded DC Converter Station** not subject to a **Bilateral Agreement**) issue an instruction requiring the **Network Operator** within whose **System** the relevant **Medium Power Station** not subject to a **Bilateral Agreement** or **DC Converter Station** not subject to a **Bilateral Agreement** is **Embedded**, to require the **Embedded Person** to carry out a test.

Such test shall be carried out at a time no sooner than 48 hours from the time that the instruction was issued, on any one or more of the **Generating Units, Power Park Module** or **DC Converter** comprising part of the relevant **Embedded Medium Power Station** or **Embedded DC Converter Station** and should only be to demonstrate that:

- (a) the relevant **Generating Unit, Power Park Module** or **DC Converter** meets the requirements of the paragraphs in the **CC** which are applicable to such **Generating Units, Power Park Module** or **DC Converter**;
- (b) the **Reactive Power** capability registered with **NGET** under **OC2** meets the requirements set out in CC.6.3.2.

The instruction may only be issued where, following consultation with the relevant **Network Operator, NGET** has:

- (a) confirmed to the relevant **Network Operator** the manner in which the test will be conducted, which shall be consistent with the principles established in OC5.5.3; and
- (b) received confirmation from the relevant **Network Operator** that the relevant **Generating Unit, Power Park Module** or **DC Converter** would not then be unavailable by reason of forced outage or **Planned Outage** expected prior to the instruction.

The relevant **Network Operator** is responsible for ensuring the performance of any test so required by **NGET** and the **Network Operator** shall ensure that the **Embedded Person** retains the responsibility for ensuring the safety of personnel and plant during the test.

#### OC5.8.4

##### Test Failures/Re-Tests And Disputes

The relevant **Network Operator** shall:

- (a) ensure that provisions equivalent to OC5.5.5, OC5.5.6 and OC5.6 apply to **Embedded Medium Power Stations** not the subject of a **Bilateral Agreement** or **Embedded DC Converter Stations** not the subject of a **Bilateral Agreement** within its **System** in respect of test failures, re-tests and disputes as to test failures and re-tests;
- (b) ensure that the provisions equivalent to OC5.5.5, OC5.5.6 and OC5.6 referred to in OC5.8.4(a) are effective so that **NGET** may require, if it so wishes, the provision to it of any reports or other information equivalent to those or that to which **NGET** would be entitled in relation to test failures, re-tests and disputes as to test failures and re-tests under the provisions of OC5.5.5, OC5.5.6 and OC5.6; and
- (c) the provisions equivalent to OC5.5.5, OC5.5.6 and OC5.6 referred to in OC5.8.4(a) are effective to permit **NGET** to conduct itself and take decisions in such a manner in relation to test failures, re-tests and disputes as to test failures and re-tests in respect of **Embedded Medium Power Stations** not the subject of a **Bilateral Agreement** or **Embedded DC Converter Stations** not the subject of a **Bilateral Agreement** as it is able to conduct itself and take decisions in relation to test failures, re-tests and disputes as to test failures and re-tests under OC5.5.5, OC5.5.6 and OC5.6.

## APPENDIX 1 - ONSITE SIGNAL PROVISION FOR WITNESSING TESTS

OC5.A.1.1 During any tests witnessed on-site by **NGET**, the following signals shall be provided to **NGET** by the **Generator, Generator undertaking OTSDUW** or **DC Converter Station** owner in accordance with CC.6.6.2:

### OC5.A.1.2 Synchronous Generating Units

- (a) All Tests
  - MW - **Active Power** at **Generating Unit** terminals
- (b) Reactive & Excitation System
  - MVA<sub>r</sub> - **Reactive Power** at **Generating Unit** terminals
  - V<sub>t</sub> - **Generating Unit** terminal voltage
  - E<sub>fd</sub> - **Generating Unit** field voltage and/or main exciter field voltage
  - I<sub>fd</sub> - **Generating Unit** field current (where possible)
  - **Power System Stabiliser** output, where applicable.
  - Noise - Injected noise signal (where applicable and possible)
- (c) Governor System & Frequency Response
  - F<sub>sys</sub> - **System Frequency**
  - F<sub>inj</sub> - Injected Speed Reference
  - Logic - Stop / Start Logic Signal

For Gas Turbines:

- GT Fuel Demand
- GT Fuel Valve Position
- GT Inlet Guide Vane Position
- GT Exhaust Gas Temperature

For Steam Turbines at  $\geq 1$ Hz:

- Pressure before Turbine Governor Valves
- Turbine Governor Valve Positions
- Governor Oil Pressure\*
- Boiler Pressure Set Point \*
- Superheater Outlet Pressure \*
- Pressure after Turbine Governor Valves\*
- Boiler Firing Demand\*

\*Where applicable (typically not in CCGT module)

For Hydro Plant:

- Speed Governor Demand Signal
- Actuator Output Signal
- Guide Vane / Needle Valve Position

- (d) Compliance with
  - F<sub>sys</sub> - **System Frequency**

CC.6.3.3

- Finj - Injected Speed Reference
- Appropriate control system parameters as agreed with **NGET** (See OC5.A.2.9)

OC5.A.1.3 Power Park Modules, **OTSUA** and DC Converters

Each **Power Park Module** and **DC Converters** at **Grid Entry Point** or **User System Entry Point**

(a) Real Time on site.

- Total **Active Power** (MW)
- Total **Reactive Power** (MVar)
- Line-line Voltage (kV)
- **System Frequency** (Hz)

(b) Real Time on site or Downloadable

- Injected frequency signal (Hz) or test logic signal (Boolean) when appropriate
- Injected voltage signal (per unit voltage) or test logic signal (Boolean) when appropriate
- In the case of an **Onshore Power Park Module** the **Onshore Power Park Module** site voltage (MV) (kV)
- **Power System Stabiliser** output, where appropriate
- In the case of a **Power Park Module** or **DC Converter** where the **Reactive Power** is provided by from more than one **Reactive Power** source, the individual **Reactive Power** contributions from each source, as agreed with **NGET**.
- In the case of **DC Converters** appropriate control system parameters as agreed with **NGET** (See OC5.A.4)
- In the case of an **Offshore Power Park Module** the Total **Active Power** (MW) and the Total **Reactive Power** (MVar) at the **Offshore Grid Entry Point**

(c) Real Time on site or Downloadable

- Available power for **Power Park Module** (MW)
- Power source speed for **Power Park Module** (e.g. wind speed) (m/s) when appropriate
- Power source direction for **Power Park Module** (degrees) when appropriate

See OC5.A.1.3.1

OC5.A.1.3.1 **NGET** accept that the signals specified in OC5.A.1.3(c) may have lower effective sample rates than those required in CC.6.6.2 although any signals supplied for connection to **NGET's** recording equipment which do not meet at least the sample rates detailed in CC.6.6.2 should have the actual sample rates indicated to **NGET** before testing commences.

OC5.A.1.3.2 For all **NGET** witnessed testing either;

- (i) the **Generator** or **DC Converter Station** owner shall provide to **NGET** all signals outlined in OC5.A.1.3 direct from the **Power Park Module** control system without any attenuation, delay or filtering which would result in the inability to fully demonstrate the objectives of the test, or identify any potential safety or plant instability issues, and with a signal update rate corresponding to CC.6.6.2.1; or
- (ii) in the case of **Onshore Power Park Modules** the **Generator** or **DC Converter Station** owner shall provide signals OC5.A.1.3(a) direct from one or more transducer(s) connected to current and voltage transformers for monitoring in real time on site; or,

- (iii) In the case of **Offshore Power Park Modules** and **OTSUA** signals OC5.A.1.3(a) will be provided at the **Interface Point** by the **Offshore Transmission Licensee** pursuant to the STC or by the **Generator** when **OTSDUW Arrangements** apply.

OC5.A.1.3.3 Options OC5.A.1.3.2 (ii) and (iii) will only be available on condition that;

- (a) all signals outlined in OC5.A.1.3 are recorded and made available to **NGET** by the **Generator** or **DC Converter Station** owner from the **Power Park Module** or **OTSUA** or **DC Converter** control systems as a download once the testing has been completed; and
- (b) the full test results are provided by the **Generator** or **DC Converter Station** owner within 2 working days of the test date to **NGET** unless **NGET** agrees otherwise; and
- (c) all data is provided with a sample rate in accordance with CC.6.6.2.2 unless **NGET** agrees otherwise; and
- (d) in **NGET's** reasonable opinion the solution does not unreasonably add a significant delay between tests or impede the volume of testing which can take place on the day.

OC5.A.1.3.4 In the case of where transducers connected to current and voltage transformers are installed (OC5.A.1.3.3 (ii) and (iii)), the transducers shall meet the following specification

- (a) The transducer(s) shall be permanently installed to easily allow safe testing at any point in the future, and to avoid a requirement for recalibration of the current transformers and voltage transformers.
- (b) The transducer(s) should be directly connected to the metering quality current transformers and voltage transformers or similar.
- (c) The transducers shall either have a response time no greater than 50ms to reach 90% of output, or no greater than 300ms to reach 99.5%.

## APPENDIX 2 - COMPLIANCE TESTING OF SYNCHRONOUS PLANT

### OC5.A.2.1 Scope

OC5.A.2.1.1 This Appendix sets out the tests contained therein to demonstrate compliance with the relevant clauses of the **Connection Conditions** of the Grid Code. This Appendix shall be read in conjunction with the **CP** with regard to the submission of the reports to **NGET**.

OC5.A.2.1.2 The tests specified in this Appendix will normally be sufficient to demonstrate compliance however **NGET** may:

- (i) agree an alternative set of tests provided **NGET** deem the alternative set of tests sufficient to demonstrate compliance with the **Grid Code** and **Bilateral Agreement**; and/or
- (ii) require additional or alternative tests if information supplied to **NGET** during the compliance process suggests that the tests in this Appendix will not fully demonstrate compliance with the relevant section of the **Grid Code** or **Bilateral Agreement**.
- (iii) Agree a reduced set of tests for subsequent **Generating Units** following successful completion of the first **Generating Unit** tests in the case of a **Power Station** comprised of two or more **Generating Units** which **NGET** reasonably considers to be identical.

If:

- (a) the tests performed pursuant to OC5.A.2.1.2(iii) in respect of subsequent **Generating Units** do not replicate the full tests for the first **Generating Unit**, or
- (b) any of the tests performed pursuant to OC5.A.2.1.2(iii) do not fully demonstrate compliance with the relevant aspects of the **Grid Code**, **Ancillary Services Agreement** and / or **Bilateral Agreement**,

then notwithstanding the provisions above, the full testing requirements set out in this Appendix will be applied.

OC5.A.2.1.3 The **Generator** is responsible for carrying out the tests set out in and in accordance with this Appendix and the **Generator** retains the responsibility for the safety of personnel and plant during the test. **NGET** will witness all of the tests outlined or agreed in relation to this Appendix unless **NGET** decides and notifies the **Generator** otherwise. Reactive Capability tests may be witnessed by **NGET** remotely from the **NGET** control centre. For all on site **NGET** witnessed tests the **Generator** should ensure suitable representatives from the **Generator** and manufacturer (if appropriate) are available on site for the entire testing period. In all cases the **Generator** shall provide suitable monitoring equipment to record all relevant test signals as outlined below in OC5.A.3.1.5.

OC5.A.2.1.6 The **Generator** shall submit a schedule of tests to **NGET** in accordance with CP.4.3.1

OC5.A.2.1.7 Prior to the testing of a **Generating Unit** the **Generator** shall complete the **Integral Equipment Test** procedure in accordance with OC.7.5

OC5.A.2.1.8 Full **Generating Unit** testing as required by CP.7.2 is to be completed as defined in OC5.A.2.2 through to OC5.A.2.9

### OC5.A.2.2 Excitation System Open Circuit Step Response Tests

OC5.A.2.2.1 The open circuit step response of the **Excitation System** will be tested by applying a voltage step change from 90% to 100% of the nominal **Generating Unit** terminal voltage, with the **Generating Unit** on open circuit and at rated speed.

- OC5.A.2.2.1 The test shall be carried out prior to synchronisation in accordance with CP.6.4. This is not witnessed by **NGET** unless specifically requested by **NGET**. Where **NGET** is not witnessing the tests, the **Generator** shall supply the recordings of the following signals to **NGET** in an electronic spreadsheet format:
- Vt - **Generating Unit** terminal voltage
  - Efd - **Generating Unit** field voltage or main exciter field voltage
  - I<sub>fd</sub>- **Generating Unit** field current (where possible)
  - Step injection signal
- OC5.A.2.2.3 Results shall be legible, identifiable by labelling, and shall have appropriate scaling.
- OC5.A.2.3 Open & Short Circuit Saturation Characteristics
- OC5.A.2.3.1 The test shall normally be carried out prior to synchronisation in accordance with CP.6.4. Manufacturer factory test results may be used where appropriate or manufacturers factory type test results may be used if agreed by **NGET**.
- OC5.A.2.3.2 This is not witnessed by **NGET**. Graphical and tabular representations of the results in an electronic spreadsheet format showing per unit open circuit terminal voltage and short circuit current versus per unit field current shall be submitted to **NGET**.
- OC5.A.2.3.3 Results shall be legible, identifiable by labelling, and shall have appropriate scaling.
- OC5.A.2.4 Excitation System On-Load Tests
- OC5.A.2.4.1 The time domain performance of the **Excitation System** shall be tested by application of voltage step changes corresponding to 1% and 2% of the nominal terminal voltage.
- OC5.A.2.4.2 Where a **Power System Stabiliser** is present:
- (i) The **PSS** must only be commissioned in accordance with BC2.11.2. When a **PSS** is switched on for the first time as part of on-load commissioning or if parameters have been adjusted the **Generator** should consider reducing the **PSS** output gain by at least 50% and should consider reducing the limits on **PSS** output by at least a factor of 5 to prevent unexpected **PSS** action affecting the stability of the **Generating Unit** or the **National Electricity Transmission System**.
  - (ii) The time domain performance of the **Excitation System** shall be tested by application of voltage step changes corresponding to 1% and 2% of the nominal terminal voltage, repeating with and without the **PSS** in service.
  - (iii) The frequency domain tuning of the **PSS** shall also be demonstrated by injecting a 0.2Hz-3Hz band limited random noise signal into the **Automatic Voltage Regulator** reference with the **Generating Unit** operating at points specified by **NGET** (up to rated MVA output).
  - (iv) The **PSS** gain margin shall be tested by increasing the **PSS** gain gradually to threefold and observing the **Generating Unit** steady state **Active Power** output.
  - (v) The interaction of the **PSS** with changes in **Active Power** shall be tested by application of a +0.5Hz frequency injection to the governor while the **Generating Unit** is selected to **Frequency Sensitive Mode**.
  - (vi) If the **Generating Unit** is of the pump storage type then the step tests shall be carried out, with and without the **PSS**, in the pumping mode in addition to the generating mode.
  - (vii) Where the **Bilateral Agreement** requires that the **PSS** is in service at a specified loading level additional testing witnessed by **NGET** will be required during the commissioning process before the **Generating Unit** or **CCGT Module** may exceed this output level.
  - (viii) Where the **Excitation System** includes a **PSS**, the **Generator** shall provide a suitable noise source to facilitate noise injection testing.

OC5.A.2.4.3 The following typical procedure is provided to assist **Generators** in drawing up their own site specific procedures for the **NGET** witnessed **PSS** Tests.

| Test | Injection   | Notes |
|------|---|-------|
|      | Synchronous Generator running rated MW, unity pf, PSS Switched Off  |       |
| 1    | <ul style="list-style-type: none"> <li>• Record steady state for 10 seconds</li> <li>• Inject +1% step to AVR Voltage Reference and hold for at least 10 seconds until stabilised</li> <li>• Remove step returning AVR Voltage Reference to nominal and hold for at least 10 seconds</li> </ul> |       |
| 2    | <ul style="list-style-type: none"> <li>• Record steady state for 10 seconds</li> <li>• Inject +2% step to AVR Voltage Reference and hold for at least 10 seconds until stabilised</li> <li>• Remove step returning AVR Voltage Reference to nominal and hold for at least 10 seconds</li> </ul> |       |
| 3    | <ul style="list-style-type: none"> <li>• Inject band limited (0.2-3Hz) random noise signal into voltage reference and measure frequency spectrum of Real Power.</li> <li>• Remove noise injection.</li> </ul>   |       |
|      | Switch On Power System Stabiliser   |       |
| 4    | <ul style="list-style-type: none"> <li>• Record steady state for 10 seconds</li> <li>• Inject +1% step to AVR Voltage Reference and hold for at least 10 seconds until stabilised</li> <li>• Remove step returning AVR Voltage Reference to nominal and hold for at least 10 seconds</li> </ul> |       |
| 5    | <ul style="list-style-type: none"> <li>• Record steady state for 10 seconds</li> <li>• Inject +2% step to AVR Voltage Reference and hold for at least 10 seconds until stabilised</li> <li>• Remove step returning AVR Voltage Reference to nominal and hold for at least 10 seconds</li> </ul> |       |
| 6    | <ul style="list-style-type: none"> <li>• Increase PSS gain at 30 second intervals. i.e. x1 – x1.5 – x2 – x2.5 – x3</li> <li>• Return PSS gain to initial setting</li> </ul>   |       |
| 7    | <ul style="list-style-type: none"> <li>• Inject band limited (0.2-3Hz) random noise signal into voltage reference and measure frequency spectrum of Real Power.</li> <li>• Remove noise injection.</li> </ul>   |       |

|   |   |  |
|---|---|--|
| 8 | <ul style="list-style-type: none"> <li>• Select the governor to FSM</li> <li>• Inject +0.5 Hz step into governor.</li> <li>• Hold until generator MW output is stabilised</li> <li>• Remove step</li> </ul> |  |
|---|---|--|

OC5.A.2.5 Under-excitation Limiter Performance Test

OC5.A.2.5.1 Initially the performance of the **Under-excitation Limiter** should be checked by moving the limit line close to the operating point of the **Generating Unit** when operating close to unity power factor. The operating point of the **Generating Unit** is then stepped into the limit by applying a 2% decrease in **Automatic Voltage Regulator** reference voltage.

OC5.A.2.5.2 The final performance of the **Under-excitation Limiter** shall be demonstrated by testing its response to a step change corresponding to a 2% decrease in **Automatic Voltage Regulator** reference voltage when the **Generating Unit** is operating just off the limit line, at the designed setting as indicated on the **Performance Chart** submitted to **NGET** under OC2.

OC5.A.2.5.3 Where possible the **Under-excitation Limiter** should also be tested by operating the tap-changer when the **Generating Unit** is operating just off the limit line, as set up.

OC5.A.2.5.4 The **Under-excitation Limiter** will normally be tested at low **Active Power** output and at maximum **Active Power** output (**Registered Capacity**).

OC5.A.2.5.5 The following typical procedure is provided to assist **Generators** in drawing up their own site specific procedures for the **NGET** witnessed **Under-excitation Limiter** Tests.

| Test | Injection  | Notes |
|------|--|-------|
|      | Synchronous generator running rated MW at unity power factor. Under-excitation limit temporarily moved close to the operating point of the generator.  |       |
| 1    | <ul style="list-style-type: none"> <li>• PSS on.</li> <li>• Inject -2% voltage step into AVR voltage reference and hold at least for 10 seconds until stabilised</li> <li>• Remove step returning AVR Voltage Reference to nominal and hold for at least 10 seconds</li> </ul> |       |
|      | Under-excitation limit moved to normal position. Synchronous generator running at rated MW and at leading MVARs close to Under-excitation limit.   |       |
| 2    | <ul style="list-style-type: none"> <li>• PSS on.</li> <li>• Inject -2% voltage step into AVR voltage reference and hold at least for 10 seconds until stabilised</li> <li>• Remove step returning AVR Voltage Reference to nominal and hold for at least 10 seconds</li> </ul> |       |



OC5.A.2.6 Over-excitation Limiter Performance Test

Description & Purpose of Test

- OC5.A.2.6.1 The performance of the **Over-excitation Limiter**, where it exists, shall be demonstrated by testing its response to a step increase in the **Automatic Voltage Regulator** reference voltage that results in operation of the **Over-excitation Limiter**. Prior to application of the step the **Generating Unit** shall be generating **Rated Active Power** and operating within its continuous **Reactive Power** capability. The size of the step will be determined by the minimum value necessary to operate the **Over-excitation Limiter** and will be agreed by **NGET** and the **Generator**. The resulting operation beyond the **Over-excitation Limit** shall be controlled by the **Over-excitation Limiter** without the operation of any protection that could trip the **Generating Unit**. The step shall be removed immediately on completion of the test.
- OC5.A.2.6.2 If the **Over-excitation Limiter** has multiple levels to account for heating effects, an explanation of this functionality will be necessary and if appropriate, a description of how this can be tested.
- OC5.A.2.6.3 The following typical procedure is provided to assist **Generators** in drawing up their own site specific procedures for the **NGET** witnessed **Under-excitation Limiter** Tests.

| Test | Injection   | Notes |
|------|---|-------|
|      | Synchronous Generator running rated MW and maximum lagging MVAR.  |       |
|      | Over-excitation Limit temporarily set close to this operating point. PSS on.  |       |
| 1    | <ul style="list-style-type: none"> <li>• Inject positive voltage step into AVR voltage reference and hold</li> <li>• Wait till Over-excitation Limiter operates after sufficient time delay to bring back the excitation back to the limit.</li> <li>• Remove step returning AVR Voltage Reference to nominal.</li> </ul> |       |
|      | Over-excitation Limit restored to its normal operating value. PSS on.   |       |

OC5.A.2.7 Reactive Capability

- OC5.A.2.7.1 The leading and lagging **Reactive Power** capability on each **Generating Unit** will normally be demonstrated by operation of the **Generating Unit** at 0.85 power factor lagging for 1 hour and 0.95 power factor leading for 1 hour.
- OC5.A.2.7.2 In the case of an **Embedded Generating Unit** where distribution network considerations restrict the **Generating Unit Reactive Power** Output then the maximum leading and lagging capability will be demonstrated without breaching the host network operators limits.
- OC5.A.2.7.3 The test procedure, time and date will be agreed with **NGET** and will be to the instruction of **NGET** control centre and shall be monitored and recorded at both the **NGET** control centre and by the **Generator**.
- OC5.A.2.7.4 Where the **Generator** is recording the voltage and **Reactive Power** at the **Generating Unit** terminals the results shall be supplied in an electronic spreadsheet format.

OC5.A.2.8 Governor and Load Controller Response Performance

OC5.A.2.8.1 The governor and load controller response performance will be tested by injecting simulated frequency deviations into the governor and load controller systems. Such simulated frequency deviation signals must be injected simultaneously at both speed governor and load controller references. For **CCGT modules**, simultaneous injection into all gas turbines, steam turbine governors and module controllers is required.

OC5.A.2.8.2 Prior to witnessing the governor tests set out in OC5.A.2.8.6, **NGET** requires the **Generator** to conduct the preliminary tests detailed in OC5.A.2.8.4 and send the results to **NGET** for assessment unless agreed otherwise by **NGET**. The results should be supplied in an electronic spreadsheet format. These tests shall be completed at least two weeks prior to the witnessed governor response tests.

OC5.A.2.8.3 Where **CCGT module** or **Generating Unit** is capable of operating on alternative fuels, tests will be required to demonstrate performance when operating on each fuel. **NGET** may agree a reduction from the tests listed in OC5.A.2.8.6 for demonstrating performance on the alternative fuel. This includes the case where a main fuel is supplemented by bio-fuel.

Preliminary Governor Frequency Response Testing

OC5.A.2.8.4 Prior to conducting the full set of tests as per OC5.A.2.8.6, **Generators** are required to conduct a preliminary set of tests below to confirm the frequency injection method is correct and the plant control performance is within expectation. The test numbers refer to Figure 1 below. With the plant running at 80% of full load, the following frequency injections shall be applied.

| Test No (Figure 1) | Frequency Injection   | Notes |
|--------------------|---|-------|
| 8                  | <ul style="list-style-type: none"> <li>• Inject - 0.5Hz frequency fall over 10 sec</li> <li>• Hold until conditions stabilise</li> <li>• Remove the injected signal</li> </ul>  |       |
| 14                 | <ul style="list-style-type: none"> <li>• Inject +0.5Hz frequency rise over 10 sec</li> <li>• Hold until conditions stabilise</li> <li>• Remove the injected signal</li> </ul>   |       |
| 13                 | <ul style="list-style-type: none"> <li>• Inject -0.5Hz frequency fall over 10 sec</li> <li>• Hold for a further 20 sec</li> <li>• At 30 sec from the start of the test, Inject a +0.3Hz frequency rise over 30 sec.</li> <li>• Hold until conditions stabilise</li> <li>• Remove the injected signal</li> </ul> |       |

OC5.A.2.8.5 The recorded results (e.g. Finj, MW and control signals) should be sampled at a minimum rate of 1 Hz to allow **NGET** to assess the plant performance from the initial transients (seconds) to the final steady state conditions (5-15 minutes depending on the plant design). This is not witnessed by **NGET**. The Generator shall supply the recordings including data to **NGET** in an electronic spreadsheet format. Results shall be legible, identifiable by labelling, and shall have appropriate scaling.

Full Frequency Response Testing Schedule Witnessed by NGET

OC5.A.2.8.6 The tests are to be conducted at a number of different Module Load Points (MLP). The load points are conducted as shown below unless agreed otherwise by **NGET**.

|  |          |
|--|----------|
| Module Load Point 6<br><b>(Maximum Export Limit)</b>           | 100% MEL |
| Module Load Point 5  | 95% MEL  |
| Module Load Point 4<br>(Mid point of Operating Range)          | 80% MEL  |
| Module Load Point 3  | 70% MEL  |
| Module Load Point 2<br><b>(Minimum Generation)</b>             | MG       |
| Module Load Point 1<br><b>(Design Minimum Operating Level)</b> | DMOL     |

OC5.A.2.8.7 The tests are divided into the following two types;

- (i) **Frequency** response volume tests as per OC5.A.2.8. Figure 1. These tests consist of **Frequency** profile and ramp tests.
- (ii) **System** islanding and step response tests as shown by OC5.A.2.8. Figure 2.

OC5.A.2.8.8 There should be sufficient time allowed between tests for control systems to reach steady state. Where the diagram states 'HOLD' the current injection should be maintained until the **Active Power** (MW) output of the **Generating Unit or CCGT Module** has stabilised. The frequency response capability test (see Figure 1) injection signal shall be returned to zero at the same rate at which it was applied. **NGET** may require repeat tests should the tests give unexpected results.

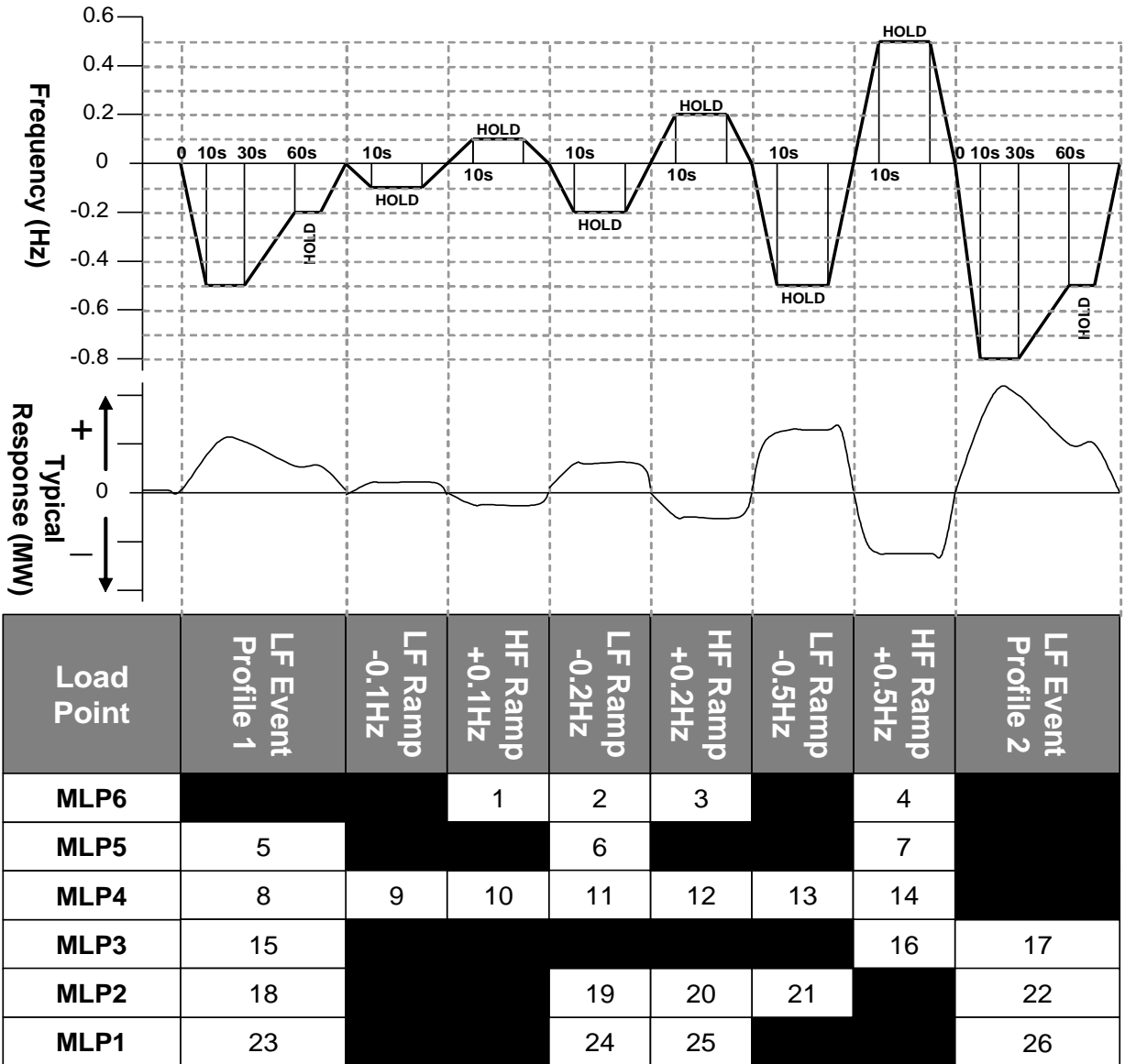

Figure 1: Frequency Response Capability Tests

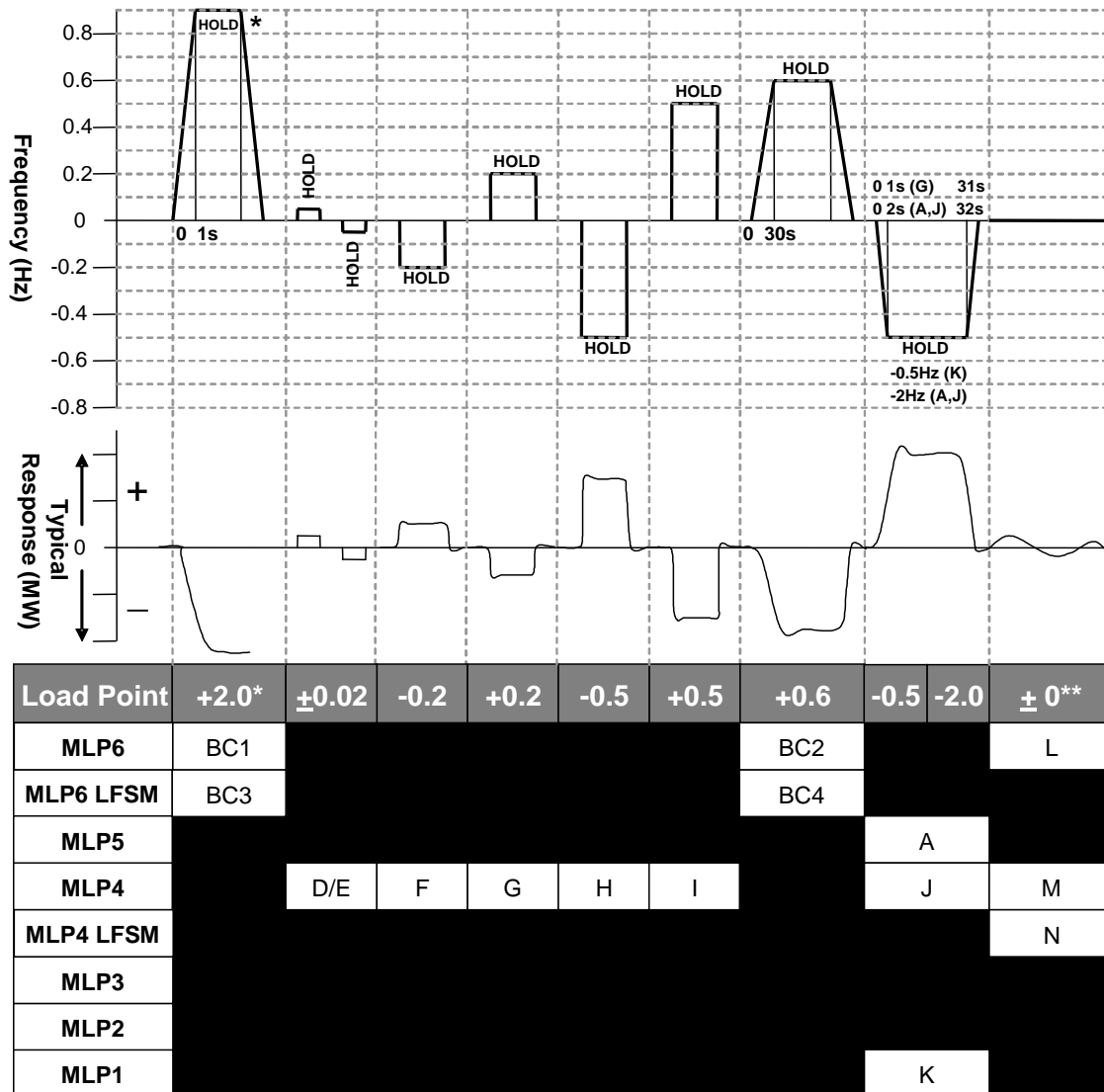

Figure 2: System islanding and step response tests

\* This will generally be +2.0Hz unless an injection of this size causes a reduction in plant output that takes the operating point below **Designed Minimum Operating Level** in which case an appropriate injection should be calculated in accordance with the following:

For example 0.9Hz is needed to take an initial output 65% to a final output of 20%. If the initial output was not 65% and the **Designed Minimum Operating Level** is not 20% then the injected step should be adjusted accordingly as shown in the example given below

|   |  |
|---|--|
| Initial Output                          | 65%  |
| <b>Designed Minimum Operating Level</b> | 20%  |
| Frequency Controller Droop              | 4%   |
| Frequency to be injected =              | $(0.65 - 0.20) \times 0.04 \times 50 = 0.9\text{Hz}$ |

\*\* Tests L and M in Figure 2 shall be conducted if in this range of tests the system frequency feedback signal is replaced by the injection signal rather than the injection signal being added to the system frequency signal. The tests will consist of monitoring the **Generating Unit and CCGT Module in Frequency Sensitive Mode** during normal system frequency variations without applying any injection. Test N in figure 2 shall be conducted in all cases. All three tests should be conducted for a period of at least 10 minutes.

OC5.A.2.9 Compliance with CC.6.3.3 Functionality Test

- OC5.A.2.9.1 Where the plant design includes active control function or functions to deliver CC.6.3.3 compliance, the **Generator** will propose and agree a test procedure with **NGET**, which will demonstrate how the **Generating Unit Active Power** output responds to changes in **System Frequency** and ambient conditions (e.g. by **Frequency** and temperature injection methods).
- OC5.A.2.9.2 The **Generator** shall inform **NGET** if any load limiter control is additionally employed.
- OC5.A.2.9.3 With reference to the signals specified in OC5.A.1, **NGET** will agree with the **Generator** which additional control system parameters shall be monitored to demonstrate the functionality of CC.6.3.3 compliance systems. Where **NGET** recording equipment is not used results shall be supplied to **NGET** in an electronic spreadsheet format.

## APPENDIX 3 - COMPLIANCE TESTING OF POWER PARK MODULES (AND OTSUA)

### OC5.A.3.1 Scope

OC5.A.3.1.1 This Appendix outlines the general testing requirements for **Power Park Modules** and OTSUA to demonstrate compliance with the relevant aspects of the **Grid Code, Ancillary Services Agreement** and **Bilateral Agreement**. The tests specified in this Appendix will normally be sufficient to demonstrate compliance however **NGET** may:

- (i) agree an alternative set of tests provided **NGET** deem the alternative set of tests sufficient to demonstrate compliance with the **Grid Code, Ancillary Services Agreement** and **Bilateral Agreement**; and/or
- (ii) require additional or alternative tests if information supplied to **NGET** during the compliance process suggests that the tests in this Appendix will not fully demonstrate compliance with the relevant section of the **Grid Code, Ancillary Services Agreement** or **Bilateral Agreement**; and/or
- (iii) require additional tests if a **Power System Stabiliser** is fitted; and/or
- (iv) agree a reduced set of tests if a relevant **Manufacturer's Data & Performance Report** has been submitted to and deemed to be appropriate by **NGET**; and/or
- (v) agree a reduced set of tests for subsequent **Power Park Modules** or OTSUA following successful completion of the first **Power Park Module** or OTSUA tests in the case of a **Power Station** comprised of two or more **Power Park Modules** or OTSUA which **NGET** reasonably considers to be identical.

If:

- (a) the tests performed pursuant to OC5.A.3.1.1(iv) do not replicate the results contained in the **Manufacturer's Data & Performance Report** or
- (b) the tests performed pursuant to OC5.A.3.1.1(v) in respect of subsequent **Power Park Modules** or OTSUA do not replicate the full tests for the first **Power Park Module** or OTSUA, or
- (c) any of the tests performed pursuant to OC5.A.3.1.1(iv) or OC5.A.3.1.1(v) do not fully demonstrate compliance with the relevant aspects of the **Grid Code, Ancillary Services Agreement** and / or **Bilateral Agreement**,

then notwithstanding the provisions above, the full testing requirements set out in this Appendix will be applied.

OC5.A.3.1.2 The **Generator** is responsible for carrying out the tests set out in and in accordance with this Appendix and the **Generator** retains the responsibility for the safety of personnel and plant during the test. **NGET** will witness all of the tests outlined or agreed in relation to this Appendix unless **NGET** decides and notifies the **Generator** owner otherwise. Reactive Capability tests may be witnessed by **NGET** remotely from the **NGET** control centre. For all on site **NGET** witnessed tests the **Generator** must ensure suitable representatives from the **Generator** and / or **Power Park Module** manufacturer (if appropriate) and/or OTSUA manufacturer (if appropriate) are available on site for the entire testing period. In all cases and in addition to any recording of signals conducted by **NGET** the **Generator** shall record all relevant test signals as outlined in OC5.A.1.

OC5.A.3.1.3 In addition to the dynamic signals supplied in OC5.A.1 the **Generator** shall inform **NGET** of the following information prior to the commencement of the tests and any changes to the following, if any values change during the tests:

- (i) All relevant transformer tap numbers; and
- (ii) Number of **Power Park Units** in operation

OC5.A.3.1.4 The **Generator** shall submit a detailed schedule of tests to **NGET** in accordance with CP.6.3.1, and this Appendix.

- OC5.A.3.1.5 Prior to the testing of a **Power Park Module** or OTSUA the **Generator** shall complete the **Integral Equipment Tests** procedure in accordance with OC.7.5.
- OC5.A.3.1.6 Partial **Power Park Module** or OTSUA testing as defined in OC5.A.3.2 and OC5.A.3.3 is to be completed at the appropriate stage in accordance with CP.6.
- OC5.A.3.1.7 Full **Power Park Module** or OTSUA testing as required by CP.7.2 is to be completed as defined in OC5.A.3.4 through to OC5.A.3.7.
- OC5.A.3.1.8 Where **OTSDUW Arrangements** apply and prior to the **OTSUA Transfer Time** any relevant **OTSDUW Plant and Apparatus** shall be considered within the scope of testing ~~of a Power Park Module~~ described in this Appendix. Performance shall be assessed against the relevant Grid Code requirements for **OTSDUW Plant and Apparatus** at the **Interface Point** and other **Generator Plant and Apparatus** at the **Offshore Grid Entry Point**. This Appendix should be read accordingly.
- OC5.A.3.2 Pre 20% (or <50MW) **Synchronised Power Park Module** Basic Voltage Control Tests
- OC5.A.3.2.1 Before 20% of the **Power Park Module** (or 50MW if less) has commissioned, either voltage control test OC5.A.3.5.6(i) or (ii) must be completed in accordance with CP.6.
- OC5.A.3.2.2 In the case of an **Offshore Power Park Module** which provides all or a portion of the **Reactive Power** capability as described in CC.6.3.2(e)(iii) and / or voltage control requirements as described in CC.6.3.8(b)(ii) to enable an **Offshore Transmission Licensee** to meet the requirements of **STC** Section K, the **Generator** is required to cooperate with the **Offshore Transmission Licensee** to conduct the 20% voltage control test. The results in relation to the **Offshore Power Park Module** will be assessed against the requirements in the **Bilateral Agreement**. In the case of OTSUA prior to the OTSUA Transfer Time, the Generator shall conduct the testing by reference to the entire control system responding to changes at the Interface Point.
- OC5.A.3.3 For **Power Park Modules** with **Registered Capacity**  $\geq 100\text{MW}$  Pre 70% **Power Park Module** Tests
- OC5.A.3.3.1 Before 70% but with at least 50% of the **Power Park Module** commissioned the following **Limited Frequency Sensitive** tests as detailed in OC5.A.3.6.2 must be completed.
- (a) BC3
- (b) BC4
- OC5.A.3.4 Reactive Capability Test
- OC5.A.3.4.1 This section details the procedure for demonstrating the reactive capability of an **Onshore Power Park Module** or an **Offshore Power Park Module** or OTSUA which provides all or a portion of the **Reactive Power** capability as described in CC.6.3.2(e)(iii) (for the avoidance of doubt, an **Offshore Power Park Module** which does not provide part of the **Offshore Transmission Licensee Reactive Power** capability as described in CC6.3.2(e)(i) and CC6.3.2(e)(ii) should complete the reactive power transfer / voltage control tests as per section OC5.A.3.8). These tests should be scheduled at a time where there are at least 95% of the **Power Park Units** within the **Power Park Module** in service. There should be sufficient MW resource forecasted in order to generate at least 85% of **Registered Capacity** of the **Power Park Module**.
- OC5.A.3.4.2 The tests shall be performed by modifying the voltage set-point of the voltage control scheme of the **Power Park Module** or OTSUA by the amount necessary to demonstrate the required reactive range. This is to be conducted for the operating points and durations specified in OC5.A.3.4.5.
- OC5.A.3.4.3 **Embedded Generator** should liaise with the relevant **Network Operator** to ensure the following tests will not have an adverse impact upon the **Network Operator's System** as per OC.7.5. In situations where the tests have an adverse impact upon the **Network Operator's System** **NET** will only require demonstration within the acceptable limits of the **Network Operator**. For the avoidance of doubt, these tests do not negate the requirement to produce a complete **Power Park Module** performance chart as specified in OC2.4.2.1



- OC5.A.3.4.4 In the case where the **Reactive Power** metering point is not at the same location as the **Reactive Power** capability requirement, then an equivalent **Reactive Power** capability for the metering point shall be agreed between the **Generator** and **NGET**.
- OC5.A.3.4.5 The following tests shall be completed:
- (i) Operation in excess of 50% **Rated MW** and maximum continuous lagging **Reactive Power** for 60 minutes.
  - (ii) Operation in excess of 50% **Rated MW** and maximum continuous leading **Reactive Power** for 60 minutes.
  - (iii) Operation at 50% **Rated MW** and maximum continuous leading **Reactive Power** for 5 minutes.
  - (iv) Operation at 20% **Rated MW** and maximum continuous leading **Reactive Power** for 5 minutes.
  - (v) Operation at 20% **Rated MW** and maximum continuous lagging **Reactive Power** for 5 minutes.
  - (vi) Operation at less than 20% **Rated MW** and unity **Power Factor** for 5 minutes. This test only applies to systems which do not offer voltage control below 20% of **Rated MW**.
  - (vii) Operation at 0% **Rated MW** and maximum continuous leading **Reactive Power** for 5 minutes. This test only applies to systems which offer voltage control below 20% and hence establishes actual capability rather than required capability.
  - (viii) Operation at 0% **Rated MW** and maximum continuous lagging **Reactive Power** for 5 minutes. This test only applies to systems which offer voltage control below 20% and hence establishes actual capability rather than required capability.
- OC5.A.3.4.6 Within this OC lagging **Reactive Power** is the export of **Reactive Power** from the **Power Park Module** to the **Total System** and leading **Reactive Power** is the import of **Reactive Power** from the **Total System** to the **Power Park Module** or OTSUA.
- OC5.A.3.4.7 Where the **Generator** provides a report from a **Power Park Unit** manufacturer validating the full **Reactive Power** capability envelope of the **Power Park Unit** by test results acceptable to **NGET**, **NGET** may agree a reduction from the set of tests detailed in OC5.A.3.4.5. The validation testing detailed in the report must fully demonstrate the **Reactive Power** capability across both the **Active Power** range and the range of unit terminal voltages.
- OC5.A.3.5 Voltage Control Tests
- OC5.A.3.5.1 This section details the procedure for conducting voltage control tests on **Onshore Power Park Modules** or OTSUA or an **Offshore Power Park Module** which provides all or a portion of the voltage control capability as described in CC.6.3.8(b)(ii) (for the avoidance of doubt, **Offshore Power Park Modules** which do not provide part of the **Offshore Transmission Licensee** voltage control capability as described in CC6.3.8(b)(i) should complete the reactive power transfer / voltage control tests as per section OC5.A.3.8). These tests should be scheduled at a time when there are at least 95% of the **Power Park Units** within the **Power Park Module** in service. There should be sufficient MW resource forecasted in order to generate at least 65% of **Registered Capacity** of the **Onshore Power Park Module**. An **Embedded Generator** should also liaise with the relevant **Network Operator** to ensure all requirements covered in this section will not have a detrimental effect on the **Network Operator's System**.
- OC5.A.3.5.2 The voltage control system shall be perturbed with a series of step injections to the **Power Park Module** voltage reference, and where possible, multiple up-stream transformer taps. In the case of an **Offshore Power Park Module** providing part of the **Offshore Transmission Licensee** voltage control capability this may require a series of step injections to the voltage reference of the **Offshore Transmission Licensee** control system.
- OC5.A.3.5.3 For steps initiated using network tap changers the **Generator** will need to coordinate with **NGET** or the relevant **Network Operator** as appropriate. The time between transformer taps shall be at least 10 seconds as per OC5.A.3.5 Figure 1.

- OC5.A.3.5.4 For step injection into the **Power Park Module** or **OTSUA** voltage reference, steps of  $\pm 1\%$  and  $\pm 2\%$  shall be applied to the voltage control system reference summing junction. The injection shall be maintained for 10 seconds as per OC5.A.3.5 Figure 2.
- OC5.A.3.5.5 Where the voltage control system comprises of discretely switched plant and apparatus additional tests will be required to demonstrate that its performance is in accordance with Grid Code and **Bilateral Agreement** requirements.
- OC5.A.3.5.6 Tests to be completed:
  - (i)

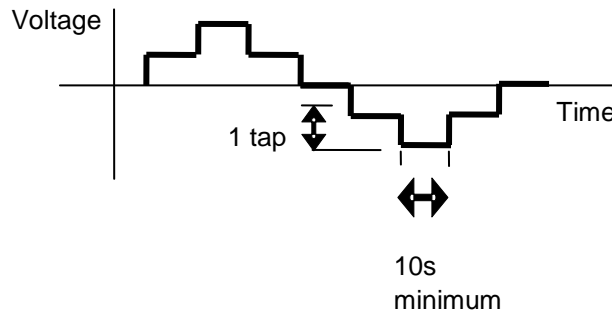

OC5.A.3.5 Figure 1 – Transformer tap sequence for voltage control tests

(ii)

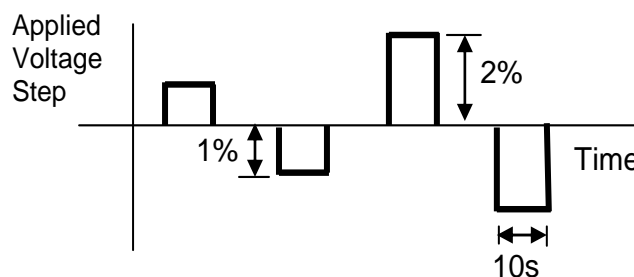

OC5.A.3.5 Figure 2 – Step injection sequence for voltage control tests

**OC.A.3.5.7** In the case of **OTSUA** where the **Bilateral Agreement** specifies additional damping facilities, additional testing to demonstrate these damping facilities may be required.

**OC5.A.3.6** Frequency Response Tests

- OC5.A.3.6.1 This section describes the procedure for performing frequency response testing on an **Power Park Module**. These tests should be scheduled at a time where there are at least 95% of the **Power Park Units** within the **Power Park Module** in service. There should be sufficient MW resource forecasted in order to generate at least 65% of **Registered Capacity** of the **Power Park Module**.
- OC5.A.3.6.2 The frequency controller shall be in **Frequency Sensitive Mode** or **Limited Frequency Sensitive Mode** as appropriate for each test. Simulated frequency deviation signals shall be injected into the frequency controller reference/feedback summing junction. If the injected frequency signal replaces rather than sums with the real system frequency signal then the additional tests outlined in OC5.A.3.6.6 shall be performed with the **Power Park Module** or **Power Park Unit** in normal **Frequency Sensitive Mode** monitoring actual system frequency, over a period of at least 10 minutes. The aim of this additional test is to verify that the control system correctly measures the real system frequency for normal variations over a period of time.

OC5.A.3.6.3 In addition to the frequency response requirements it is necessary to demonstrate the **Power Park Module** ability to deliver a requested steady state power output which is not impacted by power source variation as per CC.6.3.9. This test shall be conducted in **Limited Frequency Sensitive Mode** at a part-loaded output for a period of 10 minutes as per OC5.A.3.6.6.

Preliminary Frequency Response Testing

OC5.A.3.6.4 Prior to conducting the full set of tests as per OC5.A.3.6.6, **Generators** are required to conduct the preliminary set of tests below to confirm the frequency injection method is correct and the plant control performance is within expectation. The test numbers refer to Figure 1 below. The test should be conducted when sufficient MW resource is forecasted in order to generate at least 65% of **Registered Capacity** of the **Power Park Module**. The following frequency injections shall be applied when operating at module load point 4.

| Test No<br>(Figure 1) | Frequency Injection   | Notes |
|-----------------------|---|-------|
| 8                     | <ul style="list-style-type: none"> <li>Inject - 0.5Hz frequency fall over 10 sec</li> <li>Hold until conditions stabilise</li> <li>Remove the injected signal</li> </ul>  |       |
| 14                    | <ul style="list-style-type: none"> <li>Inject +0.5Hz frequency rise over 10 sec</li> <li>Hold until conditions stabilise</li> <li>Remove the injected signal</li> </ul>   |       |
| 13                    | <ul style="list-style-type: none"> <li>Inject -0.5Hz frequency fall over 10 sec</li> <li>Hold for a further 20 sec</li> <li>At 30 sec from the start of the test, Inject a +0.3Hz frequency rise over 30 sec.</li> <li>Hold until conditions stabilise</li> <li>Remove the injected signal</li> </ul> |       |

OC5.A.3.6.5 The recorded results (e.g. Finj, MW and control signals) should be sampled at a minimum rate of 1 Hz to allow **NGET** to assess the plant performance from the initial transients (seconds) to the final steady state conditions (5-15 minutes depending on the plant design). This is not witnessed by **NGET**. The **Generator** shall supply the recordings including data to **NGET** in an electronic spreadsheet format. Results shall be legible, identifiable by labelling, and shall have appropriate scaling.

Full Frequency Response Testing Schedule Witnessed by NGET

OC5.A.3.6.6 The tests are to be conducted at a number of different Module Load Points (MLP). In the case of a **Power Park Module** the module load points are conducted as shown below unless agreed otherwise by **NGET**.

|  |            |
|--|------------|
| Module Load Point 6<br>( <b>Maximum Export Limit</b> )           | 100% MEL   |
| Module Load Point 5  | 90% MEL    |
| Module Load Point 4<br>(Mid point of Operating Range)            | 80% MEL    |
| Module Load Point 3  | DMOL + 20% |
| Module Load Point 2  | DMOL + 10% |
| Module Load Point 1<br>( <b>Design Minimum Operating Level</b> ) | DMOL       |

OC5.A.3.6.7 The tests are divided into the following two types;

- (i) Frequency response volume tests as per OC5.A.3.6. Figure 1. These tests consist of frequency profile and ramp tests.
- (ii) System islanding and step response tests as shown by OC5.A.3.6 Figure 2

OC5.A.3.6.8 There should be sufficient time allowed between tests for control systems to reach steady state (depending on available power resource). Where the diagram states 'HOLD' the current injection should be maintained until the **Active Power** (MW) output of the **Power Park Module** has stabilised. All frequency response tests should be removed over the same timescale for which they were applied. **NGET** may require repeat tests should the response volume be affected by the available power, or if tests give unexpected results.

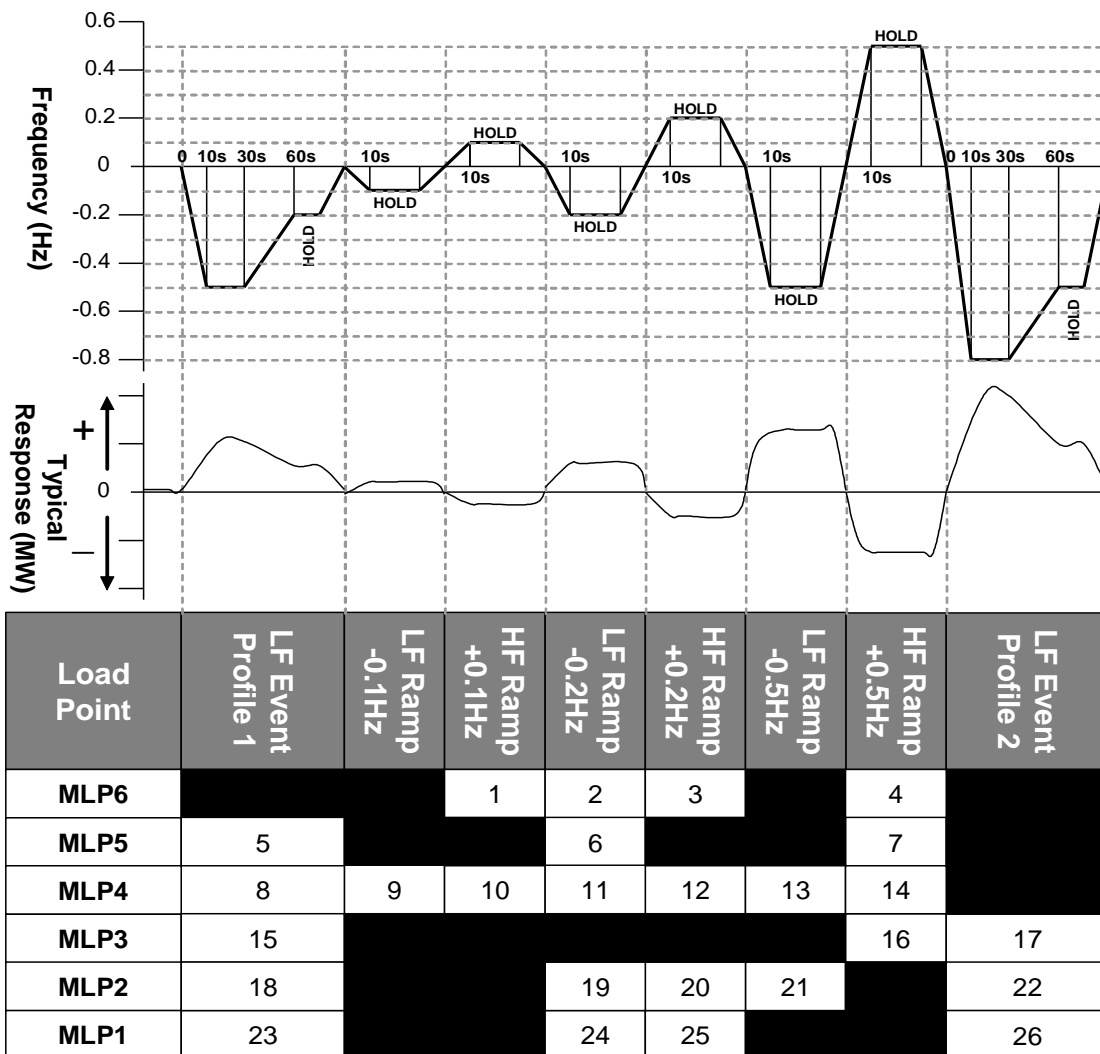

OC5.A.3.6. Figure 1 – Frequency response volume tests

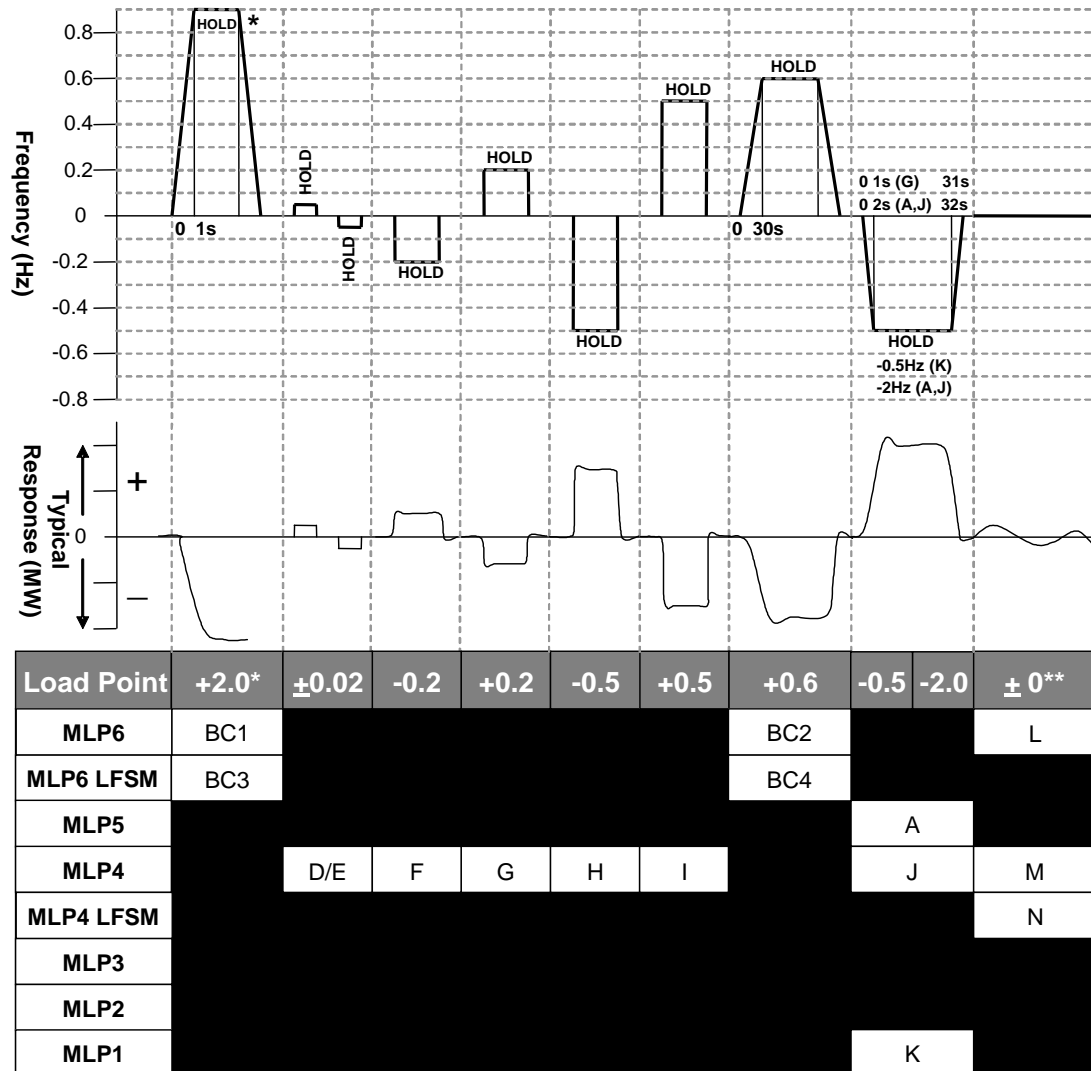

OC5.A.3.6. Figure 2 – System islanding and step response tests

\* This will generally be +2.0Hz unless an injection of this size causes a reduction in plant output that takes the operating point below **Designed Minimum Operating Level** in which case an appropriate injection should be calculated in accordance with the following:

For example 0.9Hz is needed to take an initial output 65% to a final output of 20%. If the initial output was not 65% and the **Designed Minimum Operating Level** is not 20% then the injected step should be adjusted accordingly as shown in the example given below

|   |  |
|---|--|
| Initial Output                          | 65%  |
| <b>Designed Minimum Operating Level</b> | 20%  |
| Frequency Controller Droop              | 4%   |
| Frequency to be injected =              | $(0.65 - 0.20) \times 0.04 \times 50 = 0.9\text{Hz}$ |

\*\* Tests L and M in Figure 2 shall be conducted if in this range of tests the system frequency feedback signal is replaced by the injection signal rather than the injection signal being added to the system frequency signal. The tests will consist of monitoring the **Power Park Module** in **Frequency Sensitive Mode** during normal system frequency variations without applying any injection. Test N in Figure 2 shall be conducted in all cases. All three tests should be conducted for a period of at least 10 minutes.

#### OC5.A.3.7 Fault Ride Through Testing

OC5.A.3.7.1 This section describes the procedure for conducting fault ride through tests on a single **Power Park Unit**.

OC5.A.3.7.2 The test circuit will utilise the full **Power Park Unit** with no exclusions (e.g. in the case of a wind turbine it would include the full wind turbine structure) and shall be conducted with sufficient resource available to produce at least 95% of the **Registered Capacity** of the **Power Park Unit**. The test will comprise of a number of controlled short circuits applied to a test network to which the **Power Park Unit** is connected, typically comprising of the **Power Park Unit** transformer and a test impedance to shield the connected network from voltage dips at the **Power Park Unit** terminals.

OC5.A.3.7.3 In each case the tests should demonstrate the minimum voltage at the **Power Park Unit** terminals or **High Voltage** side of the **Power Park Unit** transformer which the **Power Park Unit** can withstand for the length of time specified in OC5.A.3.7.5. Any test results provided to **NGET** should contain sufficient data pre and post fault in order to determine steady state values of all signals, and the power recovery timescales.

OC5.A.3.7.4 In addition to the signals outlined in OC5.A.1.2. the following signals from either the **Power Park Unit** terminals or **High Voltage** side of the **Power Park Unit** transformer should be provided for this test only:

- (i) Phase voltages
- (ii) Positive phase sequence and negative phase sequence voltages
- (iii) Phase currents
- (iv) Positive phase sequence and negative phase sequence currents
- (v) Estimate of **Power Park Unit** negative phase sequence impedance
- (vi) MW – **Active Power** at the generating unit.
- (vii) MVA<sub>r</sub> – **Reactive Power** at the generating unit.
- (viii) Mechanical Rotor Speed
- (ix) Real / reactive, current / power reference as appropriate
- (x) Fault ride through protection operation (e.g. a crowbar in the case of a doubly fed induction generator)
- (xi) Any other signals relevant to the control action of the fault ride through control deemed applicable for model validation.

At a suitable frequency rate for fault ride through tests as agreed with **NGET**.

OC5.A.3.7.5 The tests should be conducted for the times and fault types indicated in OC5.A.3.7 Table 1.

| 3 Phase | Phase to Phase | 2 Phase to Earth | 1 Phase to Earth | Grid Code Ref |
|---------|----------------|------------------|------------------|---------------|
| 0.14s   | 0.14s          | 0.14s            | 0.14s            | CC.6.3.15a    |
| 0.384s  |                |                  |                  | CC.6.3.15b    |
| 0.710s  |                |                  |                  |               |
| 2.5s    |                |                  |                  |               |
| 180.0s  |                |                  |                  |               |

OC5.A.3.7 Table 1 – Types of fault for fault ride through **testing**

OC5.A.3.8 Reactive Power Transfer / Voltage Control Tests for Offshore Power Park Modules

- OC5.A.3.8.1 In the case of an **Offshore Power Park Module** which provides all or a portion of the **Reactive Power** capability as described in CC.6.3.2(e)(iii) and / or voltage control requirements as described in CC.6.3.8(b)(ii) to enable an **Offshore Transmission Licensee** to meet the requirements of STC Section K, the testing, will comprise of the entire control system responding to changes at the onshore **Interface Point**. Therefore the tests in this section OC5.A.3.8 will not apply. The **Generator** shall cooperate with the relevant **Offshore Transmission Licensee** to facilitate these tests as required by **NGET**. The testing may be combined with testing of the corresponding **Offshore Transmission Licensee** requirements under the STC. The results in relation to the **Offshore Power Park Module** will be assessed against the requirements in the **Bilateral Agreement**.
- OC5.A.3.8.2 In the case of an **Offshore Power Park Module** which does not provide part of the **Offshore Transmission Licensee Reactive Power** capability the following procedure for conducting reactive power transfer control tests on **Offshore Power Park Modules** and / or voltage control system as per CC6.3.2(e)(i) and CC6.3.2(e)(ii) apply. These tests should be carried out prior to 20% of the **Power Park Units** within the **Offshore Power Park Module** being synchronised, and again when at least 95% of the **Power Park Units** within the **Offshore Power Park Module** in service. There should be sufficient power resource forecast to generate at least 85% of the **Registered Capacity** of the **Offshore Power Park Module**.
- OC5.A.3.8.3 The **Reactive Power** control system shall be perturbed by a series of system voltage changes and changes to the **Active Power** output of the **Offshore Power Park Module**.
- OC5.A.3.8.4 System voltage changes should be created by a series of multiple upstream transformer taps. The **Generator** should coordinate with **NGET** or the relevant **Network Operator** in order to conduct the required tests. The time between transformer taps should be at least 10 seconds as per OC5.A.3.8 Figure 1.
- OC5.A.3.8.5 The active power output of the **Offshore Power Park Module** should be varied by applying a sufficiently large step to the frequency controller reference/feedback summing junction to cause a 10% change in output of the **Registered Capacity** of the **Offshore Power Park Module** in a time not exceeding 10 seconds. This test does not need to be conducted provided that the frequency response tests as outlined in OC5.A.3.6 are completed.
- OC5.A.3.8.6 The following diagrams illustrate the tests to be completed:

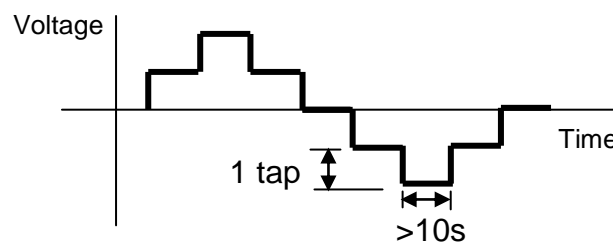

OC5.A.3.8 Figure 1 – Transformer tap sequence for reactive transfer tests

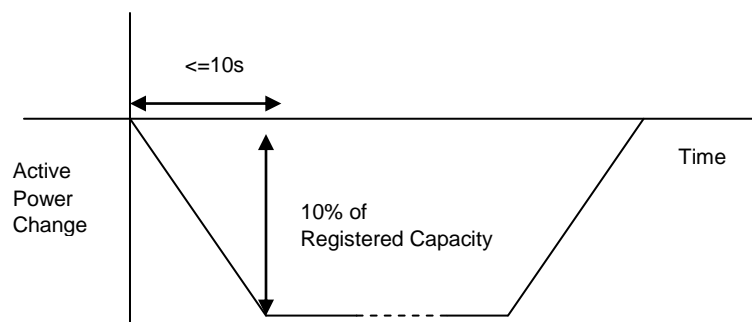

OC5.A.3.8 Figure 2 – Active Power ramp for reactive transfer tests



## APPENDIX 4 - COMPLIANCE TESTING FOR DC CONVERTERS AT A DC CONVERTER STATION

### OC5.A.4.1 Scope

OC5.A.4.1.1 This Appendix outlines the general testing requirements for **DC Converter Station** owners to demonstrate compliance with the relevant aspects of the **Grid Code**, **Ancillary Services Agreement** and **Bilateral Agreement**. The tests specified in this Appendix will normally be sufficient to demonstrate compliance however **NGET** may:

- (i) agree an alternative set of tests provided **NGET** deem the alternative set of tests sufficient to demonstrate compliance with the **Grid Code**, **Ancillary Services Agreement** and **Bilateral Agreement**; and/or
- (ii) require additional or alternative tests if information supplied to **NGET** during the compliance process suggests that the tests in this Appendix will not fully demonstrate compliance with the relevant section of the **Grid Code**, **Ancillary Services Agreement** or **Bilateral Agreement**; and/or
- (iii) require additional tests if control functions to improve damping of power system oscillations and/or subsynchronous resonance torsional oscillations required by the **Bilateral Agreement** or included in the control scheme and active; and/or
- (iv) agree a reduced set of tests for subsequent **DC Converters** following successful completion of the first **DC Converter** tests in the case of a **Power Station** comprised of two or more **DC Converters** which **NGET** reasonably considers to be identical.

If:

- (a) the tests performed pursuant to OC5.A.4.1.1(iv) in respect of subsequent **DC Converters** do not replicate the full tests for the first **DC Converter**, or
- (b) any of the tests performed pursuant to OC5.A.4.1.1(iv) do not fully demonstrate compliance with the relevant aspects of the **Grid Code**, **Ancillary Services Agreement** and / or **Bilateral Agreement**,

then notwithstanding the provisions above, the full testing requirements set out in this Appendix will be applied.

OC5.A.4.1.2 The **DC Converter Station** owner is responsible for carrying out the tests set out in and in accordance with this Appendix and the **DC Converter Station** owner retains the responsibility for the safety of personnel and plant during the test. The **DC Converter Station** owner is responsible for ensuring that suitable arrangements are in place with the **Externally Interconnected System Operator** to facilitate testing. **NGET** will witness all of the tests outlined or agreed in relation to this Appendix unless **NGET** decides and notifies the **DC Converter Station** owner otherwise. Reactive Capability tests if required, may be witnessed by **NGET** remotely from the **NGET** control centre. For all on site **NGET** witnessed tests the **DC Converter Station** owner must ensure suitable representatives from the **DC Converter Station** owner and / or **DC Converter** manufacturer (if appropriate) are available on site for the entire testing period. In all cases and in addition to any recording of signals conducted by **NGET** the **DC Converter Station** owner shall record all relevant test signals as outlined in OC5.A.1.

OC5.A.4.1.3 In addition to the dynamic signals supplied in OC5.A.1 the **DC Converter Station** owner shall inform **NGET** of the following information prior to the commencement of the tests and any changes to the following, if any values change during the tests:

- (i) All relevant transformer tap numbers.

OC5.A.4.1.4 The **DC Converter Station** owner shall submit a detailed schedule of tests to **NGET** in accordance with CP.6.3.1, and this Appendix.

OC5.A.4.1.5 Prior to the testing of a **DC Converter** the **DC Converter Station** owner shall complete the **Integral Equipment Tests** procedure in accordance with OC.7.5

- OC5.A.4.1.6 Full **DC Converter** testing as required by CP.7.2 is to be completed as defined in OC5.A.4.2 through to OC5.A.4.5
- OC5.A.4.2 Reactive Capability Test
- OC5.A.4.2.1 This section details the procedure for demonstrating the reactive capability of an **Onshore DC Converter**. These tests should be scheduled at a time where there are sufficient MW resource forecasted in order to import and export full **Registered Capacity** of the **DC Converter**.
- OC5.A.4.2.2 The tests shall be performed by modifying the voltage set-point of the voltage control scheme of the **DC Converter** by the amount necessary to demonstrate the required reactive range. This is to be conducted for the operating points and durations specified in OC5.A.4.2.5.
- OC5.A.4.2.3 **Embedded DC Converter Station** owner should liaise with the relevant **Network Operator** to ensure the following tests will not have an adverse impact upon the **Network Operator's System** as per OC.7.5. In situations where the tests have an adverse impact upon the **Network Operator's System** **NET** will only require demonstration within the acceptable limits of the **Network Operator**. For the avoidance of doubt, these tests do not negate the requirement to produce a complete **DC Converter** performance chart as specified in OC2.4.2.1.
- OC5.A.4.2.4 In the case where the **Reactive Power** metering point is not at the same location as the **Reactive Power** capability requirement, then an equivalent **Reactive Power** capability for the metering point shall be agreed between the **DC Converter Station** owner and **NET**.
- OC5.A.4.2.5 The following tests shall be completed for both importing and exporting of Active Power for a **DC Converter** (excluding current source technology):
- (i) Operation at **Rated MW** and maximum continuous lagging **Reactive Power** for 60 minutes.
  - (ii) Operation at **Rated MW** and maximum continuous leading **Reactive Power** for 60 minutes.
  - (iii) Operation at 50% **Rated MW** and maximum continuous leading **Reactive Power** for 5 minutes.
  - (iv) Operation at 20% **Rated MW** and maximum continuous leading **Reactive Power** for 5 minutes.
  - (v) Operation at 20% **Rated MW** and maximum continuous lagging **Reactive Power** for 5 minutes.
  - (vi) Operation at less than 20% **Rated MW** and unity **Power Factor** for 5 minutes. This test only applies to systems which do not offer voltage control below 20% of **Rated MW**.
  - (vii) Operation at 0% **Rated MW** and maximum continuous leading **Reactive Power** for 5 minutes. This test only applies to systems which offer voltage control below 20% and hence establishes actual capability rather than required capability.
  - (viii) Operation at 0% **Rated MW** and maximum continuous lagging **Reactive Power** for 5 minutes. This test only applies to systems which offer voltage control below 20% and hence establishes actual capability rather than required capability.
- OC5.A.4.2.6 For the avoidance of doubt, lagging **Reactive Power** is the export of **Reactive Power** from the **DC Converter** to the **Total System** and leading **Reactive Power** is the import of **Reactive Power** from the **Total System** to the **DC Converter**.

OC5.A.4.3 Reactive Control Testing For DC Converters (Current Source Technology)

OC5.A.4.3.1 The Reactive control testing for **DC Converters** employing current source technology shall be for both importing and exporting of Active Power and shall demonstrate that the reactive power transfer limits specified in the **Bilateral Agreement** are not exceeded. The **Reactive Power** control system shall be perturbed by a series of system voltage changes to the **Active Power** output of the **DC Converter** and changes of system voltage where possible. The **DC Converter Station** owner is responsible for ensuring that suitable arrangements are in place with the **Externally Interconnected System Operator** to facilitate the active power changes required by these tests

OC5.A.4.3.2 The active power output of the **DC Converter** should be varied by applying a sufficiently large step to the frequency controller reference/feedback summing junction to cause at least a 10% change in output of the **Registered Capacity** of the **DC Converter** in a time not exceeding 10 seconds. This test does not need to be conducted provided that the frequency response tests as outlined in OC5.A.4.3 are completed.

OC5.A.4.3.3 Where possible system voltage changes should be created by a series of multiple upstream transformer taps. The **DC Converter station** owner should coordinate with **NGET** or the relevant **Network Operator** in order to conduct the required tests. The time between transformer taps should be at least 10 seconds as per OC5.A.4.3 Figure 1.

OC5.A.4.3.4 The following diagrams illustrate the tests to be completed:

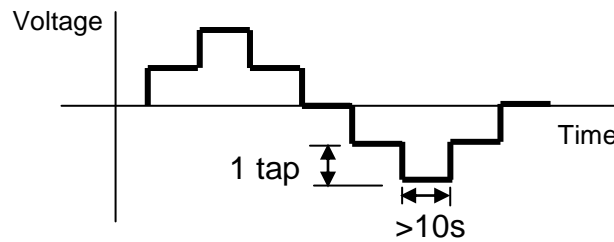

OC5.A.4.3 Figure 1 – Transformer tap sequence for reactive transfer tests

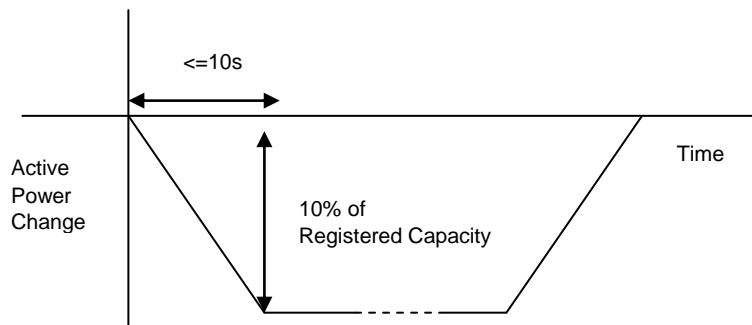

OC5.A.4.3 Figure 2 – Active Power ramp for reactive transfer tests

OC5.A.4.4 Voltage Control Tests

OC5.A.4.4.1 This section details the procedure for conducting voltage control tests on **DC Converters** (excluding current source technology). These tests should be scheduled at a time where there are sufficient MW resource in order to import and export full **Registered Capacity** of the **DC Converter**. An **Embedded DC Converter Station** owner should also liaise with the relevant **Network Operator** to ensure all requirements covered in this section will not have a detrimental effect on the **Network Operator's System**.

OC5.A.4.4.2 The voltage control system shall be perturbed with a series of step injections to the **DC Converter** voltage reference, and where possible, multiple up-stream transformer taps.

OC5.A.4.4.3 For steps initiated using network tap changers the **DC Converter Station** owner will need to coordinate with **NGET** or the relevant **Network Operator** as appropriate. The time between transformer taps shall be at least 10 seconds as per OC5.A.4.4 Figure 1.

- OC5.A.4.4.4 For step injection into the **DC Converter** voltage reference, steps of  $\pm 1\%$  and  $\pm 2\%$  shall be applied to the voltage control system reference summing junction. The injection shall be maintained for 10 seconds as per OC5.A.4.4 Figure 2.
- OC5.A.4.4.5 Where the voltage control system comprises of discretely switched plant and apparatus additional tests will be required to demonstrate that its performance is in accordance with **Grid Code** and **Bilateral Agreement** requirements.
- OC5.A.4.4.6 Tests to be completed:
- (i)

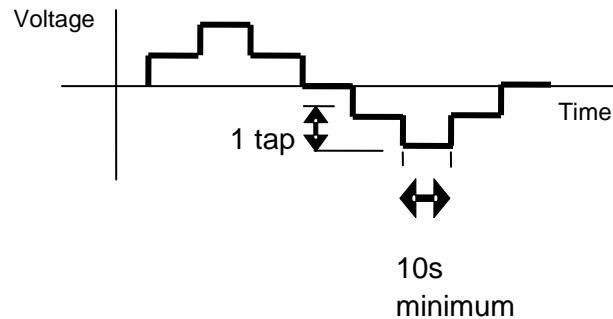

OC5.A.4.4 Figure 1 – Transformer tap sequence for voltage control tests

(ii)

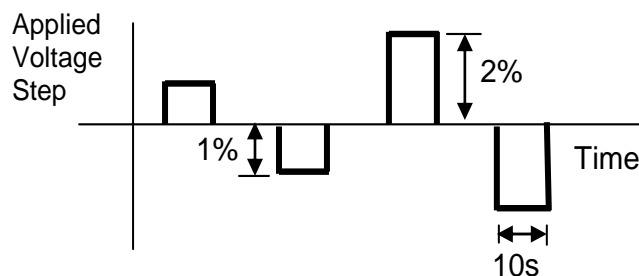

OC5.A.4.4 Figure 2 – Step injection sequence for voltage control tests

- OC5.A.4.5 Frequency Response Tests
- OC5.A.4.5.1 This section describes the procedure for performing frequency response testing on a **DC Converter**. These tests should be scheduled at a time where there are sufficient MW resource in order to import and export full **Registered Capacity** of the **DC Converter**. The **DC Converter Station** owner is responsible for ensuring that suitable arrangements are in place with the **Externally Interconnected System Operator** to facilitate the active power changes required by these tests
- OC5.A.4.5.2 The frequency controller shall be in **Frequency Sensitive Mode** or **Limited Frequency Sensitive Mode** as appropriate for each test. Simulated frequency deviation signals shall be injected into the frequency controller reference/feedback summing junction. If the injected frequency signal replaces rather than sums with the real system frequency signal then the additional tests outlined in OC5.A.4.5.6 shall be performed with the **DC Converter** in normal **Frequency Sensitive Mode** monitoring actual system frequency, over a period of at least 10 minutes. The aim of this additional test is to verify that the control system correctly measures the real system frequency for normal variations over a period of time.
- OC5.A.4.5.3 In addition to the frequency response requirements it is necessary to demonstrate the **DC Converter** ability to deliver a requested steady state power output which is not impacted by power source variation as per CC.6.3.9. This test shall be conducted in **Limited Frequency Sensitive Mode** at a part-loaded output for a period of 10 minutes as per OC5.A.4.5.6.

Preliminary Frequency Response Testing

OC5.A.4.5.4 Prior to conducting the full set of tests as per OC5.A.4.5.6, **DC Converter Station** owners are required to conduct a preliminary set of tests below to confirm the frequency injection method is correct and the plant control performance is within expectation. The test numbers refer to Figure 1 below. These tests should be scheduled at a time where there are sufficient MW resource in order to export full **Registered Capacity** from the **DC Converter**. The following frequency injections shall be applied when operating at module load point 4.

| Test No<br>(Figure 1) | Frequency Injection   | Notes |
|-----------------------|---|-------|
| 8                     | <ul style="list-style-type: none"> <li>Inject - 0.5Hz frequency fall over 10 sec</li> <li>Hold until conditions stabilise</li> <li>Remove the injected signal</li> </ul>  |       |
| 14                    | <ul style="list-style-type: none"> <li>Inject +0.5Hz frequency rise over 10 sec</li> <li>Hold until conditions stabilise</li> <li>Remove the injected signal</li> </ul>   |       |
| 13                    | <ul style="list-style-type: none"> <li>Inject -0.5Hz frequency fall over 10 sec</li> <li>Hold for a further 20 sec</li> <li>At 30 sec from the start of the test, Inject a +0.3Hz frequency rise over 30 sec.</li> <li>Hold until conditions stabilise</li> <li>Remove the injected signal</li> </ul> |       |

OC5.A.4.5.5 The recorded results (e.g. Finj, MW and control signals) should be sampled at a minimum rate of 1 Hz to allow **NGET** to assess the plant performance from the initial transients (seconds) to the final steady state conditions (5-15 minutes depending on the plant design). This is not witnessed by **NGET**. The **DC Converter Station** owner shall supply the recordings including data to **NGET** in an electronic spreadsheet format. Results shall be legible, identifiable by labelling, and shall have appropriate scaling.

Full Frequency Response Testing Schedule Witnessed by **NGET**

OC5.A.4.5.6 The tests are to be conducted at a number of different Module Load Points (MLP). In the case of a **DC Converter** the module load points are conducted as shown below unless agreed otherwise by **NGET**.

|  |            |
|--|------------|
| Module Load Point 6<br>( <b>Maximum Export Limit</b> )           | 100% MEL   |
| Module Load Point 5  | 90% MEL    |
| Module Load Point 4<br>(Mid point of Operating Range)            | 80% MEL    |
| Module Load Point 3  | DMOL + 20% |
| Module Load Point 2  | DMOL + 10% |
| Module Load Point 1<br>( <b>Design Minimum Operating Level</b> ) | DMOL       |

OC5.A.4.5.7 The tests are divided into the following two types;

- (i) Frequency response volume tests as per OC5.A.4.5. Figure 1. These tests consist of frequency profile and ramp tests.
- (ii) System islanding and step response tests as shown by OC5.A.4.5 Figure 2

OC5.A.4.5.8 There should be sufficient time allowed between tests for control systems to reach steady state (depending on available power resource). Where the diagram states 'HOLD' the current injection should be maintained until the **Active Power (MW)** output of the **DC Converter** has stabilised. All frequency response tests should be removed over the same timescale for which they were applied. **NGET** may require repeat tests should the response volume be affected by the available power, or if tests give unexpected results.

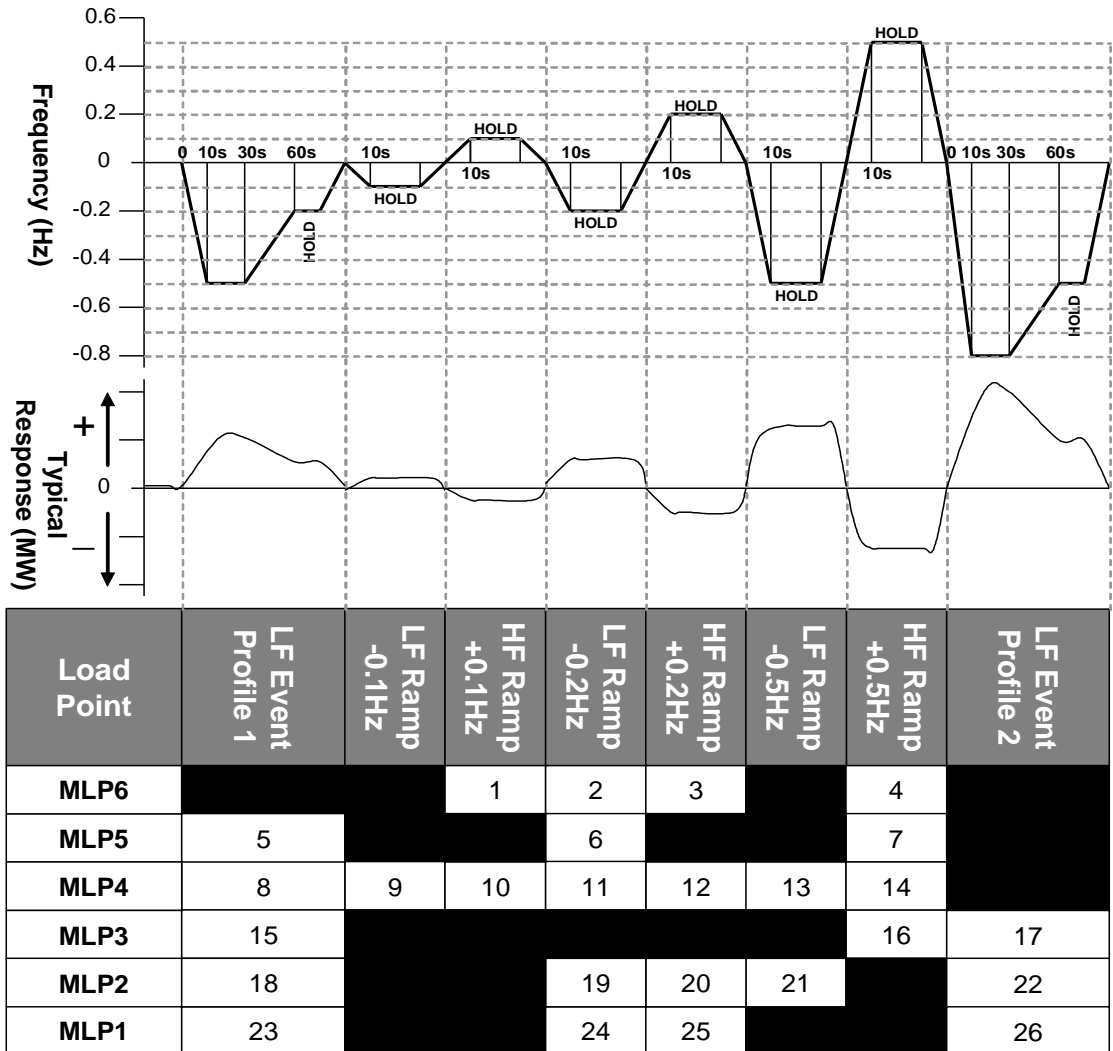

OC5.A.4.5. Figure 1 – Frequency response volume tests

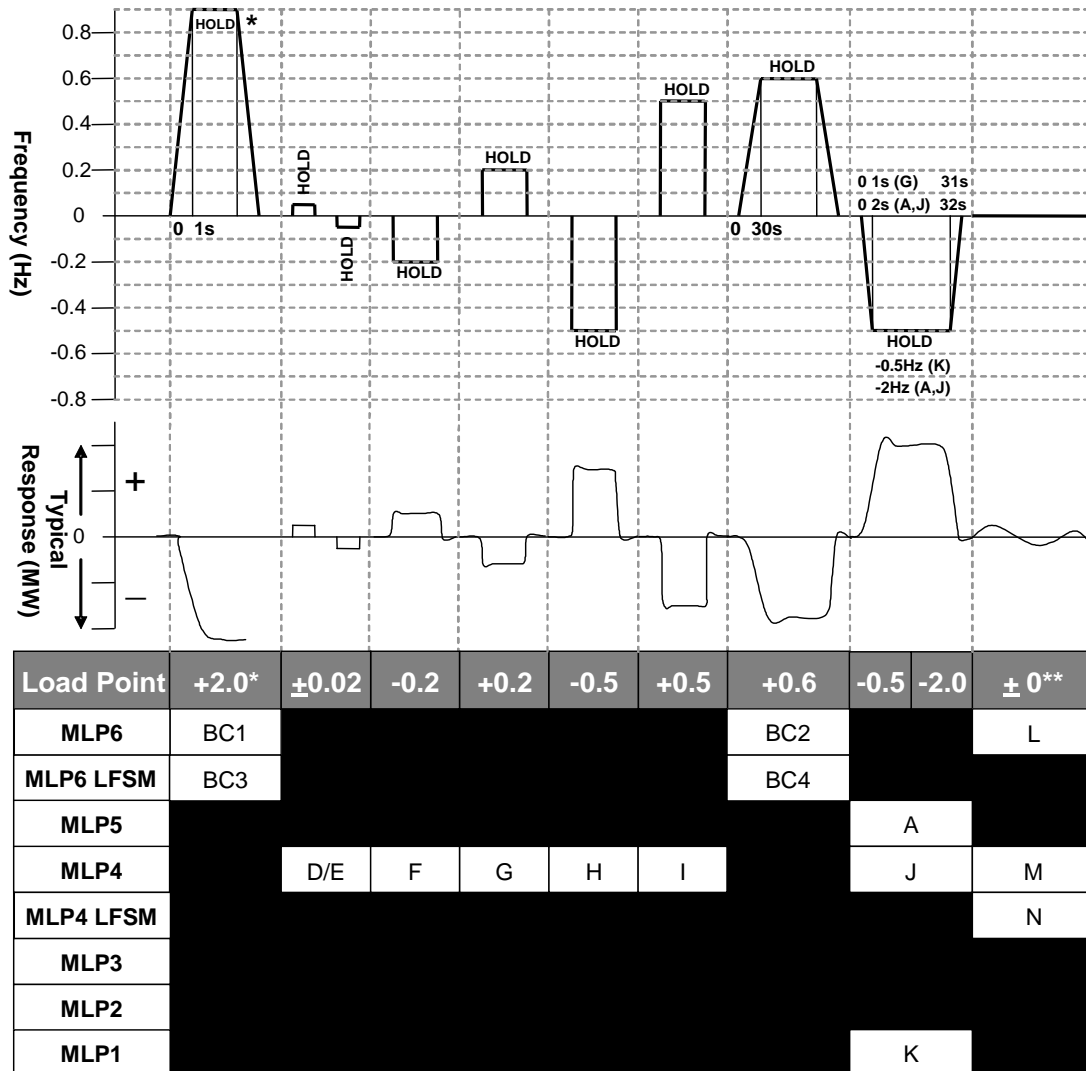

OC5.A.4.5. Figure 2 – System islanding and step response tests

\* This will generally be +2.0Hz unless an injection of this size causes a reduction in plant output that takes the operating point below **Designed Minimum Operating Level** in which case an appropriate injection should be calculated in accordance with the following:

For example 0.9Hz is needed to take an initial output 65% to a final output of 20%. If the initial output was not 65% and the **Designed Minimum Operating Level** is not 20% then the injected step should be adjusted accordingly as shown in the example given below

|   |  |
|---|--|
| Initial Output                          | 65%  |
| <b>Designed Minimum Operating Level</b> | 20%  |
| Frequency Controller Droop              | 4%   |
| Frequency to be injected =              | $(0.65 - 0.20) \times 0.04 \times 50 = 0.9\text{Hz}$ |

\*\* Tests L and M in Figure 2 shall be conducted if in this range of tests the system frequency feedback signal is replaced by the injection signal rather than the injection signal being added to the system frequency signal. The tests will consist of monitoring the **DC Converter** in **Frequency Sensitive Mode** during normal system frequency variations without applying any injection. Test N in Figure 2 shall be conducted in all cases. All three tests should be conducted for a period of at least 10 minutes.

< END OF OPERATING CODE NO. 5 >





# OPERATING CODE NO. 7

(OC7)

## OPERATIONAL LIAISON

### CONTENTS

(This contents page does not form part of the Grid Code)

| <u>Paragraph No/Title</u>  | <u>Page Number</u> |
|--|--------------------|
| OC7.1 INTRODUCTION.....  | 2                  |
| OC7.2 OBJECTIVE .....  | 2                  |
| OC7.3 SCOPE.....   | 3                  |
| OC7.4 PROCEDURE .....  | 3                  |
| OC7.4.5 Requirement To Notify Operations.....  | 3                  |
| OC7.4.6 Requirements To Notify Events.....   | 6                  |
| OC7.4.7 Significant Incidents.....   | 9                  |
| Oc7.4.8 National Electricity Transmission System Warnings.....                       | 9                  |
| OC7.5 PROCEDURE IN RELATION TO INTEGRAL EQUIPMENT TESTS .....                        | 12                 |
| OC7.6 PROCEDURE IN RESPECT OF OPERATIONAL SWITCHING IN SCOTLAND AND<br>OFFSHORE..... | 14                 |
| APPENDIX 1 - NATIONAL ELECTRICITY TRANSMISSION SYSTEM WARNINGS TABLE .....           | 17                 |

OC7.1 INTRODUCTION

OC7.1.1 **Operating Code No. 7 ("OC7")** sets out the requirements for the exchange of information in relation to **Operations** and/or **Events** on the **Total System** which have had (or may have had) or will have (or may have) an **Operational Effect**:

- (a) on the **National Electricity Transmission System** in the case of an **Operation** and/or **Event** occurring on the **System** of a **User** or **Users**; and
- (b) on the **System** of a **User** or **Users** in the case of an **Operation** and/or **Event** occurring on the **National Electricity Transmission System**.

It also describes the types of **National Electricity Transmission System Warning** which may be issued by **NGET**.

OC7.1.2 The requirement to notify in **OC7** relates generally to notifying of what is expected to happen or what has happened and not the reasons why. However, as **OC7** provides, when an **Event** or **Operation** has occurred on the **National Electricity Transmission System** which itself has been caused by (or exacerbated by) an **Operation** or **Event** on a **User's System**, **NGET** in reporting the **Event** or **Operation** on the **National Electricity Transmission System** to another **User** can pass on what it has been told by the first **User** in relation to the **Operation** or **Event** on the first **User's System**.

OC7.1.3 Where an **Event** or **Operation** on the **National Electricity Transmission System** falls to be reported by **NGET** to an **Externally Interconnected System Operator** under an **Interconnection Agreement**, **OC7** provides that in the situation where that **Event** or **Operation** has been caused by (or exacerbated by) an **Operation** or **Event** on a **User's System**, **NGET** can pass on what it has been told by the **User** in relation to the **Operation** or **Event** on that **User's System**.

OC7.1.4 **OC7** also deals with **Integral Equipment Tests**.

OC7.1.5 To reconfigure the **National Electricity Transmission System**, **NGET** may reasonably require the assistance of a **User** to reconfigure parts of the **User System**. To reconfigure its **User System** a **User** may reasonably require the reasonable assistance of **NGET** to direct the reconfiguration of parts of the **National Electricity Transmission System**.

OC7.1.6 **OC7.6** sets down the arrangements for the exchange of information required when configuring **Connection Sites** (or in the case of **OTSUA** operational prior to the **OTSUA Transfer Time**, **Transmission Interface Sites**) and parts of the **National Electricity Transmission System** adjacent to those **Connection Sites** (or **Transmission Interface Sites**) in Scotland and **Offshore**. It also covers the setting up of a **Local Switching Procedure**. **NGET** shall procure that **Relevant Transmission Licensees** shall comply with section **OC7.6** and any relevant **Local Switching Procedure** where and to the extent that such matters apply to them.

OC7.2 OBJECTIVE

The objectives of **OC7** are:

OC7.2.1 To provide for the exchange of information so that the implications of an **Operation** and/or **Event** can be considered, possible risks arising from it can be assessed and appropriate action taken by the relevant party in order to maintain the integrity of the **Total System**. **OC7** does not seek to deal with any actions arising from the exchange of information, but merely with that exchange.

OC7.2.2 To provide for types of **National Electricity Transmission System Warnings** which may be issued by **NGET**.

OC7.2.3 To provide the framework for the information flow and discussion between **NGET** and certain **Users** in relation to **Integral Equipment Tests**.

OC7.2.4 To provide the procedure to be followed in respect of **Operational Switching** in Scotland and **Offshore**.

### OC7.3 SCOPE

OC7.3.1 **OC7** applies to **NGET** and to **Users**, which in **OC7** means:

- (a) **Generators** (other than those which only have **Embedded Small Power Stations** or **Embedded Medium Power Stations**) **and including Generators undertaking OTSDUW**;
- (b) **Network Operators**;
- (c) **Non-Embedded Customers**;
- (d) **Suppliers** (for the purposes of **National Electricity Transmission System Warnings**);
- (e) **Externally Interconnected System Operators** (for the purposes of **National Electricity Transmission System Warnings**); and
- (f) **DC Converter Station** owners.

The procedure for operational liaison by **NGET** with **Externally Interconnected System Operators** is set out in the **Interconnection Agreement** with each **Externally Interconnected System Operator**.

In Scotland and **Offshore** OC7.6 also applies to **Relevant Transmission Licensees**.

### OC7.4 PROCEDURE

OC7.4.1 The term "**Operation**" means a scheduled or planned action relating to the operation of a **System** (including an **Embedded Power Station**).

OC7.4.2 The term "**Event**" means an unscheduled or unplanned (although it may be anticipated) occurrence on, or relating to, a **System** (including an **Embedded Power Station**) including, without limiting that general description, faults, incidents and breakdowns and adverse weather conditions being experienced.

OC7.4.3 The term "**Operational Effect**" means any effect on the operation of the relevant other **System** which causes the **National Electricity Transmission System** or the **Systems** of the other **User** or **Users**, as the case may be, to operate (or be at a materially increased risk of operating) differently to the way in which they would or may have normally operated in the absence of that effect.

OC7.4.4 References in this **OC7** to a **System** of a **User** or **User's System** shall not include **Embedded Small Power Stations** or **Embedded Medium Power Stations**, unless otherwise stated.

#### OC7.4.5 Requirement To Notify Operations

##### OC7.4.5.1 Operation On The National Electricity Transmission System

In the case of an **Operation** on the **National Electricity Transmission System**, which will have (or may have) an **Operational Effect** on the **System(s)** of a **User** or **Users**, **NGET** will notify the **User** or **Users** whose **System(s)** will, or may, in the reasonable opinion of **NGET**, be affected, in accordance with **OC7**.

##### OC7.4.5.2 Operation On A User's System

In the case of an **Operation** on the **System** of a **User** which will have (or may have) an **Operational Effect** on the **National Electricity Transmission System** (including an equivalent to an **Operation** on the equivalent of a **System** of a **User** or other person connected to that **User's System** which, via that **User System**, will or may have an **Operational Effect** on the **National Electricity Transmission System**), the **User** will notify **NGET** in accordance with **OC7**. Following notification by the **User**, **NGET** will notify any other **User** or **Users** on whose **System(s)** the **Operation** will have, or may have, in the reasonable opinion of **NGET**, an **Operational Effect**, in accordance with **OC7** and will notify any **Externally Interconnected System Operator** on whose **System** the **Operation** will have, or may have, in the reasonable opinion of **NGET**, an **Operational Effect**, if it is required to do so by the relevant **Interconnection Agreement**.

#### OC7.4.5.3 Examples Of Situations Where Notification By NGET Or A User May Be Required

Whilst in no way limiting the general requirement to notify in advance set out in OC7.4.5.1 and OC7.4.5.2, the following are examples of situations where notification in accordance with OC7.4.5 will be required if they will, or may, have an **Operational Effect**:

- (a) the implementation of a planned outage of **Plant** and/or **Apparatus** which has been arranged pursuant to **OC2**;
- (b) the operation (other than, in the case of a **User**, at the instruction of **NGET**) of any circuit breaker or isolator/disconnector or any sequence or combination of the two; or
- (c) voltage control.

#### OC7.4.5.4 Operations Caused By Another Operation Or By An Event

An **Operation** may be caused by another **Operation** or an **Event** on another's **System** (including an **Embedded Power Station**) (or by the equivalent of an **Event** or **Operation** on the **System** of an **Externally Interconnected System Operator** or **Interconnector User**) and in that situation the information to be notified is different to that where the **Operation** arose independently of any other **Operation** or **Event**, as more particularly provided in OC7.4.5.6.

#### OC7.4.5.5 Form

A notification and any response to any questions asked under OC7.4.5, of an **Operation** which has arisen independently of any other **Operation** or of an **Event**, shall be of sufficient detail to describe the **Operation** (although it need not state the cause) and to enable the recipient of the notification reasonably to consider and assess the implications and risks arising (provided that, in the case of an **Operation** on a **User's System** which **NGET** is notifying to other **Users** under OC7.4.5.2, **NGET** will only pass on what it has been told by the **User** which has notified it) and will include the name of the individual reporting the **Operation** on behalf of **NGET** or the **User**, as the case may be. The recipient may ask questions to clarify the notification and the giver of the notification will, insofar as it is able, answer any questions raised, provided that, in the case of an **Operation** on a **User's System** which **NGET** is notifying to other **Users** under OC7.4.5.2, in answering any question, **NGET** will not pass on anything further than that which it has been told by the **User** which has notified it. **NGET** may pass on the information contained in the notification as provided in OC7.4.5.6.

- OC7.4.5.6
- (a) A notification by **NGET** of an **Operation** under OC7.4.5.1 which has been caused by another **Operation** (the "first **Operation**") or by an **Event** on a **User's System**, will describe the **Operation** and will contain the information which **NGET** has been given in relation to the first **Operation** or that **Event** by the **User**. The notification and any response to any questions asked (other than in relation to the information which **NGET** is merely passing on from a **User**) will be of sufficient detail to enable the recipient of the notification reasonably to consider and assess the implications and risks arising from the **Operation** on the **National Electricity Transmission System** and will include the name of the individual reporting the **Operation** on behalf of **NGET**. The recipient may ask questions to clarify the notification and **NGET** will, insofar as it is able, answer any questions raised, provided that in relation to the information which **NGET** is merely passing on from a **User**, in answering any question **NGET** will not pass on anything further than that which it has been told by the **User** which has notified it.
  - (b) Where a **User** is reporting an **Operation** or an **Event** which itself has been caused by an incident or scheduled or planned action affecting (but not on) its **System**, the notification to **NGET** will contain the information which the **User** has been given by the person connected to its **System** in relation to that incident or scheduled or planned action (which the **User** must require, contractually or otherwise, the person connected to its **System** to give to it) and **NGET** may pass on the information contained in the notification as provided in this OC7.4.5.6.

- OC7.4.5.7 Where an **Operation** on the **National Electricity Transmission System** falls to be reported by **NGET** under an **Interconnection Agreement** and the **Operation** has been caused by another **Operation** (the "first **Operation**") or by an **Event** on a **User's System**, **NGET** will include in that report the information which **NGET** has been given in relation to the first **Operation** or that **Event** by the **User** (including any information relating to an incident or scheduled or planned action, as provided in OC7.4.5.6).
- OC7.4.5.8 (a) A notification to a **User** by **NGET** of an **Operation** under OC7.4.5.1 which has been caused by the equivalent of an **Operation** or of an **Event** on the equivalent of a **System** of an **Externally Interconnected System Operator** or **Interconnector User**, will describe the **Operation** on the **National Electricity Transmission System** and will contain the information which **NGET** has been given, in relation to the equivalent of an **Operation** or of an **Event** on the equivalent of a **System** of an **Externally Interconnected System Operator** or **Interconnector User**, by that **Externally Interconnected System Operator** or **Interconnector User**.
- (b) The notification and any response to any question asked (other than in relation to the information which **NGET** is merely passing on from that **Externally Interconnected System Operator** or **Interconnector User**) will be of sufficient detail to enable the recipient of the notification reasonably to consider and assess the implications and risks arising from the **Operation** on the **National Electricity Transmission System** and will include the name of the individual reporting the **Operation** on behalf of **NGET**. The recipient may ask questions to clarify the notification and **NGET** will, insofar as it is able, answer any questions raised, provided that, in relation to the information which **NGET** is merely passing on from an **Externally Interconnected System Operator** or **Interconnector User**, in answering any question **NGET** will not pass on anything further than that which it has been told by the **Externally Interconnected System Operator** or **Interconnector User** which has notified it.
- OC7.4.5.9 (a) A **Network Operator** may pass on the information contained in a notification to it from **NGET** under OC7.4.5.1, to a **Generator** with a **Generating Unit** or a **Power Park Module** connected to its **System**, or to a **DC Converter Station** owner with a **DC Converter** connected to its **System**, or to the operator of another **User System** connected to its **System** (which, for the avoidance of doubt, could be another **Network Operator**), in connection with reporting the equivalent of an **Operation** under the **Distribution Code** (or the contract pursuant to which that **Generating Unit** or **Power Park Module** or other **User System**, or to a **DC Converter Station** is connected to the **System** of that **Network Operator**) (if the **Operation** on the **National Electricity Transmission System** caused it).
- (b) A **Generator** may pass on the information contained in a notification to it from **NGET** under OC7.4.5.1, to another **Generator** with a **Generating Unit** or a **Power Park Module** connected to its **System**, or to the operator of a **User System** connected to its **System** (which, for the avoidance of doubt, could be a **Network Operator**), if it is required (by a contract pursuant to which that **Generating Unit** or that **Power Park Module** or that **User System** is connected to its **System**) to do so in connection with the equivalent of an **Operation** on its **System** (if the **Operation** on the **National Electricity Transmission System** caused it).
- OC7.4.5.10 (a) Other than as provided in OC7.4.5.9, a **Network Operator** or a **Generator** may not pass on any information contained in a notification to it from **NGET** under OC7.4.5.1 (and an operator of a **User System** or **Generator** receiving information which was contained in a notification to a **Generator** or a **Network Operator**, as the case may be, from **NGET** under OC7.4.5.1, as envisaged in OC7.4.5.9 may not pass on this information) to any other person, but may inform persons connected to its **System** (or in the case of a **Generator** which is also a **Supplier**, inform persons to which it supplies electricity which may be affected) that there has been an incident on the **Total System**, the general nature of the incident (but not the cause of the incident) and (if known and if power supplies have been affected) an estimated time of return to service.

- (b) In the case of a **Generator** which has an **Affiliate** which is a **Supplier**, the **Generator** may inform it that there has been an incident on the **Total System**, the general nature of the incident (but not the cause of the incident) and (if known and if power supplies have been affected in a particular area) an estimated time of return to service in that area, and that **Supplier** may pass this on to persons to which it supplies electricity which may be affected).
- (c) Each **Network Operator** and **Generator** shall use its reasonable endeavours to procure that any **Generator** or operator of a **User System** receiving information which was contained in a notification to a **Generator** or **Network Operator**, as the case may be, from **NGET** under OC7.4.5.1, which is not bound by the **Grid Code**, does not pass on any information other than as provided above.

OC7.4.5.11 The notification will, if either party requests, be recorded by the sender and dictated to the recipient, who shall record and repeat each phrase as it is received and on completion of the dictation shall repeat back the notification in full to the sender who shall confirm that it has been accurately recorded.

OC7.4.5.12 Timing

A notification under OC7.4.5 will be given as far in advance as possible and in any event shall be given in sufficient time as will reasonably allow the recipient to consider and assess the implications and risks arising.

OC7.4.6 Requirements To Notify Events

OC7.4.6.1 Events On The National Electricity Transmission System

In the case of an **Event** on the **National Electricity Transmission System** which has had (or may have had) an **Operational Effect** on the **System(s)** of a **User** or **Users**, **NGET** will notify the **User** or **Users** whose **System(s)** have been, or may have been, in the reasonable opinion of **NGET**, affected, in accordance with **OC7**.

OC7.4.6.2 Events On A User's System

In the case of an **Event** on the **System** of a **User** which has had (or may have had) an **Operational Effect** on the **National Electricity Transmission System**, the **User** will notify **NGET** in accordance with **OC7**.

OC7.4.6.3 Events Caused By Another Event Or By An Operation

An **Event** may be caused (or exacerbated by) another **Event** or by an **Operation** on another's **System** (including on an **Embedded Power Station**) (or by the equivalent of an **Event** or **Operation** on the equivalent of a **System** of an **Externally Interconnected System Operator** or **Interconnector User**) and in that situation the information to be notified is different to that where the **Event** arose independently of any other **Event** or **Operation**, as more particularly provided in OC7.4.6.7.

OC7.4.6.4 **NGET** or a **User**, as the case may be, may enquire of the other whether an **Event** has occurred on the other's **System**. If it has, and the party on whose **System** the **Event** has occurred is of the opinion that it may have had an **Operational Effect** on the **System** of the party making the enquiry, it shall notify the enquirer in accordance with **OC7**.

OC7.4.6.5 Examples Of Situations Where Notification By NGET Or A User May Be Required

Whilst in no way limiting the general requirement to notify set out in OC7.4.6.1, OC7.4.6.2 and OC7.4.6.3, the following are examples of situations where notification in accordance with OC7.4.6 will be required if they have an **Operational Effect**:

- (a) where **Plant** and/or **Apparatus** is being operated in excess of its capability or may present a hazard to personnel;
- (b) the activation of any alarm or indication of any abnormal operating condition;
- (c) adverse weather conditions being experienced;
- (d) breakdown of, or faults on, or temporary changes in the capabilities of, **Plant** and/or **Apparatus**;

- (e) breakdown of, or faults on, control, communication and metering equipment; or
- (f) increased risk of inadvertent protection operation.

Form

- OC7.4.6.6 A notification and any response to any questions asked under OC7.4.6.1 and OC7.4.6.2 of an **Event** which has arisen independently of any other **Event** or of an **Operation**, will describe the **Event**, although it need not state the cause of the **Event**, and, subject to that, will be of sufficient detail to enable the recipient of the notification reasonably to consider and assess the implications and risks arising and will include the name of the individual reporting the **Event** on behalf of **NGET** or the **User**, as the case may be. The recipient may ask questions to clarify the notification and the giver of the notification will, insofar as it is able (although it need not state the cause of the **Event**) answer any questions raised. **NGET** may pass on the information contained in the notification as provided in OC7.4.6.7.
- OC7.4.6.7 (a) A notification (and any response to any questions asked under OC7.4.6.1) by **NGET** of (or relating to) an **Event** under OC7.4.6.1 which has been caused by (or exacerbated by) another **Event** (the "first **Event**") or by an **Operation** on a **User's System** will describe the **Event** and will contain the information which **NGET** has been given in relation to the first **Event** or that **Operation** by the **User** (but otherwise need not state the cause of the **Event**). The notification and any response to any questions asked (other than in relation to the information which **NGET** is merely passing on from a **User**) will be of sufficient detail to enable the recipient of the notification reasonably to consider and assess the implications and risks arising from the **Event** on the **National Electricity Transmission System** and will include the name of the individual reporting the **Event** on behalf of **NGET**. The recipient may ask questions to clarify the notification and **NGET** will, insofar as it is able, answer any questions raised, provided that in relation to the information which **NGET** is merely passing on from a **User**, in answering any question **NGET** will not pass on anything further than that which it has been told by the **User** which has notified it.
- (b) Where a **User** is reporting an **Event** or an **Operation** which itself has been caused by (or exacerbated by) an incident or scheduled or planned action affecting (but not on) its **System** the notification to **NGET** will contain the information which the **User** has been given by the person connected to its **System** in relation to that incident or scheduled or planned action (which the **User** must require, contractually or otherwise, the person connected to its **System** to give to it) and **NGET** may pass on the information contained in the notification as provided in this OC7.4.6.7.
- OC7.4.6.8 Where an **Event** on the **National Electricity Transmission System** falls to be reported by **NGET** under an **Interconnection Agreement** and the **Event** has been caused by (or exacerbated by) another **Event** (the "first **Event**") or by an **Operation** on a **User's System**, **NGET** will include in that report the information which **NGET** has been given in relation to the first **Event** or that **Operation** by the **User** (including any information relating to an incident or scheduled or planned action on that **User's System**, as provided in OC7.4.6.7).
- OC7.4.6.9 (a) A notification to a **User** (and any response to any questions asked under OC7.4.6.1) by **NGET** of (or relating to) an **Event** under OC7.4.6.1 which has been caused by (or exacerbated by) the equivalent of an **Event** or of an **Operation** on the equivalent of a **System** of an **Externally Interconnected System Operator** or **Interconnector User**, will describe the **Event** on the **National Electricity Transmission System** and will contain the information which **NGET** has been given, in relation to the equivalent of an **Event** or of an **Operation** on the equivalent of a **System** of an **Externally Interconnected System Operator** or **Interconnector User**, by that **Externally Interconnected System Operator** or **Interconnector User** (but otherwise need not state the cause of the **Event**).

- (b) The notification and any response to any questions asked (other than in relation to the information which **NGET** is merely passing on from that **Externally Interconnected System Operator** or **Interconnector User**) will be of sufficient detail to enable the recipient of the notification reasonably to consider and assess the implications and risks arising from the **Event** on the **National Electricity Transmission System** and will include the name of the individual reporting the **Event** on behalf of **NGET**. The recipient may ask questions to clarify the notification and **NGET** will, insofar as it is able (although it need not state the cause of the **Event**) answer any questions raised, provided that, in relation to the information which **NGET** is merely passing on from an **Externally Interconnected System Operator** or **Interconnector User**, in answering any question **NGET** will not pass on anything further than that which it has been told by the **Externally Interconnected System Operator** or **Interconnector User** which has notified it.

OC7.4.6.10 (a) A **Network Operator** may pass on the information contained in a notification to it from **NGET** under OC7.4.6.1, to a **Generator** with a **Generating Unit** or a **Power Park Module** connected to its **System** or to a **DC Converter Station** owner with a **DC Converter** connected to its **System** or to the operator of another **User System** connected to its **System** (which, for the avoidance of doubt, could be a **Network Operator**), in connection with reporting the equivalent of an **Event** under the **Distribution Code** (or the contract pursuant to which that **Generating Unit** or **Power Park Module** or **DC Converter** or other **User System** is connected to the **System** of that **Network Operator**) (if the **Event** on the **National Electricity Transmission System** caused or exacerbated it).

- (b) A **Generator** may pass on the information contained in a notification to it from **NGET** under OC7.4.6.1, to another **Generator** with a **Generating Unit** or a **Power Park Module** connected to its **System** or to the operator of a **User System** connected to its **System** (which, for the avoidance of doubt, could be a **Network Operator**), if it is required (by a contract pursuant to which that **Generating Unit** or that **Power Park Module** or that **User System** is connected to its **System**) to do so in connection with the equivalent of an **Event** on its **System** (if the **Event** on the **National Electricity Transmission System** caused or exacerbated it).

OC7.4.6.11 (a) Other than as provided in OC7.4.6.10, a **Network Operator** or a **Generator**, may not pass on any information contained in a notification to it from **NGET** under OC7.4.6.1 (and an operator of a **User System** or **Generator** receiving information which was contained in a notification to a **Generator** or a **Network Operator**, as the case may be, from **NGET** under OC7.4.6.1, as envisaged in OC7.4.6.10 may not pass on this information) to any other person, but may inform persons connected to its **System** (or in the case of a **Generator** which is also a **Supplier**, inform persons to which it supplies electricity which may be affected) that there has been an incident on the **Total System**, the general nature of the incident (but not the cause of the incident) and (if known and if power supplies have been affected) an estimated time of return to service.

- (b) In the case of a **Generator** which has an **Affiliate** which is a **Supplier**, the **Generator** may inform it that there has been an incident on the **Total System**, the general nature of the incident (but not the cause of the incident) and (if known and if power supplies have been affected in a particular area) an estimated time of return to service in that area, and that **Supplier** may pass this on to persons to which it supplies electricity which may be affected).

- (c) Each **Network Operator** and **Generator** shall use its reasonable endeavours to procure that any **Generator** or operator of a **User System** receiving information which was contained in a notification to a **Generator** or **Network Operator**, as the case may be, from **NGET** under OC7.4.6.1, which is not bound by the **Grid Code**, does not pass on any information other than as provided above.



OC7.4.6.12 When an **Event** relating to a **Generating Unit**, **a Power Park Module** or **a DC Converter** (or OTSUA operational prior to the OTSUA Transfer Time), has been reported to **NGET** by a **Generator** or **DC Converter Station** owner under OC7.4.6 and it is necessary in order for the **Generator** or **DC Converter Station** owner to assess the implications of the **Event** on its **System** more accurately, the **Generator** or **DC Converter Station** owner may ask **NGET** for details of the fault levels from the **National Electricity Transmission System** to that **Generating Unit**, **Power Park Module** or **DC Converter** (or OTSUA operational prior to the OTSUA Transfer Time) at the time of the **Event**, and **NGET** will, as soon as reasonably practicable, give the **Generator** or **DC Converter Station** owner that information provided that **NGET** has that information.

OC7.4.6.13 Except in an emergency situation the notification of an **Event** will, if either party requests, be recorded by the sender and dictated to the recipient, who shall record and repeat each phrase as it is received and on completion of the dictation shall repeat the notification in full to the sender who shall confirm that it has been accurately recorded.

#### Timing

OC7.4.6.14 A notification under OC7.4.6 shall be given as soon as possible after the occurrence of the **Event**, or time that the **Event** is known of or anticipated by the giver of the notification under **OC7**, and in any event within 15 minutes of such time.

#### OC7.4.7 Significant Incidents

OC7.4.7.1 Where a **User** notifies **NGET** of an **Event** under **OC7** which **NGET** considers has had or may have had a significant effect on the **National Electricity Transmission System**, **NGET** will require the **User** to report that **Event** in writing in accordance with the provisions of **OC10** and will notify that **User** accordingly.

OC7.4.7.2 Where **NGET** notifies a **User** of an **Event** under **OC7** which the **User** considers has had or may have had a significant effect on that **User's System**, that **User** will require **NGET** to report that **Event** in writing in accordance with the provisions of **OC10** and will notify **NGET** accordingly.

OC7.4.7.3 **Events** which **NGET** requires a **User** to report in writing pursuant to OC7.4.7.1, and **Events** which a **User** requires **NGET** to report in writing pursuant to OC7.4.7.2, are known as "**Significant Incidents**".

OC7.4.7.4 Without limiting the general description set out in OC7.4.7.1 and OC7.4.7.2, a **Significant Incident** will include **Events** having an **Operational Effect** which result in, or may result in, the following:

- (a) operation of **Plant** and/or **Apparatus** either manually or automatically;
- (b) voltage outside statutory limits;
- (c) **Frequency** outside statutory limits; or
- (d) **System** instability.

#### OC 7.4.8 National Electricity Transmission System Warnings

##### OC7.4.8.1 Role Of National Electricity Transmission System Warnings

**National Electricity Transmission System Warnings** as described below provide information relating to **System** conditions or **Events** and are intended to:

- (i) alert **Users** to possible or actual **Plant** shortage, **System** problems and/or **Demand** reductions;
- (ii) inform of the applicable period;
- (iii) indicate intended consequences for **Users**; and
- (iv) enable specified **Users** to be in a state of readiness to react properly to instructions received from **NGET**.

A table of **National Electricity Transmission System Warnings**, set out in the Appendix to **OC7**, summarises the warnings and their usage. In the case of a conflict between the table and the provisions of the written text of **OC7**, the written text will prevail.

#### OC7.4.8.2 Recipients Of National Electricity Transmission System Warnings

- (a) Where **National Electricity Transmission System Warnings**, (except those relating to **Demand Control Imminent**), are applicable to **System** conditions or **Events** which have widespread effect, **NGET** will notify all **Users** under **OC7**.
- (b) Where in **NGET's** judgement **System** conditions or **Events** may only have a limited effect, the **National Electricity Transmission System Warning** will only be issued to those **Users** who are or may in **NGET's** judgement be affected.
- (c) Where a **National Electricity Transmission System Warning - Demand Control Imminent** is issued it will only be sent to those **Users** who are likely to receive **Demand Control** instructions from **NGET**.

#### OC7.4.8.3 Preparatory Action

- (a) Where possible, and if required, recipients of the warnings should take such preparatory action as they deem necessary taking into account the information contained in the **National Electricity Transmission System Warning**. All warnings will be of a form determined by **NGET** and will remain in force from the stated time of commencement until the cancellation, amendment or re-issue, as the case may be, is notified by **NGET**.
- (b) Where a **National Electricity Transmission System Warning** has been issued to a **Network Operator** and is current, **Demand Control** should not (subject as provided below) be employed unless instructed by **NGET**. If **Demand Control** is, however, necessary to preserve the integrity of the **Network Operator's System**, then the impact upon the integrity of the **Total System** should be considered by the **Network Operator** and where practicable discussed with **NGET** prior to its implementation.

Where a **National Electricity Transmission System Warning** has been issued to a **Supplier**, further **Customer Demand Management** (in addition to that previously notified under **OC1 - Demand Forecasts**) must only be implemented following notification to **NGET**.

- (c) **National Electricity Transmission System Warnings** will be issued by such data transmission facilities as have been agreed between **NGET** and **Users**. In the case of **Generators** with **Gensets** this will normally be at their **Trading Points** (if they have notified **NGET** that they have a **Trading Point**).
- (d) **Users** may at times be informed by telephone of **National Electricity Transmission System Warnings** and in these circumstances confirmation will be sent to those **Users** so notified by such data transmission facilities as have been agreed between **NGET** and **Users**, as soon as possible.

#### OC7.4.8.4 Types Of National Electricity Transmission System Warnings

**National Electricity Transmission System Warnings** consist of the following types:-

- (i) **National Electricity Transmission System Warning - Inadequate System Margin**
- (ii) **National Electricity Transmission System Warning - High Risk of Demand Reduction**
- (iii) **National Electricity Transmission System Warning - Demand Control Imminent**
- (iv) **National Electricity Transmission System Warning - Risk of System Disturbance**

#### OC7.4.8.5 National Electricity Transmission System Warning - Inadequate System Margin

A **National Electricity Transmission System Warning - Inadequate System Margin** may be issued to **Users** in accordance with OC7.4.8.2, at times when there is inadequate **System Margin**, as determined under BC1.5.4. It will contain the following information:

- (i) the period for which the warning is applicable; and
- (ii) the availability shortfall in MW; and

- (iii) intended consequences for **Users**, including notification that **Maximum Generation Service** may be instructed.

OC 7.4.8.6 National Electricity Transmission System Warning - High Risk of Demand Reduction

- (a) A **National Electricity Transmission System Warning - High Risk of Demand Reduction** may be issued to **Users** in accordance with OC7.4.8.2 at times when there is inadequate **System Margin**, as determined under BC1.5.4 and in **NGET's** judgement there is increased risk of **Demand** reduction being implemented under OC6.5.1. It will contain the following information in addition to the required information in a **National Electricity Transmission System Warning - Inadequate System Margin**:
  - (i) the possible percentage level of **Demand** reduction required; and
  - (ii) Specify those **Network Operators** and **Non Embedded Customers** who may subsequently receive instructions under OC6.5.1.
- (b) A **National Electricity Transmission System Warning - High Risk of Demand Reduction** may also be issued by **NGET** to those **Network Operators** and **Non Embedded Customers** who may subsequently receive instructions under OC6.5.1 relating to a **Demand** reduction in circumstances not related to inadequate **System Margin** (for example **Demand** reduction required to manage **System** overloading).

The **National Electricity Transmission System Warning - High Risk of Demand Reduction** will specify the period during which **Demand** reduction may be required and the part of the **Total System** to which it applies and any other matters specified in OC6.5.

OC7.4.8.6.1 Protracted Periods Of Generation Shortage

- (a) Whenever **NGET** anticipates that a protracted period of generation shortage may exist a **National Electricity Transmission System Warning - Inadequate System Margin** or **High Risk of Demand Reduction** may be issued, to give as much notice as possible to those **Network Operators** and **Non Embedded Customers** who may subsequently receive instructions under OC6.5.
- (b) A **National Electricity Transmission System Warning - High Risk of Demand Reduction** will in these instances include an estimate of the percentage of **Demand** reduction that may be required and the anticipated duration of the **Demand** reduction. It may also include information relating to estimates of any further percentage of **Demand** reduction that may be required.
- (c) The issue of the **National Electricity Transmission System Warning - Inadequate System Margin** or **High Risk of Demand Reduction** is intended to enable recipients to plan ahead on the various aspects of **Demand** reduction.

OC7.4.8.7 National Electricity Transmission System Warning - Demand Control Imminent

- (a) A **National Electricity Transmission System Warning - Demand Control Imminent**, relating to a **Demand** reduction under OC6.5, will be issued by **NGET** to **Users** in accordance with OC7.4.8.2. It will specify those **Network Operators** who may subsequently receive instructions under OC6.5.
- (b) A **National Electricity Transmission System Warning - Demand Control Imminent**, need not be preceded by any other **National Electricity Transmission System Warning** and will be issued when a **Demand** reduction is expected within the following 30 minutes, but will not cease to have effect after 30 minutes from its issue. However, **NGET** will either reissue the **National Electricity Transmission System Warning - Demand Control Imminent** or cancel the **National Electricity Transmission System Warning - Demand Control Imminent** no later than 2 hours from first issue, or from re-issue, as the case may be.

OC7.4.8.8 National Electricity Transmission System Warning - Risk of System Disturbance

- (a) A **National Electricity Transmission System Warning - Risk of System Disturbance** will be issued by **NGET** to **Users** who may be affected when **NGET** knows there is a risk of widespread and serious disturbance to the whole or part of, the **National Electricity Transmission System**;
- (b) The **National Electricity Transmission System Warning - Risk of System Disturbance** will contain such information as **NGET** deems appropriate;
- (c) for the duration of the **National Electricity Transmission System Warning - Risk of System Disturbance**, each **User** in receipt of the **National Electricity Transmission System Warning - Risk of System Disturbance** shall take the necessary steps to warn its operational staff and to maintain its **Plant** and/or **Apparatus** in the condition in which it is best able to withstand the anticipated disturbance;
- (d) During the period that the **National Electricity Transmission System Warning - Risk of System Disturbance** is in effect, **NGET** may issue **Emergency Instructions** in accordance with **BC2** and it may be necessary to depart from normal **Balancing Mechanism** operation in accordance with **BC2** in issuing **Bid-Offer Acceptances**.

OC7.4.8.9 Cancellation of National Electricity Transmission System Warning

- (a) **NGET** will give notification of a **Cancellation of National Electricity Transmission System Warning** to all **Users** issued with the **National Electricity Transmission System Warning** when in **NGET's** judgement **System** conditions have returned to normal.
- (b) A **Cancellation of National Electricity Transmission System Warning** will identify the type of **National Electricity Transmission System Warning** being cancelled and the period for which it was issued. The **Cancellation of National Electricity Transmission System Warning** will also identify any **National Electricity Transmission System Warnings** that are still in force.

OC7.4.8.10 General Management Of National Electricity Transmission System Warnings

- (a) **National Electricity Transmission System Warnings** remain in force for the period specified unless superseded or cancelled by **NGET**.
- (b) A **National Electricity Transmission System Warning** issued for a particular period may be superseded by further related warnings. This will include **National Electricity Transmission System Warning - Inadequate System Margin** being superseded by **National Electricity Transmission System Warning - High Risk of Demand Reduction** and vice-versa.
- (c) In circumstances where it is necessary for the period of a **National Electricity Transmission System Warning** to be changed:
  - (i) the period applicable may be extended by the issue of a **National Electricity Transmission System Warning** with a period which follows on from the original period, or
  - (ii) revised or updated **National Electricity Transmission System Warnings** will be issued where there is an overlap with the period specified in an existing **National Electricity Transmission System Warning**, but only if the revised period also includes the full period of the existing **National Electricity Transmission System Warning**.

In any other case the existing **National Electricity Transmission System Warning** will be cancelled and a new one issued.

- (d) A **National Electricity Transmission System Warning** is no longer applicable once the period has passed and to confirm this **NGET** will issue a **Cancellation of National Electricity Transmission System Warning**.

- OC7.5.1 This section of the **Grid Code** deals with **Integral Equipment Tests**. It is designed to provide a framework for the exchange of relevant information and for discussion between **NGET** and certain **Users** in relation to **Integral Equipment Tests**.
- OC7.5.2 An **Integral Equipment Test** :
- (a) is carried out in accordance with the provisions of this OC7.5 at:
    - (i) a **User Site**,
    - (ii) a **Transmission Site**,
    - (iii) an **Embedded Large Power Station**, or,
    - (iv) an **Embedded DC Converter Station**;
  - (b) will normally be undertaken during commissioning or re-commissioning of **Plant** and/or **Apparatus**;
  - (c) may, in the reasonable judgement of the person wishing to perform the test, cause, or have the potential to cause, an **Operational Effect** on a part or parts of the **Total System** but which with prior notice is unlikely to have a materially adverse effect on any part of the **Total System**; and
  - (d) may form part of an agreed programme of work.
- In the case of **OTSUA** operational prior to the **OTSUA Transfer Time**, a **User's Site** or **Transmission Site** shall, for the purposes of this **OC7**, include a site at which there is an **Interface Point** until the **OTSUA Transfer Time** and the provisions of this **OC7.5** and references to **OTSUA** shall be construed and applied accordingly until the **OTSUA Transfer Time**.
- OC7.5.3 A set of guidance notes is available from **NGET** on request, which provide further details on suggested procedures, information flows and responsibilities.
- Notification Of An IET
- OC7.5.4 In order to undertake an **Integral Equipment Test** (and subject to OC7.5.8 below), the **User** or **NGET**, as the case may be, (the proposer) must notify the other (the recipient) of a proposed **IET**. Reasonable advance notification must be given, taking into account the nature of the test and the circumstances which make the test necessary. This will allow recipients time to adequately assess the impact of the **IET** on their **System**.
- OC7.5.5 The notification of the **IET** must normally include the following information:-
- (a) the proposed date and time of the **IET**;
  - (b) the name of the individual and the organisation proposing the **IET**;
  - (c) a proposed programme of testing; and
  - (d) such further detail as the proposer reasonably believes the recipient needs in order to assess the effect the **IET** may have on relevant **Plant** and/or **Apparatus**.
- OC7.5.6 In the case of an **IET** in connection with commissioning or re-commissioning, the test should be incorporated as part of any overall commissioning programme agreed between **NGET** and the **User**.
- Response To Notification Of An IET
- OC7.5.7 The recipient of notification of an **IET** must respond within a reasonable timescale prior to the start time of the **IET** and will not unreasonably withhold or delay acceptance of the **IET** proposal.
- OC7.5.8 (a) Where **NGET** receives notification of a proposed **IET** from a **User**, **NGET** will consult those other **Users** whom it reasonably believes may be affected by the proposed **IET** to seek their views. Information relating to the proposed **IET** may be passed on by **NGET** with the prior agreement of the proposer. However it is not necessary for **NGET** to obtain the agreement of any such **User** as **IETs** should not involve the application of irregular, unusual or extreme conditions. **NGET** may however consider any comments received when deciding whether or not to agree to an **IET**.

- (b) In the case of an **Embedded Large Power Station** or **Embedded DC Converter Station**, the **Generator** or **DC Converter Station** owner as the case may be must liaise with both **NGET** and the relevant **Network Operator**. **NGET** will not agree to an **IET** relating to such **Plant** until the **Generator** or **DC Converter Station** owner has shown that it has the agreement of the relevant **Network Operator**.
- (c) A **Network Operator** will liaise with **NGET** as necessary in those instances where it is aware of an **Embedded Small Power Station** or an **Embedded Medium Power Station** which intends to perform tests which in the reasonable judgement of the **Network Operator** may cause an **Operational Effect** on the **National Electricity Transmission System**.

- OC7.5.9 The response from the recipient, following notification of an **IET** must be one of the following:
- (a) to accept the **IET** proposal;
  - (b) to accept the **IET** proposal conditionally subject to minor modifications such as date and time;
  - (c) not to agree the **IET**, but to suggest alterations to the detail and timing of the **IET** that are necessary to make the **IET** acceptable.

#### Final Confirmation Of An IET

- OC7.5.10 The date and time of an **IET** will be confirmed between **NGET** and the **User**, together with any limitations and restrictions on operation of **Plant** and/or **Apparatus**.
- OC7.5.11 The **IET** may subsequently be amended following discussion and agreement between **NGET** and the **User**.

#### Carrying Out An IET

- OC7.5.12 **IETs** may only take place when agreement has been reached and must be carried out in accordance with the agreed programme of testing.
- OC7.5.13 The implementation of an **IET** will be notified in accordance with OC7.4.5.
- OC7.5.14 Where elements of the programme of testing change during the **IET**, there must be discussion between the appropriate parties to identify whether the **IET** should continue.

### OC7.6 PROCEDURE IN RESPECT OF OPERATIONAL SWITCHING IN SCOTLAND AND OFFSHORE

- OC7.6.1 This section OC7.6 of the **Grid Code** sets out the procedure to be followed for **Operational Switching** in Scotland and **Offshore**. Its provisions are supplementary to the provisions of the rest of this **OC7**.

It is designed to set down the arrangements for **NGET**, **Users** and the **Relevant Transmission Licensees** in respect of the **Operational Switching** of **Plant** and **Apparatus** at a **Connection Site** and parts of the **National Electricity Transmission System** adjacent to that **Connection Site**.

- OC7.6.2 In general:
- (i) **NGET** is responsible for directing the configuration of the **National Electricity Transmission System**
  - (ii) Each **Relevant Transmission Licensee** is responsible for the instruction and operation of its **Plant** and **Apparatus** on its **Transmission System**
  - (iii) Each **User** is responsible for the configuration, instruction and operation of its **Plant** and **Apparatus**.

Definitive schedules of these responsibilities for each **Connection Site** are contained in the relevant **Site Responsibility Schedules**.

For the avoidance of doubt, where a **User** operates **Transmission Plant** and **Apparatus** on behalf of a **Relevant Transmission Licensee**, **NGET** cannot instruct the **User** to operate that **Plant** and **Apparatus**.

#### Planned Operational Switching

OC7.6.3 Following the notification of an **Operation** under OC7.4.5, **NGET** and the **User** shall discuss the **Operational Switching** required. **NGET** will then discuss and agree the details of the **Operational Switching** with the **Relevant Transmission Licensee**. The **Relevant Transmission Licensee** shall then make contact with the **User** to initiate the **Operational Switching**. For the avoidance of doubt, from the time that the **Relevant Transmission Licensee** makes contact with the **User**, the **Relevant Transmission Licensee** shall then become the primary point of operational contact with the **User** in relation to **OC7** for matters which would or could affect, or would or could be affected by the **Operational Switching**.

OC7.6.4 The **User** shall be advised by the **Relevant Transmission Licensee** on the completion of the **Operational Switching**, that **NGET** shall again become the primary point of operational contact for the **User** in relation to **OC7**.

OC7.6.5 During **Operational Switching**, either the **Relevant Transmission Licensee** or the **User** may need to unexpectedly terminate the **Operational Switching**. **NGET** may also need to terminate the **Operational Switching** during the **Operational Switching**. In the event of unexpected termination of the **Operational Switching**, **NGET** shall become the primary point of operational contact for the **User** in relation to **OC7**. Following the termination of the **Operational Switching**, it will not be permitted to restart that **Operational Switching** without the parties again following the process described in OC7.6.3.

#### Emergencies

OC7.6.6 For **Operations** and/or **Events** that present an immediate hazard to the safety of personnel, **Plant** or **Apparatus**, the **Relevant Transmission Licensee** may:

- (i) as permitted by the **STC**, carry out **Operational Switching** of **Plant** and **Apparatus** on its **Transmission System** without reference to **NGET** and the **User**, and
- (ii) request a **User** to carry out **Operational Switching** without the **User** first receiving notification from **NGET**.

In such emergency circumstances, communication between the **Relevant Transmission Licensee** and the **User** shall normally be by telephone and will include an exchange of names. The **User** shall use all reasonable endeavours to carry out **Operational Switching** on its **Plant** and **Apparatus** without delay. Following completion of the requested **Operational Switching**, the **Relevant Transmission Licensee** shall notify **NGET** of the **Operational Switching** which has taken place. In such emergency circumstances, the **User** may only refuse to carry out **Operational Switching** on safety grounds (relating to personnel or plant) and this must be notified to the **Relevant Transmission Licensee** immediately by telephone.

OC7.6.7 For **Operations** and/or **Events** that present an immediate hazard to the safety of personnel, **Plant** or **Apparatus**, and which require **Operational Switching** of **Plant** or **Apparatus** on a **Transmission System** in order to remove the hazard, the **User** should contact the **Relevant Transmission Licensee** directly to request **Operational Switching** of **Plant** or **Apparatus** on its **Transmission System**.

In such emergency circumstances, communication between the **Relevant Transmission Licensee** and the **User** shall normally be by telephone and will include an exchange of names. The **Relevant Transmission Licensee** shall use all reasonable endeavours to carry out **Operational Switching** on its **Plant** and **Apparatus** without delay. Following completion of the requested **Operational Switching**, the **User** shall notify **NGET** of the **Operational Switching** which has taken place. In such emergency circumstances, the **Relevant Transmission Licensee** may only refuse to carry out **Operational Switching** on safety grounds (relating to personnel or plant) and this must be notified to the **User** immediately by telephone.

Establishment Of A Local Switching Procedure

- (a) **NGET**, a **User** or a **Relevant Transmission Licensee** may reasonably require a **Local Switching Procedure** to be established.
- (b) Where the need for a **Local Switching Procedure** arises the following provisions shall apply:
- (i) **NGET**, **User(s)** and the **Relevant Transmission Licensee** will discuss and agree the detail of the **Local Switching Procedure** as soon as the requirement for a **Local Switching Procedure** is identified. **NGET** will notify the **Relevant Transmission Licensee** and the affected **User(s)** and will initiate these discussions.
  - (ii) Each **Local Switching Procedure** shall be in relation to either one or more **Connection Sites** (or in the case of OTSUA operational prior to the OTSUA Transfer Time, Transmission Interface Sites) and parts of the **National Electricity Transmission System** adjacent to the **Connection Site(s)** (or in the case of OTSUA operational prior to the OTSUA Transfer Time, Transmission Interface Sites)
  - (iii) A draft **Local Switching Procedure** shall be prepared by the **Relevant Transmission Licensee** to reflect the agreement reached and shall be sent to **NGET**.
  - (iv) When a **Local Switching Procedure** has been prepared, it shall be sent by **NGET** to the **Relevant Transmission Licensee** and **User(s)** for confirmation of its accuracy.
  - (v) The **Local Switching Procedure** shall then be signed on behalf of **NGET** and on behalf of each **User** and **Relevant Transmission Licensee** by way of written confirmation of its accuracy.
  - (vi) Once agreed under this OC7.6.8, the procedure will become a **Local Switching Procedure** under the **Grid Code**, and (subject to any change pursuant to this OC7) will apply between **NGET**, **Relevant Transmission Licensee** and the relevant **User(s)** as if it were part of the **Grid Code**.
  - (vii) Once signed, **NGET** will send a copy of the **Local Switching Procedure** to the **Relevant Transmission Licensee** and the **User(s)**.
  - (viii) An agreed **Local Switching Procedure** should be referenced by relevant **Site Responsibility Schedules**.
  - (ix) **NGET**, the **User(s)** and the **Relevant Transmission Licensee** must make the **Local Switching Procedure** readily available to the relevant operational staff.
  - (x) If the **Relevant Transmission Licensee** or the **User(s)** become aware that a change is needed to a **Local Switching Procedure**, they must inform **NGET** immediately. Where **NGET** has been informed of a need for a change, or **NGET** proposes a change, **NGET** shall notify both the affected **User** and the **Relevant Transmission Licensee** and will initiate discussions to agree a change to the **Local Switching Procedure**. The principles applying to the establishment of a new **Local Switching Procedure** shall then apply to the discussion and agreement of any changes.



# APPENDIX 1 - NATIONAL ELECTRICITY TRANSMISSION SYSTEM WARNINGS TABLE

| WARNING TYPE   | GRID CODE | FORMAT                                   | TO : FOR ACTION  | TO : FOR INFORMATION                     | TIMESCALE  | WARNING OF/ FOR CONSEQUENCE  | RESPONSE FROM RECIPIENTS  |
|--|-----------|--|--|--|--|--|---|
| NATIONAL ELECTRICITY TRANSMISSION SYSTEM WARNING - Inadequate System Margin      | OC7.4.8.5 | Fax or other electronic means            | Generators, Suppliers, Externally Interconnected System Operators, DC Converter Station owners   | Nework Operators, Non-Embedded Customers | All timescales when at the time there is not a high risk of Demand reduction.<br>Primarily 1200 hours onwards for a future period. | Insufficient generation available to meet forecast Demand plus Operating Margin<br>Notification that if not improved Demand reduction may be instructed.<br>(Normal initial warning of insufficient System Margin)       | Offers of increased availability from Generators or DC Converter Station owners and Interconnector Users.<br>Suppliers notify NGET of any additional Customer Demand Management that they will initiate.  |
| NATIONAL ELECTRICITY TRANSMISSION SYSTEM WARNING - High Risk of Demand Reduction | OC7.4.8.6 | Fax or other electronic means            | Generators, Suppliers, Nework Operators, Non-Embedded Customers, Externally Interconnected System Operators, DC Converter Station owners           |  | All timescales where there is a high risk of Demand reduction.<br>Primarily 1200 hours onwards for a future period.                | Insufficient generation available to meet forecast Demand plus Operating Margin and /or a high risk of Demand reduction being instructed.<br>(May be issued locally as Demand reduction risk only for circuit overloads) | Offers of increased availability from Generators or DC Converter Station owners and Interconnector Users.<br>Suppliers notify NGET of any additional Customer Demand Management that they will initiate.<br>Specified Nework Operators and Non-Embedded Customers to prepare their Demand reduction arrangements and take actions as necessary to enable compliance with NGET instructions that may follow.<br>(Percentages of Demand reduction above 20 % may not be achieved if NGET has not issued the warning by 16.00 hours the previous day). |
| NATIONAL ELECTRICITY TRANSMISSION SYSTEM WARNING - Demand and Control Imminent   | OC7.4.8.7 | Fax/ Telephone or other electronic means | Specified Users only : (to whom an instruction is to be given)<br>Nework Operators, Non-Embedded Customers   | None                                     | Within 30 minutes of anticipated instruction.  | Possibility of Demand reduction within 30 minutes.   | Nework Operators specified to prepare to take action as necessary to enable them to comply with any subsequent NGET instruction for Demand reduction.   |
| NATIONAL ELECTRICITY TRANSMISSION SYSTEM WARNING - Risk of System Disturbance    | OC7.4.8.8 | Fax/ Telephone or other electronic means | Generators, DC Converter Station owners, Nework Operators, Non-Embedded Customers, Externally Interconnected System Operators who may be affected. | Suppliers                                | Control room timescales  | Risk of, or widespread system disturbance to whole or part of the National Electricity Transmission System   | Recipients take steps to warn operational staff and maintain plant or apparatus such that they are best able to withstand the disturbance.  |

^ END OF OPERATING CODE NO. 7 ^

## Grid Code Operating Code No. 8

The following edits shall be made to OC8.3

OC8.3            SCOPE

OC8.3.1        **OC8** applies to **NGET** and to **Users**, which in **OC8** means:

- (a) Generators (including where undertaking OTSDUW);
- (b) **Network Operators**; and
- (c) **Non-Embedded Customers**.

In Scotland and **Offshore OC8** also applies to **Relevant Transmission Licensees**.

The procedures for the establishment of safety co-ordination by **NGET** in relation to **External Interconnections** are set out in **Interconnection Agreements** with relevant persons for the **External Interconnections**.

**OPERATING CODE NO. 8 APPENDIX 1**  
**(OC8A)**

**SAFETY CO-ORDINATION IN RESPECT OF THE E&W TRANSMISSION SYSTEMS OR  
THE SYSTEMS OF E&W USERS**

**CONTENTS**

(This contents page does not form part of the Grid Code)

| <u>Paragraph No/Title</u>  | <u>Page Number</u> |
|--|--------------------|
| OC8A.1 INTRODUCTION .....  | 2                  |
| OC8A.2 OBJECTIVE .....   | 3                  |
| OC8A.3 SCOPE .....   | 4                  |
| OC8A.4 PROCEDURE .....   | 4                  |
| OC8A.4.1 Approval Of Local Safety Instructions.....                                      | 4                  |
| OC8A.4.2 Safety Co-ordinators .....  | 5                  |
| OC8A.4.3 RISSP .....   | 5                  |
| OC8A.5 SAFETY PRECAUTIONS ON HV APPARATUS .....  | 6                  |
| OC8A.5.1 Agreement Of Safety Precautions .....   | 6                  |
| OC8A.5.2 Implementation Of Isolation .....   | 6                  |
| OC8A.5.3 Implementation Of Earthing .....  | 7                  |
| OC8A.5.4 RISSP Issue Procedure .....   | 8                  |
| OC8A.5.5 RISSP Cancellation Procedure.....   | 10                 |
| OC8A.5.6 RISSP Change Control .....  | 10                 |
| OC8A.6 TESTING AFFECTING ANOTHER SAFETY CO-ORDINATOR'S SYSTEM .....                      | 10                 |
| OC8A.7 EMERGENCY SITUATIONS.....   | 11                 |
| OC8A.8 SAFETY PRECAUTIONS RELATING TO WORKING ON EQUIPMENT NEAR TO THE HV<br>SYSTEM..... | 12                 |
| OC8A.8.1 Agreement of Safety Precautions .....   | 12                 |
| OC8A.8.2 Implementation of Isolation and Earthing .....                                  | 12                 |
| OC8A.8.3 Permit For Work For Proximity Work Issue Procedure.....                         | 13                 |
| OC8A.8.4 Permit For Work For Proximity Work Cancellation Procedure .....                 | 13                 |
| OC8A.9 LOSS OF INTEGRITY OF SAFETY PRECAUTIONS.....                                      | 13                 |
| OC8A.10 SAFETY LOG .....   | 13                 |
| APPENDIX A - RISSP-R .....   | 14                 |
| APPENDIX B - RISSP-I.....  | 16                 |
| APPENDIX C- FLOWCHARTS .....   | 18                 |
| APPENDIX C1 - RISSP ISSUE PROCESS .....  | 18                 |
| APPENDIX C2 - TESTING PROCESS .....  | 19                 |
| APPENDIX C3 - RISSP CANCELLATION PROCESS.....  | 20                 |
| APPENDIX C4 - PROCESS FOR WORKING NEAR TO SYSTEM EQUIPMENT .....                         | 21                 |
| APPENDIX D - NATIONAL GRID SAFETY CIRCULAR .....   | 22                 |
| APPENDIX E - FORM OF NGET PERMIT TO WORK .....   | 23                 |

OC8A.1 INTRODUCTION

OC8A.1.1 **OC8A** specifies the standard procedures to be used by the **Relevant E&W Transmission Licensee**, **NGET** (where **NGET** is not the **Relevant E&W Transmission Licensee**) and **Users** for the co-ordination, establishment and maintenance of necessary **Safety Precautions** when work is to be carried out on or near the **E&W Transmission System** or the **System** of an **E&W User** and when there is a need for **Safety Precautions** on **HV Apparatus** on the other's **System** for this work to be carried out safely. **OC8A** applies to **Relevant E&W Transmission Licensees** and **E&W Users** only. Where work is to be carried out on or near equipment on the **Scottish Transmission System** or **Systems** of **Scottish Users**, but such work requires **Safety Precautions** to be established on the **E&W Transmission System** or the **Systems** of **E&W Users**, **OC8A** should be followed by the **Relevant E&W Transmission Licensee** and **E&W Users** to establish the required **Safety Precautions**.

**OC8B** specifies the procedures to be used by the **Relevant Scottish Transmission Licensees** and **Scottish Users**.

In this **OC8A** the term "work" includes testing, other than **System Tests** which are covered by **OC12**.

OC8A.1.2 **OC8A** also covers the co-ordination, establishment and maintenance of necessary safety precautions on the **Implementing Safety Co-ordinator's System** when work is to be carried out at an **E&W User's Site** or a **Transmission Site** (as the case may be) on equipment of the **E&W User** or the **Relevant E&W Transmission Licensee** as the case may be where the work or equipment is near to **HV Apparatus** on the **Implementing Safety Co-ordinator's System**. In the case of **OTSUA**, an **E&W User's Site** or **Transmission Site** shall, for the purposes of this **OC8A**, include a site at which there is a **Transmission Interface Point** until the **OTSUA Transfer Time** and the provisions of this **OC8A** and references to **OTSUA** shall be construed and applied accordingly until the **OTSUA Transfer Time** at which time arrangements in respect of the **Transmission Interface Site** will have been put in place between the **Relevant E&W Transmission Licensee** and the **Offshore Transmission Licensee**.

OC8A.1.3 **OC8A** does not apply to the situation where **Safety Precautions** need to be agreed solely between **E&W Users**. **OC8A** does not apply to the situation where **Safety Precautions** need to be agreed solely between **Transmission Licensees**.

OC8A.1.4 **OC8A** does not seek to impose a particular set of **Safety Rules** on the **Relevant E&W Transmission Licensee** and **E&W Users**; the **Safety Rules** to be adopted and used by the **Relevant E&W Transmission Licensee** and each **E&W User** shall be those chosen by each.

OC8A.1.5 **Site Responsibility Schedules** document the control responsibility for each item of **Plant** and **Apparatus** for each site.

OC8A.1.6 Defined Terms

OC8A.1.6.1 **E&W Users** should bear in mind that in **OC8** only, in order that **OC8** reads more easily with the terminology used in certain **Safety Rules**, the term "**HV Apparatus**" is defined more restrictively and is used accordingly in **OC8A**. **E&W Users** should, therefore, exercise caution in relation to this term when reading and using **OC8A**.

OC8A.1.6.2 In **OC8A** only the following terms shall have the following meanings:

- (1) "**HV Apparatus**" means **High Voltage** electrical circuits forming part of a **System**, on which **Safety From The System** may be required or on which **Safety Precautions** may be applied to allow work to be carried out on a **System**.
- (2) "**Isolation**" means the disconnection of **Apparatus** from the remainder of the **System** in which that **Apparatus** is situated by either of the following:
  - (a) an **Isolating Device** maintained in an isolating position. The isolating position must either be:

- (i) maintained by immobilising and **Locking** the **Isolating Device** in the isolating position and affixing a **Caution Notice** to it. Where the **Isolating Device** is **Locked** with a **Safety Key**, the **Safety Key** must be secured in a **Key Safe** and the **Key Safe Key** must be, where reasonably practicable, given to the authorised site representative of the **Requesting Safety Co-ordinator** and is to be retained in safe custody. Where not reasonably practicable the **Key Safe Key** must be retained by the authorised site representative of the **Implementing Safety Co-ordinator** in safe custody; or
  - (ii) maintained and/or secured by such other method which must be in accordance with the **Local Safety Instructions** of the **Relevant E&W Transmission Licensee** or that **E&W User**, as the case may be; or
- (b) an adequate physical separation which must be in accordance with, and maintained by, the method set out in the **Local Safety Instructions** of the **Relevant E&W Transmission Licensee** or that **E&W User**, as the case may be, and, if it is a part of that method, a **Caution Notice** must be placed at the point of separation;
- or
- (c) in the case where the relevant **HV Apparatus** of the **Implementing Safety Co-ordinator** is being either constructed or modified, an adequate physical separation as a result of a **No System Connection**.
- (3) **"No System Connection"** means an adequate physical separation (which must be in accordance with, and maintained by, the method set out in the **Local Safety Instructions** of the **Implementing Safety Co-ordinator**) of the **Implementing Safety Co-ordinator's HV Apparatus** from the rest of the **Implementing Safety Co-ordinator's System** where such **HV Apparatus** has no installed means of being connected to, and will not for the duration of the **Safety Precaution** be connected to, a source of electrical energy or to any other part of the **Implementing Safety Co-ordinators System**.
- (4) **"Earthing"** means a way of providing a connection between conductors and earth by an **Earthing Device** which is either:
- (i) immobilised and **Locked** in the earthing position. Where the **Earthing Device** is **Locked** with a **Safety Key**, the **Safety Key** must be secured in a **Key Safe** and the **Key Safe Key** must be, where reasonably practicable, given to the authorised site representative of the **Requesting Safety Co-ordinator** and is to be retained in safe custody. Where not reasonably practicable the **Key Safe Key** must be retained by the authorised site representative of the **Implementing Safety Co-ordinator** in safe custody; or
  - (ii) maintained and/or secured in position by such other method which must be in accordance with the **Local Safety Instructions** of the **Relevant E&W Transmission Licensee** or that **E&W User** as the case may be.

OC8A.1.6.3 For the purpose of the co-ordination of safety relating to **HV Apparatus** the term **"Safety Precautions"** means **Isolation** and/or **Earthing**.

## OC8A.2 OBJECTIVE

OC8A.2.1 The objective of **OC8A** is to achieve:-

- (i) **Safety From The System** when work on or near a **System** necessitates the provision of **Safety Precautions** on another **System** on **HV Apparatus** up to a **Connection Point** (or, in the case of OTSUA, Transmission Interface Point); and
- (ii) **Safety From The System** when work is to be carried out at an **E&W User's Site** or a **Transmission Site** (as the case may be) on equipment of the **User** or the **Relevant E&W Transmission Licensee** (as the case may be) where the work or equipment is near to **HV Apparatus** on the **Implementing Safety Co-ordinator's System**.

OC8A.2.2 A flow chart, set out in **OC8A Appendix C**, illustrates the process utilised in **OC8A** to achieve the objective set out in OC8A.2.1. In the case of a conflict between the flow chart and the provisions of the written text of **OC8A**, the written text will prevail.

OC8A.3 SCOPE

OC8A.3.1 **OC8A** applies to the **Relevant E&W Transmission Licensee** and to **E&W Users**, which in OC8A means:

- (a) **Generators** (including where undertaking OTSDUW);
- (b) **Network Operators**; and
- (c) **Non-Embedded Customers**.

The procedures for the establishment of safety co-ordination by the **Relevant E&W Transmission Licensee** in relation to **External Interconnections** are set out in **Interconnection Agreements** with relevant persons for the **External Interconnections**.

OC8A.4 PROCEDURE

OC8A.4.1 Approval Of Local Safety Instructions

- OC8A.4.1.1
- (a) In accordance with the timing requirements of its **Bilateral Agreement**, each **E&W User** will supply to the **Relevant E&W Transmission Licensee** a copy of its **Local Safety Instructions** relating to its side of the **Connection Point** at each **Connection Site**, or in the case of OTSUA a copy of its Local Safety Instructions relating to its side of the Transmission Interface Point at each Transmission Interface Site;
  - (b) In accordance with the timing requirements of each **Bilateral Agreement**, the **Relevant E&W Transmission Licensee** will supply to each **E&W User** a copy of its **Local Safety Instructions** relating to the **Transmission** side of the **Connection Point** at each **Connection Site**, or in the case of OTSUA a copy of its Local Safety Instructions relating to the Transmission side of the Transmission Interface Point at each Transmission Interface Site.
  - (c) Prior to connection the **Relevant E&W Transmission Licensee** and the **E&W User** must have approved each other's relevant **Local Safety Instructions** in relation to **Isolation** and **Earthing**.

OC8A.4.1.2 Either party may require that the **Isolation** and/or **Earthing** provisions in the other party's **Local Safety Instructions** affecting the **Connection Site** (or, in the case of OTSUA, Transmission Interface Site) should be made more stringent in order that approval of the other party's **Local Safety Instructions** can be given. Provided these requirements are not unreasonable, the other party will make such changes as soon as reasonably practicable. These changes may need to cover the application of **Isolation** and/or **Earthing** at a place remote from the **Connection Site** (or, in the case of OTSUA, Transmission Interface Site), depending upon the **System** layout. Approval may not be withheld because the party required to approve reasonably believes the provisions relating to **Isolation** and/or **Earthing** are too stringent.

OC8A.4.1.3 If, following approval, a party wishes to change the provisions in its **Local Safety Instructions** relating to **Isolation** and/or **Earthing**, it must inform the other party. If the change is to make the provisions more stringent, then the other party merely has to note the changes. If the change is to make the provisions less stringent, then the other party needs to approve the new provisions and the procedures referred to in OC8A.4.1.2 apply.

- OC8A.4.2 Safety Co-ordinators
- OC8A.4.2.1 For each **Connection Point** (or, in the case of OTSUA, Transmission Interface Point), the **Relevant E&W Transmission Licensee** and each **E&W User** will at all times have nominated and available a person or persons ("**Safety Co-ordinator(s)**") to be responsible for the co-ordination of **Safety Precautions** when work is to be carried out on a **System** which necessitates the provision of **Safety Precautions** on **HV Apparatus** pursuant to **OC8A**. A **Safety Co-ordinator** may be responsible for the co-ordination of safety on **HV Apparatus** at more than one **Connection Point** (or, in the case of OTSUA, Transmission Interface Point).
- OC8A.4.2.2 Each **Safety Co-ordinator** shall be authorised by the **Relevant E&W Transmission Licensee** or an **E&W User**, as the case may be, as competent to carry out the functions set out in **OC8A** to achieve **Safety From The System**. Confirmation from the **Relevant E&W Transmission Licensee** or an **E&W User**, as the case may be, that its **Safety Co-ordinator(s)** as a group are so authorised is dealt with in CC.5.2. Only persons with such authorisation will carry out the provisions of **OC8A**.
- OC8A.4.2.3 Contact between **Safety Co-ordinators** will be made via normal operational channels, and accordingly separate telephone numbers for **Safety Co-ordinators** need not be provided. At the time of making contact, each party will confirm that they are authorised to act as a **Safety Co-ordinator**, pursuant to **OC8A**.
- OC8A.4.2.4 If work is to be carried out on a **System**, or on equipment of the **Relevant E&W Transmission Licensee** or an **E&W User** near to a **System**, as provided in this **OC8A**, which necessitates the provision of **Safety Precautions** on **HV Apparatus** in accordance with the provisions of **OC8A**, the **Requesting Safety Co-ordinator** who requires the **Safety Precautions** to be provided shall contact the relevant **Implementing Safety Co-ordinator** to co-ordinate the establishment of the **Safety Precautions**.
- OC8A.4.3 RISSP
- OC8A.4.3.1 **OC8A** sets out the procedures for utilising the **RISSP**, which will be used except where dealing with equipment in proximity to the other's **System** as provided in OC8A.8. Sections OC8A.4 to OC8A.7 inclusive should be read accordingly.
- OC8A.4.3.2 The **Relevant E&W Transmission Licensee** will use the format of the **RISSP** forms set out in Appendix A and Appendix B to **OC8A**. That set out in **OC8A** Appendix A and designated as "RISSP-R", shall be used when the **Relevant E&W Transmission Licensee** is the **Requesting Safety Co-ordinator**, and that in **OC8A** Appendix B and designated as "RISSP-I", shall be used when the **Relevant E&W Transmission Licensee** is the **Implementing Safety Co-ordinator**. Proformas of RISSP-R and RISSP-I will be provided for use by the **Relevant E&W Transmission Licensee** staff.
- OC8A.4.3.3 (a) **E&W Users** may either adopt the format referred to in OC8A.4.3.2, or use an equivalent format, provided that it includes sections requiring insertion of the same information and has the same numbering of sections as RISSP-R and RISSP-I as set out in Appendices A and B respectively.
- (b) Whether **E&W Users** adopt the format referred to in OC8A.4.3.2, or use the equivalent format as above, the format may be produced and held in, and retrieved from an electronic form by the **E&W User**.
- (c) Whichever method **E&W Users** choose, each must provide proformas (whether in tangible or electronic form) for use by its staff.
- OC8A.4.3.4 All references to RISSP-R and RISSP-I shall be taken as referring to the corresponding parts of the alternative forms or other tangible written or electronic records used by each **E&W User**.
- OC8A.4.3.5 RISSP-R will have an identifying number written or printed on it, comprising a prefix which identifies the location at which it is issued, and a unique (for each **E&W User** or the **Relevant E&W Transmission Licensee**, as the case may be) serial number which both together uses up to eight characters (including letters and numbers) and the suffix "R".

- OC8A.4.3.6 (a) In accordance with the timing requirements set out in CC.5.2 each **E&W User** shall apply in writing to the **Relevant E&W Transmission Licensee** for the **Relevant E&W Transmission Licensee's** approval of its proposed prefix.
- (b) The **Relevant E&W Transmission Licensee** shall consider the proposed prefix to see if it is the same as (or confusingly similar to) a prefix used by the **Relevant E&W Transmission Licensee** or another **User** and shall, as soon as possible (and in any event within ten days), respond in writing to the **E&W User** with its approval or disapproval.
- (c) If the **Relevant E&W Transmission Licensee** disapproves, it shall explain in its response why it has disapproved and will suggest an alternative prefix.
- (d) If the **Relevant E&W Transmission Licensee** has disapproved, then the **E&W User** shall either notify the **Relevant E&W Transmission Licensee** in writing of its acceptance of the suggested alternative prefix or it shall apply in writing to the **Relevant E&W Transmission Licensee** with revised proposals and the above procedure shall apply to that application.
- OC8A.4.3.7 The prefix allocation will be periodically circulated by **NGET** to all **E&W Users**, for information purposes, using a National Grid Safety Circular in the form set out in **OC8A Appendix D**.

## OC8A.5 SAFETY PRECAUTIONS ON HV APPARATUS

### OC8A.5.1 Agreement Of Safety Precautions

OC8A.5.1.1 The **Requesting Safety Co-ordinator** who requires **Safety Precautions** on another **System(s)** will contact the relevant **Implementing Safety Co-ordinator(s)** to agree the **Location** of the **Safety Precautions** to be established. This agreement will be recorded in the respective **Safety Logs**.

OC8A.5.1.2 It is the responsibility of the **Implementing Safety Co-ordinator** to ensure that adequate **Safety Precautions** are established and maintained, on his and/or another **System** connected to his **System**, to enable **Safety From The System** to be achieved on the **HV Apparatus**, specified by the **Requesting Safety Co-ordinator** which is to be identified in Part 1.1 of the **RISSP**. Reference to another **System** in this OC8A.5.1.2 shall not include the **Requesting Safety Co-ordinator's System** which is dealt with in OC8A.5.1.3.

OC8A.5.1.3 When the **Implementing Safety Co-ordinator** is of the reasonable opinion that it is necessary for **Safety Precautions** on the **System** of the **Requesting Safety Co-ordinator**, other than on the **HV Apparatus** specified by the **Requesting Safety Co-ordinator**, which is to be identified in Part 1.1 of the **RISSP**, he shall contact the **Requesting Safety Co-ordinator** and the details shall be recorded in part 1.1 of the **RISSP** forms. In these circumstances it is the responsibility of the **Requesting Safety Co-ordinator** to establish and maintain such **Safety Precautions**.

### OC8A.5.1.4 In The Event Of Disagreement

In any case where the **Requesting Safety Co-ordinator** and the **Implementing Safety Co-ordinator** are unable to agree the **Location** of the **Isolation** and (if requested) **Earthing**, both shall be at the closest available points on the infeeds to the **HV Apparatus** on which **Safety From The System** is to be achieved as indicated on the **Operation Diagram**.

### OC8A.5.2 Implementation Of Isolation

OC8A.5.2.1 Following the agreement of the **Safety Precautions** in accordance with OC8A.5.1 the **Implementing Safety Co-ordinator** shall then establish the agreed **Isolation**.



OC8A.5.2.2 The **Implementing Safety Co-ordinator** shall confirm to the **Requesting Safety Co-ordinator** that the agreed **Isolation** has been established, and identify the **Requesting Safety Co-ordinator's HV Apparatus** up to the **Connection Point** (or, in the case of OTSUA, Transmission Interface Point), for which the **Isolation** has been provided. The confirmation shall specify:

- (a) for each **Location**, the identity (by means of **HV Apparatus** name, nomenclature and numbering or position, as applicable) of each point of **Isolation**;
- (b) whether **Isolation** has been achieved by an **Isolating Device** in the isolating position, by an adequate physical separation or as a result of a **No System Connection**;
- (c) where an **Isolating Device** has been used whether the isolating position is either:
  - (i) maintained by immobilising and **Locking** the **Isolating Device** in the isolating position and affixing a **Caution Notice** to it. Where the **Isolating Device** has been **Locked** with a **Safety Key**, the confirmation shall specify that the **Safety Key** has been secured in a **Key Safe** and the **Key Safe Key** has been given to the authorised site representative of the **Requesting Safety Co-ordinator** where reasonably practicable and is to be retained in safe custody. Where not reasonably practicable (including where **Earthing** has been requested in OC8A.5.1), the confirmation shall specify that the **Key Safe Key** will be retained by the authorised site representative of the **Implementing Safety Co-ordinator** in safe custody; or
  - (ii) maintained and/or secured by such other method which must be in accordance with the **Local Safety Instructions** of the **Relevant E&W Transmission Licensee** or that **E&W User**, as the case may be; and
- (d) where an adequate physical separation has been used that it will be in accordance with, and maintained by, the method set out in the **Local Safety Instructions** of the **Relevant E&W Transmission Licensee** or that **E&W User**, as the case may be, and, if it is a part of that method, that a **Caution Notice** has been placed at the point of separation;
- (e) where a **No System Connection** has been used the physical position of the **No System Connection** shall be defined and shall not be varied for the duration of **Safety Precaution** and the **Implementing Safety Co-ordinator's** relevant **HV Apparatus** will not, for the duration of the **Safety Precaution** be connected to a source of electrical energy or to any other part of the **Implementing Safety Co-ordinator's System**.

The confirmation of **Isolation** shall be recorded in the respective **Safety Logs**.

OC8A.5.2.3 Following the confirmation of **Isolation** being established by the **Implementing Safety Co-ordinator** and the necessary establishment of relevant **Isolation** on the **Requesting Safety Co-ordinators System**, the **Requesting Safety Co-ordinator** will then request the implementation of **Earthing** by the **Implementing Safety Co-ordinator**, if agreed in section OC8A.5.1. If the implementation of **Earthing** has been agreed, then the authorised site representative of the **Implementing Safety Co-ordinator** shall retain any **Key Safe Key** in safe custody until any **Safety Key** used for **Earthing** has been secured in the **Key Safe**.

OC8A.5.3 Implementation Of Earthing

OC8A.5.3.1 The **Implementing Safety Co-ordinator** shall then establish the agreed **Earthing**.

OC8A.5.3.2 The **Implementing Safety Co-ordinator** shall confirm to the **Requesting Safety Co-ordinator** that the agreed **Earthing** has been established, and identify the **Requesting Safety Co-ordinator's HV Apparatus** up to the **Connection Point** (or, in the case of OTSUA, Transmission Interface Point), for which the **Earthing** has been provided. The confirmation shall specify:

- (a) for each **Location**, the identity (by means of **HV Apparatus** name, nomenclature and numbering or position, as is applicable) of each point of **Earthing**; and
- (b) in respect of the **Earthing Device** used, whether it is:
  - (i) immobilised and **Locked** in the earthing position. Where the **Earthing Device** has

been **Locked** with a **Safety Key**, that the **Safety Key** has been secured in a **Key Safe** and the **Key Safe Key** has been given to the authorised site representative of the **Requesting Safety Co-ordinator** where reasonably practicable and is to be retained in safe custody. Where not reasonably practicable, that the **Key Safe Key** will be retained by the authorised site representative of the **Implementing Safety Co-ordinator** in safe custody; or

- (ii) maintained and/or secured in position by such other method which is in accordance with the **Local Safety Instructions** of the **Relevant E&W Transmission Licensee** or the **Relevant Transmission Licensee** or that **E&W User**, as the case may be.

The confirmation of **Earthing** shall be recorded in the respective **Safety Logs**.

- OC8A.5.3.3. The **Implementing Safety Co-ordinator** shall ensure that the established **Safety Precautions** are maintained until requested to be removed by the relevant **Requesting Safety Co-ordinator**.
- OC8A.5.3.4 Certain designs of gas insulated switchgear three position isolator and earth switches specifically provide a combined **Isolation** and **Earthing** function within a single mechanism contained within a single integral unit. Where **Safety Precautions** are required across control boundaries and subject to the requirements of OC8A.5.1, it is permissible to earth before **Points of Isolation** have been established provided that all interconnected circuits are fully disconnected from live **HV Apparatus**.
- OC8A.5.4 RISSP Issue Procedure
- OC8A.5.4.1 Where **Safety Precautions** on another **System(s)** are being provided to enable work on the **Requesting Safety Co-ordinator's System**, before any work commences they must be recorded by a **RISSP** being issued. The **RISSP** is applicable to **HV Apparatus** up to the **Connection Point** (or, in the case of OTSUA, Transmission Interface Point) identified in section 1.1 of the **RISSP-R** and **RISSP-I** forms.
- OC8A.5.4.2 Where **Safety Precautions** are being provided to enable work to be carried out on both sides of the **Connection Point** (or, in the case of OTSUA, Transmission Interface Point) a **RISSP** will need to be issued for each side of the **Connection Point** (or, in the case of OTSUA, Transmission Interface Point) with the **Relevant E&W Transmission Licensee** and the respective **User** each enacting the role of **Requesting Safety Co-ordinator**. This will result in a **RISSP-R** and a **RISSP-I** form being completed by each of the **Relevant E&W Transmission Licensee** and the **E&W User**, with each **Requesting Safety Co-ordinator** issuing a separate **RISSP** number.
- OC8A.5.4.3 Once the **Safety Precautions** have been established (in accordance with OC8A.5.2 and OC8A.5.3), the **Implementing Safety Co-ordinator** shall complete parts 1.1 and 1.2 of a **RISSP-I** form recording the details specified in OC8A.5.1.3, OC8A.5.2.2 and OC8A.5.3.2. Where **Earthing** has not been requested, Part 1.2(b) will be completed with the words "not applicable" or "N/A". He shall then contact the **Requesting Safety Co-ordinator** to pass on these details.
- OC8A.5.4.4 The **Requesting Safety Co-ordinator** shall complete Parts 1.1 and 1.2 of the **RISSP-R**, making a precise copy of the details received. On completion, the **Requesting Safety Co-ordinator** shall read the entries made back to the sender and check that an accurate copy has been made.
- OC8A.5.4.5 The **Requesting Safety Co-ordinator** shall then issue the number of the **RISSP**, taken from the **RISSP-R**, to the **Implementing Safety Co-ordinator** who will ensure that the number, including the prefix and suffix, is accurately recorded in the designated space on the **RISSP-I** form.
- OC8A.5.4.6 The **Requesting Safety Co-ordinator** and the **Implementing Safety Co-ordinator** shall complete and sign Part 1.3 of the **RISSP-R** and **RISSP-I** respectively and then enter the time and date. When signed no alteration to the **RISSP** is permitted; the **RISSP** may only be cancelled.

OC8A.5.4.7 The **Requesting Safety Co-ordinator** is then free to authorise work (including a test that does not affect the **Implementing Safety Co-ordinator's System**) in accordance with the requirements of the relevant internal safety procedures which apply to the **Requesting Safety Co-ordinator's System**. This is likely to involve the issue of safety documents or other relevant internal authorisations. Where testing is to be carried out which affects the **Implementing Safety Co-ordinator's System**, the procedure set out below in OC8A.6 shall be implemented.

OC8A.5.5 RISSP Cancellation Procedure

OC8A.5.5.1 When the **Requesting Safety Co-ordinator** decides that **Safety Precautions** are no longer required, he will contact the relevant **Implementing Safety Co-ordinator** to effect cancellation of the associated **RISSP**.

OC8A.5.5.2 The **Requesting Safety Co-ordinator** will inform the relevant **Implementing Safety Co-ordinator** of the **RISSP** identifying number (including the prefix and suffix), and agree it is the **RISSP** to be cancelled.

OC8A.5.5.3 The **Requesting Safety Co-ordinator** and the relevant **Implementing Safety Co-ordinator** shall then respectively complete Part 2.1 of their respective **RISSP-R** and **RISSP-I** forms and shall then exchange details. The details being exchanged shall include their respective names and time and date. On completion of the exchange of details the respective **RISSP** is cancelled. The removal of **Safety Precautions** is as set out in OC8A.5.5.4 and OC8A.5.5.5.

OC8A.5.5.4 Neither **Safety Co-ordinator** shall instruct the removal of any **Isolation** forming part of the **Safety Precautions** as part of the returning of the **HV Apparatus** to service until it is confirmed to each by each other that every earth on each side of the **Connection Point** (or, in the case of OTSUA, Transmission Interface Point), within the points of isolation identified on the **RISSP**, has been removed or disconnected by the provision of additional **Points of Isolation**.

OC8A.5.5.5 Subject to the provisions in OC8A.5.5.4, the **Implementing Safety Co-ordinator** is then free to arrange the removal of the **Safety Precautions**, the procedure to achieve that being entirely an internal matter for the party the **Implementing Safety Co-ordinator** is representing. Where a **Key Safe Key** has been given to the authorised site representative of the **Requesting Safety Co-ordinator**, the **Key Safe Key** must be returned to the authorised site representative of the **Implementing Safety Co-ordinator**. The only situation in which any **Safety Precautions** may be removed without first cancelling the **RISSP** in accordance with OC8A.5.5 or OC8A.5.6 is when **Earthing** is removed in the situation envisaged in OC8A.6.2(b).

OC8A.5.6 RISSP Change Control

Nothing in this **OC8A** prevents the **Relevant E&W Transmission Licensee** and **E&W Users** agreeing to a simultaneous cancellation and issue of a new **RISSP**, if both agree. It should be noted, however, that the effect of that under the relevant **Safety Rules** is not a matter with which the **Grid Code** deals.

OC8A.6 TESTING AFFECTING ANOTHER SAFETY CO-ORDINATOR'S SYSTEM

OC8A.6.1 The carrying out of the test may affect **Safety Precautions** on **RISSPs** or work being carried out which does not require a **RISSP**. Testing can, for example, include the application of an independent test voltage. Accordingly, where the **Requesting Safety Co-ordinator** wishes to authorise the carrying out of such a test to which the procedures in OC8A.6 apply he may not do so and the test will not take place unless and until the steps in (a)-(c) below have been followed and confirmation of completion has been recorded in the respective **Safety Logs**:

- (a) confirmation must be obtained from the **Implementing Safety Co-ordinator** that:
  - (i) no person is working on, or testing, or has been authorised to work on, or test, any part of its **System** or another **System(s)** (other than the **System** of the **Requesting Safety Co-ordinator**) within the points of **Isolation** identified on the **RISSP** form relating to the test which is proposed to be undertaken, and
  - (ii) no person will be so authorised until the proposed test has been completed (or cancelled) and the **Requesting Safety Co-ordinator** has notified the **Implementing Safety Co-ordinator** of its completion (or cancellation);
- (b) any other current **RISSPs** which relate to the parts of the **System** in which the testing is to take place must have been cancelled in accordance with procedures set out in OC8A.5.5;

- (c) the **Implementing Safety Co-ordinator** must agree with the **Requesting Safety Co-ordinator** to permit the testing on that part of the **System** between the points of **Isolation** identified in the **RISSP** associated with the test and the points of **Isolation** on the **Requesting Safety Co-ordinator's System**.
- OC8A.6.2 (a) The **Requesting Safety Co-ordinator** will inform the **Implementing Safety Co-ordinator** as soon as the test has been completed or cancelled and the confirmation shall be recorded in the respective **Safety Logs**.
- (b) When the test gives rise to the removal of **Earthing** which it is not intended to re-apply, the relevant **RISSP** associated with the test shall be cancelled at the completion or cancellation of the test in accordance with the procedure set out in either OC8A.5.5 or OC8A.5.6. Where the **Earthing** is re-applied following the completion or cancellation of the test, there is no requirement to cancel the relevant **RISSP** associated with the test pursuant to this OC8A.6.2.
- OC8A.7 **EMERGENCY SITUATIONS**
- OC8A.7.1 There may be circumstances where **Safety Precautions** need to be established in relation to an unintended electrical connection or situations where there is an unintended risk of electrical connection between the **National Electricity Transmission System** and an **E&W User's System**, for example resulting from an incident where one line becomes attached or unacceptably close to another.
- OC8A.7.2 In those circumstances, if both the **Relevant E&W Transmission Licensee** and the respective **E&W User** agree, the relevant provisions of OC8A.5 will apply as if the electrical connections or potential connections were, solely for the purposes of this **OC8A**, a **Connection Point** (or, in the case of OTSUA, Transmission Interface Point).
- OC8A.7.3 (a) The relevant **Safety Co-ordinator** shall be that for the electrically closest existing **Connection Point** (or, in the case of OTSUA, Transmission Interface Point) to that **E&W User's System** or such other local **Connection Point** (or, in the case of OTSUA, Transmission Interface Point) as may be agreed between the **Relevant E&W Transmission Licensee** and the **E&W User**, with discussions taking place between the relevant local **Safety Co-ordinators**. The **Connection Point** (or, in the case of OTSUA, Transmission Interface Point) to be used shall be known in this OC8A.7.3 as the "relevant **Connection Point**" (or, in the case of OTSUA, "relevant Transmission Interface Point").
- (b) The **Local Safety Instructions** shall be those which apply to the relevant **Connection Point** (or, in the case of OTSUA, Transmission Interface Point).
- (c) The prefix for the **RISSP** will be that which applies for the relevant **Connection Point** (or, in the case of OTSUA, Transmission Interface Point).

- OC8A.8 SAFETY PRECAUTIONS RELATING TO WORKING ON EQUIPMENT NEAR TO THE HV SYSTEM
- OC8A.8 applies to the situation where work is to be carried out at an **E&W User's Site** or a **Transmission Site** (as the case may be) on equipment of the **User** or the **Relevant E&W Transmission Licensee** as the case may be, where the work or equipment is near to **HV Apparatus** on the **Implementing Safety Co-ordinator's System**. It does not apply to other situations to which **OC8A** applies. In this part of **OC8A**, a **Permit for Work for proximity work** is to be used, rather than the usual **RISSP** procedure, given the nature and effect of the work, all as further provided in the OC8A.8.
- OC8A.8.1 Agreement Of Safety Precautions
- OC8A.8.1.1 The **Requesting Safety Co-ordinator** who requires **Safety Precautions** on another **System(s)** when work is to be carried out at an **E&W User's Site** or a **Transmission Site** (as the case may be) on equipment of the **User** or the **Relevant E&W Transmission Licensee**, as the case may be, where the work or equipment is near to **HV Apparatus** on the **Implementing Safety Co-ordinator's System** will contact the relevant **Implementing Safety Co-ordinator(s)** to agree the Location of the **Safety Precautions** to be established, having as part of this process informed the **Implementing Safety Co-ordinator** of the equipment and the work to be undertaken. The respective **Safety Co-ordinators** will ensure that they discuss the request with their authorised site representative and that the respective authorised site representatives discuss the request at the **Connection Site (or, in the case of OTSUA, Transmission Interface Site)**. This agreement will be recorded in the respective **Safety Logs**.
- OC8A.8.1.2 It is the responsibility of the **Implementing Safety Co-ordinator**, working with his authorised site representative as appropriate, to ensure that adequate **Safety Precautions** are established and maintained, on his and/or another **System** connected to his **System**, to enable **Safety From The System** to be achieved for work to be carried out at an **E&W User's Site** or a **Transmission Site** (as the case may be) on equipment and in relation to work which is to be identified in the relevant part of the **Permit for Work for proximity work** where the work or equipment is near to **HV Apparatus** of the **Implementing Safety Co-ordinator's System** specified by the **Requesting Safety Co-ordinator**. Reference to another **System** in this OC8A.8.1.2 shall not include the **Requesting Safety Co-ordinator's System**.
- OC8A.8.1.3 In The Event Of Disagreement
- In any case where the **Requesting Safety Co-ordinator** and the **Implementing Safety Co-ordinator** are unable to agree the **Location** of the **Isolation** and (if requested) **Earthing**, both shall be at the closest available points on the infeeds to the **HV Apparatus** near to which the work is to be carried out as indicated on the **Operation Diagram**.
- OC8A.8.2 Implementation Of Isolation And Earthing
- OC8A.8.2.1 Following the agreement of the **Safety Precautions** in accordance with OC8A.8.1 the **Implementing Safety Co-ordinator** shall then establish the agreed **Isolation** and (if required) **Earthing**.
- OC8A.8.2.2 The **Implementing Safety Co-ordinator** shall confirm to the **Requesting Safety Co-ordinator** that the agreed **Isolation** and (if required) **Earthing** has been established.
- OC8A.8.2.3 The **Implementing Safety Co-ordinator** shall ensure that the established **Safety Precautions** are maintained until requested to be removed by the relevant **Requesting Safety Co-ordinator**.

- OC8A.8.3 Permit For Work For Proximity Work Issue Procedure
- OC8A.8.3.1 Where **Safety Precautions** on another **System(s)** are being provided to enable work to be carried out at an **E&W User's Site** or **Transmission Site** (as the case may be) on equipment where the work or equipment is in proximity to **HV Apparatus** of the **Implementing Safety Co-ordinator**, before any work commences they must be recorded by a **Permit for Work for proximity work** being issued. The **Permit for Work for proximity work** shall identify the **Implementing Safety Co-ordinator's HV Apparatus** in proximity to the required work.
- OC8A.8.3.2 Once the **Safety Precautions** have been established (in accordance with OC8A.8.2), the **Implementing Safety Co-ordinator** shall agree to the issue of the **Permit for Work for proximity work** with the appropriately authorised site representative of the **Requesting Safety Co-ordinator's Site**. The **Implementing Safety Co-ordinator** will inform the **Requesting Safety Co-ordinator** of the **Permit for Work for proximity work** identifying number.
- OC8A.8.3.3 The appropriately authorised site representative of the **Implementing Safety Co-ordinator** shall then issue the **Permit for Work for proximity work** to the appropriately authorised site representative of the **Requesting Safety Co-ordinator**. The **Permit for Work for proximity work** will in the section dealing with the work to be carried out, be completed to identify that the work is near the **Implementing Safety Co-ordinator's HV Apparatus**. No further details of the **Requesting Safety Co-ordinator's** work will be recorded, as that is a matter for the **Requesting Safety Co-ordinator** in relation to his work.
- OC8A.8.3.4 The **Requesting Safety Co-ordinator** is then free to authorise work in accordance with the requirements of the relevant internal safety procedures which apply to the **Requesting Safety Co-ordinator's Site**. This is likely to involve the issue of safety documents or other relevant internal authorisations.
- OC8A.8.4 Permit For Work For Proximity Work Cancellation Procedure
- OC8A.8.4.1 When the **Requesting Safety Co-ordinator** decides that **Safety Precautions** are no longer required, he will contact the relevant **Implementing Safety Co-ordinator** to effect cancellation of the associated **Permit for Work for proximity work**.
- OC8A.8.4.2 The **Requesting Safety Co-ordinator** will inform the relevant **Implementing Safety Co-ordinator** of the **Permit for Work for proximity work** identifying number, and agree that the **Permit for Work for proximity work** can be cancelled. The cancellation is then effected by the appropriately authorised site representative of the **Requesting Safety Co-ordinator** returning the **Permit for Work for proximity work** to the appropriately authorised site representative of the **Implementing Safety Co-ordinator**.
- OC8A.8.4.3 The **Implementing Safety Co-ordinator** is then free to arrange the removal of the **Safety Precautions**, the procedure to achieve that being entirely an internal matter for the party the **Implementing Safety Co-ordinator** is representing.
- OC8A.9 LOSS OF INTEGRITY OF SAFETY PRECAUTIONS
- OC8A.9.1 In any instance when any **Safety Precautions** may be ineffective for any reason the relevant **Safety Co-ordinator** shall inform the other **Safety Co-ordinator(s)** without delay of that being the case and, if requested, of the reasons why.
- OC8A.10 SAFETY LOG
- OC8A.10.1 The **Relevant E&W Transmission Licensee** and **E&W Users** shall maintain **Safety Logs** which shall be a chronological record of all messages relating to safety co-ordination under **OC8A** sent and received by the **Safety Co-ordinator(s)**. The **Safety Logs** must be retained for a period of not less than one year.

# APPENDIX A - RISSP-R

[the Relevant E&W Transmission Licensee]

[\_\_\_\_\_ CONTROL CENTRE/SITE]

## RECORD OF INTER-SYSTEM SAFETY PRECAUTIONS (RISSP-R) (Requesting Safety Co-ordinator's Record)

RISSP NUMBER

|  |
|--|
|  |
|--|

### PART 1

#### 1.1 HV APPARATUS IDENTIFICATION

**Safety Precautions** have been established by the **Implementing Safety Co-ordinator** (or by another **User** on that **User's System** connected to the **Implementing Safety Co-ordinator's System**) to achieve (in so far as it is possible from that side of the **Connection Point/Transmission Interface Point**) **Safety From The System** on the following **HV Apparatus** on the **Requesting Safety Co-ordinator's System**: [State identity - name(s) and, where applicable, identification of the **HV** circuit(s) up to the **Connection Point/Transmission Interface Point**]:

\_\_\_\_\_

Further **Safety precautions** required on the **Requesting Safety Co-ordinator's System** as notified by the **Implementing Safety Co-ordinator**.

\_\_\_\_\_

#### 1.2 SAFETY PRECAUTIONS ESTABLISHED

##### (a) ISOLATION

[State the **Location(s)** at which **Isolation** has been established (whether on the **Implementing Safety Co-ordinator's System** or on the **System** of another **User** connected to the **Implementing Safety Co-ordinator's System**). For each **Location**, identify each point of **Isolation**. For each point of **Isolation**, state the means by which the **Isolation** has been achieved, and whether, immobilised and **Locked**, **Caution Notice** affixed, other safety procedures applied, as appropriate.]

\_\_\_\_\_

\_\_\_\_\_

\_\_\_\_\_

##### (b) EARTHING

[State the **Location(s)** at which **Earthing** has been established (whether on the **Implementing Safety Co-ordinator's System** or on the **System** of another **User** connected to the **Implementing Safety Co-ordinator's System**). For each **Location**, identify each point of **Earthing**. For each point of **Earthing**, state the means by which **Earthing** has been achieved, and whether, immobilised and **Locked**, other safety procedures applied, as appropriate].

\_\_\_\_\_

\_\_\_\_\_

\_\_\_\_\_

#### 1.3 ISSUE

I have received confirmation from \_\_\_\_\_ (name of **Implementing Safety Co-ordinator**) at \_\_\_\_\_ (location) that the **Safety Precautions** identified in paragraph 1.2 have been established and that instructions will not be issued at his location for their removal until this **RISSP** is cancelled.

Signed .....(Requesting Safety Co-ordinator)

at .....(time) on ..... (Date)



PART 2

2.1 CANCELLATION

I have confirmed to \_\_\_\_\_ (name of the **Implementing Safety Co-ordinator**) at \_\_\_\_\_ (location) that the **Safety Precautions** set out in paragraph 1.2 are no longer required and accordingly the **RISSP** is cancelled.

Signed .....(**Requesting Safety Co-ordinator**)

at .....(time) on ..... (Date)

# APPENDIX B - RISSP-I

[the Relevant E&W Transmission Licensee]

[\_\_\_\_\_ CONTROL CENTRE/SITE]

## RECORD OF INTER-SYSTEM SAFETY PRECAUTIONS (RISSP-I) (Implementing Safety Co-ordinator's Record)

PART 1

RISSP NUMBER

### 1.1 HV APPARATUS IDENTIFICATION

**Safety Precautions** have been established by the **Implementing Safety Co-ordinator** (or by another **User** on that **User's System** connected to the **Implementing Safety Co-ordinator's System**) to achieve (in so far as it is possible from that side of the **Connection Point/Transmission Interface Point**) **Safety From The System** on the following **HV Apparatus** on the **Requesting Safety Co-ordinator's System**: [State identity - name(s) and, where applicable, identification of the **HV** circuit(s) up to the **Connection Point/Transmission Interface Point**]:

---

---

Recording of notification given to the **Requesting Safety Co-ordinator** concerning further **Safety Precautions** required on the **Requesting Safety Co-ordinator's System**.

### 1.2 SAFETY PRECAUTIONS ESTABLISHED

#### (a) ISOLATION

[State the **Location(s)** at which **Isolation** has been established (whether on the **Implementing Safety Co-ordinator's System** or on the **System** of another **User** connected to the **Implementing Safety Co-ordinator's System**). For each **Location**, identify each point of **Isolation**. For each point of **Isolation**, state the means by which the **Isolation** has been achieved, and whether, immobilised and **Locked**, **Caution Notice** affixed, other safety procedures applied, as appropriate.]

---

---

---

#### (b) EARTHING

[State the **Location(s)** at which **Earthing** has been established (whether on the **Implementing Safety Co-ordinator's System** or on the **System** of another **User** connected to the **Implementing Safety Co-ordinator's System**). For each **Location**, identify each point of **Earthing**. For each point of **Earthing**, state the means by which **Earthing** has been achieved, and whether, immobilised and **Locked**, other safety procedures applied, as appropriate].

---

---

---

### 1.3 ISSUE

I have confirmed to \_\_\_\_\_ (name of **Requesting Safety Co-ordinator**) at \_\_\_\_\_ (location) that the **Safety Precautions** identified in paragraph 1.2 have been established and that instructions will not be issued at my location for their removal until this **RISSP** is cancelled.

Signed .....(**Implementing Safety Co-ordinator**)

at .....(time) on ..... (Date)

PART 2

2.1 CANCELLATION

I have received confirmation from \_\_\_\_\_ (name of the **Requesting Safety Co-ordinator**) at \_\_\_\_\_ (location) that the **Safety Precautions** set out in paragraph 1.2 are no longer required and accordingly the **RISSP** is cancelled.

Signed .....(**Implementing Safety Co-ordinator**)

at .....(time) on ..... (Date)

(Note: This form to be of a different colour from RISSP-R)

# APPENDIX C - FLOWCHARTS

## APPENDIX C1 - RISSP ISSUE PROCESS

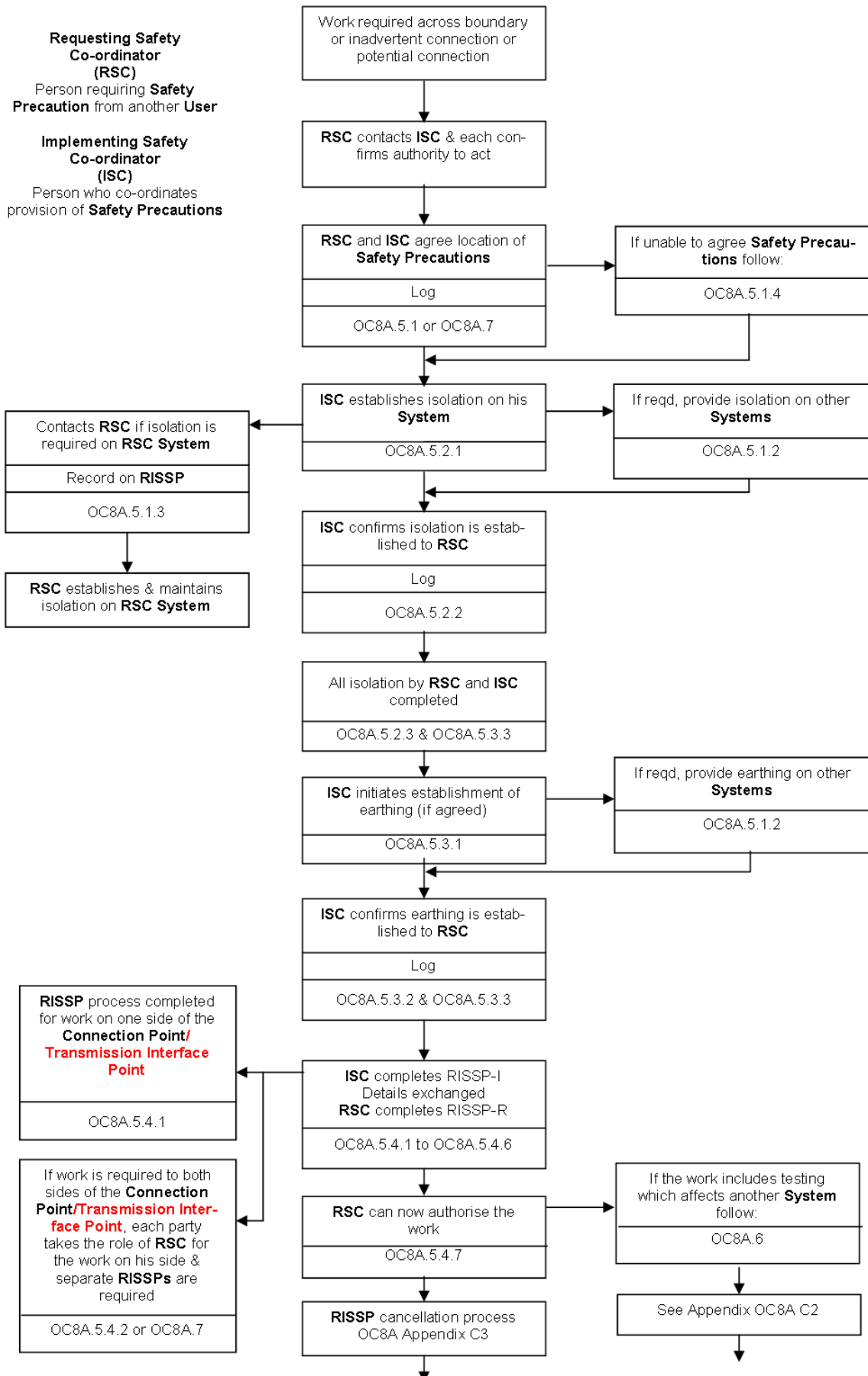

## APPENDIX C2 - TESTING PROCESS

**Where testing affects another Safety Co-ordinator's System**

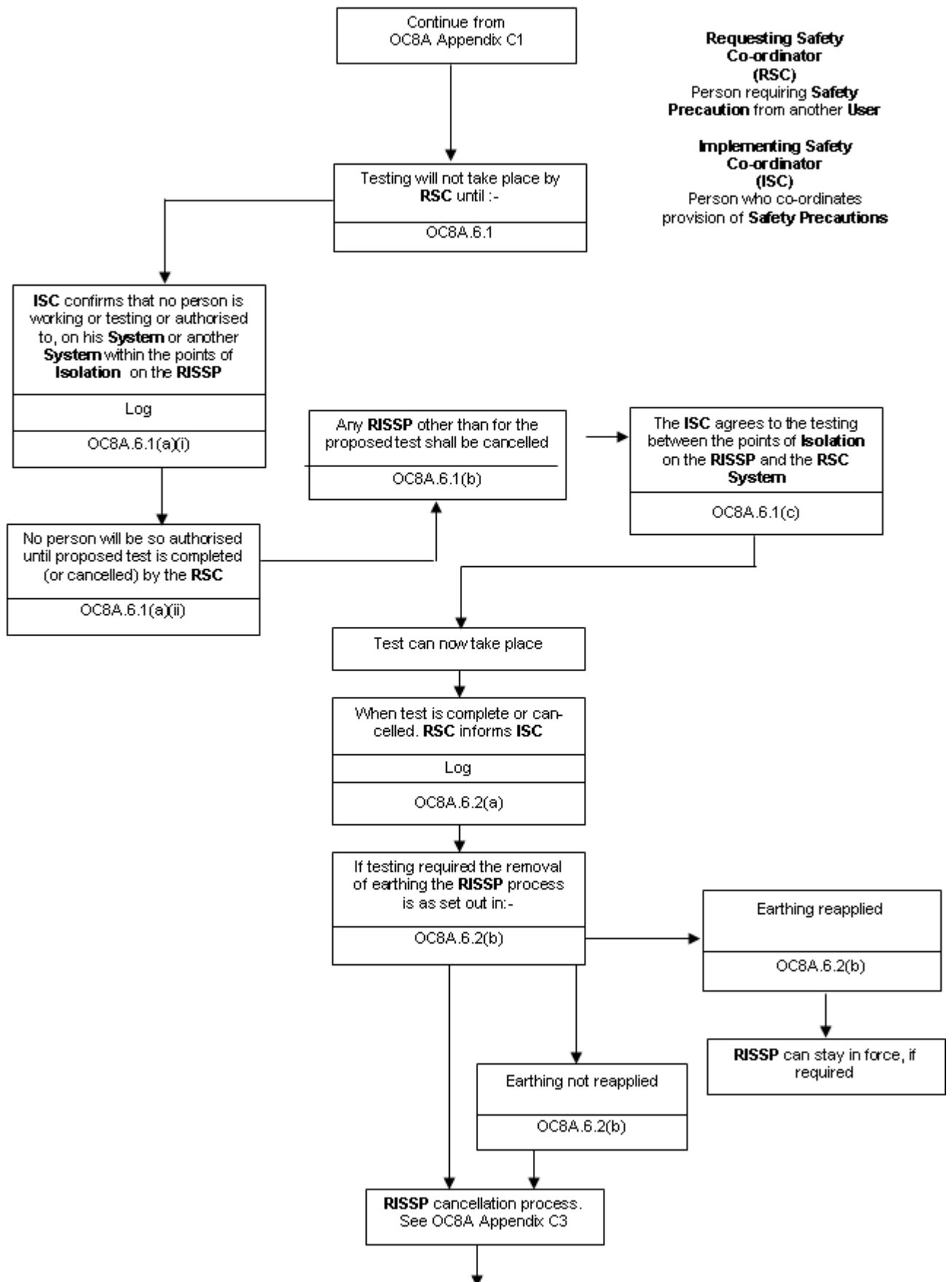

**Requesting Safety Co-ordinator (RSC)**  
Person requiring Safety Precaution from another User

**Implementing Safety Co-ordinator (ISC)**  
Person who co-ordinates provision of Safety Precautions

## APPENDIX C3 - RISSP CANCELLATION PROCESS

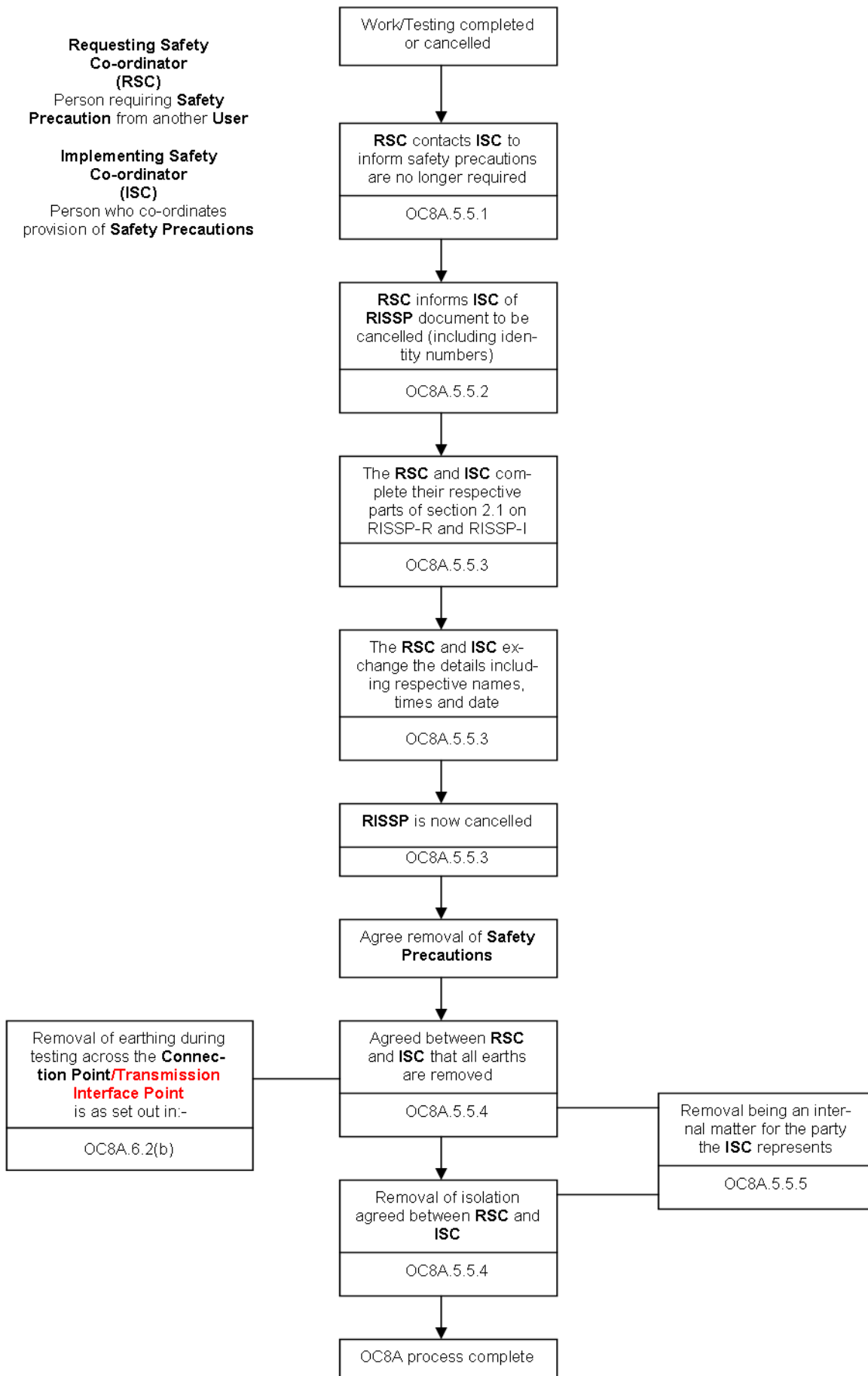

# APPENDIX C4 - PROCESS FOR WORKING NEAR TO SYSTEM EQUIPMENT

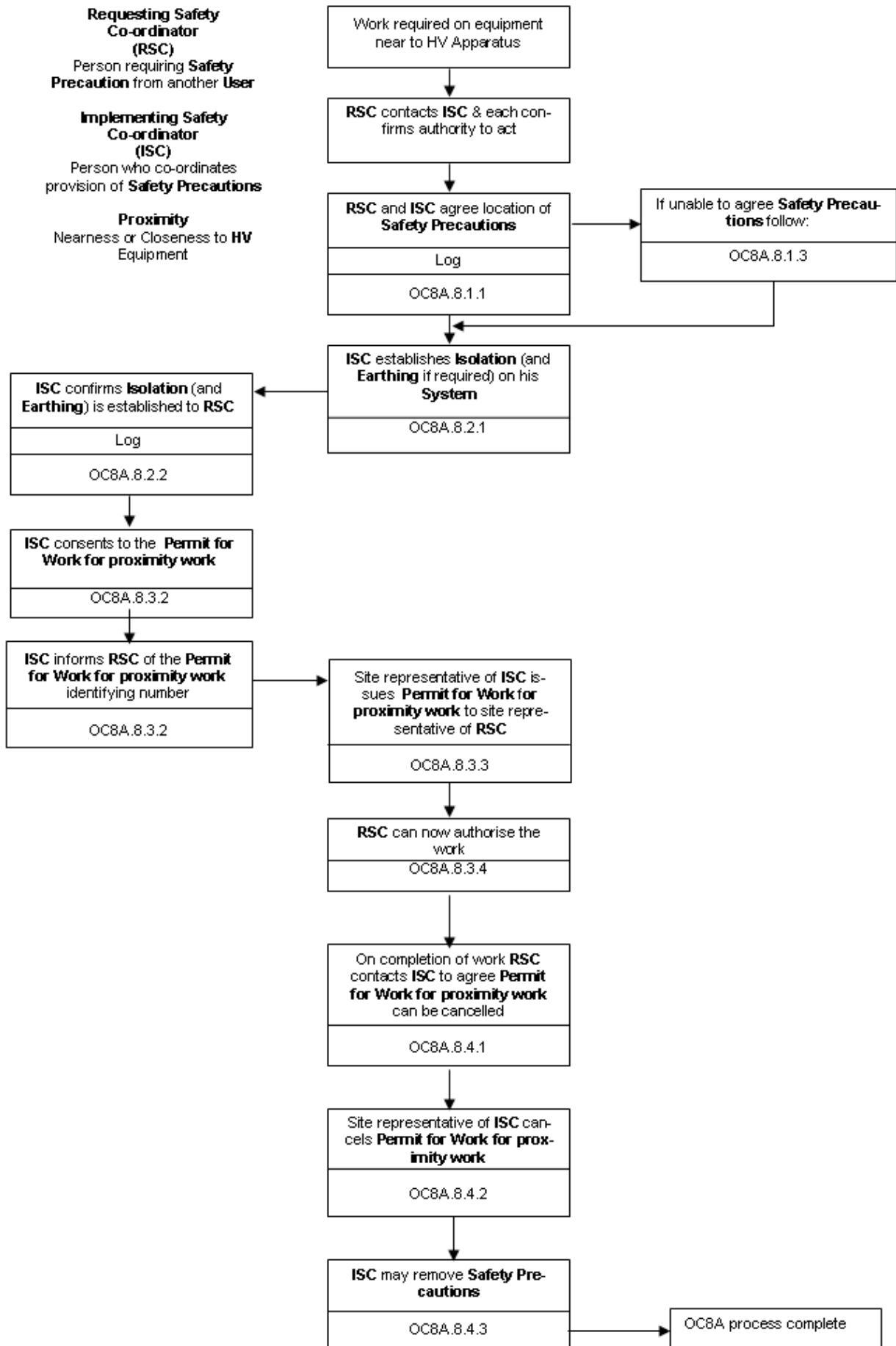

## APPENDIX D - NATIONAL GRID SAFETY CIRCULAR

|   |                       |
|---|-----------------------|
| <h1>National Grid Safety Circular<br/>(NGSC)</h1> | NGSC Number:<br>..... |
| RISSP prefixes - Issue x                          | Date:<br>Issued By:   |
| <h1>Example</h1>                                  |                       |

Pursuant to the objectives of The Grid Code, Operating Code 8A1 - Safety Co-ordination, this circular will be used in relation to all cross boundary safety management issues with the **Relevant E&W Transmission Licensee** customers. Of particular note will be the agreed prefixes for the Record of Inter System Safety Precautions (RISSP) documents.



# APPENDIX E - FORM OF NGET PERMIT TO WORK

[Form of the Relevant E&W Transmission Licensee Permit for Work]

|     |  |
|-----|--|
| No. |  |
|     |  |

## PERMIT FOR WORK

|    |   |
|----|---|
| 1. | <b>Location</b> .....<br>Equipment Identification.....<br>.....<br>Work to be done<br>.....<br>.....  |
| 2. | <b>Precautions taken to achieve Safety from the System</b><br><b>Points of Isolation</b><br>.....<br>.....<br><b>Primary Earths</b><br>.....<br>.....<br>.....<br>.....<br>Actions taken to avoid <b>Danger</b> by draining, venting, purging and containment or dissipation of stored energy*<br>.....<br>.....<br>Further precautions to be taken during the course of the work to avoid <b>System</b> derived hazards*<br>.....<br>..... |
| 3. | Precautions that may be varied*<br>.....<br>.....<br>.....<br>.....   |
| 4. | Preparation<br><b>Control Person(s) (Safety)</b> giving Consent <input type="text"/> <b>Key Safe number*</b> <input type="text"/><br>State whether this <b>Permit for Work</b> must be personally retained yes <input type="checkbox"/> no <input type="checkbox"/><br>Signed <input type="text"/> Time <input type="text"/> Date <input type="text"/><br><b>Senior Authorised Person</b>   |

|    |  |                      |   |                      |   |
|----|--|----------------------|---|----------------------|---|
| 5. | Issue & Receipt  |                      |   |                      |   |
|    | <b>Key Safe Number*</b>                                  | <input type="text"/> | <b>Safety Keys (No. off)*</b>                         | <input type="text"/> |   |
|    | <b>Earthing Schedule Number*</b>                         | <input type="text"/> | Portable <b>Drain earths (No. off)*</b>               | <input type="text"/> |   |
|    | Recommendations for <b>General Safety Report Number*</b> | <input type="text"/> | <b>Approved (ROMP)#/Card Safe#/ Procedure Number*</b> | <input type="text"/> |   |
|    | <b>Circuit Identification – Colours/ Symbols*</b>        | <input type="text"/> | Flags (No. off)*                                      | <input type="text"/> | Wristlets (No. off)* <input type="text"/> |
|    | Issued (Signed)  | <input type="text"/> |   |                      |   |
|    | <b>Senior Authorised Person</b>                          |                      |   |                      |   |
|    | Received (Signed)  | <input type="text"/> | Time  | <input type="text"/> | Date <input type="text"/>                 |
|    | <b>Competent Person</b>                                  |                      |   |                      |   |
|    | Name (Block letters)                                     | <input type="text"/> | Company   | <input type="text"/> |   |

# delete as appropriate \*write N/A if not applicable

February 1995

< END OF OPERATING CODE NO. 8 APPENDIX 1 >

# OPERATING CODE NO. 8 APPENDIX 2 (OC8B)

## SAFETY CO-ORDINATION IN RESPECT OF THE SCOTTISH TRANSMISSION SYSTEMS OR THE SYSTEMS OF SCOTTISH USERS

### CONTENTS

(This contents page does not form part of the Grid Code)

| <u>Paragraph No/Title</u>  | <u>Page Number</u> |
|--|--------------------|
| OC8B.1 INTRODUCTION .....  | 2                  |
| OC8B.2 OBJECTIVE .....   | 4                  |
| OC8B.3 SCOPE .....   | 4                  |
| OC8B.4 PROCEDURE .....   | 4                  |
| OC8B.4.1 Approval Of Safety Rules .....  | 4                  |
| OC8B.4.2 Safety Co-ordinators .....  | 5                  |
| OC8B.4.3 RISSP.....  | 5                  |
| OC8B.5 SAFETY PRECAUTIONS ON HV APPARATUS.....   | 7                  |
| OC8B.5.1 Agreement Of Safety Precautions.....  | 7                  |
| OC8B.5.2 Implementation Of Isolation .....   | 7                  |
| OC8B.5.3 Implementation of Earthing .....  | 8                  |
| OC8B.5.4 RISSP Issue Procedure .....   | 9                  |
| OC8B.5.5 RISSP Cancellation Procedure .....  | 9                  |
| OC8B.5.6 RISSP Change Control .....  | 10                 |
| OC8B.6 TESTING .....   | 10                 |
| OC8B.7 EMERGENCY SITUATIONS .....  | 11                 |
| OC8B.8 SAFETY PRECAUTIONS RELATING TO WORKING ON EQUIPMENT NEAR TO THE HV<br>SYSTEM..... | 11                 |
| OC8B.8.1 Agreement Of Safety Precautions.....  | 11                 |
| OC8B.8.2 Implementation Of Isolation And Earthing.....                                   | 12                 |
| OC8B.8.3 Permit For Work For Proximity Work Issue Procedure .....                        | 12                 |
| OC8B.8.4 Permit For Work For Proximity Work.....   | 13                 |
| OC8B.9 LOSS OF INTEGRITY OF SAFETY PRECAUTIONS .....                                     | 13                 |
| OC8B.10 SAFETY LOG .....   | 13                 |
| APPENDIX A - RISSP-R .....   | 14                 |
| APPENDIX B - RISSP-I.....  | 16                 |
| APPENDIX C- FLOWCHARTS .....   | 18                 |
| APPENDIX C1 - RISSP ISSUE PROCESS .....  | 18                 |
| APPENDIX C2 - TESTING PROCESS.....   | 19                 |
| APPENDIX C3 - RISSP CANCELLATION PROCESS .....   | 20                 |
| APPENDIX C4 - PROCESS FOR WORKING NEAR TO SYSTEM EQUIPMENT.....                          | 21                 |

APPENDIX D - NOT USED .....22  
APPENDIX E - FORM OF PERMIT TO WORK .....23

OC8B.1 INTRODUCTION

OC8B.1.1 **OC8B** specifies the standard procedures to be used by **NGET**, the **Relevant Scottish Transmission Licensees** and **Scottish Users** for the co-ordination, establishment and maintenance of necessary **Safety Precautions** when work is to be carried out on or near the **Scottish Transmission System** or the **System** of a **Scottish User** and when there is a need for **Safety Precautions** on **HV Apparatus** on the other's **System** for this work to be carried out safely. **OC8B** applies to **Relevant Scottish Transmission Licensees** and **Scottish Users**. Where work is to be carried out on or near equipment on an **E&W Transmission System** or the **Systems** of **E&W Users**, but such work requires **Safety Precautions** to be established on a **Scottish Transmission System** or the **Systems** of **Scottish Users**, **OC8B** should be followed by the **Relevant Scottish Transmission Licensee** and **Scottish Users** to establish the required **Safety Precautions**.

**OC8A** specifies the procedures to be used by the **Relevant E&W Transmission Licensee** and **E&W Users**.

**NGET** shall procure that **Relevant Scottish Transmission Licensees** shall comply with **OC8B** where and to the extent that such section applies to them.

In this **OC8B** the term “work” includes testing, other than **System Tests** which are covered by **OC12**.

OC8B.1.2 **OC8B** also covers the co-ordination, establishment and maintenance of necessary safety precautions on the **Implementing Safety Co-ordinator’s System** when work is to be carried out at a **Scottish User’s Site** or a **Transmission Site** (as the case may be) on equipment of the **Scottish User** or the **Relevant Scottish Transmission Licensee** as the case may be where the work or equipment is near to **HV Apparatus** on the **Implementing Safety Co-ordinator’s System**. In the case of **OTSUA**, a **Scottish User’s Site** or **Transmission Site** shall, for the purposes of this **OC8B**, include a site at which there is a **Transmission Interface Point** until the **OTSUA Transfer Time** and the provisions of this **OC8B** and references to **OTSUA** shall be construed and applied accordingly until the **OTSUA Transfer Time** at which time arrangements in respect of the **Transmission Interface Site** will have been put in place between the **Relevant Scottish Transmission Licensee** and the **Offshore Transmission Licensee**.

OC8B.1.3 **OC8B** does not apply to the situation where **Safety Precautions** need to be agreed solely between **Scottish Users**. **OC8B** does not apply to the situation where **Safety Precautions** need to be agreed solely between **Transmission Licensees**.

OC8B.1.4 **OC8B** does not seek to impose a particular set of **Safety Rules** on **Relevant Scottish Transmission Licensees** and **Scottish Users**. The **Safety Rules** to be adopted and used by the **Relevant Scottish Transmission Licensee** and each **Scottish User** shall be those chosen by each.

OC8B.1.5 **Site Responsibility Schedules** document the control responsibility for each item of **Plant** and **Apparatus** for each site.

OC8B.1.6 (a) The **Relevant Scottish Transmission Licensee** may agree alternative site-specific operational procedures with **Scottish Users** for the co-ordination, establishment and maintenance of **Safety Precautions** instead of the **Record of Inter-System Safety Precautions (“RISSP”)** procedure detailed in this **OC8B**. Such operational procedures shall satisfy the requirements of paragraphs OC8B.1.7, OC8B.2.1, OC8B.4.1, OC8B.4.2, OC8B.9, OC8B.10. These alternative site-specific operational procedures for the co-ordination, establishment and maintenance of **Safety Precautions** will be referenced in the relevant **Site Responsibility Schedule**.

(b) The **Relevant Scottish Transmission Licensee** may agree with **Scottish Users** site-specific procedures for the application of **Safety Precautions** across the interface between **Relevant Scottish Transmission Licensee** and **Scottish User** in addition to and consistent with either the **RISSP** procedure or the alternative site-specific operational procedures described in OC8B.1.6 (a). These site-specific procedures will be referenced in the relevant **Site Responsibility Schedule**.

- (c) The **Relevant Scottish Transmission Licensee** and the **Scottish User** shall comply with the procedures agreed pursuant to OC8B.1.6 (a) and OC8B.1.6 (b).

OC8B.1.7 Defined Terms

OC8B.1.7.1 **Scottish Users** should bear in mind that in **OC8** only, in order that **OC8** reads more easily with the terminology used in certain **Safety Rules**, the term "**HV Apparatus**" is defined more restrictively and is used accordingly in **OC8B**. **Scottish Users** should, therefore, exercise caution in relation to this term when reading and using **OC8B**.

OC8B.1.7.2 In **OC8** only the following terms shall have the following meanings:

- (1) "**HV Apparatus**" means **High Voltage** electrical circuits forming part of a **System**, on which **Safety From The System** may be required or on which **Safety Precautions** may be applied to allow work to be carried out on a **System**.
- (2) "**Isolation**" means the disconnection of **Apparatus** from the remainder of the **System** in which that **Apparatus** is situated by either of the following:
  - (a) an **Isolating Device** maintained in an isolating position. The isolating position must either be:
    - (i) maintained by immobilising and **Locking** the **Isolating Device** in the isolating position and affixing a **Caution Notice** to it. Where the **Isolating Device** is **Locked** with a **Safety Key**, the **Safety Key** must be secured in a **Key Safe** and the **Key Safe Key** must be given to the authorised site representative of the **Requesting Safety Co-ordinator** where reasonably practicable and is to be retained in safe custody. Where not reasonably practicable the **Key Safe Key** must be retained by the authorised site representative of the **Implementing Safety Co-ordinator** in safe custody; or
    - (ii) maintained and/or secured by such other method which must be in accordance with the **Safety Rules** of the **Relevant Scottish Transmission Licensee** or that **Scottish User**, as the case may be; or
  - (b) an adequate physical separation which must be in accordance with, and maintained by, the method set out in the **Safety Rules** of the **Relevant Scottish Transmission Licensee** or that **Scottish User**, as the case may be, and, if it is a part of that method, a **Caution Notice** must be placed at the point of separation; or
  - (c) in the case where the relevant **HV Apparatus** of the **Implementing Safety Co-ordinator** is being either constructed or modified, an adequate physical separation as a result of a **No System Connection**.
- (3) "**No System Connection**" means an adequate physical separation (which must be in accordance with, and maintained by, the method set out in the **Safety Rules** of the **Implementing Safety Co-ordinator**) of the **Implementing Safety Co-ordinator's HV Apparatus** from the rest of the **Implementing Safety Co-ordinator's System** where such **HV Apparatus** has no installed means of being connected to, and will not for the duration of the **Safety Precaution** be connected to, a source of electrical energy or to any other part of the **Implementing Safety Co-ordinator's System**.
- (4) "**Earthing**" means a way of providing a connection between conductors and earth by an **Earthing Device** which is either:
  - (i) immobilised and **Locked** in the earthing position. Where the **Earthing Device** is **Locked** with a **Safety Key**, the **Safety Key** must be secured in a **Key Safe** and the **Key Safe Key** must be given to the authorised site representative of the **Requesting Safety Co-ordinator** where reasonably practicable and is to be retained in safe custody. Where not reasonably practicable the **Key Safe Key** must be retained by the authorised site representative of the **Implementing Safety Co-ordinator** in safe custody; or
  - (ii) maintained and/or secured in position by such other method which must be in accordance with the **Safety Rules** of the **Relevant Scottish Transmission**

Licensee or that **Scottish User** as the case may be.

OC8B.1.7.3 For the purpose of the co-ordination of safety relating to **HV Apparatus** the term “**Safety Precautions**” means **Isolation** and/or **Earthing**.

## OC8B.2 OBJECTIVE

OC8B.2.1 The objective of **OC8B** is to achieve:-

- (i) **Safety From The System** when work on or near a **System** necessitates the provision of **Safety Precautions** on another **System** on **HV Apparatus** up to a **Connection Point** (or, in the case of **OTSUA**, **Transmission Interface Point**); and
- (ii) **Safety From The System** when work is to be carried out at a **Scottish User’s Site** or a **Transmission Site** (as the case may be) on equipment of the **Scottish User** or the **Relevant Scottish Transmission Licensee** (as the case may be) where the work or equipment is near to **HV Apparatus** on the **Implementing Safety Co-ordinator’s System**.

OC8B.2.2 A flow chart, set out in **OC8B** Appendix C, illustrates the process utilised in **OC8B** to achieve the objective set out in OC8B.2.1. In the case of a conflict between the flow chart and the provisions of the written text of **OC8B**, the written text will prevail.

## OC8B.3 SCOPE

OC8B.3.1 **OC8B** applies to **NGET**, **Relevant Scottish Transmission Licensees** and to **Scottish Users**, which in **OC8** means:-

- (a) **Generators** (including where undertaking **OTSDUW**);
- (b) **Network Operators**; and
- (c) **Non-Embedded Customers**.

The procedures for the establishment of safety co-ordination by **NGET** in relation to **External Interconnections** are set out in **Interconnection Agreements** with relevant persons for the **External Interconnections**.

## OC8B.4 PROCEDURE

### OC8B.4.1 Approval Of Safety Rules

- OC8B.4.1.1 (a) In accordance with the timing requirements of its **Bilateral Agreement**, each **Scottish User** will supply to the **Relevant Scottish Transmission Licensee** a copy of its **Safety Rules** relating to its side of the **Connection Point** at each **Connection Site** or in the case of **OTSUA** a copy of its **Local Safety Instructions** relating to its side of the **Transmission Interface Point** at each **Transmission Interface Site**.
- (b) In accordance with the timing requirements of each **Bilateral Agreement** the **Relevant Scottish Transmission Licensee** will supply to each **Scottish User** a copy of its **Safety Rules** relating to the **Transmission** side of the **Connection Point** at each **Connection Site** or in the case of **OTSUA** a copy of its **Local Safety Instructions** relating to the **Transmission** side of the **Transmission Interface Point** at each **Transmission Interface Site**.
- (c) Prior to connection the **Relevant Scottish Transmission Licensee** and the **Scottish User** must have approved each other’s relevant **Safety Rules** in relation to **Isolation** and **Earthing**.

- OC8B.4.1.2 Either party may require that the **Isolation** and/or **Earthing** provisions in the other party's **Safety Rules** affecting the **Connection Site** (or, in the case of OTSUA, Transmission Interface Site) should be made more stringent in order that approval of the other party's **Safety Rules** can be given. Provided these requirements are not unreasonable, the other party will make such changes as soon as reasonably practicable. These changes may need to cover the application of **Isolation** and/or **Earthing** at a place remote from the **Connection Site** (or, in the case of OTSUA, Transmission Interface Site), depending upon the **System** layout. Approval may not be withheld because the party required to approve reasonably believes the provisions relating to **Isolation** and/or **Earthing** are too stringent.
- OC8B.4.1.3 If, following approval, a party wishes to change the provisions in its **Safety Rules** relating to **Isolation** and/or **Earthing**, it must inform the other party. If the change is to make the provisions more stringent, then the other party merely has to note the changes. If the change is to make the provisions less stringent, then the other party needs to approve the new provisions and the procedures referred to in OC8B.4.1.2 apply.
- OC8B.4.2 Safety Co-ordinators
- OC8B.4.2.1 For each **Connection Point** (or, in the case of OTSUA, Transmission Interface Point), the **Relevant Scottish Transmission Licensee** and each **Scottish User** will have nominated to be available, to a timescale agreed in the **Bilateral Agreement**, a person or persons ("**Safety Co-ordinator(s)**") to be responsible for the co-ordination of **Safety Precautions** when work is to be carried out on a **System** which necessitates the provision of **Safety Precautions** on **HV Apparatus** pursuant to **OC8B**. A **Safety Co-ordinator** may be responsible for the co-ordination of safety on **HV Apparatus** at more than one **Connection Point** (or, in the case of OTSUA, Transmission Interface Point).
- OC8B.4.2.2 Each **Safety Co-ordinator** shall be authorised by the **Relevant Scottish Transmission Licensee** or a **Scottish User**, as the case may be, as competent to carry out the functions set out in **OC8B** to achieve **Safety From The System**. Confirmation from the **Relevant Scottish Transmission Licensee** or a **Scottish User**, as the case may be, that its **Safety Co-ordinator(s)** as a group are so authorised is dealt with, for **Scottish Users**, in CC.5.2 and for **Relevant Scottish Transmission Licensees** in the **STC**. Only persons with such authorisation will carry out the provisions of **OC8B**. Each **User** shall, prior to being connected to the **National Electricity Transmission System**, give notice in writing to the **Relevant Scottish Transmission Licensee** of its **Safety Co-ordinator(s)** and will update the written notice yearly and whenever there is a change to the identity of its **Safety Co-ordinators** or to the **Connection Points** (or, in the case of OTSUA, Transmission Interface Points). The **Relevant Scottish Transmission Licensee** will, at the time of a **Scottish User** being connected to the **National Electricity Transmission System** give notice in writing to that **Scottish User** of the identity of its **Safety Co-ordinator(s)** and will update the written notice whenever there is a change to the **Connection Points** (or, in the case of OTSUA, Transmission Interface Points) or **Safety Co-ordinators**.
- OC8B.4.2.3 Contact between **Safety Co-ordinators** will be made via normal operational channels, and accordingly separate telephone numbers for **Safety Co-ordinators** need not be provided.
- OC8B.4.2.4 If work is to be carried out on a **System**, or on equipment of the **Relevant Scottish Transmission Licensee** or a **Scottish User** near to a **System**, as provided in this **OC8B**, which necessitates the provision of **Safety Precautions** on **HV Apparatus** in accordance with the provisions of **OC8B**, the **Requesting Safety Co-ordinator** who requires the **Safety Precautions** to be provided shall contact the relevant **Implementing Safety Co-ordinator** to co-ordinate the establishment of the **Safety Precautions**.
- OC8B.4.3 RISSP
- OC8B.4.3.1 **OC8B** sets out the procedures for utilising the **RISSP**, which will be used except where dealing with equipment in proximity to the other's **System** as provided in **OC8B.8**. Sections **OC8B.4** to **OC8B.7** inclusive should be read accordingly.



- OC8B.4.3.2 The **Relevant Transmission Licensee** will use the format of the **RISSP** forms set out in Appendix A and Appendix B to **OC8B**, or any other format which may be agreed between the **Relevant Scottish Transmission Licensee** and each **User**. That set out in **OC8B** Appendix A and designated as "RISSP-R", shall be used when the **Relevant Scottish Transmission Licensee** is the **Requesting Safety Co-ordinator**, and that in **OC8B** Appendix B and designated as "RISSP-I", shall be used when the **Relevant Transmission Licensee** is the **Implementing Safety Co-ordinator**. Proformas of RISSP-R and RISSP-I will be provided for use by **Relevant Scottish Transmission Licensees** staff.
- OC8B.4.3.3 **Scottish Users** may either adopt the format referred to in OC8B.4.3.2 or any other format which may be agreed between the **Relevant Scottish Transmission Licensee** and the **Scottish User** from time to time.
- OC8B.4.3.4 All references to RISSP-R and RISSP-I shall be taken as referring to the corresponding parts of the alternative forms or other tangible written or electronic records used by each **Scottish User** or **Relevant Scottish Transmission Licensee**.
- OC8B.4.3.5 RISSP-R will have an identifying number written or printed on it, comprising a prefix which identifies the location at which it is issued, and a unique (for each **Scottish User** or **Relevant Scottish Transmission Licensee**, as the case may be) serial number which both together uses up to eight characters (including letters and numbers) and the suffix "R".
- OC8B.4.3.6
- (a) In accordance with the timing requirements set out in the **Bilateral Agreement** each **Scottish User** shall apply in writing to **Relevant Scottish Transmission Licensee** for **Relevant Scottish Transmission Licensee's** approval of its proposed prefix.
  - (b) **Relevant Scottish Transmission Licensee** shall consider the proposed prefix to see if it is the same as (or confusingly similar to) a prefix used by **Relevant Scottish Transmission Licensee** or another **User** and shall, as soon as possible (and in any event within ten days), respond in writing to the **Scottish User** with its approval or disapproval.
  - (c) If **Relevant Scottish Transmission Licensee** disapproves, it shall explain in its response why it has disapproved and will suggest an alternative prefix.
  - (d) If **Relevant Scottish Transmission Licensee** has disapproved, then the **Scottish User** shall either notify **Relevant Scottish Transmission Licensee** in writing of its acceptance of the suggested alternative prefix or it shall apply in writing to **Relevant Scottish Transmission Licensee** with revised proposals and the above procedure shall apply to that application.

- OC8B.5 SAFETY PRECAUTIONS ON HV APPARATUS
- OC8B.5.1 Agreement Of Safety Precautions
- OC8B.5.1.1 The **Requesting Safety Co-ordinator** who requires **Safety Precautions** on another **System(s)** will contact the relevant **Implementing Safety Co-ordinator(s)** to agree the **Location** of the **Safety Precautions** to be established. This agreement will be recorded in the respective **Safety Logs**.
- OC8B.5.1.2 It is the responsibility of the **Implementing Safety Co-ordinator** to ensure that adequate **Safety Precautions** are established and maintained, on his and/or another **System** connected to his **System**, to enable **Safety From The System** to be achieved on the **HV Apparatus**, specified by the **Requesting Safety Co-ordinator** which is to be identified in Part 1.1 of the **RISSP**. Reference to another **System** in this OC8B.5.1.2 shall not include the **Requesting Safety Co-ordinator's System** which is dealt with in OC8B.5.1.3.
- OC8B.5.1.3 When the **Implementing Safety Co-ordinator** is of the reasonable opinion that it is necessary for **Safety Precautions** on the **System** of the **Requesting Safety Co-ordinator**, other than on the **HV Apparatus** specified by the **Requesting Safety Co-ordinator**, which is to be identified in Part 1.1 of the **RISSP**, he shall contact the **Requesting Safety Co-ordinator** and the details shall be recorded in part 1.1 of the **RISSP** forms. In these circumstances it is the responsibility of the **Requesting Safety Co-ordinator** to establish and maintain such **Safety Precautions**.
- OC8B.5.1.4 The location of the **Safety Precautions** should be indicated on each **Scottish User's** operational diagram and labelled as per the local instructions of each **Scottish User**.
- OC8B.5.1.5 In The Event Of Disagreement
- In any case where the **Requesting Safety Co-ordinator** and the **Implementing Safety Co-ordinator** are unable to agree the **Location** of the **Isolation** and (if requested) **Earthing**, both shall be at the closest available points on the infeeds to the **HV Apparatus** on which **Safety From The System** is to be achieved as indicated on the **Operation Diagram**.
- OC8B.5.2 Implementation Of Isolation
- OC8B.5.2.1 Following the agreement of the **Safety Precautions** in accordance with OC8B.5.1 the **Implementing Safety Co-ordinator** shall then establish the agreed **Isolation**.
- OC8B.5.2.2 The **Implementing Safety Co-ordinator** shall confirm to the **Requesting Safety Co-ordinator** that the agreed **Isolation** has been established, and identify the **Requesting Safety Co-ordinator's HV Apparatus** up to the **Connection Point** (or, in the case of OTSUA, Transmission Interface Point), for which the **Isolation** has been provided. The confirmation shall specify:
- (a) for each **Location**, the identity (by means of **HV Apparatus** name, nomenclature and numbering or position, as applicable) of each point of **Isolation**;
  - (b) whether **Isolation** has been achieved by an **Isolating Device** in the isolating position, by an adequate physical separation or as a result of a **No System Connection**;
  - (c) where an **Isolating Device** has been used whether the isolating position is either :
    - (i) maintained by immobilising and **Locking** the **Isolating Device** in the isolating position and affixing a **Caution Notice** to it. Where the **Isolating Device** has been **Locked** with a **Safety Key**, the confirmation shall specify that the **Safety Key** has been secured in a **Key Safe** and the **Key Safe Key** has been given to the authorised site representative of the **Requesting Safety Co-ordinator** where reasonably practicable and is to be retained in safe custody. Where not reasonably practicable (including where **Earthing** has been requested in OC8B.5.1), the confirmation shall specify that the **Key Safe Key** will be retained by the authorised site representative of the **Implementing Safety Co-ordinator** in safe custody; or

- (ii) maintained and/or secured by such other method which must be in accordance with the **Safety Rules** of the **Relevant Scottish Transmission Licensee** or that **Scottish User**, as the case may be; and
- (d) where an adequate physical separation has been used that it will be in accordance with, and maintained by, the method set out in the **Safety Rules** of the **Relevant Scottish Transmission Licensee** or that **Scottish User**, as the case may be, and, if it is a part of that method, that a **Caution Notice** has been placed at the point of separation;
- (e) where a **No System Connection** has been used the physical position of the **No System Connection** shall be defined and shall not be varied for the duration of the **Safety Precaution** and the **Implementing Safety Co-ordinator's** relevant **HV Apparatus** will not, for the duration of the **Safety Precaution** be connected to a source of electrical energy or to any other part of the **Implementing Safety Co-ordinator's System**.

The confirmation of **Isolation** shall be recorded in the respective **Safety Logs**.

OC8B.5.2.3 Following the confirmation of **Isolation** being established by the **Implementing Safety Co-ordinator** and the necessary establishment of relevant **Isolation** on the **Requesting Safety Co-ordinators System**, the **Requesting Safety Co-ordinator** will then request the implementation of **Earthing** by the **Implementing Safety Co-ordinator**, if agreed in section OC8B.5.1. If the implementation of **Earthing** has been agreed, then the authorised site representative of the **Implementing Safety Co-ordinator** shall retain any **Key Safe Key** in safe custody until any **Safety Key** used for **Earthing** has been secured in the **Key Safe**.

#### OC8B.5.3 Implementation Of Earthing

OC8B.5.3.1 The **Implementing Safety Co-ordinator** shall then establish the agreed **Earthing**.

OC8B.5.3.2 The **Implementing Safety Co-ordinator** shall confirm to the **Requesting Safety Co-ordinator** that the agreed **Earthing** has been established, and identify the **Requesting Safety Co-ordinator's HV Apparatus** up to the **Connection Point** (or, in the case of OTSUA, Transmission Interface Point), for which the **Earthing** has been provided. The confirmation shall specify:

- (a) for each **Location**, the identity (by means of **HV Apparatus** name, nomenclature and numbering or position, as is applicable) of each point of **Earthing**; and
- (b) in respect of the **Earthing Device** used, whether it is:
  - (i) immobilised and **Locked** in the earthing position. Where the **Earthing Device** has been **Locked** with a **Safety Key**, that the **Safety Key** has been secured in a **Key Safe** and the **Key Safe Key** has been given to the authorised site representative of the **Requesting Safety Co-ordinator** where reasonably practicable and is to be retained in safe custody. Where not reasonably practicable, that the **Key Safe Key** will be retained by the authorised site representative of the **Implementing Safety Co-ordinator** in safe custody; or
  - (ii) maintained and/or secured in position by such other method which is in accordance with the **Safety Rules** of the **Relevant Scottish Transmission Licensee** or that **Scottish User**, as the case may be.

The confirmation of **Earthing** shall be recorded in the respective **Safety Logs**.

OC8B.5.3.3 The **Implementing Safety Co-ordinator** shall ensure that the established **Safety Precautions** are maintained until requested to be removed by the relevant **Requesting Safety Co-ordinator**.

OC8B.5.3.4 Certain designs of gas insulated switchgear three position isolator and earth switches specifically provide a combined **Isolation** and **Earthing** function within a single mechanism contained within a single integral unit. Where **Safety Precautions** are required across control boundaries and subject to the requirements of OC8B.5.1, it is permissible to earth before **Points of Isolation** have been established provided that all interconnected circuits are fully disconnected from live **HV Apparatus**.

- OC8B.5.4 RISSP Issue Procedure
- OC8B.5.4.1 Where **Safety Precautions** on another **System(s)** are being provided to enable work on the **Requesting Safety Co-ordinator's System**, before any work commences they must be recorded by a **RISSP** being issued. The **RISSP** is applicable to **HV Apparatus** up to the **Connection Point** (or, in the case of OTSUA, Transmission Interface Point) identified in section 1.1 of the RISSP-R and RISSP-I forms.
- OC8B.5.4.2 Where **Safety Precautions** are being provided to enable work to be carried out on both sides of the **Connection Point** (or, in the case of OTSUA, Transmission Interface Point) a **RISSP** will need to be issued for each side of the **Connection Point** (or, in the case of OTSUA, Transmission Interface Point) with **Relevant Scottish Transmission Licensee** and the respective **User** each enacting the role of **Requesting Safety Co-ordinator**. This will result in a RISSP-R and a RISSP-I form being completed by each of the **Relevant Scottish Transmission Licensee** and the **Scottish User**, with each **Requesting Safety Co-ordinator** issuing a separate **RISSP** number.
- OC8B.5.4.3 Once the **Safety Precautions** have been established (in accordance with OC8B.5.2 and OC8B.5.3), the **Implementing Safety Co-ordinator** shall complete parts 1.1 and 1.2 of a RISSP-I form recording the details specified in OC8B.5.1.3, OC8B.5.2.2 and OC8B.5.3.2. Where **Earthing** has not been requested, Part 1.2(b) will be completed with the words "not applicable" or "N/A". He shall then contact the **Requesting Safety Co-ordinator** to pass on these details.
- OC8B.5.4.4 The **Requesting Safety Co-ordinator** shall complete Parts 1.1 and 1.2 of the RISSP-R, making a precise copy of the details received. On completion, the **Requesting Safety Co-ordinator** shall read the entries made back to the sender and check that an accurate copy has been made.
- OC8B.5.4.5 The **Requesting Safety Co-ordinator** shall then issue the number of the **RISSP**, taken from the RISSP-R, to the **Implementing Safety Co-ordinator** who will ensure that the number, including the prefix and suffix (where applicable), is accurately recorded in the designated space on the RISSP-I form.
- OC8B.5.4.6 The **Requesting Safety Co-ordinator** and the **Implementing Safety Co-ordinator** shall complete and sign Part 1.3 of the RISSP-R and RISSP-I respectively and then enter the time and date. When signed no alteration to the **RISSP** is permitted; the **RISSP** may only be cancelled.
- OC8B.5.4.7 The **Requesting Safety Co-ordinator** is then free to authorise work, but not testing, in accordance with the requirements of the relevant internal safety procedures which apply to the **Requesting Safety Co-ordinator's System**. This is likely to involve the issue of safety documents or other relevant internal authorisations. Where testing is to be carried out, the procedure set out below in OC8B.6 shall be implemented.
- OC8B.5.5 RISSP Cancellation Procedure
- OC8B.5.5.1 When the **Requesting Safety Co-ordinator** decides that **Safety Precautions** are no longer required, he will contact the relevant **Implementing Safety Co-ordinator** to effect cancellation of the associated **RISSP**.
- OC8B.5.5.2 The **Requesting Safety Co-ordinator** will inform the relevant **Implementing Safety Co-ordinator** of the **RISSP** identifying number, including the prefix and suffix (where applicable), and agree it is the **RISSP** to be cancelled.
- OC8B.5.5.3 The **Requesting Safety Co-ordinator** and the relevant **Implementing Safety Co-ordinator** shall then respectively complete Part 2.1 of their respective RISSP-R and RISSP-I forms and shall then exchange details. The details being exchanged shall include their respective names and time and date. On completion of the exchange of details the respective **RISSP** is cancelled. The removal of **Safety Precautions** is as set out in OC8B.5.5.4 and OC8B.5.5.5.

OC8B.5.5.4 Neither **Safety Co-ordinator** shall instruct the removal of any **Isolation** forming part of the **Safety Precautions** as part of the returning of the **HV Apparatus** to service until it is confirmed to each by each other that every earth on each side of the **Connection Point** (or, in the case of OTSUA, Transmission Interface Point), within the points of isolation identified on the **RISSP**, has been removed or disconnected by the provision of additional **Points of Isolation**.

OC8B.5.5.5 Subject to the provisions in OC8B.5.5.4, the **Implementing Safety Co-ordinator** is then free to arrange the removal of the **Safety Precautions**, the procedure to achieve that being entirely an internal matter for the party the **Implementing Safety Co-ordinator** is representing. Where a **Key Safe Key** has been given to the authorised site representative of the **Requesting Safety Co-ordinator**, the **Key Safe Key** must be returned to the authorised site representative of the **Implementing Safety Co-ordinator**. The only situation in which any **Safety Precautions** may be removed without first cancelling the **RISSP** in accordance with OC8B.5.5 or OC8B.5.6 is when **Earthing** is removed in the situation envisaged in OC8B.6.2(b).

#### OC8B.5.6 RISSP Change Control

Nothing in this **OC8B** prevents **Relevant Scottish Transmission Licensee** and **Scottish Users** agreeing to a simultaneous cancellation and issue of a new **RISSP**, if both agree. It should be noted, however, that the effect of that under the relevant **Safety Rules** is not a matter with which the **Grid Code** deals.

#### OC8B.6 TESTING

OC8B.6.1 The carrying out of the test may affect **Safety Precautions** on **RISSPs** or work being carried out which does not require a **RISSP**. Testing can, for example, include the application of an independent test voltage. Accordingly, where the **Requesting Safety Co-ordinator** wishes to authorise the carrying out of such a test to which the procedures in OC8B.6 apply he may not do so and the test will not take place unless and until the steps in (a)-(c) below have been followed and confirmation of completion has been recorded in the respective **Safety Logs**:

- (a) confirmation must be obtained from the **Implementing Safety Co-ordinator** that:
  - (i) no person is working on, or testing, or has been authorised to work on, or test, any part of its **System** or another **System(s)** (other than the **System** of the **Requesting Safety Co-ordinator**) within the points of **Isolation** identified on the **RISSP** form relating to the test which is proposed to be undertaken, and
  - (ii) no person will be so authorised until the proposed test has been completed (or cancelled) and the **Requesting Safety Co-ordinator** has notified the **Implementing Safety Co-ordinator** of its completion (or cancellation);
- (b) any other current **RISSPs** which relate to the parts of the **System** in which the testing is to take place must have been cancelled in accordance with procedures set out in OC8B.5.5;
- (c) the **Implementing Safety Co-ordinator** must agree with the **Requesting Safety Co-ordinator** to permit the testing on that part of the **System** between the points of **Isolation** identified in the **RISSP** associated with the test and the points of **Isolation** on the **Requesting Safety Co-ordinator's System**.

OC8B.6.2 (a) The **Requesting Safety Co-ordinator** will inform the **Implementing Safety Co-ordinator** as soon as the test has been completed or cancelled and the confirmation shall be recorded in the respective **Safety Logs**.

(b) When the test gives rise to the removal of **Earthing** which it is not intended to re-apply, the relevant **RISSP** associated with the test shall be cancelled at the completion or cancellation of the test in accordance with the procedure set out in either OC8B.5.5 or OC8B.5.6. Where the **Earthing** is re-applied following the completion or cancellation of the test, there is no requirement to cancel the relevant **RISSP** associated with the test pursuant to this OC8B.6.2.

OC8B.7 EMERGENCY SITUATIONS

OC8B.7.1 There may be circumstances where **Safety Precautions** need to be established in relation to an unintended electrical connection or situations where there is an unintended risk of electrical connection between the **National Electricity Transmission System** and a **Scottish User's System**, for example resulting from an incident where one line becomes attached or unacceptably close to another.

OC8B.7.2 In those circumstances, if both the **Relevant Scottish Transmission Licensee** the **Scottish User** agree, the relevant provisions of OC8B.5 will apply as if the electrical connections or potential connections were, solely for the purposes of this OC8B, a **Connection Point** (or, in the case of OTSUA, Transmission Interface Point).

OC8B.7.3 (a) The relevant **Safety Co-ordinator** shall be that for the electrically closest existing **Connection Point** (or, in the case of OTSUA, Transmission Interface Point) to that **Scottish User's System** or such other local **Connection Point** (or, in the case of OTSUA, Transmission Interface Point) as may be agreed between the **Relevant Scottish Transmission Licensee** and the **Scottish User**, with discussions taking place between the relevant local **Safety Co-ordinators**. The **Connection Point** (or, in the case of OTSUA, Transmission Interface Point) to be used shall be known in this OC8B.7.3 as the "relevant **Connection Point**" (or, in the case of OTSUA, relevant "Transmission Interface Point").

(b) The **Safety Rules** shall be those which apply to the relevant **Connection Point** (or, in the case of OTSUA, Transmission Interface Point).

(c) The prefix for the **RISSP** (where applicable) will be that which applies for the relevant **Connection Point** (or, in the case of OTSUA, Transmission Interface Point).

OC8B.8 SAFETY PRECAUTIONS RELATING TO WORKING ON EQUIPMENT NEAR TO THE HV SYSTEM

OC8B.8 applies to the situation where work is to be carried out at a **Scottish User's Site** or a **Transmission Site** (as the case may be) on equipment of the **Scottish User** or a **Relevant Scottish Transmission Licensee** as the case may be, where the work or equipment is near to **HV Apparatus** on the **Implementing Safety Co-ordinator's System**. It does not apply to other situations to which **OC8B** applies. In this part of **OC8B**, a **Permit for Work for proximity work** is to be used, rather than the usual **RISSP** procedure, given the nature and effect of the work, all as further provided in the OC8B.8.

OC8B.8.1 Agreement Of Safety Precautions

OC8B.8.1.1 The **Requesting Safety Co-ordinator** who requires **Safety Precautions** on another **System(s)** when work is to be carried out at a **Scottish User's Site** or a **Transmission Site** (as the case may be) on equipment of the **Scottish User** or a **Relevant Scottish Transmission Licensee**, as the case may be, where the work or equipment is near to **HV Apparatus** on the **Implementing Safety Co-ordinator's System** will contact the relevant **Implementing Safety Co-ordinator(s)** to agree the Location of the **Safety Precautions** to be established, having as part of this process informed the **Implementing Safety Co-ordinator** of the equipment and the work to be undertaken. The respective **Safety Co-ordinators** will ensure that they discuss the request with their authorised site representative and that the respective authorised site representatives discuss the request at the **Connection Site** (or, in the case of OTSUA, Transmission Interface Site). This agreement will be recorded in the respective **Safety Logs**.

- OC8B.8.1.2 It is the responsibility of the **Implementing Safety Co-ordinator**, working with his authorised site representative as appropriate, to ensure that adequate **Safety Precautions** are established and maintained, on his and/or another **System** connected to his **System**, to enable **Safety From The System** to be achieved for work to be carried out at a **Scottish User's Site** or a **Transmission Site** (as the case may be) on equipment and in relation to work which is to be identified in the relevant part of the **Permit for Work for proximity work** where the work or equipment is near to **HV Apparatus** of the **Implementing Safety Co-ordinator's System** specified by the **Requesting Safety Co-ordinator**. Reference to another **System** in this OC8B.8.1.2 shall not include the **Requesting Safety Co-ordinator's System**.
- OC8B.8.1.3 In The Event Of Disagreement
- In any case where the **Requesting Safety Co-ordinator** and the **Implementing Safety Co-ordinator** are unable to agree the **Location** of the **Isolation** and (if requested) **Earthing**, both shall be at the closest available points on the infeeds to the **HV Apparatus** near to which the work is to be carried out as indicated on the **Operation Diagram**.
- OC8B.8.2 Implementation Of Isolation And Earthing
- OC8B.8.2.1 Following the agreement of the **Safety Precautions** in accordance with OC8B.8.1 the **Implementing Safety Co-ordinator** shall then establish the agreed **Isolation** and (if required) **Earthing**.
- OC8B.8.2.2 The **Implementing Safety Co-ordinator** shall confirm to the **Requesting Safety Co-ordinator** that the agreed **Isolation** and (if required) **Earthing** has been established.
- OC8B.8.2.3 The **Implementing Safety Co-ordinator** shall ensure that the established **Safety Precautions** are maintained until requested to be removed by the relevant **Requesting Safety Co-ordinator**.
- OC8B.8.3 Permit For Work For Proximity Work Issue Procedure
- OC8B.8.3.1 Where **Safety Precautions** on another **System(s)** are being provided to enable work to be carried out at a **Scottish User's Site** or **Transmission Site** (as the case may be) on equipment where the work or equipment is in proximity to **HV Apparatus** of the **Implementing Safety Co-ordinator**, before any work commences they must be recorded by a **Permit for Work for proximity work** being issued. The **Permit for Work for proximity work** shall identify the **Implementing Safety Co-ordinator's HV Apparatus** in proximity to the required work
- OC8B.8.3.2 Once the **Safety Precautions** have been established (in accordance with OC8B.8.2), the **Implementing Safety Co-ordinator** shall agree to the issue of the **Permit for Work for proximity work** with the appropriately authorised site representative of the **Requesting Safety Co-ordinator's Site**. The **Implementing Safety Co-ordinator** will inform the **Requesting Safety Co-ordinator** of the **Permit for Work for proximity work** identifying number.
- OC8B.8.3.3 The appropriately authorised site representative of the **Implementing Safety Co-ordinator** shall then issue the **Permit for Work for proximity work** to the appropriately authorised site representative of the **Requesting Safety Co-ordinator**. The **Permit for Work for proximity work** will in the section dealing with the work to be carried out, be completed to identify that the work is near the **Implementing Safety Co-ordinator's HV Apparatus**. No further details of the **Requesting Safety Co-ordinator's** work will be recorded, as that is a matter for the **Requesting Safety Co-ordinator** in relation to his work.
- OC8B.8.3.4 The **Requesting Safety Co-ordinator** is then free to authorise work in accordance with the requirements of the relevant internal safety procedures which apply to the **Requesting Safety Co-ordinator's Site**. This is likely to involve the issue of safety documents or other relevant internal authorisations.

- OC8B.8.4 Permit For Work For Proximity Work Cancellation Procedure
- OC8B.8.4.1 When the **Requesting Safety Co-ordinator** decides that **Safety Precautions** are no longer required, he will contact the relevant **Implementing Safety Co-ordinator** to effect cancellation of the associated **Permit for Work for proximity work**.
- OC8B.8.4.2 The **Requesting Safety Co-ordinator** will inform the relevant **Implementing Safety Co-ordinator** of the **Permit for Work for proximity work** identifying number, and agree that the **Permit for Work for proximity work** can be cancelled. The cancellation is then effected by the appropriately authorised site representative of the **Requesting Safety Co-ordinator** returning the **Permit for Work for proximity work** to the appropriately authorised site representative of the **Implementing Safety Co-ordinator**.
- OC8B.8.4.3 The **Implementing Safety Co-ordinator** is then free to arrange the removal of the **Safety Precautions**, the procedure to achieve that being entirely an internal matter for the party the **Implementing Safety Co-ordinator** is representing.
- OC8B.9 LOSS OF INTEGRITY OF SAFETY PRECAUTIONS
- OC8B.9.1 In any instance when any **Safety Precautions** may be ineffective for any reason the relevant **Safety Co-ordinator** shall inform the other **Safety Co-ordinator(s)** without delay of that being the case and, if requested, of the reasons why.
- OC8B.10 SAFETY LOG
- OC8B.10.1 **Relevant Scottish Transmission Licensees** and **Scottish Users** shall maintain **Safety Logs** which shall be a chronological record of all messages relating to safety co-ordination under **OC8** sent and received by the **Safety Co-ordinator(s)**. The **Safety Logs** must be retained for a period of not less than six years.



# APPENDIX A - RISSP-R

## RECORD OF INTER-SYSTEM SAFETY PRECAUTIONS (RISSP-R) (Requesting Safety Co-ordinator's Record)

RISSP NUMBER \_\_\_\_\_

### Part 1

#### 1.1 CIRCUIT IDENTIFICATION

Safety Precautions have been established by the Implementing Safety Co-ordinator to achieve Safety From The System on the following HV Apparatus:

---

---

---

---

---

---

---

---

#### 1.2 SAFETY PRECAUTIONS ESTABLISHED

##### (a) ISOLATION

State the Locations(s) at which Isolation has been established on the Implementing Safety Co-ordinator's System. For each Location, identify each point of Isolation. For each point of Isolation state, the means by which the Isolation has been achieved, and whether, immobilised and Locked, Caution Notice affixed, other Safety Precautions applied, as appropriate.

---

---

---

---

---

---

---

---

(b) EARTHING

State the Locations(s) at which Earthing has been established on the Implementing Safety Co-ordinator's System. For each Location, identify each point of Earthing. For each point of Earthing state, the means by which the Earthing has been achieved, and whether, immobilised and Locked, other Safety Precautions applied, as appropriate.

---

---

---

---

---

---

---

---

1.3 ISSUE

I have received confirmation from \_\_\_\_\_ (name of Implementing Safety Co-ordinator) at \_\_\_\_\_ (Location) that the Safety Precautions identified in paragraph 1.2 have been established and that instructions will not be issued at his Location for their removal until this RISSP is cancelled.

Signed ..... (Requesting Safety Co-ordinator)

at ..... (time) on ..... (date)

PART 2

2.1 CANCELLATION

I have confirmed to \_\_\_\_\_ (name of the Implementing Safety Co-ordinator) at \_\_\_\_\_ (Location) that the Safety Precautions set out in paragraph 1.2 are no longer required and accordingly the RISSP is cancelled.

Signed ..... (Requesting Safety Co-ordinator)

at ..... (time) on ..... (date).....

# APPENDIX B - RISSP-I

## RECORD OF INTER-SYSTEM SAFETY PRECAUTIONS (RISSP-I) (Implementing Safety Co-ordinator's Record)

RISSP NUMBER \_\_\_\_\_

### PART 1

#### 1.1 CIRCUIT IDENTIFICATION

Safety Precautions have been established by the Implementing Safety Co-ordinator to achieve Safety From The System on the following HV Apparatus:

---

---

---

---

---

---

---

---

#### 1.2 SAFETY PRECAUTIONS ESTABLISHED

##### (a) ISOLATION

State the Location(s) at which isolation has been established on the Implementing Safety Co-ordinator's System. For each Location, identify each point of Isolation. For each point of Isolation state, the means by which the Isolation has been achieved, and whether, immobilised and Locked, Caution Notice affixed, other Safety Precautions applied, as appropriate.

---

---

---

---

---

---

---

---

(b) EARTHING

State the Location(s) at which Earthing has been established on the Implementing Safety Co-ordinator's System. For each Location, identify each point of Earthing. For each point of Earthing state, the means by which the Earthing has been achieved, and whether, immobilised and Locked, other Safety Precautions applied, as appropriate.

---

---

---

---

---

---

---

---

1.3 ISSUE

I confirmed to \_\_\_\_\_ (name of Requesting Safety Co-ordinator) at \_\_\_\_\_ (Location) that the Safety Precautions identified in paragraph 1.2 have been established and that instructions will not be issued at my Location for their removal until this RISSP is cancelled.

Signed ..... (Implementing Safety Co-ordinator)

at ..... (time) on ..... (date)

PART 2

2.1 CANCELLATION

I have received confirmation from \_\_\_\_\_ (name of the Requesting Safety Co-ordinator) at \_\_\_\_\_ (Location) that the Safety Precautions set out in paragraph 1.2 are no longer required and accordingly the RISSP is cancelled.

Signed ..... (Implementing Safety Co-ordinator)

at ..... (time) on ..... (date)

(Note: This form to be of a different colour from RISSP-R.)

# APPENDIX C - FLOWCHARTS

## APPENDIX C1 - RISSP ISSUE PROCESS

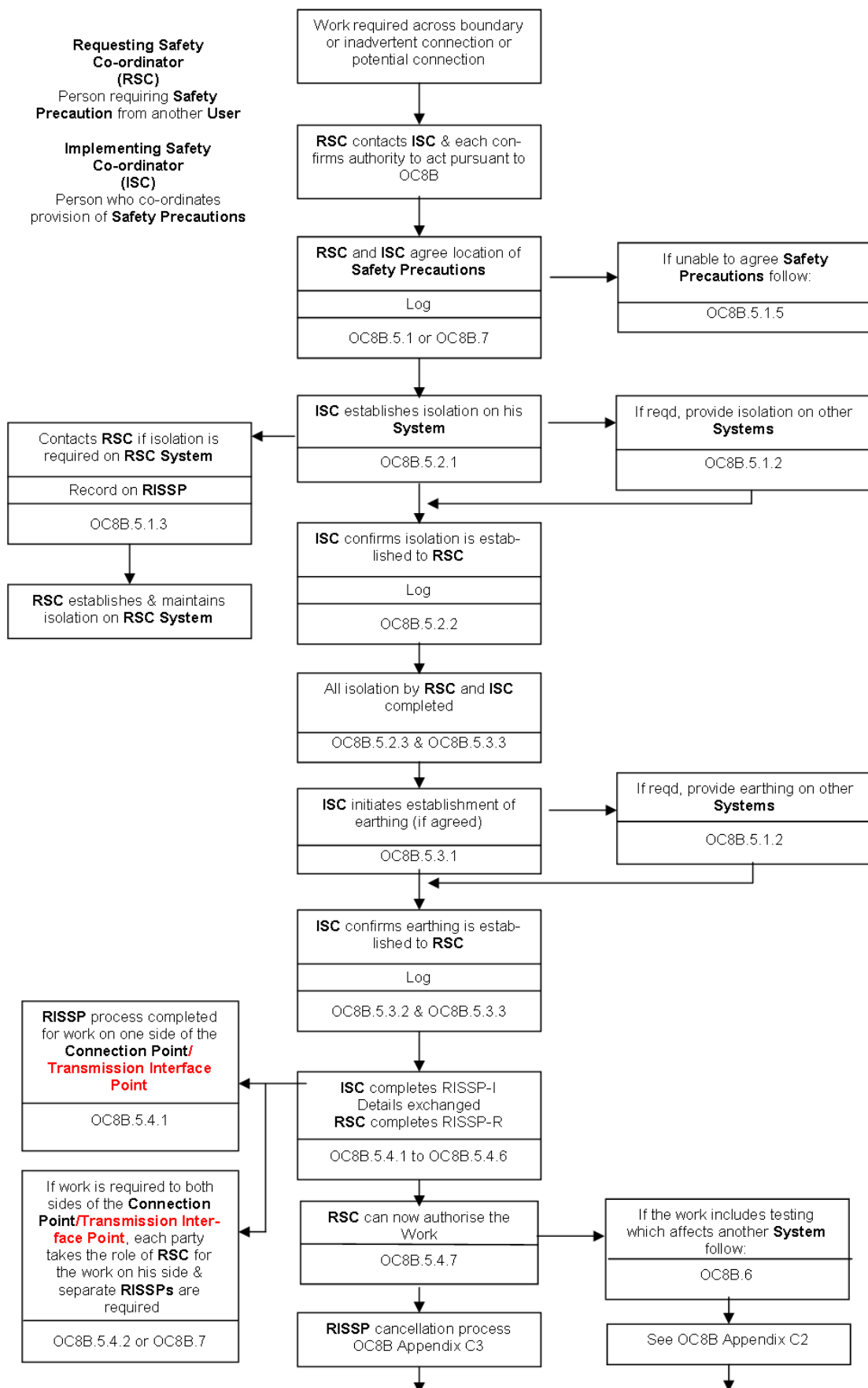

## APPENDIX C2 - TESTING PROCESS

**Where testing affects another Safety Co-ordinator's System**

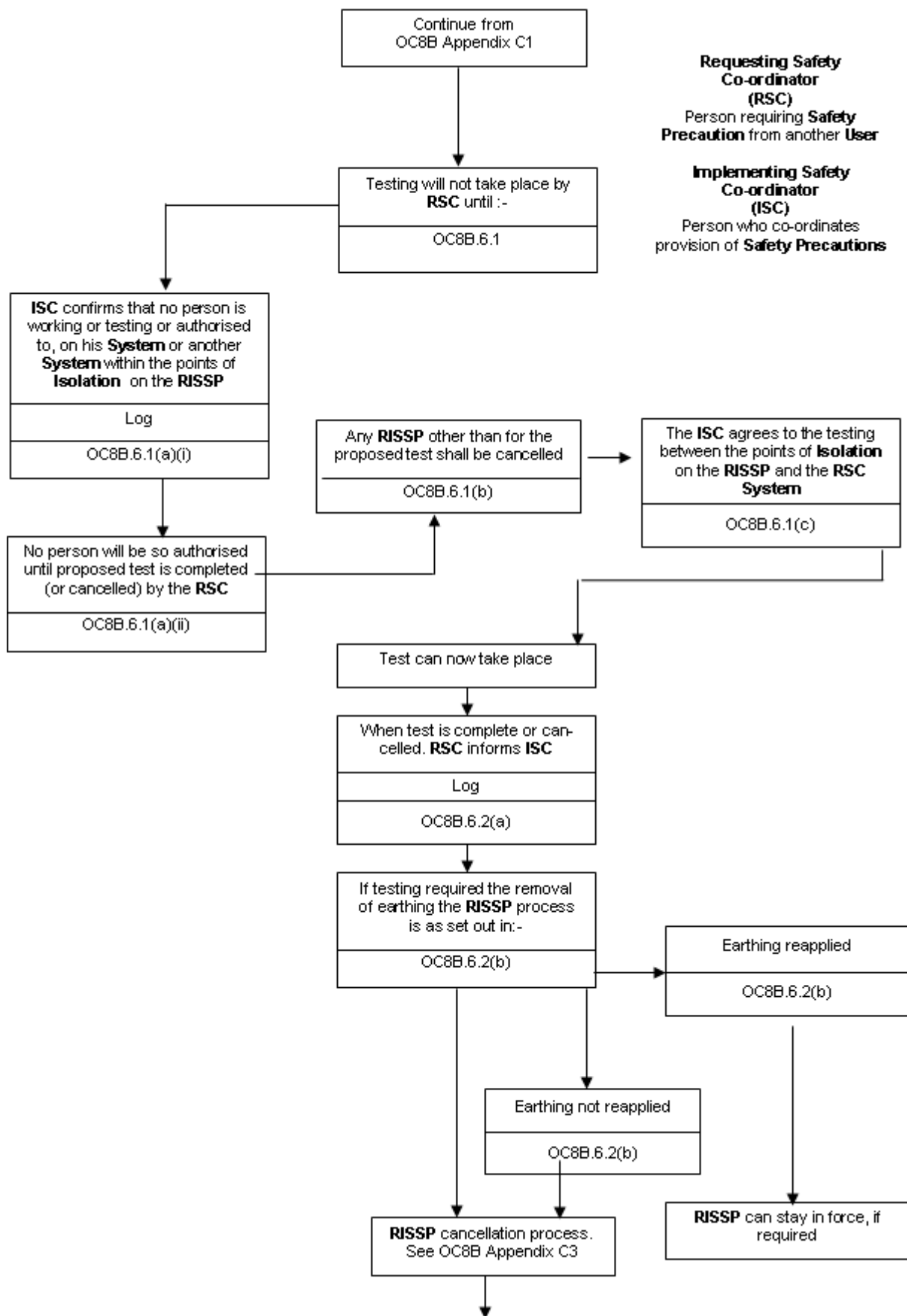

## APPENDIX C3 - RISSP CANCELLATION PROCESS

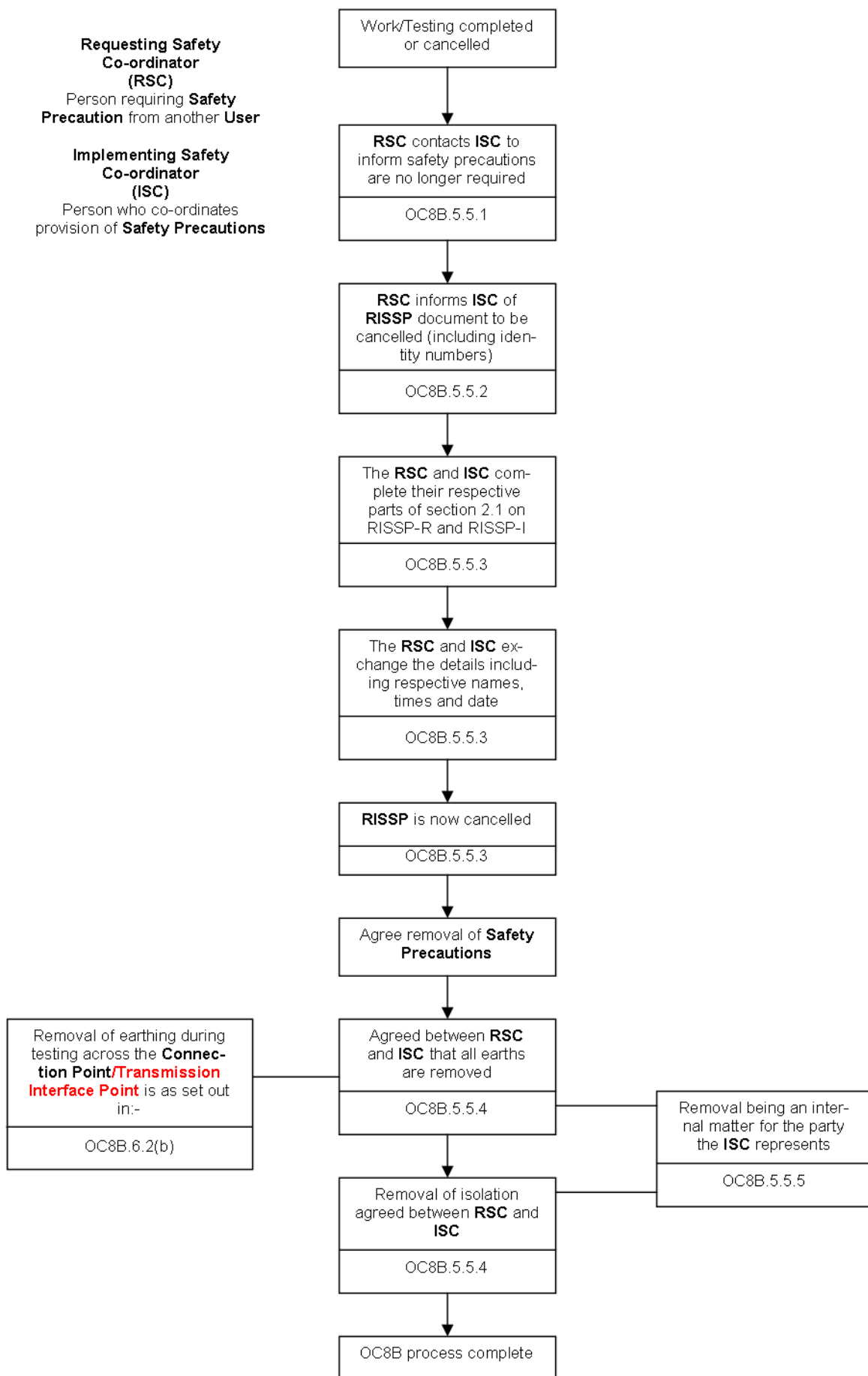

# APPENDIX C4 - PROCESS FOR WORKING NEAR TO SYSTEM EQUIPMENT

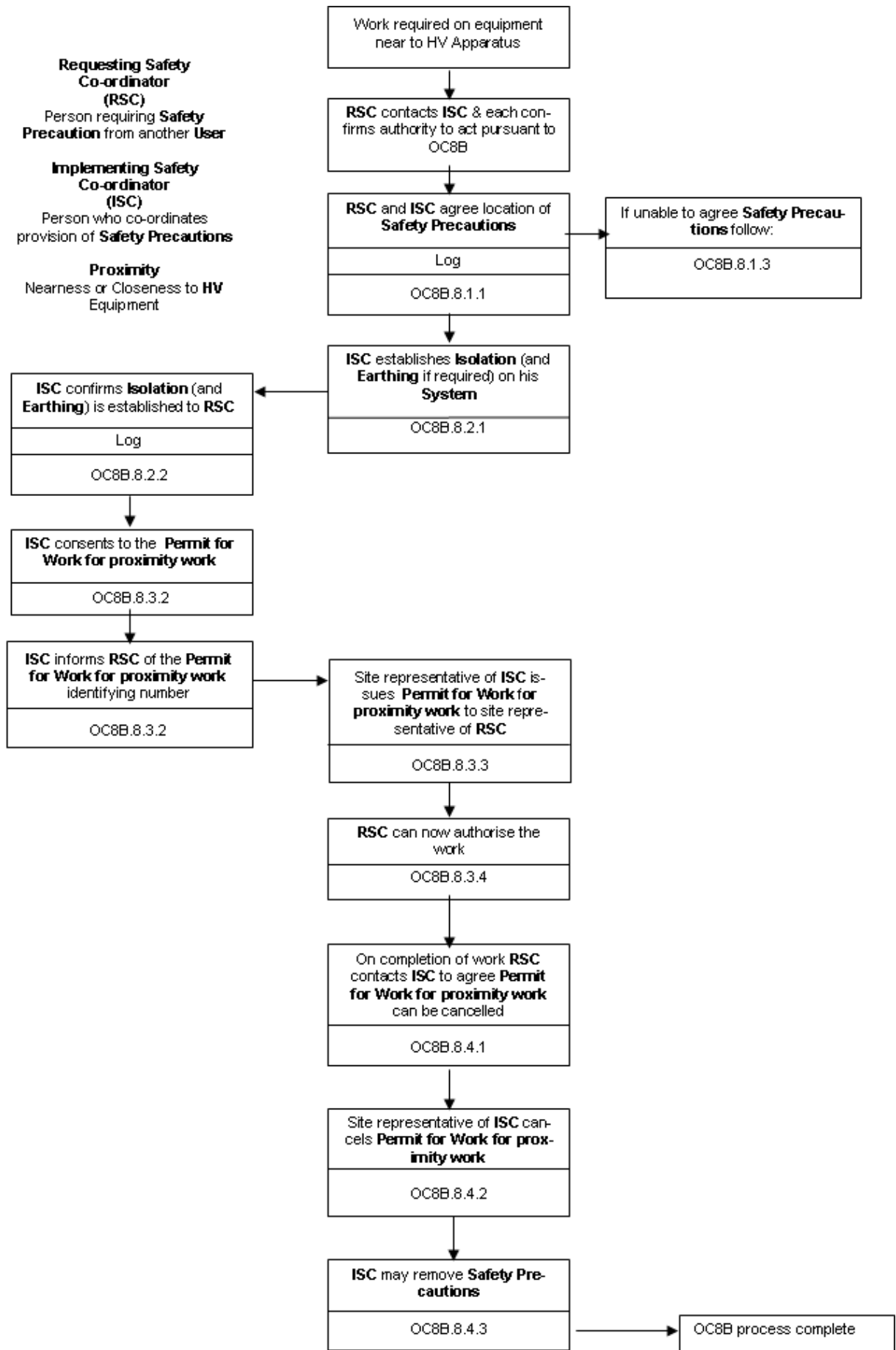



## APPENDIX D - NOT USED

**Not Used**

# APPENDIX E - FORM OF PERMIT TO WORK

Scottish & Southern Energy plc

PERMIT-TO-WORK

No. ....

## 1. ISSUE

To .....

The following High Voltage Apparatus has been made safe in accordance with the Operational Safety Rules for the work detailed on this Permit-to-Work to proceed:

.....  
.....  
.....

### TREAT ALL OTHER APPARATUS AS LIVE

Circuit Main Earths are applied at: .....

.....  
.....  
.....

Other precautions (see Operational Safety Rules 3.2.1(b), 4.6.2(c) and 5.5.3), and any special instructions:

.....  
.....  
.....

The following work is to be carried out: .....

.....  
.....  
.....

Circuit Identification Issued: Colour ..... No. of wristlets ..... No. of step bolts .....

Name: (print): ..... Signature: ..... Time: ..... Date: .....

## 2. RECEIPT

I accept responsibility for carrying out the work on the Apparatus detailed on this Permit-to-Work, applying additional earths as necessary. No attempt will be made by me, or by the persons under my charge, to work on any other Apparatus.

Name: (print): ..... Signature: ..... Time: ..... Date: .....

Circuit Identification Equipment Checked as above (Initials): .....

## 3. CLEARANCE

All persons under my control have been withdrawn and warned that it is no longer safe to work on the Apparatus detailed on this Permit-to-Work.

All gear, tools and additional earths have/have not\* been removed. The works is/is not\* complete.

All circuit identification equipment issued as above has been returned

Name: (print): ..... Signature: ..... Time: ..... Date: .....

*\* Delete where not applicable*

## 4. CANCELLATION

This Permit-to-Work is cancelled.

Name: (print): ..... Signature: ..... Time: ..... Date: .....

PERMIT FOR WORK

|     |
|-----|
| No. |
| No. |

KEY SAFE

- 1. (i) LOCATION .....
- .....
- (ii) PLANT/APPARATUS IDENTIFICATION .....
- .....
- (iii) WORK TO BE DONE .....
- .....
- .....
- .....

- 2. (i) PRECAUTIONS TAKEN TO ACHIEVE SAFETY FROM THE SYSTEM: State points at which **Plant/Apparatus** has been Isolated and specify position(s) of **Earthing Devices** applied. State actions taken to avoid **Danger** by draining, venting, purging and containment or dissipation of stored energy.
- .....
- .....
- .....
- .....
- .....
- .....
- .....
- .....
- .....
- .....

Caution Notices have been affixed to all points of isolation

- (ii) FURTHER PRECAUTIONS TO BE TAKEN DURING THE COURSE OF WORK TO AVOID SYSTEM DERIVED HAZARDS
- .....
- .....
- .....
- .....
- .....
- .....
- .....

I have confirmed with the **Control Person(s)** ..... that precautions in Section 2(i) have been carried out and that the **Control Person(s)** will maintain these until this **Permit for Work** is cancelled. I certify that the precautions in Section 2(i) together with the precautions in Section 2(ii) are adequate to provide **Safety from the System** in respect of the work in Section 1.

This **Permit for Work** must only be transferred under the **Personal Supervision** of a **Senior Authorised Person\*** .....

Signed ..... being a **Senior Authorised Person**. Time: ..... Date: .....

- 3. ISSUE
- (i) **Key Safe Key** (No.)\* ..... (ii) **Earthing Schedule\*** ..... (iii) **Portable Drain Earths** (No. off)\* .....
- (iv) **Selected Person's Report** (No.)\* ..... (v) **Circuit Identification Flags** (No. off)\* .....
- (vi) **Circuit Identification Wristlets** (No. off)\* and Colours/Symbols .....
- Signed ..... being the **Senior Authorised Person** responsible
- for the issue of this **Permit for Work** Time: ..... Date: .....

4. RECEIPT

I understand and accept my responsibilities under the ScottishPower Safety Rules as recipient of this **Permit for Work** and acknowledge receipt of the items in Section 3.

Signed ..... Name (Block Letters) .....  
 being a **Competent Person** in the employ of Firm/Dept ..... Time ..... Date .....

**TRANSFER RECORD**

| PART 1                       |           | PART 2  | PART 3                              |                      |   |           |
|------------------------------|-----------|---|-------------------------------------|----------------------|---|-----------|
| Person surrendering Document | Time Date | Senior Authorised Person receiving suspended Document * | †Person receiving reissued Document |                      | Senior Authorised Person reissuing document | Time Date |
|                              |           |   | Signature                           | Name (Block Letters) |   |           |
|                              |           | X   |                                     |                      |   |           |

†Signature of **Person** receiving re-issued Document in accordance with conditions detailed in Section 4.

5. CLEARANCE: I certify that all persons working under this **Permit for Work** have been withdrawn from, and warned not to work on, the **Plant/Apparatus** in Section 1. All gears, tools, **Drain Earths** and loose material have been removed and guards and access doors have been replaced, except for:

.....  
 .....  
 .....

Signed ..... being the **Competent Person** responsible for  
 clearing this **Permit for Work** Time ..... Date .....

6. CANCELLATION: I certify that all items issued under Section 3 have been accounted for and the **Control Person(s)\*** ..... informed of the cancellation and of any restrictions on returning the **Plant/Apparatus** to service.

Signed ..... being the **Senior Authorised Person** responsible for  
 cancelling this **Permit for Work**. Time ..... Date .....

\*N/A if Not Applicable

**< END OF OPERATING CODE NO. 8 APPENDIX 2 >**

## Grid Code Balancing Code 2

The following edits shall be made to BC2.11

- BC2.11            LIAISON WITH GENERATORS FOR RISK OF TRIP AND AVR TESTING
- BC2.11.1        A **Generator** at the **Control Point** for any of its **Large Power Stations** may request **NGET's** agreement for one of the **Gensets** at that **Power Station** to be operated under a risk of trip. **NGET's** agreement will be dependent on the risk to the **National Electricity Transmission System** that a trip of the **Genset** would constitute.
- BC2.11.2        (a) Each **Generator** at the **Control Point** for any of its **Large Power Stations** will operate its **Synchronised Gensets** (excluding **Power Park Modules**) with:
- (i) **AVRs** in constant terminal voltage mode with **VAR** limiters in service at all times. **AVR** constant **Reactive Power** or **Power Factor** mode should, if installed, be disabled; and
  - (ii) its generator step-up transformer tap changer selected to manual mode,
- unless released from this obligation in respect of a particular **Genset** by **NGET**.
- (b) Each **Generator** at the **Control Point** for any of its **Large Power Stations** will operate its **Power Park Modules** with a **Completion Date** before 1<sup>st</sup> January 2006 at unity power factor at the **Grid Entry Point** (or **User System Entry Point** if **Embedded**).
- (c) Each **Generator** at the **Control Point** for any of its **Large Power Stations** will operate its **Power Park Modules** with a **Completion Date** on or after 1<sup>st</sup> January 2006 in voltage control mode at the **Grid Entry Point** (or **User System Entry Point** if **Embedded**). Constant **Reactive Power** or **Power Factor** mode should, if installed, be disabled.
- (d) Where a **Power System Stabiliser** is fitted as part of the excitation system or voltage control system of a **Genset**, it requires on-load commissioning which must be witnessed by **NGET**. Only when the performance of the **Power System Stabiliser** has been approved by **NGET** shall it be switched into service by a **Generator** and then it will be kept in service at all times unless otherwise agreed with **NGET**. Further reference is made to this in CC.6.3.8.
- BC2.11.3        A **Generator** at the **Control Point** for any of its **Power Stations** may request **NGET's** agreement for one of its **Gensets** at that **Power Station** to be operated with the **AVR** in manual mode, or **Power System Stabiliser** switched out, or **VAR** limiter switched out. **NGET's** agreement will be dependent on the risk that would be imposed on the **National Electricity Transmission System** and any **User System**. Provided that in any event a **Generator** may take such action as is reasonably necessary on safety grounds (relating to personnel or plant) .

BC2.11.4 Each **Generator** shall operate its dynamically controlled **OTSDUW Plant and Apparatus** to ensure that the reactive capability and voltage control performance requirements as specified in CC.6.3.2, CC.6.3.8, CC.A.7 and the **Bilateral Agreement** can be satisfied in response to the Setpoint Voltage and Slope as instructed by **NET** at the **Transmission Interface Point**.