



**electricity**  
**north west**

Bringing energy to your door

*eta*

Creating efficient  
distribution networks



**LCN Fund**  
Low Carbon Networks

## Contents

Section 1:	Project Summary	1
Section 2:	Project Description	3
Section 3	Project Business Case	13
Section 4:	Evaluation Criteria	20
Section 5:	Knowledge Dissemination	29
Section 6:	Project Readiness	34
Section 7:	Regulatory Issues	41
Section 8:	Customer Impacts	42
Section 9	Successful Delivery Reward Criteria	45
Section 10:	Appendices	48
	Appendix A <i>eta</i> Technical Description	49
	Appendix B <i>eta</i> Site Selection Methodology	53
	Appendix C Organogram	57
	Appendix D Project Partner and Supplier Details	58
	Appendix E Risks and Issues Register	60
	Appendix F Project Plan	65
	Appendix G1 Business Case Analysis	69
	Appendix G2 Method and Base Case Calculations	78
	Appendix H Executive Summary <i>eta</i> Carbon Assessment	79
	Appendix I Indicative Customer Engagement Plan	85
	Appendix J Letters of Support from Project Partners	89
	Appendix K References	95
	List of Changes*	96

\*All additions to version one of the *eta* Full Submission and Appendices document are identified in red text in this version. The exceptions to this rule are the opening sentence in Sections 1.3, 2.1, 3, 4, 5, 6 & 8 as red is used to emphasise a key message; the negative numbers in Table 3.2 in the Full Submission; the negative numbers in tables on pages 74, 82 and 83; and Figures 2.2, 3.5 & 6.1.

# Low Carbon Networks Fund

## Full Submission Pro-forma

### Section 1: Project Summary

#### 1.1 Project Title:

**eta: creating efficient distribution networks**

#### 1.2 Funding DNO:

Electricity North West Limited

#### 1.3 Project Summary:

*eta is the Greek letter that represents efficiency, and efficiency is at the heart of this Project.*

eta will demonstrate a **step change** in the co-ordination and integrated operation of distribution networks in Great Britain. Utilising the most advanced technology developed today for LV network management, eta **challenges** the **current operational practices** and demonstrates how to **optimise** HV and LV networks in real time. eta marks the coming together of several technologies developed under IFI and First Tier Low Carbon Networks funding which will transform the operation of networks making them **truly responsive to customers' needs**. Enhancing existing networks in this way enables accelerated connection of clusters of Low Carbon Technologies that contribute to **emissions reduction targets**. eta is a low risk, transferrable, non intrusive method which is an **alternative first intervention** to traditional network reinforcement. The eta Method releases capacity up to **four times faster** and is **40% cheaper** than traditional reinforcement techniques for Low Carbon Technology clusters. eta's **Optimisation software** delivers **Conservation Voltage Reduction** to improve the energy efficiency of customers' electrical appliances **reducing energy** up to 3.5% per annum, and **lowering network losses** by up to 2% per annum across HV and LV networks; delivering recurring financial savings for customers, without degradation to the quality of customers' supply. In eta we will survey **customers** recruited from within the Trial areas to prove this.

The eta Solution is transferable to 64% of the Electricity North West and 72% of GB networks releasing capacity up to **2 985MW** for Electricity North West and **39 630MW** for GB; and is less carbon intensive than traditional approaches delivering an asset carbon saving of up to 93%.

Through eta, the delivery of electricity will become **more efficient**, flexible, with a real focus on minimising carbon impact whilst **enhancing supply resilience** for customers as they will become increasingly dependent on electricity as their primary source of energy.

#### 1.4 Funding

**1.4.1 LCN Funding Request (£k):** **£8 438**

**1.4.3 DNO Contribution (£k):**

**1.4.4 External Funding - excluding from NICs (£k):** **£1 926**

**1.4.5 Total Project cost (£k):** **£11 476**

## Low Carbon Networks Fund Full Submission Pro-forma Section 1: Project Summary continued

**1.5 Cross industry ventures: If your Project is one part of a wider cross industry venture please complete the following section. A cross industry venture consists of two or more Projects which are interlinked with one Project requesting funding from the Low Carbon Networks (LCN) Fund and the other Project(s) applying for funding from the Electricity Network Innovation Competition (NIC) and/or Gas NIC.**

**1.5.1 Funding requested from the Electricity NIC or Gas NIC (£k, please state which other competition):**

**1.5.2 Please confirm if the LCN Fund Project could proceed in absence of funding being awarded for the Electricity NIC or Gas NIC Project:**

- YES – the Project would proceed in the absence of funding for the interlinked Project**
- NO – the Project would not proceed in the absence of funding for the interlinked Project**

### **1.6 List of Project Partners, External Funders and Project Supporters:**

#### **Project Partners:**

Kelvatek – Low Voltage circuit breakers, link box switches and dissemination  
Siemens UK Ltd – optimisation software and dissemination  
Impact Research – customer engagement and survey activities and dissemination

#### **Project Supporters:**

TNEI – technical support  
University of Manchester – data analysis, modelling and dissemination  
Queen’s University Belfast - data analysis, modelling and dissemination  
Tyndall Manchester Climate Change Research – carbon impact assessment  
Institution of Engineering and Technology – expert technical community consultation  
Wigan and Leigh Housing Association – Registered Social Landlord  
Greater Manchester Combined Authority

### **1.7 Timescale**

**1.7.1 Project Start Date:**  
January 2014

**1.7.2 Project End Date:**  
December 2017

### **1.8 Project Manager Contact Details**

**1.8.1 Contact Name & Job Title:**  
Steve Cox, Head of Future Networks

**1.8.2 Email & Telephone Number:**  
steve.cox@enwl.co.uk  
01772 848805

**1.8.3 Contact Address:**  
Networks Strategy and Technical Support  
Hartington Road  
Preston  
Lancashire  
PR1 8LE

# Low Carbon Networks Fund

## Full Submission Pro-forma

### Section 2: Project Description

*This section should be between 8 and 10 pages.*

#### 2.1 Aims and Objectives

*The problem/challenge which needs to be resolved in order to facilitate the low carbon future*

*Making effective use of interconnection combined with voltage control to facilitate increased use of LCTs, and low carbon generation, and to reduce customers' energy consumption.*

The UK's decarbonisation journey through to 2050 will see a reduction in the carbon footprint of heat, transport and electricity generation. Current DECC forecasts suggest that there may be up to a 60% increase in total electricity demand, mostly between 2030 and 2050 and the amount of small scale embedded generation such as photovoltaic (PV) panels on domestic premises is set to increase from 26.5MW in 2015 to 18 700MW by 2040<sup>1</sup>. The substantial increase in new electricity loads from Low Carbon Technologies (LCT) such as heat pumps for heating and electric vehicles for transport coupled with the new generation will create thermal and voltage challenges for the management of high voltage (HV) and low voltage (LV) networks. Distribution network operators (DNO) must connect the new LCTs to facilitate customers' transition to a low carbon future, whilst maintaining statutory voltages, reducing network losses, managing power quality and, against a backdrop of increasing energy bills, help reduce costs to customers. DNOs would have historically employed traditional reinforcement to address the problems created by new LCTs, this option is no longer appropriate due to the high cost and associated disruption.

**The scale of the challenge is substantial;** for an estate of domestic premises with gas central heating, the LV service cables, LV mains cables and transformer are scaled to supply a peak demand after diversity of less than 2kW per property. Changing the gas heating system to an electric alternative could add 6kW per property; and when a household replaces a family car for an electric alternative, a further 3.5 or 7kW could be added. In isolation these new LCT loads may not cause an issue, but LCT clusters will create thermal, harmonic and voltage issues, with the latter being voltages below the statutory threshold due to the effect of the increased loads. Where a household is encouraged by the Feed in Tariff incentive scheme to install distributed generation, often in the form of PV panels on its roof, typically 3.6 kW of generation would be added to the property. When the new PV exports onto the distribution network there will be a voltage rise at the point of connection. Again, in isolation, PV will not cause an issue but clusters will reverse the power flow causing both thermal, harmonic and voltage rise issues.

#### *Voltage Management in a Low Carbon Future*

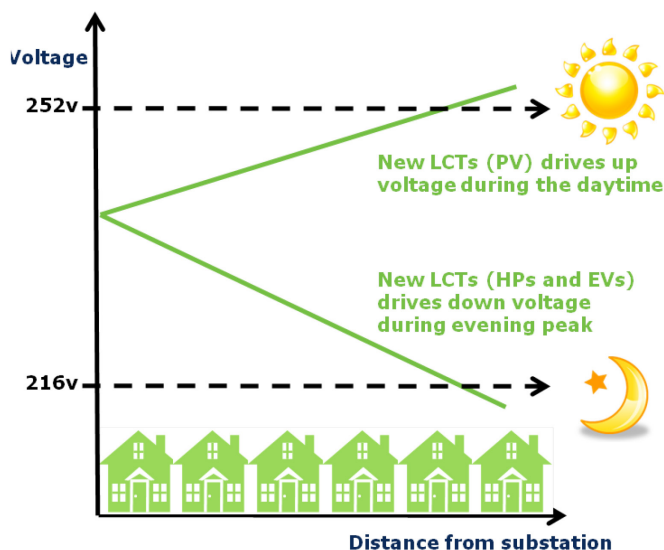
Traditionally there has been limited voltage regulation on distribution networks with none on the LV network. Figure 2.1 below shows the steady state effect on the voltage profile from the addition of a new Heat Pump and PV panels in isolation. The introduction of multiple LCTs with their differing operating regimes will result in complex network flow patterns making managing the real time network voltage within statutory limits a considerable challenge. DNOs must therefore adapt the design and operation of their networks to facilitate efficient connection of the new LCTs, whilst maintaining the power quality and network voltage within mandated limits.

#### *Efficient Distribution Networks*

As LCT volumes increase, HV and LV networks will require effective and efficient intervention techniques that are a viable alternative to traditional reinforcement to enable the networks to manage the thermal, harmonic and voltage challenges created by LCTs. **eta is a first intervention technique** which is fast, releases significant network capacity and controls network voltages and harmonics within designated limits. The innovative voltage

## Low Carbon Networks Fund Full Submission Pro-forma Project Description continued

Figure 2.1 Stylised LV network voltage profiles



management technologies used by *eta* can in addition deliver true cost savings to customers, beyond network costs; namely reducing losses and reducing energy consumption.

The recent report from the Fuel Poverty Advisory Group<sup>2</sup> highlighted the average domestic dual fuel bill is now at a record high of £1 365 pa, contributing to the economic hardship of nearly three million UK households in fuel poverty. Rather than relying on traditional reinforcement approaches, implementing innovative voltage management techniques will reduce this burden and minimise the network costs paid by all customers.

The losses associated with transporting energy across the distribution networks typically represent between 5 and 8% of energy distributed to end customers. Electricity North West reported in its Carbon Footprint Report 2011-12<sup>3</sup> that network losses equalled 1 230 GWh, approximately 5.3% of the energy distributed. These losses equated to 670 540 tCO<sub>2</sub>e. As approximately 70% of these network losses occur on the HV and LV networks, 23% and 46% respectively, voltage management techniques could make a significant contribution to reducing the network losses and therefore the carbon footprint of the distribution network.

### The *eta* Method being trialled to solve the Problem

The key theme underpinning our previous Second Tier LCN Fund Projects was to maximise the benefit to customers by greater utilisation of our existing assets. *eta* continues that principle by again proposing technological enhancements to existing assets to address the above challenges. *eta* will demonstrate how a DNO can apply innovative technology to augment the performance capabilities of existing networks, **reducing reinforcement costs, improving carbon efficiency and reducing energy costs for customers.**

Network voltages and configuration will be optimised in real time allowing a quantum shift forward in the design and operation of networks. *eta* will also show how these techniques can be incorporated with Conservation Voltage Reduction (CVR) to ensure both networks and customer appliances are operating as efficiently as possible whatever customer needs may be.

The *eta* Method combines the concepts of interconnection of networks, developed within our Capacity to Customers Project<sup>4</sup>, and voltage control, developed within CLASS<sup>5</sup>. Our previous projects focused on EHV and HV networks, *eta* extends these technologies and their benefits down the voltage levels to encompass HV and LV networks. *eta* utilises advanced real time Optimisation software to simultaneously manage all EHV, HV and LV network assets to respond to customers changing demands in the most efficient end to end manner. The three key incremental steps in the *eta* Method are the application of:

1. Co-ordinated voltage control, using on-load tap changing transformers and capacitors, across EHV, HV and LV networks;
2. Interconnecting traditionally radial HV and LV circuits and assuming control of these networks within the Control Room; and

## Low Carbon Networks Fund Full Submission Pro-forma Project Description continued

3. Real-time co-ordinated configuration and voltage optimisation of HV and LV networks. The four year *eta* Project, starting January 2014, will employ these techniques to demonstrate that a network operator can quickly release capacity and voltage headroom to facilitate the connection of LCTs and at the same time operate a cost, carbon and energy efficient distribution network. The themes of LV Network Management and Interconnection, HV and LV Voltage Control, and Network Configuration and Voltage Optimisation are the key interlinking aspects of the *eta* Method and are described below in more detail.

### LV Network Management and Interconnection

The highly variable power flows caused by some customers generating whilst others take high loads, such as vehicle recharging, will be beyond the capability of existing networks. Many of the voltage, thermal and harmonic problems, created as LCT loads and generation connect to LV networks can be significantly reduced by interconnection of LV networks.

Safely transforming a radial LV network into an interconnected LV network requires that traditional 'J' type<sup>6</sup> fuses (referred to throughout as fuses) at distribution substations and/or link boxes need to be replaced with intelligent switching devices. Our Project Partner, Kelvatek, has developed new controllable and configurable retrofit vacuum switching devices, called the **WEEZAP** and the **LYNX**, for insertion into existing LV fuse ways on LV distribution boards and in link boxes respectively. The devices can be remotely controlled allowing both sensing of feeder flows and dynamic reconfiguration of the LV network. The devices will be integrated into the automation software in Electricity North West's Network Management System (NMS) facilitating additional benefits such as network resilience. This will be the **first demonstration** in the UK of a **centralised LV network management** and automation system. Within *eta* we will develop the **safe systems of work** and associated policies and operational codes required to deploy this technology safely.

### HV and LV Voltage Control

Traditional LV electricity networks are designed and operated without voltage control capability. However as customers adopt new LCTs, these networks will face significant voltage challenges as the energy flows on these networks become complex and less predictable. We will trial the fully co-ordinated **use of capacitors** on HV and LV networks to **optimise the voltage profile** along the circuits. This will allow supply voltages to customers on the LV network to be sustained at the optimum level for **energy-efficient operation** of their appliances reducing the energy consumed by customers and on the HV network simultaneously reducing network losses. On a subset of Trial networks the learning will be extended by the incorporation of an on-load tap changing distribution transformers or a capacitor at the LV distribution board which will allow a full cost benefit comparison of the pure capacitor based management techniques against combined tap changer and capacitor techniques.

### Network Configuration and Voltage Optimisation

At the core of the *eta* Method is the ability to simultaneously optimise network configuration and voltage profiles in real time in response to customers' needs. Advanced Optimisation software will be deployed to dynamically analyse network load and generation levels and to alter both interconnected configurations and voltage profiles across HV and LV network levels. The software will allow **carbon reductions to be optimised** by directly comparing and balancing network losses and customers' energy consumption. Whilst Optimisation software is relatively mature, the derivation of the **configuration and control settings** required to realise its potential benefits across all possible network parameters will be **new learning** directly supported by our academic partners.

## Low Carbon Networks Fund Full Submission Pro-forma Project Description continued

### *The Trials being undertaken to test that the eta Method works*

The *eta* Project will trial the *eta* Method to demonstrate that the application of innovative techniques to existing assets will deliver an optimum order of interventions that can be applied to networks to **facilitate the rapid connection of LCTs**. To ensure the Trial delivers results and learning that is transferable to all UK DNOs, the *eta* Method will be trialled across a representative spectrum of network types including; dense urban, urban and rural. The Trial networks will involve 5 Primary Substations, around 10 HV circuits, 40 distribution substations and 160 LV circuits serving around 45 000 customers. The circuit selection methodology will ensure that a robust cross section of customer types and demand patterns are tested including electric heating, micro generation, small scale HV generation etc.

The *eta* Project includes a two year field Trial period during which the new technology applied to the existing network will be tested and the carbon, losses and energy savings quantified. Applying an **OFF/ ON arrangement** over defined periods, for example 24 hrs, will allow *eta* to definitively compare and assess changes between the current design and operation and the new design and operating techniques. The two year Trial period will result in a year's data of existing operation and a year's data from operation of the *eta* Method. Within the Trial period a range of tests, described later in Table 2.2 in section 2.2, will be carried out to determine the use of the new equipment and techniques in different combinations. Transition between the OFF and ON states will be managed to ensure customers are unaware of the changeover.

The Trial networks will be monitored using the WEEZAP's inbuilt monitoring functionality coupled with remote sensors to accurately record the effects of each of the Trials and tests. Our partners will analyse the resulting data to robustly establish the costs and benefits of the *eta* Method.

### *The Solution which will be enabled by solving the Problem*

The *eta* Solution is a novel method to deliver additional **benefits to customers** from existing assets, is quick to implement and will define the optimum order of a series of low cost interventions to be applied to networks as customers adopt LCTs. Many of the carbon, losses and energy benefits of *eta* can be obtained by applying the technology to existing networks now. Throughout the *eta* Project a number of outputs will be generated. The sharing of these outputs will allow any other DNO to quickly and effectively implement the *eta* Solution.

The key learning outcomes are:

1. **Installation Methodologies:** *eta* will publish detailed installation methodologies for the retrofitting of network management and voltage regulation equipment onto the Trial networks.
2. **Network Management System Configuration:** *eta* will publish the functional specifications for LV network management and automation and the new interface arrangements with the Optimisation software.
3. **Transforming LV radial networks:** *eta* will develop a methodology for interconnecting LV networks, including design considerations, the selection and deployment of voltage regulation equipment and the protection arrangements required for safe interconnected operation, particularly for fault scenarios and cold load pick up.
4. **Change proposals for design and operational standards:** *eta* will propose changes to existing industry standards, such as ENA ER P5-5 and ACE Reports Nos 3, 49 and 105, on the Design and Operation of Low Voltage distribution networks, including the optimal number of interconnection points.
5. **Safe working practices:** *eta* will publish the changes required to Electricity North



# Low Carbon Networks Fund Full Submission Pro-forma Project Description continued

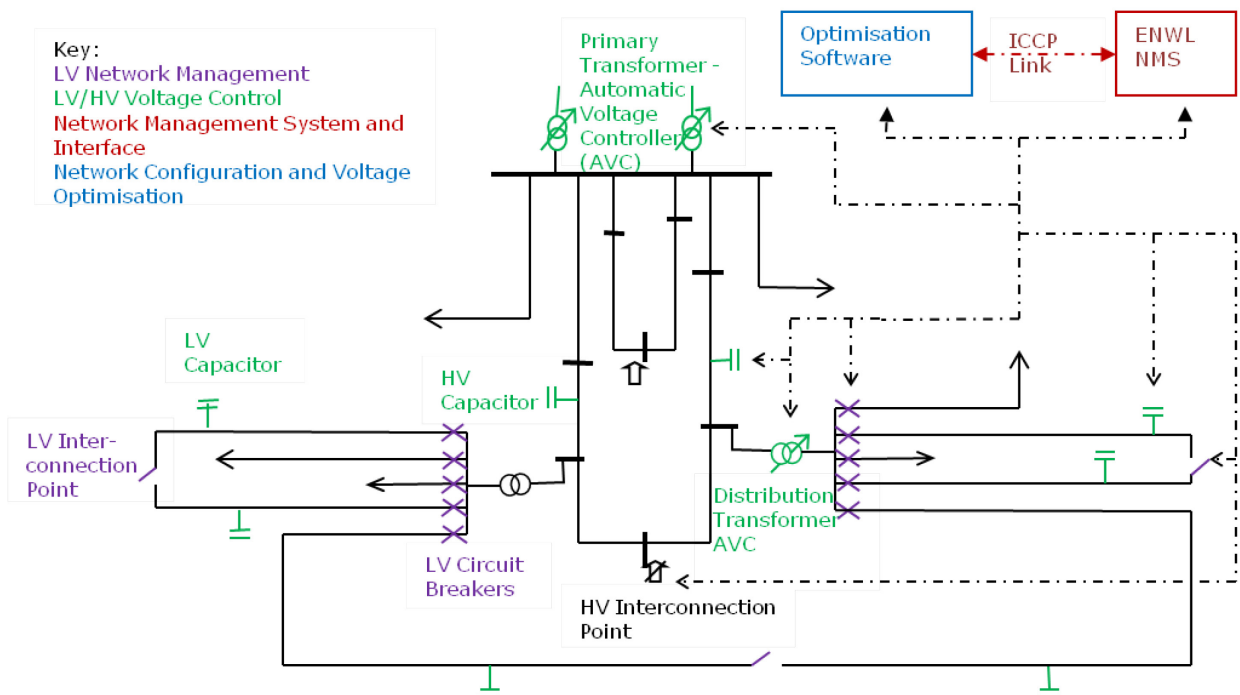
West's existing engineering policy documents, code of practices and authorisation procedures facilitating LV network management.

6. **HV and LV Voltage Control:** *eta* will deliver the results of the study on co-ordinated optimisation of voltage across HV and LV networks using on-load tap changer capabilities and capacitors.
7. **Network Configuration and Voltage Optimisation:** *eta* will publish the functional specifications, settings and configuration parameters required to optimise the operation of the distribution networks to deliver a range of specified outcomes such as carbon, losses and energy reduction.
8. **Customer engagement and feedback:** *eta* will describe the method for attracting and engaging customers in the *eta* Trial and detail their feedback, testing the hypothesis that customers will not perceive any changes in their electricity supply.

## 2.2 Technical Description of Project

The *eta* Method will integrate several technologies developed and separately tested under existing IFI or First Tier LCN Fund Projects into a common operating regime, co-ordinated and managed through Optimisation software. The technologies will be deployed on the network in line with the schematic Figure 2.2 below.

Figure 2.2 *eta* Method intervention on stylised HV and LV networks



### LV Network Management and Interconnection

The LV network configuration control will be established using Kelvatek's new retrofit LV vacuum circuit breaker, WEEZAP and retrofit remote control link box switch, LYNX. Deploying the WEEZAP in conjunction with the LYNX allows LV network interconnection and **facilitates dynamic reconfiguration**. Where a link box does not exist at a proposed interconnection point then a new link box will be installed to allow the reconfiguration capability.

## Low Carbon Networks Fund

### Full Submission Pro-forma

### Project Description continued

The WEEZAP and LYNX can be operated both locally (on-site), and remotely from Electricity North West's Control Room. In addition to remote operation the WEEZAP will provide both network monitoring (voltages, currents, power flow and harmonics) and advanced adaptive protection coupled with network fault detection capability and automatic fault reclose functions. Existing LV network fuses are not capable of meeting the challenges posed by LCT adoption, particularly under fault and overload conditions. The WEEZAP's adaptive protection can be configured to cater for LCT cold load pick up ie an extraordinarily high loading situation resulting from all connected appliances drawing power following the restoration of supply, especially during cold weather. The data collected by the WEEZAP will be used to analyse network operation during the Trials.

#### HV and LV Voltage Control

*eta* will simultaneously manage the Primary transformer Automatic Voltage Control (AVC) system, the HV and LV network capacitors, the distribution transformer AVC and HV and LV interconnection points in order to deliver the optimal network configuration and voltage profiles for carbon, losses and energy savings in real time. Where possible the Primary transformer AVC will be controlled using Voltage Controllers already deployed and funded under CLASS.

The operation of the HV and LV capacitors will be based on voltage set-points rather than power factor control which is usual with capacitors. The controllers for the capacitors will operate in two modes: when communications are available they will carry out close/ open commands issued by the NMS; when communications are lost they will switch the capacitance based on the voltage detected on the network at the connection point. The Optimisation software will issue both switching instructions and target voltage set-points to all these devices as the demand (from connected load or generation) changes on the network. This dual mode is critical to enable safe operation in the event of a communications loss.

#### Network Management System and Interface

For *eta* to be deployed our NMS will be configured to include the new devices required on the Trial LV networks. These Trial LV networks will be managed by our Control Room throughout the Trial to ensure that all equipment operates within design parameters and customer supply voltages are maintained within statutory limits.

There will be a requirement to label the Trial networks, particularly the distribution substations and associated LV circuits and adequately brief all relevant staff to ensure that they are aware of the new operating regime. As the physical network is modified, the representative virtual diagrams in the NMS will be updated and the new information shared with the Optimisation software. The NMS will interface with the Optimisation software using a standard Inter Control Communications Protocol (ICCP) link which will be developed as part of *eta*. The ICCP link used for *eta* encompasses and extends the link established under the CLASS Project.

#### Network Configuration and Voltage Optimisation

The Optimisation software will assimilate voltage measurements from key points on the HV network, distribution substation LV busbars and along LV circuits to make decisions on how to regulate the network voltage. In order to provide an appropriate voltage to the customer, whilst minimising operational carbon, the software will decide whether to:

- Alter the target voltage for the tap changers on the Primary transformers;
- Add or remove capacitance to the HV network;
- Alter the HV network running arrangement;
- Alter the target voltage for the tap changers on the distribution transformer;

# Low Carbon Networks Fund

## Full Submission Pro-forma

### Project Description continued

- Add or remove capacitance to the LV network; and
- Alter the LV network running arrangement.

The Optimisation software will apply any combination of the above depending on what is suitable to ensure that the **optimum voltage is delivered to the customer** and end to end carbon is minimised. It will also direct the transition between the existing and new state in the Trial to ensure no effects are noticed by customers.

### 2.3 Description of design of Trials

#### Scope of *eta*

*eta* re-evaluates the three efficiency criteria of cost, carbon and energy with respect to the design and operation of HV and LV networks. In developing *eta* TNEI reviewed the use of network interconnection techniques and voltage control using capacitors previously used by other network operators around the world, including the USA and Australia. These techniques have never before been combined in an end to end application on a UK configuration distribution system. The current design and operation of GB HV and LV networks is highly cost efficient, but the cost of developing these networks to accommodate high volumes of LCTs using traditional techniques is prohibitive. *eta* aims to combine the various established voltage control techniques in an end to end optimised solution to deliver a balanced set of cost, carbon and energy efficiencies across HV and LV distribution networks. These techniques will be employed across the three geographical locations of city, town and country in order to understand their application in the range of different network types and customers representative of GB.

#### *eta* Site Selection Methodology

The *eta* Trial sites will be selected during the Project. The site selection methodology outlined below, has been developed by TNEI and Electricity North West, and the full site selection methodology is detailed in Appendix B. In order to determine the costs for the new design and operation of the HV and LV networks we have identified three preliminary Trial locations in Manchester, Wigan and Wigton. We are developing relationships with Registered Social Landlords in these three areas as we wish to maximise the use of the techniques to benefit customers likely to be classified as in fuel poverty. The following aspects are applied to the site selection criteria:

- Voltage levels: to maximise the learning outcomes and applicability to other GB DNOs;
- Circuit types: to provide an understanding of the operation of interconnection and voltage control in rural, urban and dense urban contexts;
- Customer types: a representative sample of load and generation connections;
- Low Carbon Technology uptake: presence of known LCT to demonstrate effect and full potential of the *eta* Method;
- Physical Constraints: availability of interconnection points and space required for new equipment.

#### *eta* Hypotheses

*eta* will test the following hypotheses (*in the identified Workstreams*):

1. The *eta* Method will deliver a reduction in customers' energy consumption (*Research Workstream*).
2. Customers within the *eta* Trial area will not perceive any changes in their electricity supply (*Customer Workstream*).
3. The *eta* Method will have no adverse effects on customers' internal installation or appliances (*Research Workstream*).
4. The *eta* Method is faster to apply than traditional reinforcement, supports accelerated LCT connection and reduces network reinforcement costs (*Research Workstream*).

## Low Carbon Networks Fund Full Submission Pro-forma Project Description continued

5. The *eta* Method facilitates the prioritisation of the range of solutions across differing LCT adoption scenarios based on a cost benefit analysis to accommodate customers' uptake of LCTs (*Research Workstream*).
6. The *eta* Method will deliver a reduction in overall losses through network configuration and voltage optimisation (*Research Workstream*).
7. The *eta* Method facilitates real time control of a portfolio of LV network solutions, using retrofit technologies with application combined or in isolation (*Technology Workstream*).

### *eta* Trials

The *eta* Trials will take place over a two year period. The Trial design for *eta* is to operate the distribution networks as normal for a defined period and then apply the Method for the same length of time. This OFF/ ON arrangement, an example of which is shown below in Table 2.1, applied over a two year period will result in a year's worth of network data of existing operation and a year's worth of data from the Method operation and allows the change between the operating regimes to be compared and analysed. The OFF/ ON Trial design **can be applied without customer intrusion and isolates the effect of the *eta* Method from customer behaviour. This will provide data that demonstrates the difference between energy consumption during application of the Method and energy consumption during normal operation. This information then enables a calculation of the aggregated consumption data to evaluate customers' energy savings.**

Table 2.1 *Indicative eta Trial regime showing daily application*

Year	Month	Week	Mon	Tue	Wed	Thu	Fri	Sat	Sun
X	a	1	On	Off	On	Off	On	Off	On
X	a	2	Off	On	Off	On	Off	On	Off
X	a	3	On	Off	On	Off	On	Off	On
x	a	4	Off	On	Off	On	Off	On	Off

Test regimes

On

Off

American studies of Conservation Voltage Reduction suggest the change over period between regimes should occur at minimum demand ie around 2am for non-electrically heated areas with low PV penetration. The design of the customer survey (see Section 8) takes into consideration the need to survey customers **in order to prove Hypothesis 2; "Customers within the *eta* trial area will not perceive any changes in their electricity supply"**. In *eta* we will also record and track the following data so that any anomalies in the network metered data can be explained:

- Network performance data (eg faults, customer complaints, voltage complaints etc) to understand extraneous impacts;
- Monthly consumption of local Grid Supply Point/ Bulk Supply Point to check whether the Trial networks are seeing the same local consumption patterns/ trends;
- Standard weather data (hourly observations of temperature, wind speed, cloud cover, precipitation and humidity at north and south weather stations) for normalising the recorded consumption data; and
- Economic data (eg GDP, salaries, electricity & gas prices and RPI) to understand extraneous changes in behaviour from economic activity, using metrics appropriate to the north west of England where possible.

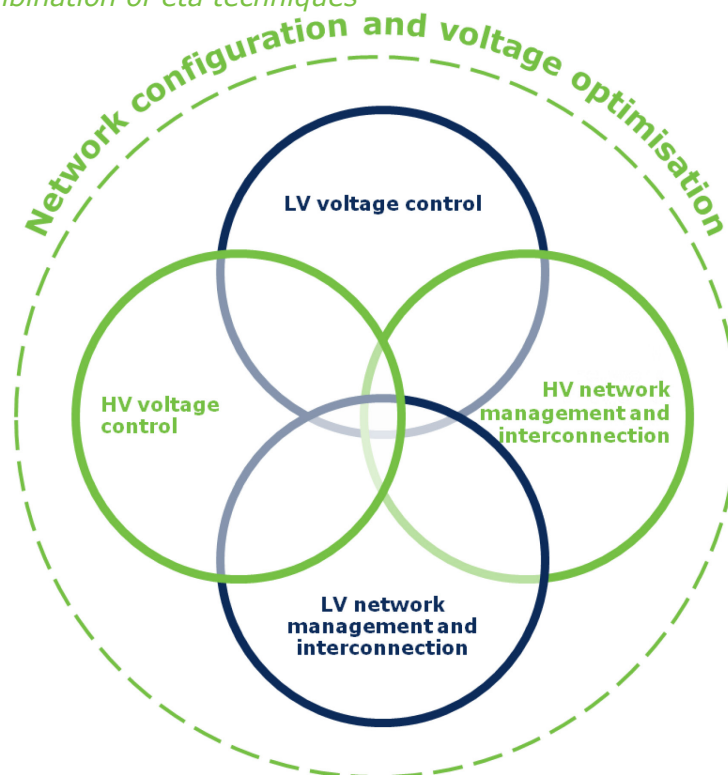
## Low Carbon Networks Fund Full Submission Pro-forma Project Description continued

### *eta* Test Regimes

The tests, illustrated diagrammatically below in Figure 2.3 and described overleaf in Table 2.2, will be carried out to determine the application of the equipment in different combinations. Across the *eta* Trial networks the full range of *eta* interventions will be tested, so that the full effects of the *eta* Method can be disaggregated into its component parts. The test regimes and the execution methodology will be developed fully prior to the Trial period. In *eta* we will quantify the benefits of the new design and operating arrangements of HV and LV networks and determine the:

- Capacity and voltage headroom released and the quantities of new LCTs that could be connected;
- Economic justification and carbon benefits;
- Determine the optimisation algorithm settings to deliver losses reduction and energy reduction from Conservation Voltage Reduction;
- Quantum of customers' energy reduction, from application of Conservation Voltage Reduction methodology, and understand the variation of the consumption reduction between times of day, days of week and seasons;
- Effect on customers' power quality, internal electrical installations (ie wiring and fusing) or appliances;
- HV and LV losses reduction;
- Confirm settings required to manage cold load pick-up;
- Interruption Incentive Scheme benefits;
- Safety benefit of removing the need for manual operation of live LV network equipment offered by the WEEZAP and LYNX; and
- Fault response cost reductions arising from the in-built fault detection and localisation capabilities of the WEEZAP.

Figure 2.3 Combination of *eta* techniques



# Low Carbon Networks Fund

## Full Submission Pro-forma

### Project Description continued

Table 2.2 *eta* Trial and Test Regimes

Technique	Test regimes
Trial: OFF/ON Trial period: Two years	
LV Voltage Control	1. On-load tap changing distribution transformer only; or
	2. On-load tap changing distribution transformer and capacitor(s) on LV circuits; or
	3. Capacitors at distribution substation only; or
	4. Capacitors at distribution substation and on LV circuits; or
	5. Capacitor(s) on LV circuits only.
LV Network Management and Interconnection	1. LV radial circuits; or
	2. LV interconnected circuits.
HV Voltage Control	1. Voltage Controllers at Primary substation only; or
	2. Voltage Controllers at Primary substation and capacitor(s) on HV circuits.
HV Network Management and Interconnection	1. HV radial circuits; or
	2. HV interconnected circuits.
Network Configuration and Voltage Optimisation	1. Losses reduction; and/ or
	2. Energy consumption reduction.

#### 2.4 Changes since Initial Screening Process (ISP)

The scope of the *eta* Project has changed in the following ways since the submission of the Initial Screening Pro-forma:

- The LCN Funding requested for *eta* has decreased to £8.4 million;
- The creation of Trial design and the management of the Trial will be undertaken by the *eta* Project team, due to the quoted costs received from tenders; the Trial design will be peer reviewed prior to the Trial starting;
- Monitoring will be located on the network to measure the effects of the *eta* Method not in customers' premises as previously indicated; and
- Within *eta* we have chosen not to use the communications infrastructure offered by a third party provider as the expected costs above business as usual costs do not provide value for money.

# Low Carbon Networks Fund

## Full Submission Pro-forma

### Section 3: Project Business Case

*This section should be between 3 and 6 pages.*

*The eta Solution has the potential to deliver a cost effective and quick series of first intervention methods to facilitate the connection of LCTs.*

The business case for *eta* is that it can be the **first intervention** and in the majority of cases the only intervention to develop distribution networks to facilitate the rapid and low cost connection of LCTs, assisting the UK transition to a low carbon economy. *eta* explores the potential of transforming existing radial LV networks into safe and reliable interconnected LV networks whilst simultaneously optimising the network voltage profile through the use of capacitors to release capacity and voltage headroom and legroom. The *eta* Method delivers **DUoS cost efficiencies for all customers** and **reduces the carbon footprint** for all GB energy customers.

#### Customer Benefits

The University of Manchester, S & C Europe, the Tyndall Manchester (Centre for Climate Change Research), Parsons Brinckerhoff, TNEI and Electricity North West have collectively undertaken modelling work on the *eta* Method. The results from these studies are described below and included in Appendix G. The analysis performed on a typical network model indicates that *eta* is both viable and beneficial. The *eta* Project will extend the analysis to live networks and encompass the full range of network types encountered in the UK.

#### Financial Benefits

The principal benefit of the *eta* Solution is that it offers a **rapid and cost effective intervention** to facilitate the connection of LCTs. In the near term (5 to 15 years) *eta* can quickly alleviate problems caused by early adoption of LCTs appearing in clusters. *eta* offers an alternative to traditional reinforcement as HV and LV interconnection coupled with voltage control releases capacity and voltage head/ legroom thereby deferring traditional reinforcement for a period of time and in many cases avoiding reinforcement completely.

In order to compare the *eta* Method against traditional reinforcement techniques TNEI modelled, using its IPSA modelling tool, the Dunton Green substation's LV network and the associated HV network considering the scenarios of: 1) clustering of PV with 75% penetration; 2) clustering of EVs and HPs with 60% penetration; and 3) High penetration of EVs, PVs and HPs (Scenario 3 of the Transform model). The intervention scenarios were modelled over a 25 year period nominally starting from the assumed cluster appearance in 2015. The modelling compared the relative capital expenditure, network losses and the additional benefit from the application of the *eta* Method's Conservation Voltage Reduction. Figures 3.1 and 3.2 overleaf compare the cash savings of the *eta* Method over and above the traditional reinforcement approach for the three elements of capital expenditure, losses and CVR for the clustering of demand and generation respectively. In both cases the capital expenditure is less for the *eta* Method compared with traditional reinforcement and there is an annual benefit from the application of CVR which is less from the generation cluster scenario as the overall demand on the network is less.

For the **generation** cluster there is a losses benefit under *eta* whilst this is reversed in the **demand** cluster with the losses under *eta* higher compared with traditional reinforcement. The TNEI modelling assumed that the system would maintain customer voltages close to the minimum for optimum CVR performance. In the Trial and a live implementation the optimum voltage would be that which gave the lowest overall energy. For example at times of low demand and maximum generation the voltage would be run as **low** as possible **allowing maximum DG export**, conversely at times of high demand and low generation the voltage would be run **higher**. This end to end optimisation means that *eta* would be beneficial across the load cycle verses a traditional solution. These charts show the effect of

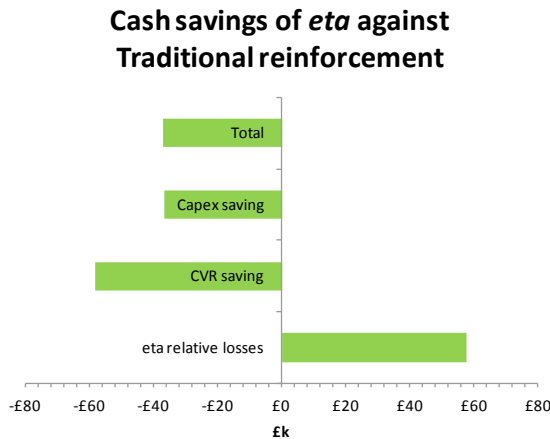
# Low Carbon Networks Fund

## Full Submission Pro-forma

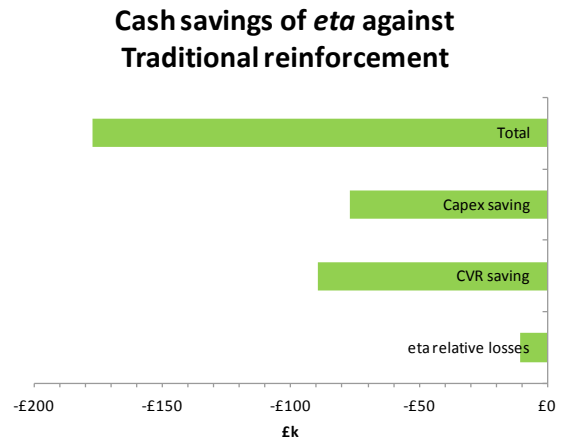
### Project Business Case continued

the annual losses and CVR has on cash flows across the 25 year period modelled; with losses valued at 4.8p/kWh and energy at 13p/kWh.

*Figure 3.1 eta cash savings for demand cluster intervention*

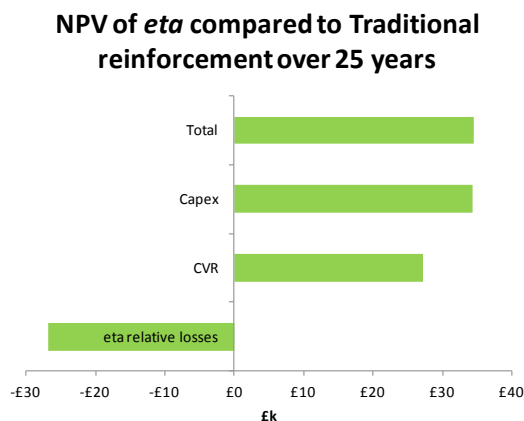


*Figure 3.2 eta cash savings for generation cluster intervention*

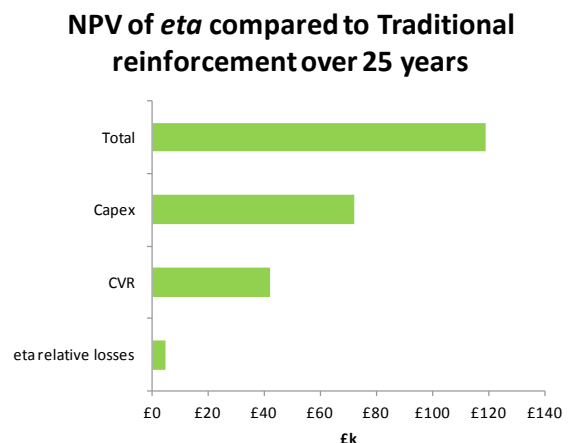


Figures 3.3 and 3.3 below compare the net present valuation of the eta Method over and above the traditional reinforcement approach for the three elements of capital expenditure, losses and CVR for the clustering of demand and generation respectively. In both cases the net present valuation for the eta Method is over and above the traditional approach, even in the case of the demand led reinforcement scenario where losses increase. These charts show the effect of the annual losses and CVR has on cash flows discounted at 6.7% across the 25 year period modelled; with losses valued at 4.8p/kWh and energy at 13p/kWh. Arguably the losses and CVR benefit should be modelled using the social time preference rate of 3.5%.

*Figure 3.3 NPV analysis for demand cluster intervention*



*Figure 3.4 NPV analysis for generation cluster intervention*



The eta intervention in the demand and generation clusters shows positive financial benefit across the modelled period and would be used as a Solution to address the Problem. Network operators will continue to see generation clusters from the introduction of the Feed-in-Tariff incentive regime and expect to see demand clusters from the introduction of



## Low Carbon Networks Fund Full Submission Pro-forma Project Business Case continued

the Renewable Heat Incentive. The *eta* intervention in the demand cluster delivers positive financial benefit compared with traditional reinforcement but the increased annual losses compared to traditional techniques may warrant further intervention. The **flexibility** of the *eta* Method offers additional financial benefits as it provides **optionality**. The above modelled cases show that the *eta* Method compares favourably against traditional reinforcement when significant clusters appear on networks, but there is significant uncertainty on how LCT penetration will develop across distribution networks. The interconnection and voltage regulation techniques of the *eta* Method can be applied in combination or separately as required, contingent on the network conditions. In some cases the *eta* Solution will be the first and final intervention as shown above and in other cases it provides a time extension and optionality before additional LV network or smart assets are required to cater for further LCT connections. At this decision point a DNO can choose to reinforce with traditional techniques, deploy complementary technologies such as storage with or without the *eta* Method, contingent on the network conditions. Combinations of the *eta* Method with technologies such as storage allow smaller lower cost storage to be used to provide a final intervention solution. Where *eta* is not a permanent or retained solution the *eta* technology can be re-deployed. This is a significant benefit as the WEEZAP and LYNX switches can be easily re-deployed allowing the interconnection of new LV circuits.

Figure 3.5 Network scenarios

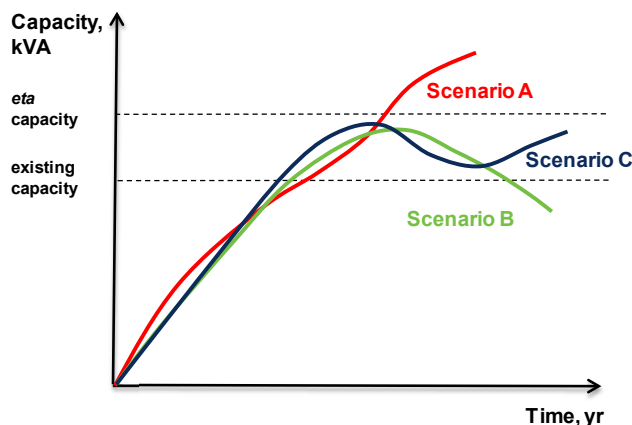


Figure 3.5 below shows the possible scenarios for potential re-deployment of *eta* technology: scenario A shows the continued growth of demand above available capacity; scenario B shows demand dropping back to or below original levels; and scenario C shows demand fluctuating between capacity levels. There may be an opportunity to re-deploy the WEEZAPs and the LYNXs in scenarios A and B, assuming a further intervention is required in scenario A and the *eta* intervention is longer required in scenario B.

Each re-deployment saves ██████, for each LV interconnected pair of circuits.

Assuming scenarios A, B and C occurs 50%, 20% and 30% on average, for 100 LV interconnected circuit pairs the re-deployment savings could be a minimum of ██████ to a maximum of ██████ (undiscounted).

In the medium to longer term (in RIIO-ED2 and beyond) the *eta* Solution can be rolled out across Electricity North West's network as the design and operation intervention standard to facilitate the unfettered adoption of customers' LCTs.

The use of **advanced circuit breaker technology** in LV networks, coupled with the automation software within our Network Management System means that as customers become more reliant on electricity for all their household needs through LCT adoption, our networks become more reliable. The *eta* technology will restore the electricity supply quickly ie within three minutes for transient LV network faults; and the cold load pick-up functionality will ensure that following a lengthy (greater than one hour) HV or LV fault, customers will not experience a further outage from the operation of distribution fuses.

Assuming the *eta* Trial networks experience the same Electricity North West transient fault rate then around 240 customers in the *eta* Trial networks will experience on average 58 minutes less time without supply from transient faults per annum, equating to £320 per

## Low Carbon Networks Fund

### Full Submission Pro-forma

### Project Business Case continued

annum in IIS terms or £569 per annum assuming an average willingness to accept value of loss load of £9.88/kWh<sup>7</sup>. In the future when there is more LCT demand on LV circuits following the restoration of an HV fault, a fuse could operate leaving customers without supply for up to an hour. With the WEEZAP's adaptive protection functionality the cold load pick up would be managed and customers would not experience an extended period without supply. For a single LV circuit with 20 customers per phase the IIS savings would £460 per annum for a single fuse operating and being restored on average an hour later.

The management of the voltage profile along the LV circuits allows customers' PV installations to deliver the maximum FiT income using the existing local network assets. If, due to an increased voltage situation, a customer's PV installation stops operating for a hour at midday the lost FiT and export income would be around £0.75. If this situation occurred everyday over the summer period then the customer could be losing as much as £70. *eta* will avoid this customer loss.

#### Carbon Benefit

Tyndall Manchester for Climate Change Research assessed the carbon impact of the *eta* Method using the TNEI modelling results. Table 3.1 below shows the asset carbon savings for the generation and demand cluster scenarios which indicates *eta* is **up to 15 times less carbon intensive** as it employs less network assets than traditional reinforcement to release an equivalent network capacity.

Table 3.1 Asset carbon between *eta* and traditional methods

Asset Carbon (tCO <sub>2</sub> e)				
Scenario	<i>eta</i>	Trad	Saving	<i>eta</i> as % of Conv
Generation	3.9	58.3	54	6.7%
Demand	3.3	24.8	21	13.3%

In the Demand clusters scenario, it is shown in Table 3.2 below that the conventional reinforcement provides a greater emissions reduction than the *eta* Method in terms of losses, and over time this outweighs the savings on assets. The net break-even point, under this combination of parameters is between 2025 and 2027 dependent upon the inclusion of CVR benefits.

Table 3.2 Operational carbon between *eta* and traditional methods

Carbon Impact (tCO <sub>2</sub> e)		
Scenario	without CVR	with CVR
Generation	-90	-321
Demand	432	282

Table 3.3 updates the net present values for the *eta* Method and traditional method including the cost of carbon and applying the social time preference rate of 3.5% to losses and CVR.

Table 3.3 Cost benefit analysis

Cost Benefit Analysis - NPV including cost of carbon						
Scenario	<i>eta</i>	Traditional	Benefit	<i>eta</i> +CVR	Traditional	Benefit
Generation	£114,989	£198,263	£83,274	£50,028	£198,263	£148,235

# Low Carbon Networks Fund

## Full Submission Pro-forma

### Project Business Case continued

Demand	£95,336	£80,141	-£15,195	£53,269	£80,141	£26,872
--------	---------	---------	----------	---------	---------	---------

#### Operational Benefits

*eta* provides a robust and safe means of operating networks supplying LCT clusters. The new LV network control functionality gives visibility of LV network operation which will assist Electricity North West to deliver **improved fault restoration performance**, particularly the **resilience** to manage cold load pick-up. The *eta* Solution is a flexible series of interventions which can be deployed quickly as challenges develop fulfilling the aim of improving the utilisation of existing assets. In addition, voltage regulation using capacitors improves the power factor of HV and LV networks, **fully utilising every kVA of network capacity**.

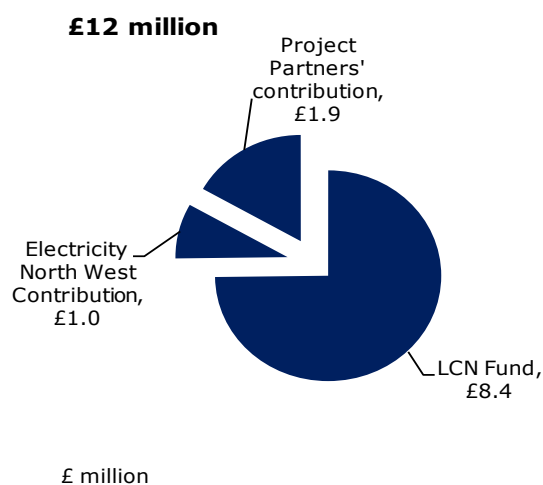
#### Non Quantified Benefits

*eta* is the first demonstration project in the UK, funded by the LCN Fund, to develop the electricity industry knowledge of Conservation Voltage Regulation and explore the benefits that can be delivered to distribution customers. The learning provides evidence for the RIIO ED2 discussions on the potential incentives and obligations on energy companies for increasing customers' energy efficiency to assist the UK's carbon targets. Undertaking the *eta* Project will enhance our knowledge of customer engagement and support our customers' low carbon journey. The use of CVR is not directly incentivised by the RIIO-ED1 structure however there are second order incentives through losses, social and efficiency obligations. Once CVR has been proven to be beneficial and the benefits quantified future incentive structures can be considered.

#### Costs & Assumptions

By working closely with our Partners in the scoping of the *eta* Project and through a robust standardised financial costing methodology, Electricity North West has been able to capture and continually refine the Project costing model. The lessons learnt from creating and costing both C<sub>2</sub>C and CLASS Projects have enabled Electricity North West to develop an accurate cost model offering excellent value for money for customers and stakeholders. Figure 3.4 shows the total cost of *eta* is £12 million with the funding breakdown. A significant proportion of *eta* will be funded by the Project Partners.

**Figure 3.6** *eta* Funding Proposal



Electricity North West will share learning between *eta* and a £20 million project funded by the Japanese Development Organisation, NEDO, researching the installation, operation and development of Japanese heat pump technology for roll out in Europe. The Smart Communities project, supported by Greater Manchester Combined Authority and two local Registered Social Landlords will install 300 Heat Pumps in social housing properties within the Wigan and north Manchester areas. The Trials phase for both projects cross-over and so an opportunity exists to influence the test regimes for both projects and

# Low Carbon Networks Fund

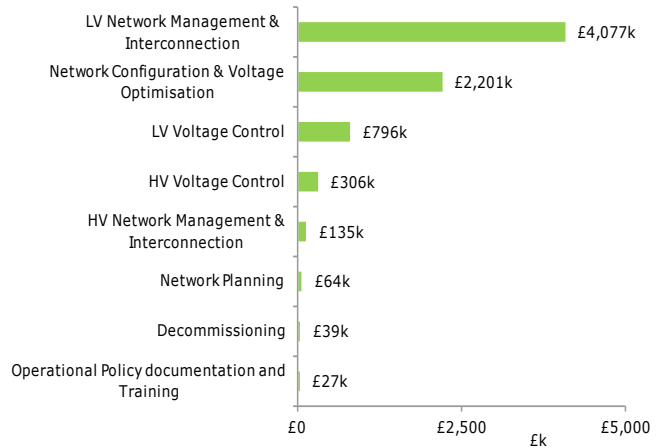
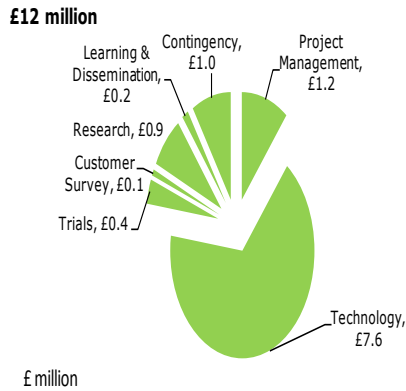
## Full Submission Pro-forma

### Project Business Case continued

share the learning gained.

Figure 3.5 shows how the total has been broken down into the main cost segments, with the Technology Workstream costs broken out separately.

**Figure 3.7 eta costs breakdown**

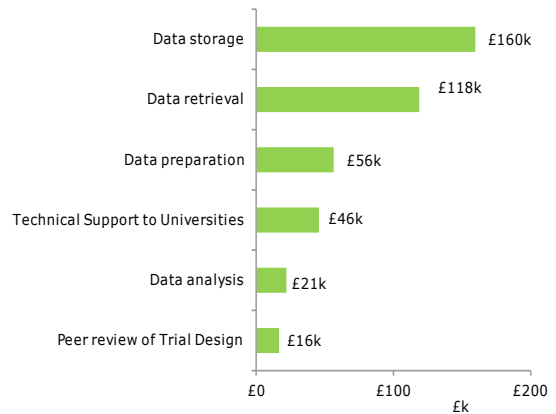


Figures 3.8 to 3.11 show the cost breakdown for the Customer, Trials, Research Workstreams and the contingency costs respectively.

**Figure 3.8 eta Customer Workstream costs**

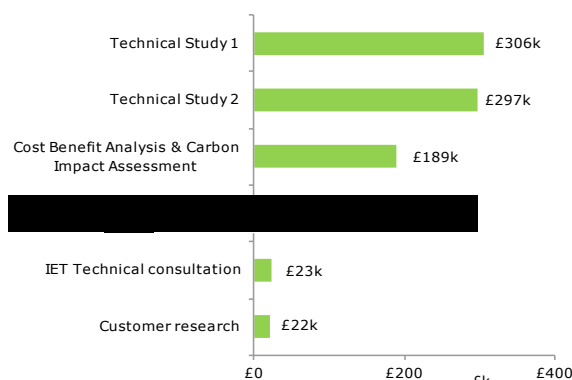


**Figure 3.9 eta Trials Workstream costs**

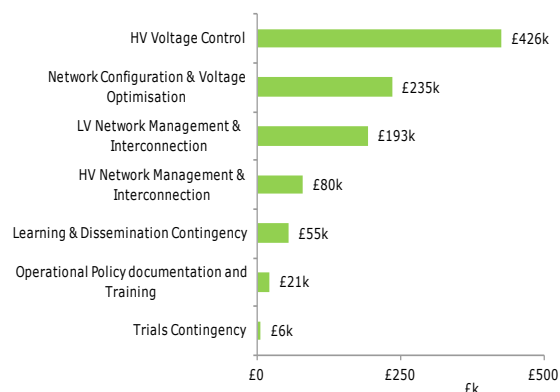


# Low Carbon Networks Fund Full Submission Pro-forma Project Business Case continued

**Figure 3.10 eta Research Workstream costs**



**Figure 3.11 eta contingency costs**



In developing the *eta* Project costs the following key assumptions have been made:

- All costs include RPI;
- RPI rates are those issued by Ofgem, and
- Project funding includes a 8.85% contingency.

### Electricity North West Direct Benefits and Contribution

The potential Direct Benefits resulting from undertaking the *eta* Project would appear in the following areas:

1. the replacement of Automatic Voltage Control schemes in Primary Substations, and link boxes, LV distribution boards, distribution transformers in the Trial areas; and
2. the deferment of network reinforcement in the Trial areas.

A methodology was developed to calculate the Direct Benefits for each category and the value of the Direct Benefits has been calculated as £22 861.

As part of the LCN Fund mechanism Electricity North West is responsible for contributing 10% of the total Project cost, which represents a contribution of £0.955 million. The above commentary details that £23k of this would be funded through Direct Benefits and remainder straight from Electricity North West.

The *eta* Project has been through the Electricity North West internal approval process and has been signed off by the Board.

## Low Carbon Networks Fund Full Submission Pro-forma Section 4: Evaluation Criteria

*This section should be between 8 and 10 pages.*

**(a) Accelerates the development of a low carbon energy sector & has the potential to deliver new financial benefits to future and/or existing customers**

*eta* will trial the application of the interconnecting networks with co-ordinated voltage control, using on-load tap changing transformers and/or capacitors on HV and LV networks and in real-time the network configuration and voltage will be optimised for the benefit of customers. The *eta* Solution has the potential to be the first and potentially the final intervention for responding to LCT clusters.

In this section and with further supporting material in Appendices G (Business Case Analysis and Method and Base Case Calculations) and H (Carbon Impact Assessment), we quantify the impact that the *eta* Solution could have.

*eta Project:* The *eta* Trials involves 5 Primary substations, around 10 HV circuits, 40 distribution substations and 160 LV circuits across city, town and country locations. In the *eta* Project, Electricity North West could release 9.16MW of network capacity across the 160 LV circuits by application of the *eta* Solution to address LCT clusters, assuming equal demand and generation led reinforcements. Releasing this capacity is up to **four times faster and 40% cheaper** than applying traditional reinforcement techniques. The *eta* Method is less carbon intensive than traditional approaches delivering an **asset carbon saving** of between 86% and 93%.

*Electricity North West:* Roll out across the Electricity North West network could deliver 2 985MW and reduce the traditional reinforcement costs and planning time involved with overlaying cables and/or potentially the installation of new distribution substations for managing LCT clusters. The *eta* Method of interconnecting networks can be applied very quickly and so can be used as a **tactical response to the rapid adoption of LCTs**. Assuming equal demand and generation led reinforcements, Electricity North West could save 370 000 tCO<sub>2</sub>e of asset carbon if *eta* is deployed across its network.

*Great Britain:* Roll out of the *eta* Solution across GB could release 39 630MW and significantly reduce the time to facilitate the connection of LCT. When deployed across GB ***eta* could save 4.9 million tCO<sub>2</sub>e of asset carbon**.

### **A roll-out of *eta* across GB - accelerated contribution to Carbon Plan**

The government's Carbon Plan addresses the challenge of decarbonisation by highlighting the three themes of 'Generating our electricity', 'Heat for our home and businesses', and 'Powering our cars and vehicles'. To meet the Carbon Plan more low carbon electricity generation will be needed to meet increased demand from new electric heat and transport systems. These changes are at risk of delay due to the time and cost of network reinforcement.

*Reform of the electricity grid* - The increase in electricity generation and the change in the generation mix will make system control more complex and demanding. The *eta* Project accelerates the reform of the electricity networks in two ways: firstly it **facilitates the quick connection** of low carbon generation and demand; and secondly the new voltage regulation regimes in *eta* will demonstrate how distribution networks can **help reduce the energy bills of customers**. Through *eta*, research and analysis will determine whether distribution network operators can improve the cost, carbon and energy efficiency of the distribution networks and maintain an economic and secure electricity system; through the provision of these lower cost and lower carbon options.

*Secure, sustainable low carbon electricity* - *eta* **accelerates the creation of a secure and sustainable low carbon electricity sector** in the following ways: firstly the *eta* Solution uses reliable and proven technology and assets in a novel way to improve the network's

## Low Carbon Networks Fund Full Submission Pro-forma Evaluation Criteria continued

efficiency and the security and continuity of supply to DNO customers; and secondly *eta* facilitates the connection of low carbon generation whilst reducing the financial and carbon costs currently required to reinforce the network in providing such additional capacity.

### The potential for replication across GB

TNEI modelled the interventions required at the Dunton Green substation to facilitate the connection of LCT clusters for the *eta* Method and traditional methods, specifically for PV (generation) and HPs and EVs (demand) clusters. TNEI proposed the replication of the *eta* Method on the Electricity North West and GB networks should be determined based on the number of LV circuits it can be practically applied to, using data from the Transform model. The applicability of the *eta* Method was calculated based on *eta*'s two elements; LV interconnection and voltage optimisation. This was further scaled as assessment of potential sites indicated *eta* was practical on 3 out of 4 feeders at a distribution substation (ie 75%). The *eta* Method will be trialled on 160 LV circuits supplied via 5 Primary substations, around 10 HV circuits and 40 distribution substations which is less than 0.5% of our assets but represents a cross-section of eligible circuits. TNEI's review of *eta* identified that using the categorisation of LV circuits in the Transform model then 64% of Electricity North West's LV circuits are eligible for the *eta* Method; and **72% of GB LV circuits are eligible**.

To scale from *eta* to Electricity North West and to GB is by application of a multiplier of 326 and 13.28 respectively. These factors will be refined during the delivery of the *eta* Project.

### How a roll out of the Method across GB will deliver carbon benefits more quickly

Traditional reinforcement involves the construction of carbon intensive assets, particularly new underground cable or overhead lines and transformers. Significant time is currently required in the scoping, design, approval, construction and commissioning of reinforcement schemes. This is increasingly likely to become a bottle-neck, as electricity demand and generation is expected to grow. In contrast, the *eta* Method is a **quick-win** which provides a DNO with a series of intervention techniques to address the challenges of clusters of new demand and/or generation LCTs. The analysis of the Dunton Green network suggested that additional capacity and voltage headroom and legroom can be released for use in 9 or 5 weeks simply by installation of an interconnection point and new voltage regulation equipment as required, compared with a traditional reinforcement timescale for 36 or 17 weeks, for demand and generation led reinforcements respectively. This **quicker delivery of capacity** will prevent delays in the connection of low carbon generation and demand to the network, and positively impact customers' carbon emissions.

### Quantifying the potential carbon contribution of a roll out of *eta* across GB

Tyndall Manchester for Climate Change Research assessed the carbon impact of the *eta* Project, for an Electricity North West roll-out and a GB roll-out using the TNEI modelling results. If *eta* is deployed across the Electricity North West network this could save between 200 000 and 530 000 tCO<sub>2</sub>e, or at GB scale between 2.7 and 7 million tCO<sub>2</sub>e of asset carbon, contingent on the driver for change ie demand or generation led reinforcements. Over time the reduced losses associated with traditional reinforcement, in the case of demand led reinforcements, can see the benefits of lower *eta* assets outweighed depending upon the uptake of Low Carbon Technologies (LCTs). Net carbon benefits might therefore be as high as 2 million tCO<sub>2</sub>e for Electricity North West and 30 million tCO<sub>2</sub>e at GB scale over the 25 year period of calculation, or as low as -1.4 million for Electricity North West or -18 million tCO<sub>2</sub>e for GB, although this latter case is highly unlikely.

## Low Carbon Networks Fund Full Submission Pro-forma Evaluation Criteria continued

### **eta has the potential to deliver net financial benefits to existing and/or future customers**

The *eta* Method can be applied in stages therefore its application has been studied using generation led reinforcement (growth of PV's) and demand led reinforcement (growth of HPs and EVs). Analysis has been undertaken to assess *eta* across different growth time frames of 1 year, 10 years and 25 years to achieve a fixed percentage of LCT on the network. There are three key elements to the comparison of *eta* and traditional reinforcement: capital expenditure, operational losses and Conservation Voltage Reduction (CVR) benefits. Under a clustered growth rate of 1 year all the capital expenditure occurs in the first year. For *eta* there are increased benefits beyond the first year. In the Dunton Green case, losses compared to traditional reinforcement methods both increase and decrease. In the case of generation led reinforcement losses reduce more than traditional reinforcement; conversely for demand led reinforcement losses increase diminishing the savings of *eta* to be equivalent to the cumulative cost of traditional reinforcement over 25 years. But *eta* has additional benefit of providing energy efficiencies to the customer through CVR.

### **Method cost and Base Case costs at the scale of the Project**

*eta Method Costs:* The application of *eta* on the 160 Trial LV circuits, assuming 50% are generation led reinforcements and 50% demand led reinforcements occurring in one year, releases the same 9.16MW of network capacity as traditional techniques (see Appendix G for further information). The three components of the *eta* Method are:

- retrofit vacuum technology for LV fuse ways and the link boxes, including interconnection points;
- LV capacitors and/ or on-load tap changing transformers; and
- LV Network Management and Optimisation upgrades to Network Management System.

The WEEZAP and LNYX switches represent the main costs of the *eta* Method and enable a DNO to control and safely operate interconnected LV networks. The total cost for installing interconnection points and this equipment is [REDACTED] assuming a saving of 25% against the Trial costs as *eta* proves the value of the devices, and the Policy and safety documentation will allow other DNOs to implement. The voltage regulation equipment would cost £1.46 million, assuming a saving of 20% due to increased demand. For *eta*, Electricity North West proposes utilising its existing Network Management System (NMS) with some functionality amendments to include the Trial networks within the system. This approach minimised costs and is a possible enduring solution, so the development costs could be reduced to £450k to make the amendments and represent the networks within others' NMS. The Optimisation software product is an off-the-shelf product and was configured for *eta* at a cost of [REDACTED]. Future applications would benefit from *eta* and so replication would cost around 35% less at [REDACTED]. **Assumptions for future cost savings are included in Appendix G2 Method and Base Case calculations.** On the scale of the Project with the techniques proven gives a total cost of £5.49 million. This equates to an average £464/kW for the *eta* Method. This analysis considers only asset costs and excludes the additional annual savings and costs studied in the Project Business Case (Section 3).

*Base Case Costs:* TNEI's modelling of Dunton Green of the interventions for the reinforcement of the 160 Trial LV circuits using traditional methods would release network capacity of 9.16MW at a cost of £6.23 million, through cable overlays and J-loops. This equates to £929/kW for generation led reinforcement and £434/kW for demand led reinforcement. See Appendix G for information on Base Case and Method calculations.

*Summary of benefits analysis:* In all cases, **the *eta* Method costs less than traditional reinforcement.** Assuming the cluster growth is rapid (ie occurs in year one) with 50% of the LV circuits generation led reinforcements and 50% demand led reinforcements then the



## Low Carbon Networks Fund Full Submission Pro-forma Evaluation Criteria continued

NPV for the *eta* Project is £732k (ie £6.23 million less £5.49 million).

### The potential for replication across GB

The *eta* Method releases capacity up to 4 times faster and 40% cheaper than traditional reinforcement techniques for LCT clusters. Using the scaling factors, proposed by TNEI the *eta* Method will deliver 2 985MW and 39 630MW for Electricity North West and GB respectively.

### (b) Provides value for money for distribution customers

The *eta* Method delivers benefits across each of the Customer Service elements identified in Figure 4.1 below with **all the benefits accruing wholly to distribution customers**.

Figure 4.1 Our Stakeholder Priorities



The *eta* Trial will provide evidence that installing a combination of newly developed and off-the-shelf technologies will enable DNOs to, for the first time, obtain visibility and orchestrated real time dynamic control of their HV and LV networks; allowing efficiency improvements to be realised for the benefits of customers and increasing the reliability, sustainability and affordability of distribution networks. Preliminary studies by TNEI show that *eta* is applicable to approximately 72% of the GB network.

### Customer benefits

*eta* improves **affordability** now and in the future by providing immediate and recurring cost benefits to customers through **Conservation Voltage Reduction** techniques. This technique results in lower customer electricity bills by increasing the efficiency of customers' appliances. Initial studies by TNEI indicate that on the Dunton Green substation customers would share up to £3,400 from CVR (at the energy cost of 13p/kWh). This recurring saving will be important to all customers and will bring extra relief to households classified in the **fuel poverty** bracket. *eta* will, in addition, deliver longer term savings by deferring, and in many cases preventing, the traditional reinforcement costs that would otherwise have been necessary. These savings are passed on to customers in lower distribution use of system charges. *eta* facilitates the rapid connection of LCTs by releasing capacity and voltage headroom on existing circuits. The management of the voltage profile along the LV circuits allows customers' PV installations to deliver the maximum FiT income using the existing local network assets. If the *eta* Method is adopted by all GB DNO's the total anticipated saving to customers could be as high as **£8.6 billion**.

### Driving value for money

We are committed to maximising the value for money obtained from *eta* and have throughout the bid development used an **open and competitive procurement process**; this will continue through the Project life. Our aim is to ensure equipment and services are sourced in a fair and transparent manner in order to drive the best product and service solutions at the best price. During the **bid development phase** of *eta*, Electricity North West published an Expression of Interest on the Energy Networks Association's Low Carbon

## Low Carbon Networks Fund Full Submission Pro-forma Evaluation Criteria continued

Networks Fund Portal in order to offer external providers the opportunity to collaborate on the Project. Each response was evaluated and potential partners/ suppliers given feedback on their proposals. In addition, two Request for Information notices were issued; one for the supply of capacitors and the other for Optimisation software technology.

Other Project Partners have also been selected through a competitive process with the exception of Kelvatek who have been collaborating with Electricity North West on a series of IFI and First Tier LCN Fund projects to develop the WEEZAP. The WEEZAP device, and its companion product the LYNX, have been developed specifically to meet the challenges of operating LV networks with high levels of LCTs and are **key enabling technologies** in *eta*; they are the most advanced LV network control devices available in the world.

The competitive approach to purchasing products and services will be maintained throughout the technology build phase by using Electricity North West's Framework Agreements eg for link boxes and cable. These commodity items have previously been subject to a rigorous procurement process. Where no Framework Agreement exists for the necessary equipment or associated installation activities, a thorough competitive tender process will be completed. The time required to undertake these procurement activities has been built into the Project Plan.

### Innovation Funding Support

The majority of LV networks are operated in a radial configuration; *eta* will demonstrate how to transform radial networks into safe and reliable interconnected networks delivering **sustainability** and **reliability** benefits for our customers. *eta* co-ordinates existing voltage regulation and control equipment in a novel way and combines with **innovative LV control technology** to release capacity on the LV network, improve system reliability, decrease losses and operational costs and gain a better return on asset investment. These benefits are accomplished with no compromise to the high quality of supply that customers enjoy today.

A review of utilities in the UK and internationally has been undertaken to provide some context when considering the technology and **pioneering operational practices** proposed. Dynamic operation of LV circuits as an interconnected network, managed in real time both with automation and under the remit and authorisation of the Control Engineer has not been demonstrated elsewhere. Low Carbon Networks funding for this project is required to prove the *eta* Method applied at scale will deliver the expected benefits, the value of those benefits under different scenarios and how the *eta* Solution can be adopted by GB DNOs to provide value for money for all distribution customers.

Electricity North West will demonstrate, within a research & development project environment, limiting the technical and operational risks to an acceptable level, how *eta* can **deliver a fundamental change in approach to the management of LV networks**. Innovation funding enables significant changes to the systems and processes which would not have otherwise been contemplated. The Network Management System will be upgraded to manage LV network supply restoration automation and the control engineer's operational authorisation will be extended to the LV network.

Table 4.1 details the number of person days and day rates of labour for Electricity North West and each Project Partner.

Table 4.1 Project Resource

	ENWL	Kelvatek	Siemens	Impact	Universities
No. of Days	4 614	46	1 320	65	2 748
Day Rates (Average)	■	■	■	■	■

## Low Carbon Networks Fund Full Submission Pro-forma Evaluation Criteria continued

### (c) Generates knowledge that can be shared amongst all DNOs

By exploring **new network management and voltage methodologies** across a range of rural, urban and dense urban circuits and deploying newly developed or modified technology (as yet unproven on a GB distribution network), *eta* generates new knowledge relating to the Hypotheses and will deliver the following incremental learning for the industry:

**Specifications and Installation Methodologies:** Ready to use specifications enabling a DNO to purchase and install the retrofit devices required to enable application of *eta* will be produced. Installation requirements (including any local planning considerations) and results of monitored LV circuits to view the effect of low carbon technologies on the network will be made available.

**Transformation of Radial Networks into Interconnected Networks:** How to cost effectively transform radial LV feeders into an interconnected network. System operating procedures, impact of interconnection and protection considerations of deploying the enabling technology will be shared. The benefits of LV interconnection as the first intervention and the business case for interconnecting traditional HV and LV radial feeders. What numbers and types of LCTs will *eta* support and the affect that clustering of different types of LCTs will have on it.

**Real Time Control and Automation of LV Networks:** Planning, design and operation standards for real-time control of LV networks. The benefits gained from centralising control and improving network operating fault costs. Develop health and safety documentation and operational training guides;

**Network Management System and Interface:** How to configure and interface the Optimisation software with the NMS through a standard ICCC link.

**Network Configuration and Voltage Optimisation:** How to achieve optimisation of voltage profiles across the HV and LV circuits through use of voltage controllers, on-load tap changing distribution transformers and/or capacitors. Define settings, configuration parameters and operating procedures for each piece of network equipment and the appropriate software algorithms.

**Cost Benefit Analysis:** Economic analysis and carbon impact of the *eta* Method including quantification of the various benefits (eg losses reduction, energy reduction and investment deferral, carbon impact etc). Evaluate the extent and value of the losses reduction on networks and evaluate the extent and value of the reduction in customers' energy consumption from application of Conservation Voltage Reduction.

**Customer Engagement:** Customer engagement methodology and Customer survey results. Indicates how customers understand the initiative and provides evidence of whether or not they perceive any effects on their supply.

The knowledge obtained from applying the *eta* Method shall be made available to all interested stakeholders. Learning will be gained from the early stages of the Project and will continue throughout its lifecycle. It is important that the dissemination is made available in a timely manner and when new observations occur. Knowledge outputs will also include how *eta* supports the government's future ambitions for a low carbon economy. Identification of the most cost effective buy order of individual or combined solutions for a variety of LV circuit types and describe in what combination the new technologies should be applied.

### (d) Involvement of other partners and external funding

The *eta* Project has a strong consortium of Partners with proven delivery credentials. They are committed to proving at scale that the *eta* concepts and techniques can be employed to provide a real benefit in enabling the UK to transition to a low carbon economy. The partners

## Low Carbon Networks Fund Full Submission Pro-forma Evaluation Criteria continued

were selected from response to either the Expression of Interest process or by selective invitation to provide a response to the technology requirements specification. Partners were selected based on the following three criteria:

1. Prior experience in scope of work and reliability to deliver;
2. Involvement represents value for money for *eta*; and their
3. Commitment to Electricity North West, *eta*, its success and the dissemination of the learning gained.

*eta*'s partners are experts in their fields, be it in research, technology or customer engagement. Below is a list of our partners with a summary of both the scope of work they will undertake in *eta* and how their prior experience supports this.

**Kelvatek:** Kelvatek has a long history of LV Switching and Fault Management, with expertise in Vacuum Circuit Breaker (VCB) technology, automation and reclosing for LV networks, as well as designing and commissioning complete automation systems for major power projects such as Network Rail's Crossrail and West Coast Mainline signalling networks.

Well known Kelvatek products are the BIDOYNG Smart Fuse and REZAP Fault Master. Kelvatek has developed a retrofit LV vacuum circuit breaker with associated control, protection and monitoring electronics, called the WEEZAP, specifically for the *eta* Project.

*Prior Experience brought to the Project:* Kelvatek's extensive knowledge and experience in developing innovative network switching and monitoring equipment for LV networks is world leading, which in itself is outstanding given that it is an SME.

*Role on Project:* Kelvatek will supply the WEEZAP and the LYNX and associated adaptive protection software to *eta* to facilitate the management of the LV network, a first for a UK DNO. They will also support the Learning & Dissemination activities of *eta* and make available the WEEZAP and LYNX for the transfer of the *eta* concepts across the UK DNOs.

**TNEI:** TNEI is highly experienced in the design and analysis of all aspects of power generation, transmission and distribution. TNEI licences the modelling software that every GB DNO uses to design their distribution networks.

*Prior Experience brought to the Project:* TNEI works extensively with Electricity North West as well as other UK distribution network operators supporting normal business activities and Future Network Projects.

*Role on Project:* TNEI has a number of advisory and support roles within *eta*. The organisation will peer review the network design methodology, selection of *eta* Trial networks and provide technical support throughout *eta*. TNEI will be a key learning and dissemination partner for *eta*.

**Siemens:** Siemens is one of the world's leading technology vendors of power generation and energy delivery technologies.

*Prior Experience brought to the Project:* Siemens is a global technology vendor with extensive experience in successfully providing and implementing smart solutions into DNOs. The organisation offers a portfolio of services and products across the Smart Grid ecosystem, and is able to draw from the experience and knowledge that has been acquired in the delivery of such solutions on a global basis.

*Role on Project:* Siemens will supply, install and configure the substation Voltage Controllers at the Primary substations and supply, configure and commission the Optimisation software. Additional support will be provided to ensure that implementation of both the software and hardware will successfully interface with the existing systems and that all the necessary testing occurs. The successful supply and installation of the aforementioned will enable Electricity North West to Trial the *eta* optimisation techniques.

## Low Carbon Networks Fund Full Submission Pro-forma Evaluation Criteria continued

As a key learning and dissemination partner, Siemens will write an Optimisation Implementation Strategy setting out how DNOs with alternative NMS solutions can apply the Method and will provide additional support at learning events to further aid ease of roll out. Siemens is funding the provision of The Crystal as a venue for *eta* knowledge sharing events.

**Impact Research:** Impact Research is a leading marketing and customer engagement organisation within the UK.

*Prior Experience brought to the Project:* Impact Research has extensive experience in customer engagement activities within the utilities industry. The organisation has successfully delivered a number of projects funded by the LCN Fund.

*Role on Project:* Impact Research will support the *eta* customer engagement programme by co-ordinating the customer interactions during the Project to prove/disprove that customers within the *eta* Trial areas will not perceive any changes in their electricity supply (Hypothesis 2).

**The University of Manchester:** The University of Manchester is regarded as one of the leading universities in the world for Electrical Engineering in both its academic curriculum and research.

*Prior Experience brought to the Project:* The University's Electrical Energy and Power Systems Group has deep knowledge and experience in network modelling, power system dynamics and electrical asset health profiling. The well-respected Tyndall Manchester for Climate Change Research (at The University of Manchester) will support the carbon impact assessment work within the *eta* Project. Tyndall Manchester brings together the leading scientists, academics, economists, and engineers to develop sustainable responses to climate change for the GB economy.

*Role on Project:* The University of Manchester and the Tyndall Manchester will undertake jointly the following studies as part of *eta*:

1. *Cost benefit analysis:* This study looks into the cost benefit analysis and business case of the *eta* Method providing the analysis to prove/ disprove Hypotheses 4 and 5. The key outcome will be a report that details the economic justification for the application of the *eta* Method and the expected benefits for stakeholders compared against traditional techniques for connecting LCTs.
2. *Carbon impact assessment:* Examining the savings from reductions in energy consumption, changes in losses and the emissions implicit in assets. The key outcome will be a breakdown of the emissions impact of the *eta* Method identifying key areas of savings (eg line losses versus CVR) and an understanding of how these may scale across Electricity North West and GB in future.

**Queen's University, Belfast:** Queen's University has an enviable reputation for the teaching and research in the field of Electrical Engineering.

*Prior Experience brought to the Project:* The Energy, Power and Intelligent Control Research Cluster at Queen's University has extensive knowledge in distribution network modelling & operation, integration of LCTs, power system monitoring and application of optimisation techniques.

*Role on Project:* The University of Manchester and Queen's University will undertake jointly the following studies as part of *eta*:

1. *HV and LV Voltage and Configuration Optimisation.* This study validates the configuration and voltage optimisation methodologies for the HV and LV networks as applied in the *eta* Trials. The key outcome of this study is a report on the optimisation approaches and the extent that each approach facilitates the connection of new LCTs

## Low Carbon Networks Fund Full Submission Pro-forma Evaluation Criteria continued

to prove the *eta* Method can be used as the first intervention described in Hypotheses 1 and 6.

2. **Retrofit Design and Operation of LV Interconnected Networks:** This study is to produce practical rules to determine the most suitable location of voltage control equipment and joints to form interconnected configurations (ie the design policy); and to produce practical rules for the operation taking into account the characteristics of the interconnected feeders, different penetrations of LCT, and coordination with voltage regulation devices (ie the operation policy). The key outputs from this study are the results showing the evidence to prove/disprove Hypothesis 7 (time control of a portfolio of LV network solutions, using retrofit technologies with application combined or in isolation) and Hypothesis 3 (*eta* will have no effect on customers' internal installation or appliances).

These two studies will use the monitoring data gathered within the Trial and the three academic partners, the University of Manchester, the Tyndall Manchester for Climate Change Research and Queen's University, Belfast will be key learning and dissemination partners for *eta*.

### **(e) Relevance and timing**

Just like our previous Second Tier Projects C<sub>2</sub>C and CLASS the core principle of *eta* is to manage the existing assets in a smarter way to help resolve the future challenges driven by the transition to the low carbon economy. *eta* looks at using what there is now and through small enhancements aims to manage them in a smarter way and shape how the future distribution system is operated.

The "why now" question is easily answered as we have completed the preliminary work, under IFI and First Tier LCN Fund, and the technologies are looking promising; now we need to prove that these novel techniques work together and at scale. *eta* needs to be trialled, with the support of LCN Funds, so the business case can be established for normal business deployment and in good time before any GB wide roll-out.

#### **Smarter use of existing assets**

Around eighty percent of our existing network assets, particularly circuits, will exist in 2050 by which time a very significant volume of LCTs will have been connected to DNOs' networks. To minimise the cost of providing the required additional capacity our Project Business Case analysis shows that it is essential that the capabilities of existing assets be maximised before new investments are made. *eta* maximises the volume of LCT demand and generation that can be connected to existing circuits whilst simultaneously delivering reductions in network losses and improving the efficiency of customers' electrical appliances.

The *eta* Solution provides a first, and in many cases a final, intervention technique which will help the UK efficiently attain its carbon reduction plans.

#### **Future business planning & Price Controls**

The *eta* Solution provides a credible technique for a DNO to provide immediate and long lasting improvements to customers' energy efficiency. The learning gained in *eta* will shape our approach to RIIIO-ED2 as the escalation in LCT demand and generation connections increases significantly. *eta* outcomes should also help Ofgem consider how to oblige and/ or incentivise Suppliers and Network Operators to help reduce customers' energy bills.

#### **Knowledge and Learning**

*eta* complements and builds upon the learning gained from CLASS as it furthers the UK electricity supply industry's knowledge of a distribution network's voltage demand relationship and of Conservation Voltage Reduction techniques. In addition, *eta* provides the

## Low Carbon Networks Fund

### Full Submission Pro-forma

### Section 5: Knowledge dissemination

*This section should be between 3 and 5 pages.*

- Please cross the box if the Network Licensee does not intend to conform to the default IPR requirements.

*eta will generate substantial knowledge which will be shared equitably among all stakeholder groups.*

This section sets out a framework to deliver effective knowledge sharing and information dissemination.

The *eta* Trial will test if a DNO can increase the cost and carbon efficiency of the distribution network by changing its design and operation. *eta* aims to reduce the carbon impact of network operation and save energy costs for customers by adopting Conservation Voltage Reduction techniques on the LV network and installing further technology at both LV and HV to allow real time network sensing, control and management of HV and LV feeders and reconfiguration capabilities.

Knowledge sharing and dissemination activities will also seek to demonstrate the incremental learning gained from previous LCN Fund projects and explain how they became the foundations of *eta*.

#### Audiences

It is recognised that across our various stakeholder groups, the wide and varied knowledge gained in the *eta* project will have different benefits. It is important therefore to tailor knowledge sharing and information dissemination to meet the needs of each stakeholder group and give consideration to their individual requirements based on the issues which are of most interest to them.

The main audiences that have been identified are:

1. **Distribution Network Operators**, including IDNOs, the **regulator, DECC** and wider government will be keen to appreciate how the *eta* Method can be applied. This audience will focus on how *eta* can apply system management and data acquisition techniques to LV networks in city, town and country areas. *eta* will deliver the visibility and management of LV networks to support the transition to a low carbon economy whilst delaying or potentially avoiding the requirement for reinforcement investment, reducing costs for customers, improving quality of supply and network reliability. This will assist in decision making for future strategies and price control reviews. In addition, industry groups such as the ENA, SEDC, etc and UK and EU industry lobbyist groups will be interested with any potential impact on network design and operation and industry regulation.
2. Other **Energy Industry Participants** such as technology and LCT vendors, equipment manufacturers, retail **electricity Suppliers** and **generators**, will be interested in understanding the effect on their current business models and forecasts, identifying possible opportunities for product development and ascertaining any operational effects of the technique application.
3. **Academic Institutions** such as universities and higher education establishments will have a likely interest in using data generated throughout the *eta* Project in order to support their own programmes of research in this field. Knowledge dissemination with this stakeholder group presents a unique opportunity to invite alternative conclusions.
4. **Customers and consumer groups**, including charities focussed on eradicating fuel poverty, will form an important audience for our dissemination programme. Applying Conservation Voltage Reduction techniques will result in directly lowering customers' bills, from lower consumption. In addition it also supports the sustainability agenda by lowering the carbon footprint of customer activities.

## Low Carbon Networks Fund Full Submission Pro-forma Knowledge dissemination continued

5. **Internal** Electricity North West **stakeholders groups** will be interested in understanding the *eta* Project. These groups include members of the **Executive Leadership Team**, who will wish to understand how *eta* will affect and inform future price control reviews and also **Operational Personnel** who will need to learn new operational practices and achieve LV authorisation requirements to practise safe application of the *eta* Method. Learning will be widely shared throughout the organisation in order to promote the Project and evaluate how best to implement as business as usual in the future.
6. Local groups such as **Community Groups, Local Authorities** and **Registered Social Landlords** may wish to be involved in the Project to ensure that any impact is a positive one and also make use of the opportunity to become earlier adopters of LCTs as networks increase capacity.

### Dissemination Approach

Building upon experience gained through the delivery of C<sub>2</sub>C and CLASS, there will be a designated Knowledge and Dissemination Workstream and the Workstream Lead will promote dissemination activities in collaboration with Project Partners. This partnership approach allows access to a broader range of resources, delivering the programme cost effectively and ensuring that observations directly related to the Hypotheses and any additional experiences around the periphery of project delivery will be documented and shared.

Stakeholder groups have differing levels of expertise and diverse interests and will require knowledge and dissemination activities that are matched to their own motivations. This will be achieved through employing a variety of communication mediums; our guiding principles for this are to keep it simple, targeted and pragmatic.

We will derive maximum benefit from this Workstream by exploiting communication channels which support direct feedback from our audiences. Such two way information flows enable project responsiveness and bring opportunities for further incremental learning.

### Dissemination Methods

**Multiple forms of Web Based Dissemination** will access the widest reach of audiences. An *eta* microsite (linked to Electricity North West's website and referred to as the *eta* website) will be created and supplemented online by Social Media activity. This could include the establishment of *eta* community groups on sites such as LinkedIn and Twitter and using the knowledge transfer platforms of technology innovation organisations. Our web-based dissemination will make use of flexible, convenient and where appropriate interactive techniques in order to maximise retention of key learning outcomes. All forms of online presence will be dynamic enabling participation and two way communication. The *eta* website will contain a document library and potentially an active blog. Video podcasts of knowledge sharing events will be published on the *eta* and other sharing websites such as the IET.TV and YouTube.

**Lectures, Conferences and Workshops** will be designed to incorporate best practice from previous LCN Fund knowledge dissemination events and scheduled relative to project deliverables. This initiates the learning cycle at the point of the new knowledge emerging. A proportion of the workshops will be delivered through a traditional format to obtain valuable face-to-face time with key stakeholders and stimulate active participation of the audience. **This proportion of knowledge sharing events will be held at Siemens' flagship facility, The Crystal.** In some cases, the events may be filmed and made available as a video podcast. Webinars have been trialled by Electricity North West in the CLASS Project and as these have proven successful we will use this method again within *eta*.



## Low Carbon Networks Fund Full Submission Pro-forma Knowledge dissemination continued

**Academic Papers** published by our university research partners will be made available through their own dissemination routes and through the *eta* website.

**Learning installations** at appropriate venues, such as the Museum of Science and Industry in Manchester. We will evaluate whether the operational training could be delivered at our new training facility in Blackburn, due to open in autumn 2013.

**Press Releases** will be issued at regular intervals by an experienced in-house Press Officer. These articles will be designed to publicise *eta* activities and events and live project outcomes.

**Six Monthly Progress Reports** which are a mandatory requirement for Ofgem will also be published on the *eta* website giving interested parties an opportunity to evaluate progress of the project against the Project Plan.

**Internal knowledge dissemination** will be delivered by the *eta* Workstream Lead in conjunction with the Communications department. This will ensure that business as usual solutions for communications is utilised to make the dissemination effective. This may include, but not be restricted to, monthly team briefs, articles in the bi-monthly company magazine (Newswire), utilising the weekly email bulletin facility and issuing targeted "special interest" group emails. Making the *eta* Project's aims and objectives widely known and giving up to date information on lessons learned and progress will contribute to project delivery and lay the foundations for a successful roll out of the *eta* Method as Business as Usual post Trials.

**A Close Down Report** following completion of the Project will be made available to all. This will be a summary report in line with Ofgem requirements which encapsulates the key findings, and lessons learned.

To assist in the planning of knowledge dissemination events, stakeholder mapping against anticipated areas of interest is shown in Tables 5.1 and 5.2 overleaf.

### Continuous Improvement and Review of Dissemination Methods

Various methods to **evaluate the effectiveness** of dissemination activities and measure the outcomes will be employed to establish the audience perception of quality and value of communications or to measure the extent of attitude and/or behaviour change as a result of the communication efforts. These methods may include web analytics, polls, focus groups or surveys. Undertaking this activity will allow us to consider possible issues that may act as a barrier to dissemination activities.

## Low Carbon Networks Fund

### Full Submission Pro-forma

#### Knowledge dissemination continued

 Table 5.1 *eta* Key Deliverables

Milestone	Deliverable	Responsible
Site selection report	Description of the site selection methodology and which networks were chosen and why	Electricity North West
Specifications, installation methodologies and operating regimes	Functional and technical specification documentation, and the installation methodologies and operating practices for the new equipment, including optimisation and control technologies on HV and LV substations and feeders	Electricity North West, Kelvatek, Siemens and Suppliers
Network management system interface and configuration	Functional specification documentation on the operational link between optimisation software and Electricity North West's Network Management System. <b>An Optimisation Implementation Strategy for adoption by DNOs utilising other NMS solutions</b>	Electricity North West and Siemens
LV network management documentation	Documentation for safe system of work on Trial LV networks, including new Engineering Policy Documents, Codes of Practice and authorisation protocols	Electricity North West
Network data	Full set of raw data within project database	Electricity North West, TNEI, UoM and QUB
Academic reports and Consultations	<ol style="list-style-type: none"> <li>HV and LV voltage and configuration optimisation</li> <li>Retrofit design and operation of interconnected LV networks</li> <li><i>eta</i> cost benefit assessment study</li> <li><i>eta</i> carbon impact assessment</li> <li>IET consultation on impact of <i>eta</i> on customers' electrical installations and appliances</li> </ol>	Electricity North West, Tyndall, UoM and QUB, IET
Customer <b>experience</b>	Customer <b>experience</b> report including <b>details of customer engagement and survey feedback from customers within the Trial locations</b>	Electricity North West and Impact Research
<i>eta</i> progress and close down reports	Six monthly progress reports Close down report	Electricity North West

## Low Carbon Networks Fund

### Full Submission Pro-forma

#### Knowledge dissemination continued

Table 5.2 *eta Audience and Dissemination Methods*

Audience	Dissemination Method	Milestone
Distribution Network Operators, including IDNOs	<i>eta</i> website, webinars, knowledge sharing events, consultation and advertorials	All key deliverables
Energy industry participants	<i>eta</i> website, webinars, knowledge sharing events, consultation and advertorials	Various depending on area of interest
Academic institutions	<i>eta</i> website, webinars, consultation and knowledge sharing events	Network data & academic reports
Government/regulator	<i>eta</i> website, webinars, knowledge sharing events, consultation and advertorials	Customer survey, carbon assessment, losses and energy reduction values
Local groups	<i>eta</i> website, publicity and advertorials	Site selection report, customer survey, carbon impact assessment, energy reduction values
Consumer groups	<i>eta</i> website, publicity, learning events	Customer survey, carbon assessment, energy reduction values
Electricity North West	Internal workshops, intranet, newsletters etc	All key deliverables
Other	All of the above depending on individual or group	Various depending on area of interest

# Low Carbon Networks Fund

## Full Submission Pro-forma

### Section 6: Project Readiness

*This section should be between 5 and 8 pages.*

Requested level of protection require against cost over-runs (%):	0%
Requested level of protection against Direct Benefits that they wish to apply for (%):	0%
<p><i>By deploying off-the-shelf technology in a novel way and using our experienced and committed Partners we have a high degree of confidence over delivery</i></p> <p>Electricity North West is confident that it can start <i>eta</i> in a timely manner due to our robust plans should the submission be successful. A significant amount of preparatory work has taken place prior to the Full Submission using knowledge gained from previous projects. These factors are discussed in more detail below but can be summarised as:</p> <ul style="list-style-type: none"> <li>• Forerunner IFI &amp; First Tier LCN Fund Projects;</li> <li>• International Review of Concepts;</li> <li>• Partnership, Consortium &amp; Contractual Arrangements;</li> <li>• Project Costs and Direct Benefits;</li> <li>• Programme Management and Governance;</li> <li>• Project Plan;</li> <li>• Risks and Mitigation;</li> <li>• Re-use of existing LCN Funded project infrastructure; and</li> <li>• Customer Engagement.</li> </ul> <p><b>Forerunner IFI &amp; First Tier LCN Fund Projects</b></p> <p>Early understanding of the two key <i>eta</i> concepts were borne out of the previous years' Second Tier LCN Fund Projects C<sub>2</sub>C and CLASS. However the required equipment and technology was developed within or deployed in trials undertaken under a range of Innovation Funding Incentive (IFI) and First Tier LCN Fund Projects. Undertaking the First Tier LCN Fund projects of LV Network Solutions<sup>8</sup>, Voltage Management at LV Busbars<sup>9</sup> and LoVIA<sup>10</sup> projects have provided early learning on the installation, use and remote control of on-load tap changing distribution transformers and capacitors in LV networks; whilst undertaking the IFI project, Conservation Voltage Reduction, developed our approach to connecting HV capacitors to HV circuits and to understand how to control them to vary the voltage profile of the circuit. A further IFI project, called LV Vacuum Circuit Breaker resulted in the joint development, with Kelvatek, of the WEEZAP. <i>eta</i> deploys these individual technologies in combination and at scale across a range of different network types to take the next incremental learning step.</p> <p><b>International Review of Concepts</b></p> <p>Electricity North West has undertaken benchmarking and fact-finding visits to the USA, Australia and continental Europe in preparation for the future replacement of our Network Management System in the next price control period. For this proposal TNEI, our technical support partner undertook a paper review to study the concepts of interconnection in LV networks and voltage control, using capacitors. Their report highlighted the use of capacitors for both losses reduction and voltage optimisation, although these were independent schemes in different countries and none in the UK. The capacitors were, particularly in the case of the losses reduction, permanently connected to the network and energised. Electricity North West aims to take this a stage further by employing both</p>	

# Low Carbon Networks Fund Full Submission Pro-forma Project Readiness continued

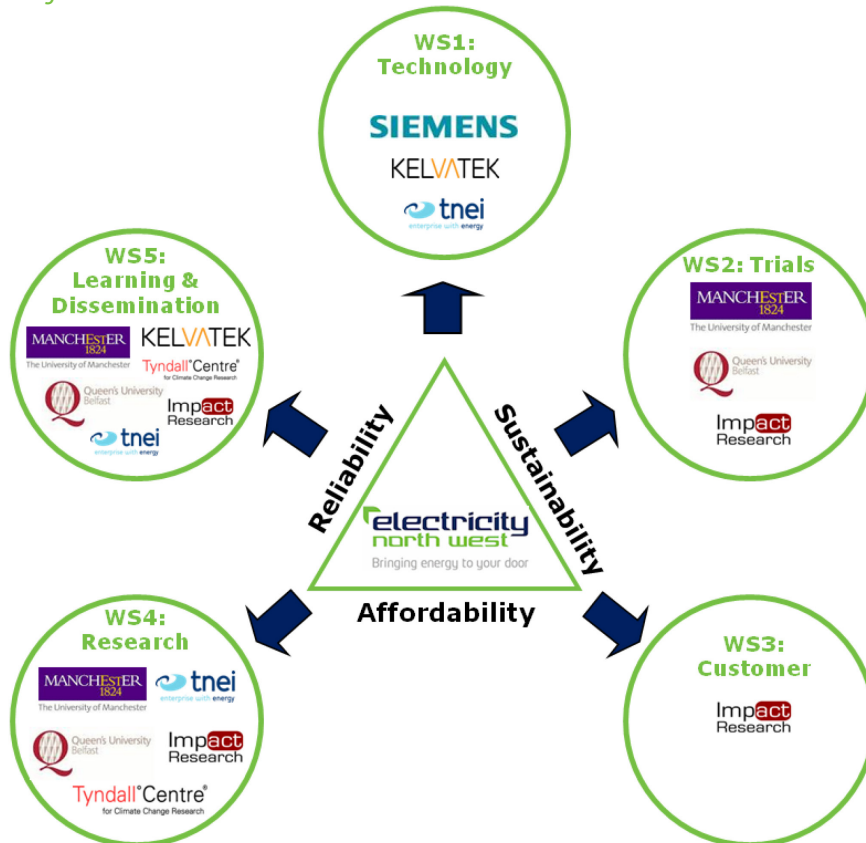
techniques simultaneously and through the use of off-the-shelf Optimisation software will switch the capacitors in only at the optimum time to deliver the greatest benefits.

The concept of interconnected LV networks is not unusual in the UK but these networks were designed and operated as such and had limitations due to the use of fuses as protection. Electricity North West proposes to convert existing radial LV networks into interconnected LV networks and through the use of new technologies, such as the WEEZAP and the LYNX, will have greater protection and control functionality.

### Partnership, Consortium & Contractual Arrangements

One of the key criteria for building a robust *eta* Project was the selection of the Project Partners, and the formation of a strong dedicated consortium; Figure 6.1 shows the partners involvement in the *eta* workstreams. Identification of our preferred Partners was undertaken after managing a series of Expressions of Interest (EOI) and Requests for Information (RFI) in spring 2013. We issued an EOI in March 2013, using the ENA LCN Fund Portal, to seek potential partners or suppliers for the specialist skills and understand their associated costs and contributions. In April and May 2013 we held two RFIs to seek potential partners or suppliers and their costs and contributions for the technology elements for *eta*. This approach was trialled this year to promote wider awareness and involvement in our LCN Fund Projects and generate keener costs for the proposal through competition with the aim of delivering value for money for the *eta* Project, ultimately funded by customers. The selection of Project Partners and suppliers is dependent on experience, skills, cost and the organisation's ability to commit resources to deliver both the *eta* Project and a transferable solution to other GB DNOs. The decision on which Project Partners are selected is taken by Electricity North West's Future Networks Steering Group.

Figure 6.1 Project Partner involvement within *eta* Workstreams



## Low Carbon Networks Fund Full Submission Pro-forma Project Readiness continued

As part of the proposal, the work schedules that have been developed together with our Partners ensure that *eta* is in a unique position to add the agreed work schedules to existing contractual arrangements. Electricity North West has confirmed Partners' and suppliers roles and responsibilities regarding the Project Plan (See Appendix F), financial costing, contributions and the provision of services and/ or products. A key outcome of this is that Electricity North West's approach minimises time spent on agreeing contractual agreements and ensures that the Project is ready to go once funding has been granted.

Where a technology element is a commodity (ie cable and capacitors) we will run competitive tenders or use existing Framework Agreements for the procurement of these items.

### Project Costs and Direct Benefits

The *eta* Project costs have been calculated using input from Framework Agreements, Requests for Information, the Project Partners and our internal finance personnel. Where applicable the resource costs have been disaggregated on a day rate basis and scaled over the period of the *eta* Project using the RPI forecast that Ofgem defined. The uncertainty regarding the costs and installation of the new technology has been de-risked from the knowledge gained during the sample network designs undertaken by TNEI, Parson Brinckerhoff and Electricity North West.

Within the overall cost calculation, we have added an additional 8.85% as contingency against any potential changes to costs as the Project continues. Where costs to deliver *eta* are uncertain we have labelled them as contingency cost elements. For example:

- As we will undertake actual Trial site selection, using the defined site selection methodology, in the *eta* Project we are unsure whether we will be able to re-use infrastructure created in previous IFI or LCN Fund projects and so we have identified these technology elements as contingency costs eg Voltage Controllers at Primary Substations.

Benefits and costs have been put through Electricity North West's internal investment appraisal process and approved.

A Management Accountant will be embedded in the *eta* Project team to manage the budget. He/she will be responsible for managing all costs and constructing and delivering the reporting requirements as part of the *eta* Project. Electricity North West will run a robust financial tracking and reporting system in line with its current internal policies and frameworks. As per the LCN Fund Governance Document, the Project finances will be held in a separate Project Bank Account which will meet the following requirements:

- Show all transactions relating to (and only to) the *eta* Project;
- Be capable of supplying a real time statement (of transactions and current balance) at any time;
- Accrue expenditures when a payment is authorised (and subsequently reconciled with the actual bank account);
- Accrue payments from the moment the receipt is advised to the bank (and then subsequently reconciled with the actual bank account);
- Calculate a daily total; and calculate interest on the daily total according to the rules applicable to the account within which the funds are actually held; and
- Electricity North West will engage with our auditors, Deloitte, to alert them of their potential responsibilities should *eta* be awarded the funding.

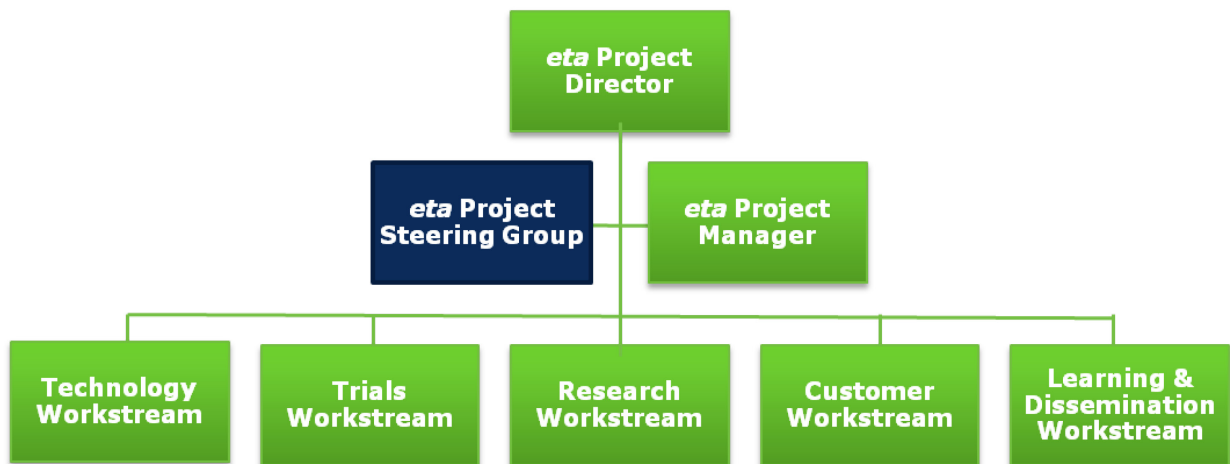
### Programme Management and Governance

The Programme Management and Governance approach currently employed for the successful delivery of the previously funded LCN C<sub>2</sub>C and CLASS Projects will be re-

## Low Carbon Networks Fund Full Submission Pro-forma Project Readiness continued

employed to manage the *eta* Project. This proven project governance methodology will ensure that *eta* meets and where possible exceeds the delivery criteria and milestones identified. Where enhancements to the methodology are identified in the delivery of the C<sub>2</sub>C and CLASS Projects these can be easily transferred into the *eta* Project as the delivery teams co-exist together, under three team managers in the Future Networks team within Electricity North West. Delivery success is being achieved by the bottom-up proven governance methodology and the top-down philosophy to be open, collaborative, and commitment to get it right first time. These will be embedded in the *eta* Project team. The project management structure is shown below in Figure 6.2.

Figure 6.2 High Level *eta* Project Management Structure



Ultimate Project direction will come from the Project Director, Mike Kay, Director for Networks Strategy & Technical Support at Electricity North West. Key decisions and sign off will however be managed by the *eta* Project Steering Group, consisting of representatives from Electricity North West and the various Project Partners. The *eta* Project Steering Group will sit above the Programme Management Office (PMO), and will have access to the day to day running of the Project enabling them to make key informed decisions as to the strategic direction of *eta*.

### Project Plan

The Project Plan sets out the approach that the Electricity North West Project Delivery team has determined to bring success. The Plan identifies five Workstreams in addition to the mobilisation and close down phases. The Plan is described below and shown diagrammatically in Figure 6.3, and a more detailed version is in Appendix F.

# Low Carbon Networks Fund

## Full Submission Pro-forma

### Project Readiness continued

Figure 6.3 High Level eta Project Plan

		2014	2015	2016	2017
Phase	Mobilisation of Project Management Office Project Governance	■	■	■	■
Phase 1	<b>Successful Delivery Reward Criteria</b>	*			
	Site selection and Network design	■			
	Draft specifications and manage equipment tenders	■			
WS1: Technical	<b>Successful Delivery Reward Criteria</b>		**		
	Installation of new HV & LV Network Equipment for eta	■	■		
	Configuration of existing Network Management System (NMS)	■	■		
	Design, Build, Install, Configure, Test Optimisation software	■	■		
WS2: Trial	<b>Successful Delivery Reward Criteria</b>		**		*
	Design Trial Regime		■	■	■
WS3: Customer Engagement	<b>Successful Delivery Reward Criteria</b>	* **	*		*
	Write Customer Engagement Plan and Privacy Statement	■	■		
	Design and create customer survey and focus group scope		■		
WS4: Research	<b>Successful Delivery Reward Criteria</b>			*	*
	Research, data analysis and modelling		■	■	■
WS5: Knowledge Dissemination	<b>Successful Delivery Reward Criteria</b>	* ***	* **	**	* **
	Website development	■	■	■	■
Phase II	<b>Successful Delivery Reward Criteria</b>				
	Decommission Equipment				■
	Close Down Report				■

1. **Mobilisation Phase:** The mobilisation of both internal and external teams, as well as the retention of those individuals across the Project delivery lifecycle is crucial to the successful start and continued delivery of *eta*. Within Electricity North West we have identified two full time dedicated resources to the delivery of *eta*, managed by a full time Electricity North West Project Manager. The team will also receive significant support from within the wider Future Networks, including the C<sub>2</sub>C and CLASS delivery teams. All the Partners have identified resources that will be dedicated to *eta*.
2. **Technology:** During the Technology Workstream, the *eta* Project Team will finalise the site selection, have it peer reviewed and will competitively tender the network equipment and installation. Electricity North West's Network Management System will be amended to accept the Trial LV networks and configured, through the development of an ICCP link, to the Optimisation software. Additional monitoring equipment will be deployed, where appropriate.
3. **Trials:** In the Trial Workstream the *eta* Trial Design will be created based on the OFF/ON arrangement and the Test Regimes defined earlier in Table 2.2, Section 2.3. This Design will be peer reviewed prior to the start of the Trial period.
4. **Customer Engagement and Survey:** The Customer Workstream runs in parallel with the Trials Workstream and involves the surveying of customers **and managing customer interactions throughout the *eta* Project.**
5. **Research:** The Research Workstream will be jointly led by The University of Manchester and Queen's University, Belfast who will carry out the research and analysis of data collected, to prove or disprove the defined Hypotheses and deliver the key *eta* learning. The Universities will publish reports drawing out conclusions, based on the cost benefit analysis, for a DNO to transform LV radial networks into interconnected LV networks using



## Low Carbon Networks Fund Full Submission Pro-forma Project Readiness continued

the dynamic voltage regulation techniques to resolve the aforementioned challenges.

6. *Learning & Dissemination*: The Learning & Dissemination Workstream will incorporate all knowledge dissemination activities and make use of a blend of real and virtual media channels to ensure maximum reach. Virtual media channels may include website, webinars, podcasts, social media, forums and blogs; whilst real channels include knowledge sharing events, advertorials and presenting our learning at seminars and conferences. These activities are defined in internal and external dissemination activities terms, via a number of tailored communication channels for the audiences *eta* has identified.
7. *Close Down Phase*: During this phase *eta* will be wound down, the new equipment will be decommissioned and the Close Down Report drafted, approved and published. In addition, we will update and publish Electricity North West's approach to managing LCT clusters.

The Project Plan mitigates the identified risks as far as possible and provides a clear roadmap to steer and to support the *eta* Project delivery team in achieving the relevant milestones on time and within budget.

### Risks and Mitigation

A key aspect of our Project management methodology is the capability to manage risks and issues. *eta* will adopt the successful Risk and Issues process currently in operation within Electricity North West, but modified from our experience in the delivery of LCN Funded projects. The Risk and Issues Model employed considers risks and issues that are business-as-normal and those specifically related to the *eta* Project all of which will be articulated in a common format.

The format and description of the Electricity North West scoring matrix is presented in Appendix E. The scoring matrix, which has been adapted from previous experience delivering C<sub>2</sub>C and CLASS, will be used by the Project Management team and Project Steering Committee to continually review *eta* risks, their mitigating action(s) and controls and to ensure that risks are managed in priority order. The risk model describes the Methodology for determining an 'uncontrolled' risk score. However, if control measures are applied, aimed at reducing the hazard and/or mitigating the risk, it should be possible to produce a controlled risk score that is lower than the uncontrolled risk.

Appendix E outlines the risks that have been identified prior to the start of *eta*. Within the risks model, likelihood and consequences will each be given a score from 1 to 5, and the resulting product of these two ratings used to score and rank the risks on *eta*. The model has been used across the business for many years and has been found to be both robust and recognised as an exemplar approach.

Also in place is a risk escalation process which documents how certain risk types are escalated up through the *eta* Project team. The governance processes to be operated across the Project Partners, will regularly review risks and issues and either remove these if agreed mitigation has occurred and/or bring new issues or risks to the attention of the *eta* Project Steering Group.

The Steering Group will identify the circumstances which may lead to the Project being suspended, until such time as sufficient risk mitigation has occurred to enable on-going management of the risk or issue; or to halt the Project and defer further commitment until agreement has been reached with Ofgem on how to proceed. Mitigation and contingency management will form a key part of the risk strategy. When a risk is raised the Project team will be responsible for creating a mitigation action that can be brought into play should the risk be realised.

## Low Carbon Networks Fund Full Submission Pro-forma Project Readiness continued

### Re-use of existing LCN funded project infrastructure

Wherever possible *eta* will re-use infrastructure that had been developed and funded by IFI and LCN Fund projects. For example, we will look to select the *eta* Trial networks where we have created closed rings under the C<sub>2</sub>C Project; fitted Voltage Controllers at Primary Substations under the CLASS Project; and fitted monitoring equipment under any of the First and Second Tier LCN Fund Projects. The knowledge gained in developing the interfaces, using either SOAP or ICCP protocols, funded in the C<sub>2</sub>C and CLASS Projects, has provided us confidence that we will be able to cost-effectively develop the communications interface between our Network Management System and the Optimisation software. This increases the value for money of *eta*, minimises the risks and facilitates the Project's readiness. In addition, *eta* will utilise the learning gained from CLASS on the voltage-demand relationship and relevant LCN Fund projects delivered by other DNOs, such as the LV Network Templates project.

### Customer Engagement

Throughout the bid preparation process Electricity North West has discussed customer engagement with our Project Partner, Impact Research, who will deliver the Customer engagement and survey. The knowledge gained from the development of the customer engagement for CLASS has helped us scope out a comprehensive approach to managing the customer relationship, from the initial customer awareness campaign through to gaining customer feedback on the *eta* Trials including the customer survey; a key aspect to ensure the customer experience in *eta* is a positive one.

In addition, we conferred with a number of electricity Suppliers during the development of *eta* to discuss our customer engagement proposals and no issues were identified.

## Low Carbon Networks Fund Full Submission Pro-forma

### Section 7: Regulatory issues

*This section should be between 1 and 3 pages.*

- Please cross the box if the Project may require any derogations, consents or changes to the regulatory arrangements.

#### **eta Project's Regulatory Impact**

We do not expect that the *eta* Project will require any derogation, licence consent or licence exemption for its delivery. *eta* trials active network management and voltage control in interconnected HV and LV networks to increase the utilisation and flexibility of the existing network assets to accommodate LCTs so *eta* could have profound implications on the design and operation of distribution networks. The *eta* Method will prove that network operators can optimise their distribution networks to have a positive effect on operational carbon through the reduction in losses, customers' energy consumption and the ability to quickly restore electricity supplies following an interruption.

*eta* will involve the installation of new HV and LV network and voltage control equipment and in some cases the installation will require a planned supply interruption. We have sought protection against expected planned supply interruption penalties.

#### **Long Term Regulatory Impact**

The learning from the Trial and test regimes will allow the *eta* Project team to consider updates to the planning, design and operation standards for distribution networks, particularly for LV networks, including feeding into the long term review of ENA ER P2/6 recently started by the Distribution Code Review Panel. The longer term impact on the regulatory regime applied to network operators is significant and positive with the following areas potentially seeing change:

- regime for load related capital expenditure, especially for the connection of LCTs;
- regulatory incentive mechanisms of Interruption Incentive Scheme (IIS) and Distributed Generation;
- Potential regulatory incentive mechanism on Conservation Voltage Reduction;
- common connection and use of system charging methodologies applied by distribution network operators;
- regime for the provision of connections;
- National Terms of Connection within Distribution Connection and Use of System Code (DCUSA); and
- Future DSO operational management.

## Low Carbon Networks Fund Full Submission Pro-forma

### Section 8: Customer impacts

*This section should be between 2 and 4 pages.*

*eta will maintain a positive customer experience throughout the Project duration*

Electricity North West is committed to building strong and long lasting relationships with customers and works hard to cater for everyone so they can enjoy a reliable and efficient electricity supply and the best customer service possible.

The *eta* Method will be trialled on 5 Primary substations and 40 related distribution substations located across three areas of Electricity North West's network involving around 45 000 customers. Impacts on these customers will vary and we will detail these impacts on the various customer groupings as part of the Customer Engagement Plan, a draft version is included as Appendix I.

Electricity North West will segment customers into the following groupings:

1. Customers in the Trial areas;
2. Customers on the Trial networks who will experience planned interruptions for the installation of the network equipment;
3. Customers on the Trial networks who may receive short duration interruptions.

#### General Publicity

Electricity North West will communicate with customers to publicise the *eta* Project in advance of technology installation to provide a basic understanding of the Project objectives and the importance of the low carbon agenda. Care will be taken to communicate with customers in such a way that there is no confusion with the smart meter roll out. This will be achieved via tailored communications which may be a combination of written, audio and visual mediums. When defining our customer communication approach we will be led by feedback from an Engaged Customer Panel. All *eta* activities will be conducted in a manner so as not to disrupt the smart meter programme.

#### Trial Networks - Supply Voltage

Application of the *eta* Method will involve flattening the voltage profile to deliver a consistent supply voltage to all customers wherever they are situated in relation to the substation. This will mean that some customers will receive lower voltages than they do currently. As appliances are designed and manufactured to operate across Europe where voltage is historically lower (220 volts), the application of lowering the voltage profile (ie Conservation Voltage Reduction) will have no adverse effect on appliance operation and is consistent with equipment specifications. Figure 8.1 is a stylized representation of the *eta* effect demonstrating that each customer within the Trial area will receive a supply voltage well within statutory limits.

*Figure 8.1 Voltage range*



A flattened voltage profile is achieved through the installation of capacitors across HV and LV circuits. These commodity items are currently used worldwide by network operators,

## Low Carbon Networks Fund Full Submission Pro-forma Customer impacts continued

most notably in USA & Australia, to manage voltage and also by Industrial and Commercial customers in the UK (and worldwide) to improve poor power factors. In preparation for the *eta* bid, consultants TNEI, PB Power and S&C Europe worked independently of each other to research the various uses of capacitor. These consultants were unable to find any reasons for not using capacitors to control voltage in the UK context and are all supportive of the technological approach in the *eta* Project.

### Trial Networks - Planned Supply Interruptions

The application of *eta* will require enabling technologies to be installed on the Trial networks. Following Trial network selection, each substation and circuit will be assessed to establish if the installation can be completed without the need for any planned supply interruption. We will consider whether it is possible to avoid supply interruptions by back feeding from an adjacent substation or attaching a generator for the duration of installation activities. There is a remote possibility that some Trial locations will not facilitate these options which will result in planned supply interruptions. It has been assessed that in the very unlikely event that this does occur then the maximum impact of these interruptions will be up to eight hours for the installation of voltage regulation equipment. If it becomes necessary to interrupt customer supplies, a shutdown will be arranged and customers will be notified in accordance with standard procedures. Vulnerable customers, identified from the Priority Service Register, will be notified by telephone in addition to the standard written notification, in keeping with normal practices.

We anticipate that a small number of planned supply interruptions are necessary for the installation of equipment at distribution substations where it is not possible to safely provide alternative supply to customers; the protection from incentive penalties is £29,560.

### Trial Networks - Unplanned Supply Interruptions

The change in operating arrangements for the selected circuits within *eta* could potentially increase the number of short duration interruptions experienced by customers. Interconnecting circuits will generally mean increasing the number of customers who will experience an individual fault event. However, the new operating regime should deliver a shorter interruption to supply than under the current operating arrangements. Unplanned supply interruptions during *eta* will allow us to prove the concept works and that the control management systems operate as expected. Around 240 customers per annum in the *eta* Trial LV networks will experience on average 58 minutes **less time** without supply from transient faults. We will inform customers about the theoretical increase in short duration interruptions.

Retrofitting the LV network with WEEZAPs should improve the speed of restoration for permanent faults for those customers on the *eta* Trial LV networks, as the WEEZAP's in-built fault location functionality will enable quicker location of the fault.

### Trial Participants - Customer Experience

*eta* will seek **feedback from** customers from within the Trial areas to **understand whether they** notice a change in their electricity supply during the Trial period; **this** is crucial to answer Hypothesis 2, "Customers within the *eta* Trial area will not perceive any changes in their electricity supply when the *eta* Method is applied".

The technique used to engage with customers has been carefully considered based **upon** previous experience from other LCN Fund Projects; **especially the CLASS Project where we will undertake quarterly customer surveys to understand the sensitivity of customers to changes in voltage. The level of voltage changes experienced by customers in the *eta* Trial will be very similar to that in the CLASS project. As such we intend to utilise the customer survey work already funded through CLASS and reduce the depth of the customer**

## Low Carbon Networks Fund Full Submission Pro-forma Customer impacts continued

engagement work in *eta*.

In *eta* we will inform customers on the Trial networks of the project through a general awareness campaign early in the project; and then a) quantify the customer experience by recording and managing any customer queries and b) qualify the customer experience by holding a focus group in each of the Trial areas in later part of the second year of the Trial period. This will ensure we have sufficient information to prove Hypothesis 2 whilst reducing costs by leveraging earlier Tier 2 work.

**Surveys:** Prior to performing any survey interviews, Electricity North West will issue a data privacy statement summarising the compliance strategy which will ensure that *eta* complies with the Data Protection Act 1988.

The results of these surveys and understanding customers' tolerance to any perceived change will establish the viability of the *eta* Method being applied at a GB level.

### Managing Customer Enquiries

Our aim is to maintain a positive customer experience throughout the duration of *eta*. This upholds the Electricity North West core values of putting our customers at the heart of our business. This commitment will be achieved by employing a number of communication channels so that customers will find it simple to raise any questions or concerns at a time convenient for them using the following channels:

**Telephone** – Electricity North West operates an enquiry service that is continuously staffed and can be contacted 24 hours a day and 7 days a week on 0800 19584141; or

**SMS** – For customer's preferring to receive a call back, they can send an SMS quoting "*eta*" to a dedicated number; or

***eta* website** – The *eta* website will contain all relevant customer focused information including Trial areas, customer pamphlets and project awareness literature and Project Team contact details. Frequently Asked Questions will be posted on the site and updated regularly. If the customer is unable to find an answer to their specific issue through this, a "Contact Us" function will allow them to submit their query and a representative of the Project Team will respond through the customer's preferred feedback method; or

**Written Correspondence** – The *eta* Project team can be contacted at the following address: *eta* Project Team, Frederick Road, Salford, M6 6QH.

## Low Carbon Networks Fund Full Submission Pro-forma

### Section 9: Successful Delivery Reward Criteria

*This section should be between 2 and 5 pages.*

#### Criteria (9.1)

##### Technology Workstream

1. Produce and apply the *eta* site selection methodology and select the *eta* Trial networks;
2. Complete procurement exercise for all *eta* network equipment;
3. Install and commission all network equipment;
4. Update NMS, develop interface and install and commission the Optimisation software;
5. Update LV network management policy protocols, including adaptive protection settings;
6. Produce briefing and training materials on new LV network management and operational procedures for internal dissemination.

#### Evidence (9.1)

##### Technology Workstream

1. Publish on the *eta* website a report detailing the site selection methodology, and a map of *eta* Trial areas by July 2014;
2. Contracts for the supply of networks equipment signed by July 2014;
3. Publish network equipment specifications and installation reports by September 2015;
4. Publish NMS, interface and Optimisation configuration and commissioning reports by September 2015;
5. Publish new LV network management protocols by June 2015;
6. ENWL operational personnel, including Control Engineers briefed and/ or trained on LV network management protocols by June 2015.

#### Criteria (9.2)

##### Trials Workstream

1. Complete Trial and Test Regimes design;
2. Commence live Trials;
3. Complete the suite of *eta* Trials and Tests;
4. Transfer Trial data to University of Manchester and Queen's University Belfast.

#### Evidence (9.2)

##### Trials Workstream

1. Publish the Trial and Test Regimes design report on *eta* website by October 2015;
2. Publicise commencement of live Trial on *eta* website by September 2015;
3. Publish on *eta* website a summary overview of each Trial; with summaries of all Trials and Tests available on the website by December 2017;
4. Confirmation received from University of Manchester and Queen's University Belfast confirming successful receipt of/completion of data transfer process by September 2015.

#### Criteria (9.3)

##### Customer Workstream

1. Develop Customer Engagement Plan and Data Privacy Statement;
2. Produce appropriate campaign materials to raise awareness about *eta*;
3. Test the Customer **campaign** materials using the Engaged Customer Panel;
4. Customer Contact Centre briefing and training materials created and delivered;
5. Produce report of Customer Surveys.

## Low Carbon Networks Fund Full Submission Pro-forma Successful Delivery Reward Criteria continued

### Evidence (9.3)

#### Customer Workstream

1. Send Customer Engagement Plan and Data Privacy Statement to Ofgem by June 2014;
2. Deliver general awareness materials and publish on the *eta* website by **October** 2014
3. Engaged Customer Panel workshop delivered by **September** 2014, lessons learned published on the *eta* website by **October** 2014;
4. Customer Contact Centre training delivered and materials published on the intranet by July 2015;
5. Publish on *eta* website **the** Customer Survey report by December 2017.

### Criteria (9.4)

#### Research Workstream

1. Deliver the HV and LV Voltage and Configuration Optimisation Study;
2. Deliver the Retrofit Design and Operation of Interconnected LV Networks Study;
3. Deliver the Cost Benefit Assessment Study;
4. Deliver the Carbon Impact Assessment report;
5. Deliver consultation on impact on customers' electrical installations or appliances from the *eta* Method;
6. **Deliver Optimisation Implementation Strategy for adoption of *eta* across GB on all Network Management System solutions.**

### Evidence (9.4)

#### Research Workstream

1. Publish on *eta* website an interim and final HV and LV Voltage and Configuration Optimisation Study report by October 2016 and December 2017 respectively;
2. Publish on *eta* website an interim and final Retrofit Design and Operation of Interconnected LV Networks Study by October 2016 and December 2017 respectively;
3. Publish on *eta* website an interim and final Cost Benefit Assessment Study by October 2016 and December 2017 respectively;
4. Publish on *eta* website the interim and final Carbon Impact Assessment report by October 2016 and December 2017 respectively;
5. Publish on IET.TV and *eta* website the results from the consultation process on impact on customers' electrical installations from application of the *eta* Method by December 2017;
6. **Produce and publish Optimisation Implementation Strategy and make available for dissemination by October 2017.**

### Criteria (9.5)

#### Learning & Dissemination Workstream

1. Develop and launch the *eta* Project website and social media forums;
2. Produce project progress materials **for** internal general awareness and a series of advertorials detailing *eta*'s progress;
3. Attend Annual LCN Fund Conferences, produce *eta* Webinars and hold *eta* Knowledge Sharing Events;
4. Make raw monitoring data available on demand via *eta* website;
5. Issue *eta* six monthly Project Progress Reports to Ofgem and on *eta* website.

### Evidence (9.5)

#### Learning & Dissemination Workstream

1. *eta* website and social media forums live by July 2014;



## Low Carbon Networks Fund Full Submission Pro-forma Successful Delivery Reward Criteria continued

- 2a. Publicise *eta* within Electricity North West in Monthly Team Brief pack and Volt (intranet) and/ or Newswire (bimonthly staff magazine) by January 2014, September 2014, June 2015, October 2016 and October 2017;
- 2b. Publish advertorials by July 2014, July 2015, October 2015, October 2016 and December 2017;
3. Active participation at four Annual LCN Fund Conferences from 2014 to 2017, two *eta* Webinars held by July 2014 and April 2015, and three *eta* Knowledge Sharing Events by October 2015, October 2016 and September 2017;
4. Raw monitoring data is available via *eta* website by December 2015;
5. Project Progress Reports issued in accordance with Ofgem's June and December production cycle and publish on *eta* website.

### Criteria (9.6)

#### Close Down & Business as Usual Handover Phase

1. Produce the *eta* Close Down Report;
2. Update Electricity North West's Network Design Policy to define *eta* as the intervention strategy for LCT clustering.

### Evidence (9.6)

#### Close Down & Business as Usual Handover Phase

1. *eta* Close Down Report issued to Ofgem and published on *eta* website by December 2017;
2. Publish on *eta* website Electricity North West's approach to managing LCT clustering by December 2017.

# Low Carbon Networks Fund

## Full Submission Pro-forma

### Section 10: List of Appendices

- Appendix A**      **eta Technical Description**  
This appendix describes at a high level the technical architecture, features and operating methods of the *eta* Project.
- Appendix B**      **Site Selection Methodology**  
This appendix details the method, developed by TNEI and Electricity North West, for selecting the Trial networks for the *eta* Project.
- Appendix C**      **Organogram**  
This appendix details the management structure for delivery of the *eta* Project, highlighting the main deliverables for each of the five Workstreams and where the Project Partners contribute to their delivery.
- Appendix D**      **Project Partner and Supplier Details**  
This appendix describes each Project Partner, its roles and responsibilities in the delivery of the *eta* Project. In addition the details on the ownership and contractual relationship with Electricity North West and its financial contribution to *eta* are described.
- Appendix E**      **Risks and Issue Register and Contingency**  
This appendix outlines Electricity North West's Risks and Issues methodology. The risks, issues, mitigating actions and the contingency arrangements are detailed for the *eta* Project.
- Appendix F**      **Detailed Project Plan**  
This appendix details the proposed Project Plan for the delivery of the *eta* Project.
- Appendix G**      **Business Case Analysis & Method and Base Case Calculations**  
This appendix details the analysis from TNEI comparing traditional reinforcement against the *eta* Method completed for the *eta* Project Business Case; plus an explanation of the calculation for the Method and Base Cases **and future cost reduction assumptions**.
- Appendix H**      **Carbon Impact Assessment**  
This appendix contains the Executive Summary of the Tyndall Manchester's Carbon Impact Report.
- Appendix I**      **Indicative Customer Engagement Plan**  
This appendix contains the draft Customer Engagement Plan for the planned customer communications during the delivery of the *eta* Project.
- Appendix J**      **Letters of support from Project Partners, Suppliers and Supporters**  
This appendix contains a letter of support from all of our Project Partners. The support letters indicate the innovation of *eta* detailing each Partners' commitment to the *eta* Project.
- Appendix K**      **References**
- Appendix L**      **eta Full Submission spreadsheet**  
This appendix is the Full Submission Workbook for the *eta* Project. This will be appended in a separate document.

## Appendix A *eta* Technical Description

### Background

This technical paper outlines proposals for methodologies to facilitate the successful implementation of the *eta* project. A high level outline of the operating principles and proposed functionality is provided; including the expected implementation methods of the various products and software algorithms.

In order to meet the decarbonisation challenge laid down by the Government customers will be encouraged to adopt new Low Carbon Technologies (LCT). These technologies fall into two distinct groups:

- Load; and
- Generation.

Low carbon **loads** such as heat pumps and electric vehicles will increase demand and drive voltage down. These loads may also alter the demand profile, particularly with the charging of electric vehicles overnight and the use of heat pumps in cold weather. Low carbon **generation**, such as Photovoltaic Cells (PV), or wind generation will have the opposite effect and boost the network voltage from the point of connection. This is particularly of concern when the generation is connected at domestic customer premises in large quantities. PV in particular can cause significant over voltage issues with prolific generation during sunny days when domestic load is likely to be at a minimum.

The combination of these technologies operating on the low voltage network can make managing the network voltage in real time and within statutory limits a considerable challenge. Given the nature of the operation of these LCTs, it can lead to an increase in network losses, particularly reactive losses. Network losses account for between 5% and 8% of energy distributed to end customers with around 70% of these network losses incurred on the high voltage (HV) and low voltage (LV) networks. These losses are inherent in any electrical system and are dependent on the current flowing and the physical characteristics. Losses have the effect of reducing the available network capacity. Therefore there is a need to consider how to improve the losses caused by the LCTs.

### Equipment

The project will expand on techniques explored in previous LCN Fund Second Tier projects and utilise the following products and equipment developed or investigated under IFI and First Tier projects; WEEZAPs, LYNXs, capacitors and distribution transformers with on load tap changers.

#### WEEZAP

The **WEEZAP** is an LV vacuum circuit breaker combined with an advanced measurement and protection processing unit jointly developed between Kelvatek and Electricity North West under an IFI project. The WEEZAP contains the following innovative functionality:

1. Retrofit design – The WEEZAP is designed to be fitted directly to existing LV fuse panels in replacement of the fuse. It is not necessary to replace the LV board itself. Fitting is fast and simple with the minimum of training;
2. Circuit Breaker Switching – The WEEZAP has the ability to close and open the circuit at the LV substation either locally or remotely;
3. Protection & reclose functionality – The WEEZAP will provide protection by opening the circuit breaker in overload and fault conditions. Configuration settings allow local automated re-closing; alternatively reclose control can be via the Network Management System (NMS). The WEEZAP can:
  - Provide circuit breaker protection where fuses were traditionally used;
  - Allow reclosing, either automatic or remotely via the NMS;
  - Intelligent protection can be reconfigured for cold load pickup or protection of distant networks previously unprotected by fusing;
  - Minimise response times to fault incidents, reduce staff visits to site;
  - Lower CI, CML figures through a combination of reconfiguration and reclosing.
4. Communications – The WEEZAP communicates with the Gateway device which provides a remote connection to the installed devices. This will allow remote monitoring and control.

5. Monitoring – The WEEZAP measures voltage, current, power factor, real power, apparent power, reactive power, frequency, THD, and individual harmonics including magnitude and phase up to the 25th. Data intervals can be configured to calculate the mean values over a range from 1 minute to 1 hour. 10ms minimums and maximums are also recorded over this period. The WEEZAP can:
  - Detect over and under voltage conditions/confirm voltage within limits;
  - Monitor currents for overload and assess duration and magnitude of overloads;
  - Check harmonic levels on the network;
  - Use power flow information at NMS level to make network configuration decisions.
  - Capture high speed data to diagnose network problems, including incipient fault detection and location.
6. Fault Location – Transient waveform data is interpreted to give a distance to fault before the fault becomes permanent which will reduce the time to locate and repair network faults.

### LYNX

The **LYNX** is an LV vacuum switch developed by Kelvatek. The LYNX contains the following innovative functionality:

1. Retrofit design – The LYNX is designed to be fitted directly to existing LV link boxes in replacement of the solid link or fuse. It is not necessary to replace the link box itself. Fitting is fast and simple with the minimum of training;
2. Switching – The LYNX has the ability to close and open the circuit at the link box either locally or remotely;
3. Communications – The LYNX communicates with the Gateway device which provides a remote connection to the installed devices. This will allow remote monitoring and control;
4. Monitoring – The LYNX measures voltage, current, power factor, real power, apparent power, reactive power, frequency, THD, and individual harmonics including magnitude and phase up to the 25th. Data intervals can be configured to calculate the mean values over a range from 1 minute to 1 hour. 10ms minimums and maximums are also recorded over this period.

### Capacitors

These will be used on the HV and LV networks to provide further points of voltage control and linearise the voltage profile. These products will be installed at strategic points along the HV and LV feeders in accordance with results from network studies. The Optimisation software will switch the capacitors directly and/or communicate voltage set points to the capacitor controllers. In the event of a loss of communications then by using these set points, the local controller can decide whether to add or remove the capacitance from the network based on the set point. Both HV and LV capacitors are standard products offered by a few manufacturers and will be sourced via a competitive tender. Current IFI and First Tier projects are investigating the installation and operation of these capacitors and the findings of these projects will inform *etc.*

### Distribution Transformers with On Load Tap changers

These products will be installed in the local distribution substation to assist with voltage regulation and will operate via an automatic voltage control relay. The Optimisation software will communicate with the voltage control relay and alter the voltage set points. The installation and operation of these products is being investigated in an existing First Tier project.

### NMS Requirements and Communication Interface

The Electricity North West NMS will require modifications to include the LV networks in the Trial – there is currently no LV network in the NMS. The current HV building blocks will be used to draw the LV networks under trial in the NMS. This network will come under the remit of the control engineer.

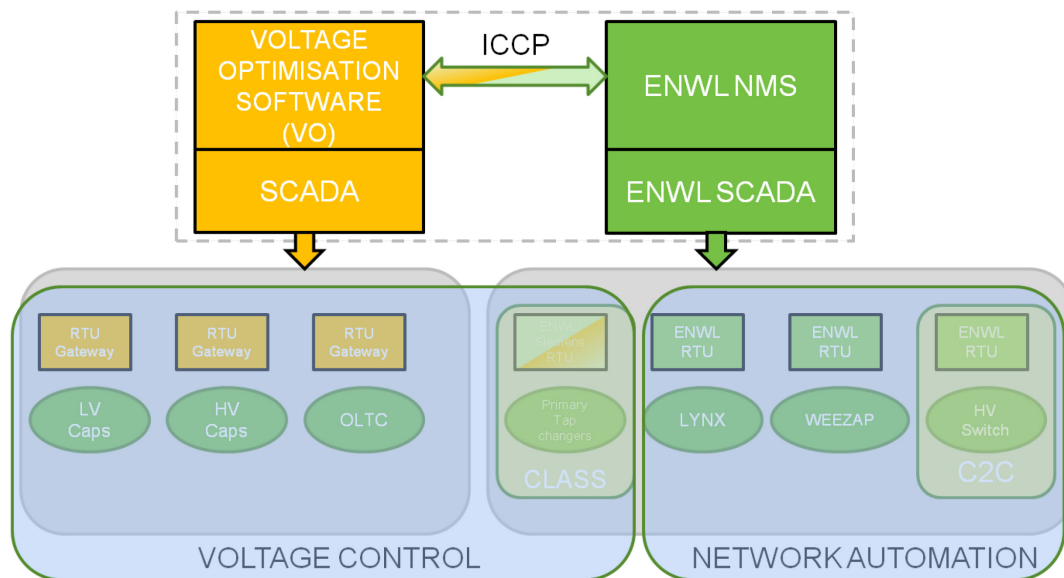
There will be a requirement to label the Trial networks and adequately brief all relevant staff to ensure that they are aware of the new operating regime. All work carried out on the Trial networks shall be controlled by the control engineer as per the current operating regimes for

the HV network. All network diagrams shall be updated in a timely manner so that the correct information can be passed to the Optimisation software. There will be multiple communications paths for the *eta* Project as shown in Figure A.1 below.

All switching commands will be instructed from the Electricity North West NMS whilst the control commands, ie change of voltage set points, will be issued directly from the Siemens Spectrum Power software.

One communications route not detailed in the diagram is the route for the monitoring information. Currently all the monitoring equipment on the Electricity North West network communicate via iHost and the Spectrum Power software will need to interface with iHost to pick up this information.

Figure A.1 Communications and Control



### Optimisation Software

The Optimisation software is part of the already available Spectrum Power system from Siemens. Spectrum Power will be the central component in this project that will facilitate, manage and control the numerous schemes and devices. Spectrum Power will be responsible for optimising the operation of both the LV and HV networks. Spectrum Power currently has in-built optimisation targets to;

- minimise power loss; or to
- minimise power demand; or to
- maximise generated reactive power; or to
- maximise revenue:

whilst satisfying voltage and loading constraints and operating in real time.

A small modification will be required to the algorithms to allow the loss minimisation objective to be applied at HV, while the power demand minimisation is applied at LV.

### Interfacing

Spectrum Power will be interfaced with the Electricity North West NMS via an Inter Control Communications Protocol (ICCP) link. The protocol will require some development from Electricity North West to ensure effective real time two-way communication. Devices in the field on both the LV and HV network will communicate all their real time data to Spectrum Power via RTUs. Spectrum Power will directly control some devices in the field on the LV network via its inbuilt SCADA functionality. However, the commands for the switching devices on the network, as well as the primary tap changers, will be communicated to the field devices via the Electricity North West NMS.

## Development of Network Model

The network information will be provided to Spectrum Power from Electricity North West in the form of Common Information Model (CIM) files. The files will include all the network data such as all analogue information and circuit status. Switch state changes will be exchanged on an event by event basis. Spectrum Power will require detailed circuit data (line lengths, reactance, etc) as well as network topology to construct the network structures and power flows.

Depending on the granularity of the data, the developed network models may require some user adjustments to render an accurate representation of the network – this is a one-off task.

The load profile models for the LV network will be developed from the standard load profiles imported from Electricity North West. The load profile models on the HV network will use 30 minutes historical load profiles in either CSV or CIM format.

## Operator Interface

Spectrum Power will provide clear LV network representation within the Electricity North West Control Room that will present Electricity North West with real time visibility of the status of the LV network. There will be remote desktop access for LV management. The level of access will be limited via passwords and user defined levels of security.

## Measurement and monitoring

Measurement and monitoring on the *eta* project is required for two purposes. The first is the measurement of the voltage at the various points on the network to provide inputs to the algorithm. It is anticipated that the algorithm will calculate a 30 minute average measurement. For the inputs to the algorithm the voltages will be required at:

- HV busbars and strategic points on the HV network; and
- LV busbars and strategic points on the LV network.

There are currently voltage measurements available on the HV busbars via existing transducers. There is an existing First Tier project installing measurement points at LV busbars and along the feeders on the LV network. Some work may have to be carried out if the voltages at points on the HV network are required.

The second requirement is to quantify the energy savings seen by customers and to quantify the losses reduction. Measurements will be recorded at various points on the LV network using monitoring built into the WEEZAP, LYNX and the mid/end point smart joint (developed under a First Tier project). This monitoring will provide all currents, voltages, real power, reactive power and harmonics (where required). Electricity North West needs to stipulate the sampling rate for each of these parameters.

The sampling rate for the data provided to the Optimisation software can be lower than that required for the research element of the Project. It is envisaged that the Optimisation software will run every 30 minutes whilst 1 minute data may be required to allow the full data analysis required to prove the success of the project. Monitoring data will be obtained from a number of different systems and therefore due consideration shall be given to the need for data warehousing in addition to existing Electricity North West systems.

## Installation and commissioning

Electricity North West will look to conduct a competitive tender for an installation and commissioning contract. This contract will cover all the equipment apart from the WEEZAP, LYNX and Gateway. These devices will be installed by Electricity North West authorised staff supported by Kelvatek.

## Appendix B Description of the methodology for the selection of Trial networks within the *eta* Project

### Introduction

This Appendix describes the methodology that is proposed for the selection of high voltage (HV) and low voltage (LV) circuits to be included within the *eta* Trial. The same approach could be applied by other distribution network operators (DNOs) using the *eta* Method. The proposed methodology has been developed to allow the selection of representative samples covering different circuit types, customer types and uptake of low carbon technologies.

Three Trial areas covering five Primary substations will be identified to demonstrate rural, urban and dense urban circuits and load patterns. For meaningful results, two Primary substations will be selected in each of the urban and dense urban categories and one in the rural. More circuits may be selected in some of the categories than others to ensure the collection of representative Trial results. The overall number of circuits is expected to be of the order of 10 HV and 160 LV, in a combination which reflects the range of different circuit classifications detailed in Table B1, Rural/Urban Classification Table on page 4.

The circuits selected using this approach will cover the range of network constraints that would usually require the reinforcement of distribution networks using a traditional approach, and that the *eta* Project looks to mitigate. These constraints include thermal loading levels and voltage limits. The proposed methodology will use learning from the Western Power Distribution Low Voltage Network Templates Project and also target areas where there have been clusters of Low Carbon Technology installations such as PV arrays and electric heat. A specific opportunity to align *eta* with another project funded by the Japanese Development Organisation, NEDO, and supported by Greater Manchester Combined Authority exists; 300 Heat Pumps are to be installed in social housing properties within the Wigan and north Manchester areas during the *eta* Trial period.

The Trial areas contain a mix of private and social housing which will give Electricity North West the added benefit of applying the Method in areas where there are a number of customers who fall within the fuel poverty classification bringing immediate assistance to those customers through reducing energy consumption and potentially leading to a lower bill for electricity during the Trial duration.

It is assumed that the circuits selected for inclusion within the Trial are being operated at present with a typical radial network topology. It is also assumed that the existing network configuration complies with ENA Engineering Recommendation P2/6.

*eta* will, where practicable, interconnect radial feeders and operate as an interconnected network. In the event of a fault on the system, the configuration of the network will revert back to the traditional (ie radial) topology using automated switching.

### Description of circuit selection methodology

The circuit selection methodology is outlined below, using the following steps:

Figure B1 selection methodology steps



Each of these steps is described in more detail overleaf.

## Step 1: Initial circuit screening

Considering the full portfolio of HV and LV circuits within the three Trial areas (rural, urban and dense urban), it is first necessary to select those circuits that will best demonstrate the *eta* Method. Secondly, preference will be given to those HV and LV circuits which are ultimately fed from a Primary substation that has been involved in either of the C<sub>2</sub>C or CLASS Project Trials to optimise the use of assets already installed.

## Step 2: Circuit classification

Circuits will be classified according to the following criteria:

1. Voltage levels;
2. Circuit types;
3. Customer types;
4. Low Carbon technology uptake; and
5. Physical Constraints.

### *Voltage levels*

The following voltage levels are considered in the circuit selection methodology, in order to maximise the learning outcomes and applicability to other GB distribution networks:

- 11kV & 6.6kV; and
- 415V.

### *Circuit types*

The following categories of circuit type are considered in the circuit selection methodology, based on the number of connected customers, defined as:

- Dense urban;
- Urban;
- Rural.

The LV circuits will be classified against the LV network templates developed within the Western Power Distribution Low Voltage Network Templates Project.

### *Customer type*

Existing customers may be categorised as:

1. Generation connections;
2. Domestic load demand connections;
3. Combined domestic load and generation connections;
4. Commercial load demand connections;
5. Industrial load demand connections;
6. Combined commercial or industrial load and generation connections.

### *Locations with Low Carbon Technologies fitted by Registered Social Landlords and/ or Private Individuals*

Those circuits with known LCTs connected (either DG or new LCT demands eg Heat Pumps and/or Electric Vehicles) will be chosen in order to show how these networks can be operated by the *eta* Method. Where possible networks with cluster of LCTs will be identified to assess the impact on these devices with the application of the *eta* Method and to understand the potential capacity and voltage headroom that can be created compared with traditional reinforcement. Where no LCTs are connected, preference will be given to all electric heat circuits.

### *Physical Constraints*

Consideration shall be given to the following when selecting the sites:

1. Is there space available to install the new equipment?
2. Indoor or Outdoor? As the on load tap changer equipment can only be installed in indoor substations.
3. The potential for installation without planned supply interruptions. This will be achievable where back feed or connection of generation connection is possible.



4. Availability of pre-existing interconnection points (Link Boxes) alleviating the need for extra equipment.

### **Step 3: Preliminary circuit selection**

Following the classification of the circuits, a preliminary circuit selection will be made in order to obtain a representative set of circuits for the project Trial. A number of statistical methods may be employed to select the circuits within each category.

### **Step 4: Circuit simulation and refined selection**

For meaningful results, two Primary substations have been selected in each of the urban and dense urban categories and one in the rural. More circuits may be selected in some of the categories than others to ensure the collection of GB representative Trial results; however, there should be flexibility in terms of the number of circuits selected and contained within each category to ensure use of those that have the potential to demonstrate the Project benefits.

The set of preliminary circuits will be simulated to identify any power flow, voltage or fault level issues that may arise as a result of operating two radial feeders as an interconnected network (either as a closed loop from a substation or interconnection between two substations).

The historic evolution of parts of the Electricity North West distribution system, as well as previous design policies based on economic considerations and the number of customers requiring supply, means that some circuits may be tapered or may have sections of smaller capacity anywhere along the circuit. The change to the network topology (and thus the change to impedance paths in the network) that result from the operation of the distribution network in interconnected configurations could lead to the re-distribution of power flows. Forming interconnection between radial feeders to create an interconnected network is likely to increase fault levels slightly however not fault duties.

The following protection issues have been identified, which could influence HV circuit selection:

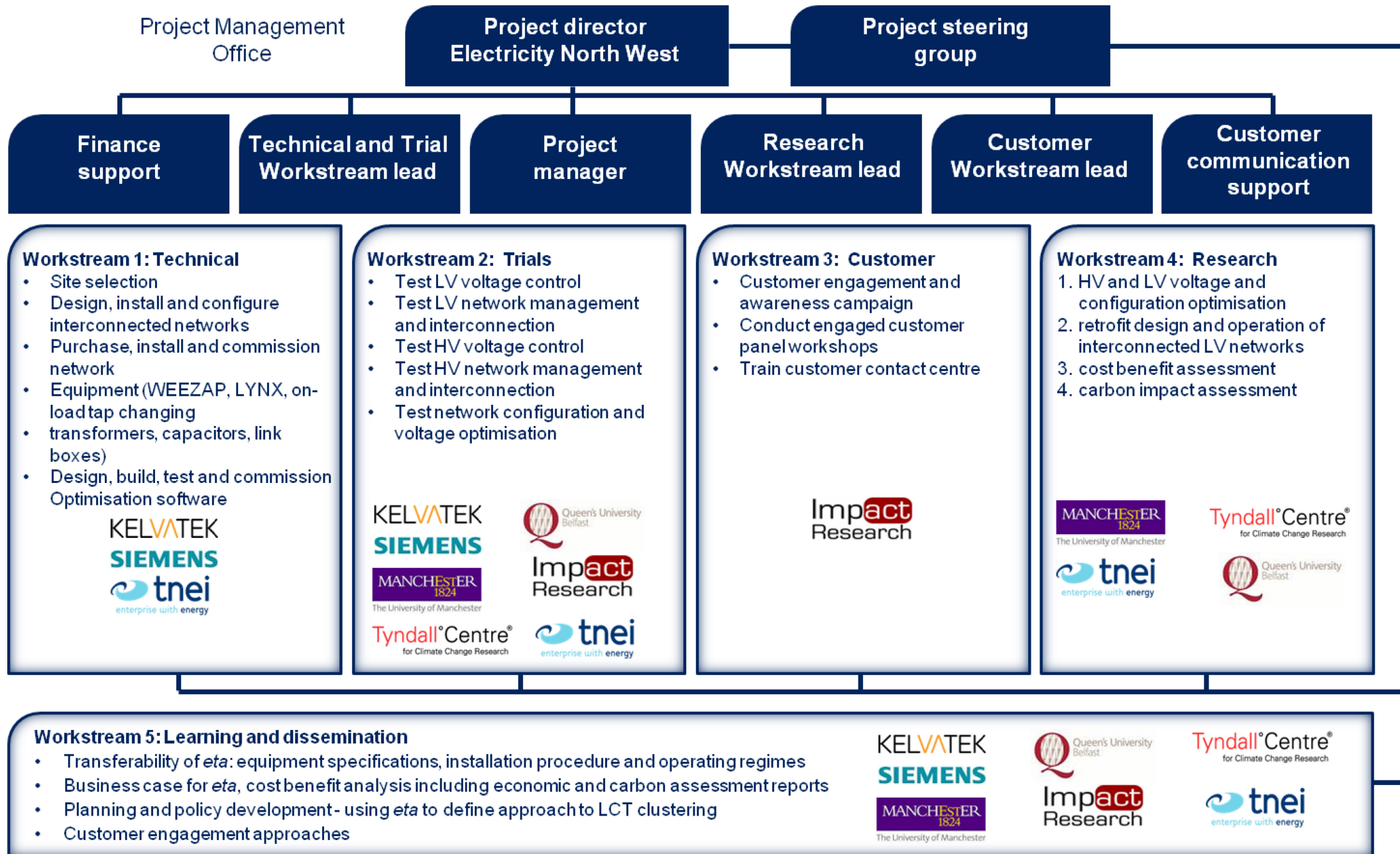
- The lockout, as a result of sensitive earth faults (SEFs), could prevent the protection system re-closing on overhead line sections;
- There is potential for a closed circuit to occur between dead and live sections at a primary due to busbar blocking schemes;
- There are possible problems with feeding overhead lines from both ends due to the potential for non-operation of protection schemes.

This more detailed assessment may lead to a number of iterations in the circuit selection process as circuits are selected and subsequently eliminated.

**Table B1 – Rural/Urban Classification Table**

	HV1 Urban Underground Radial	HV2 Urban Underground Meshed	HV3 Suburban Underground Radial	HV4 Suburban Underground Meshed	HV5 Suburban Mixed Radial	HV6 Rural Overhead Radial	HV7 Rural Mixed Radial	HV8													LV17 Meshed Suburban street ( 3 4 bed semi	LV18 Meshed New build housing estate	LV19 Meshed Terraced street	LV20
	LV1 Central Business District	LV2 Dense urban (apartments etc)	LV3 Town centre	LV4 Business park	LV5 Retail park houses)	LV6 Suburban street ( 3 4 bed semi detached or detached houses)	LV7 New build housing estate	LV8 Terraced street	LV9 Rural village (overhead construction)	LV10 Rural village (underground construction)	LV11 Rural farmsteads small holdings	LV12 Meshed Central Business District	LV13 Meshed Dense urban (apartments etc)	LV14 Meshed Town centre	LV15 Meshed Business park	LV16 Meshed Retail park								
EHV1 Urban Underground Radial	100.00%	0.00%	0.00%	0.00%	0.00%	0.00%	0.00%	0.00%	0.00%	0.00%	0.00%	0.00%	0.00%	0.00%	0.00%	0.00%	0.00%	0.00%	0.00%	0.00%	0.00%	0.00%		
EHV2 Urban Underground Meshed	0.00%	100.00%	0.00%	0.00%	0.00%	0.00%	0.00%	0.00%	0.00%	0.00%	0.00%	0.00%	0.00%	0.00%	0.00%	0.00%	0.00%	0.00%	0.00%	0.00%	0.00%	0.00%		
EHV3 Suburban Mixed Radial	0.00%	0.00%	62.00%	0.00%	0.00%	38.00%	0.00%	0.00%	0.00%	0.00%	0.00%	0.00%	0.00%	0.00%	0.00%	0.00%	0.00%	0.00%	0.00%	0.00%	0.00%	0.00%		
EHV4 Suburban Mixed Meshed	0.00%	0.00%	10.00%	65.00%	25.00%	0.00%	0.00%	0.00%	0.00%	0.00%	0.00%	0.00%	0.00%	0.00%	0.00%	0.00%	0.00%	0.00%	0.00%	0.00%	0.00%	0.00%		
EHV5 Rural Overhead Radial	0.00%	0.00%	0.00%	0.00%	10.00%	55.00%	35.00%	0.00%	0.00%	0.00%	0.00%	0.00%	0.00%	0.00%	0.00%	0.00%	0.00%	0.00%	0.00%	0.00%	0.00%	0.00%		
EHV6 Rural Mixed Radial	0.00%	0.00%	0.00%	0.00%	12.00%	29.00%	59.00%	0.00%	0.00%	0.00%	0.00%	0.00%	0.00%	0.00%	0.00%	0.00%	0.00%	0.00%	0.00%	0.00%	0.00%	0.00%		
EHV7	0.00%	0.00%	0.00%	0.00%	0.00%	0.00%	0.00%	0.00%	0.00%	0.00%	0.00%	0.00%	0.00%	0.00%	0.00%	0.00%	0.00%	0.00%	0.00%	0.00%	0.00%	0.00%		
EHV8	0.00%	0.00%	0.00%	0.00%	0.00%	0.00%	0.00%	0.00%	0.00%	0.00%	0.00%	0.00%	0.00%	0.00%	0.00%	0.00%	0.00%	0.00%	0.00%	0.00%	0.00%	0.00%		
LV1 Central Business District	5.80%	18.40%	10.50%	0.00%	0.00%	0.00%	0.00%	65.30%	0.00%	0.00%	0.00%	0.00%	0.00%	0.00%	0.00%	0.00%	0.00%	0.00%	0.00%	0.00%	0.00%	0.00%		
LV2 Dense urban (apartments etc)	9.40%	18.80%	15.60%	0.00%	0.00%	0.00%	0.00%	56.30%	0.00%	0.00%	0.00%	0.00%	0.00%	0.00%	0.00%	0.00%	0.00%	0.00%	0.00%	0.00%	0.00%	0.00%		
LV3 Town centre	0.00%	0.00%	2.50%	10.00%	5.00%	15.00%	15.00%	52.00%	0.00%	0.00%	0.00%	0.00%	0.00%	0.00%	0.00%	0.00%	0.00%	0.00%	0.00%	0.00%	0.00%	0.00%		
LV4 Business park	0.00%	0.00%	2.50%	24.00%	5.00%	52.00%	10.00%	6.50%	0.00%	0.00%	0.00%	0.00%	0.00%	0.00%	0.00%	0.00%	0.00%	0.00%	0.00%	0.00%	0.00%	0.00%		
LV5 Retail park houses)	0.00%	0.00%	0.00%	7.50%	6.50%	26.00%	30.00%	30.00%	0.00%	0.00%	0.00%	0.00%	0.00%	0.00%	0.00%	0.00%	0.00%	0.00%	0.00%	0.00%	0.00%	0.00%		
LV6 Suburban street ( 3 4 bed semi detached or detached houses)	0.00%	0.00%	0.00%	1.00%	0.00%	0.00%	3.00%	1.00%	42.00%	44.00%	9.00%	0.00%	0.00%	0.00%	0.00%	0.00%	0.00%	0.00%	0.00%	0.00%	0.00%	0.00%		
LV7 New build housing estate	0.00%	0.00%	0.00%	1.00%	0.00%	0.00%	4.00%	1.00%	42.00%	44.00%	8.00%	0.00%	0.00%	0.00%	0.00%	0.00%	0.00%	0.00%	0.00%	0.00%	0.00%	0.00%		
LV8 Terraced street	0.00%	0.00%	0.00%	0.00%	0.00%	0.00%	0.00%	0.00%	0.00%	0.00%	0.00%	0.00%	0.00%	0.00%	0.00%	0.00%	0.00%	0.00%	0.00%	0.00%	0.00%	0.00%		
LV9 Rural village (overhead construction)																								
LV10 Rural village (underground construction)																								
LV11 Rural farmsteads small holdings																								
LV12 Meshed Central Business District																								
LV13 Meshed Dense urban (apartments etc)																								
LV14 Meshed Town centre																								
LV15 Meshed Business park																								
LV16 Meshed Retail park																								
LV17 Meshed Suburban street ( 3 4 bed semi detached or detached houses)																								
LV18 Meshed New build housing estate																								
LV19 Meshed Terraced street																								
LV20																								

## Appendix C: Organogram



## Appendix D Project Partner and Supplier Details

Name	Type of Organisation	Different Ownership from DNO	Funding Provided	Contractual Relationship	Role of Project Partner	Funding Benefits to Project
Siemens	Siemens is one of the world's leading suppliers of power generation and energy delivery technologies	Yes		Terms & Conditions agreed, requires contract drafting and the inclusions of work schedules for <i>eta</i>	<ul style="list-style-type: none"> <li>Supply, install and configure the Optimisation hardware and software</li> <li>Support in executing Trial</li> <li>To produce an Optimisation Implementation Strategy for DNOs using other NMS solutions</li> <li>Learning &amp; Dissemination Support</li> </ul>	Siemens is funding the Optimisation software licenses and software development enhancement required to achieve the <i>eta</i> Method. Use of The Crystal as a conference venue.
Kelvatek	Kelvatek is the UK leader in LV switching, automation and fault management technology. It has an exceptional record of bringing innovative product solutions to the power industry through a robust R&D pipeline, combined with unique LV high current test facilities.	Yes		Terms & Conditions agreed, requires contract drafting.	<ul style="list-style-type: none"> <li>Supply WEEZAP and LYNX devices</li> <li>Support in executing Trial</li> <li>Learning &amp; Dissemination Support</li> </ul>	Kelvatek will provide training on the installation and operation of WEEZAP and LYNX. Experienced Kelvatek field staff will attend site to provide advice and on the job training, or support and advice by telephone. Kelvatek will also issue manuals and other training materials relating to the operation of the new equipment.
Impact Research	Impact Research is a specialist marketing research organisation	Yes		Terms & Conditions agreed, requires contract drafting and the inclusions of work schedules for <i>eta</i>	<ul style="list-style-type: none"> <li>Customer engagement and survey activities</li> <li>Reports on customer experience of <i>eta</i>.</li> <li>Learning &amp; Dissemination Support</li> </ul>	Impact Research is providing funding for all of its own knowledge and dissemination activities.
TNEI	TNEI is experienced in all aspects of power generation, transmission and distribution, with particular expertise in network modelling	Yes		Framework agreement is in place, just requires the inclusion of work schedules for <i>eta</i>	<ul style="list-style-type: none"> <li>Network design</li> <li>Manage the consultation process</li> </ul>	N/A

Queen's University Belfast	Queen's University is an academic institution	Yes		Framework agreement to be agreed and inclusion of work schedules for <i>eta</i>	<ul style="list-style-type: none"> <li>• Delivery of <b>two</b> studies as part of <i>eta</i></li> <li>• Support in executing Trials</li> <li>• Learning &amp; Dissemination Support</li> </ul>	N/A
University of Manchester	The University of Manchester is an academic institution	Yes		Framework agreement is in place, just requires the inclusion of work schedules for <i>eta</i>	<ul style="list-style-type: none"> <li>• Delivery of three studies as part of <i>eta</i></li> <li>• Support in executing Trials</li> <li>• Learning &amp; Dissemination Support</li> </ul>	N/A
Tyndall Manchester Climate Change Research	Carbon Research Institution (part of the Uni. Of Manchester)	Yes		Framework agreement is in place, just requires the inclusion of work schedules for <i>eta</i>	<ul style="list-style-type: none"> <li>• Carbon study and Impact assessment</li> <li>• Learning &amp; Dissemination Support</li> </ul>	N/A

## Appendix E: Risks and Issues Register

The risk model employed by Electricity North West in the delivery of LCNF Tier 2 Project Delivery looks at risks in much the same holistic manner as the proven risk model employed by Electricity North West at a corporate level. However, using previous experience, the Risk and Issues Register has been refined to better reflect the increased significance of impacts at a Project level. In this model, Risk Impact Areas have been categorised into Time, Cost and Scope/Quality which are given a score of 1 to 5 along with the likelihood of occurrence. The resulting product of these two ratings is used to score and rank the risks on the Project. The format of the ENWL Tier 2 Risk Scoring Matrix is below.

### Risk Impact Descriptors

RISK AREA	1 Negligible	2 Minor	3 Moderate	4 Significant	5 Serious
<b>Time</b>	There will be no impact on deliverables. No re-planning necessary.	Any delays are likely to be small ie <1 week and manageable. Minor re-planning necessary.	Some delays likely to Project/ Programme milestones, but the overall Project/ Programme delivery date will not be affected. An element of re-planning will be necessary.	There is likely to be a delay which causes the overall Project/ Programme delivery end-date to slip. Significant re-planning will be essential.	There is likely to be a delay which causes the overall Project/ Programme delivery end-date to slip. Serious re-planning will be essential.
<b>Cost</b>	£0	<£10k	<£20k	<£50k	>£50k
<b>Scope/ Quality</b>	There will be no impact on the overall quality of the deliverables in the Project/Programme. All requirements will still be met.	There will be negligible impact (if any), on the overall quality of the deliverables in the Project/Programme. Most, if not all requirements will still be met.	Some requirements will not be met, or a small number of business process(es) will need to be modified to accommodate shortcomings in the delivery.	A significant number of requirements will not be met, or business process(es) will need to be modified to accommodate shortcomings in the delivery.	Major requirements, key to the success of the delivery are not likely to be delivered as planned.

### Risk Probability Descriptors

<b>5</b>	Almost Certain	>80%
<b>4</b>	Likely	60-80%
<b>3</b>	Moderate	30-60%
<b>2</b>	Low	10-30%
<b>1</b>	Rare	<10%

### Risk Score

<b>Impact</b>	<b>5</b>	5	10	15	20	25
	<b>4</b>	4	8	12	16	20
	<b>3</b>	3	6	9	12	15
	<b>2</b>	2	4	6	8	10
	<b>1</b>	1	2	3	4	5
		<b>1</b>	<b>2</b>	<b>3</b>	<b>4</b>	<b>5</b>
		<b>Probability</b>				

The following potential risks have been identified. These risks have been based on the scoring matrix set out above and linked to the Project Phase or Workstream in which they will likely occur. The risk headings identified by Ofgem in their "Guidance for Low Carbon Networks Fund Project Progress Reports" document (issued on 14th May 2013) are also referenced for clarity.

Project Phase / Workstream	Description ( <i>Delivery Risk Category</i> )	Probability Score	Impact Score	Mitigating Action/ Contingency Action	Revised Probability	Revised Impact Score
<b>Phase I: Mobilisation</b>	<b>ALL PARTNERS:</b> There is a risk that ENWL and/or Partners are not able to mobilise their resources in time because of other commitments. This may lead to a delay in achieving key milestones and deliverables. <b>(Other)</b>	3	5	<ol style="list-style-type: none"> <li>1. A comprehensive Project Plan with clearly defined timescales and milestones will be agreed with Project Partners, internal delivery team and other stakeholders.</li> <li>2. Framework Agreements with clear Terms &amp; Conditions will be agreed and put in place with all Partners.</li> </ol>	1	5
				<i>Contingency</i> <i>Review Project Plan and consider options to achieve milestones should this risk crystallise.</i>		
<b>Phase II: Site Selection, Network Design &amp; Equipment Tendering</b>	<b>ENWL:</b> There is a risk that following preliminary design, planning issues where equipment is proposed to be located could lead to extended consultation requirements. This could compromise optimal equipment positioning and cause delays to the start of the Trial. <b>(Installation)</b>	3	3	<ol style="list-style-type: none"> <li>1. ENWL will engage early to inform customers of local works, thus minimising risks of objections. Furthermore, any installation of equipment will be planned to minimise intrusion and disturbance, whilst maximising advantageous positions for delivery of benefits.</li> </ol>	3	2
				<i>Contingency</i> <i>Alternative additional feeders will be identified, that could be used if delays expected to exceed milestones.</i>		
<b>Phase II: Site Selection, Network Design &amp; Equipment Tendering</b>	<b>ENWL:</b> There is a risk that the Trial areas selected will not include areas with CLASS or C <sub>2</sub> C leading to a lost opportunity to gain further value from utilising existing assets. <b>(Other)</b>	4	5	<ol style="list-style-type: none"> <li>1. Contingency costs will be allocated in the budget for monitoring, remote control or voltage control equipment to be purchased and installed at a selected eta site; if it is not feasible to use existing CLASS and C<sub>2</sub>C assets.</li> </ol>	4	1
				<i>Contingency - n/a</i>		
<b>Phase II: Site Selection, Network Design &amp; Equipment Tendering</b>	<b>ENWL:</b> There is a risk that a lack of suitable equipment vendors may result in a poor response to Invitations for Tenders, leading to reduced competitiveness of quotes and reduced value for money. <b>(Procurement)</b>	4	5	<ol style="list-style-type: none"> <li>1. RFI in eta development showed that products are available from a number of vendors, but some vendors require further development.</li> <li>2. Various utilities vendor database will be interrogated to maximise coverage and reach of Invitations to Tender.</li> </ol>	2	4
				<i>Contingency</i> <i>Early vendor engagement and development.</i>		
<b>WS1: Technology</b>	<b>ENWL:</b> There is a risk that actual product delivery lead times may be greater than planned due to supply constraints around some of required technologies eg On Load Tap Changing	3	5	<ol style="list-style-type: none"> <li>1. The Technology phase commences in July 2014, allowing for completion of a rigorous procurement process to identify suitable vendors who can meet the work schedule. Clearly defined timescales will also be included in all tenders and vendor agreements to ensure that project timescales are met.</li> </ol>	2	5

	Transformers, Capacitors, Link Box Switches and RTUs which could lead to installation delay and start of the Trial. <b>(Procurement)</b>			<i>Contingency</i> <i>Flexibility has been built into the installation programme should this risk crystallise.</i>		
<b>WS1: Technology</b>	<b>ENWL &amp; SIEMENS:</b> There is a risk that the vendor does not achieve delivery and installation of the Optimisation software or that there are potential constraints with ENWL NMS configuration and commissioning. This could lead to a delayed start of the <i>eta</i> Trials. <b>(Installation)</b>	3	5	1. Earlier identification of vendor for discussion and agreement to deliver to Project Plan. 2. Early identification by Electricity North West of constraints to NMS configuration.	2	5
				<i>Contingency</i> <i>Electricity North West resources supplemented by external personnel.</i> <i>Implement Optimisation within new NMS.</i>		
<b>WS1: Technology</b>	<b>ENWL, PARTNERS &amp; EQUIPMENT PROVIDERS:</b> There is a risk that new technologies or software installed do not perform as expected in commissioning stage leading to delays to commencing the Trial and potentially impacting the quality of <i>eta</i> outputs. <b>(Installation)</b>	4	5	1. All <i>eta</i> equipment technologies have been trialed and proven under previous IFI and LCNF Tier 1 funded projects; or proven in business as usual scenarios.	2	5
				<i>Contingency</i> <i>Plan for early commissioning dates with contingency time should this risk crystallise.</i>		
<b>WS2: Trials</b>	<b>ENWL:</b> There is a risk that customers in the Trial areas perceive a change to their electricity supply leading to hypothesis failure and potential adverse publicity for <i>eta</i> . <b>(Other)</b>	2	5	1. Extra monitoring equipment may be installed to validate the claim and ensure that the perceived change is not due to the customer being sensitised to the Trial.	2	5
				<i>Contingency</i> <i>If it is proved that quality of supply is outside statutory/ acceptable limits then temporarily halt Trial in that area and seek remedies to rectify situation for Trial to continue whilst providing reassurance to our customers and stakeholders.</i>		
<b>WS2: Trials</b>	<b>ENWL:</b> There is a risk that the survey group does not form a representative sample of either the ENWL or GB customer base. <b>(Other)</b>	3	5	1. Customers recruited for the Trial surveys will be representative of the wider population at both ENWL and GB level and be matched by ACORN classification.	1	5
				<i>Contingency</i> <i>Target customers for customer survey to achieve representative sample and monitor drop-outs to ensure sample remains representative.</i>		



<b>WS2: Trials</b>	<b>ENWL:</b> There is a risk that some industrial customers have transformer winding ratios of 11000/415 leading to out of limit voltages on their networks. <b>(Other)</b>	2	2	1. Search for potential customers in Trial area and inform customers of <i>eta</i> Trials.	2	2
				<i>Contingency – n/a</i>		
<b>WS3: Customer</b>	<b>ENWL:</b> There is a risk that external factors, not directly influenced by the Trials or related to <i>eta</i> , could cause customers to become negative towards ENWL or LCN Fund Projects. <b>(Other)</b>	3	5	1. The <i>eta</i> project team will work closely with the Electricity North West Press Officer to identify any potential issues and formulate targeted communication to proactively minimise any adverse impacts to <i>eta</i> .	3	2
				<i>Contingency ENWL may temporarily halt the Trials in that area until our customers are reassured of the benefits of eta Trials.</i>		
<b>WS3: Customers</b>	<b>ENWL:</b> There is a risk that there may be some confusion amongst customers due to other ongoing government initiatives, eg The Green Deal and Smart Metering roll out program. This could lead to customer engagement being adversely affected. <b>(Recruitment)</b>	5	5	1. The <i>eta</i> Customer Engagement Plan is both non-intrusive and simple, thus minimising the potential for confusion with other government initiatives.	2	5
				<i>Contingency More communication and engagement to remove the confusion and differentiate the role and activities of ENWL and eta.</i>		
<b>WS4: Research</b>	<b>RESEARCH PARTNERS:</b> There is a risk that the University of Manchester or Queen's University, Belfast undergo personnel changes during the Project, leading to loss of specific skills which could impact the quality of deliverables. <b>(Other)</b>	2	3	1. Work packages agreed with the Universities will define the tasks each university is responsible for. 2. All research activities will be undertaken in a collaborative manner, with involvement of multiple individuals across both academic institutions.	2	2
				<i>Contingency Reallocate activities within or across universities to ensure specific skills can be applied to eta.</i>		
<b>WS5: Learning &amp; Dissemination</b>	<b>ENWL:</b> There is a risk that the high volume of LCN Fund events will dilute the effectiveness of dissemination activities leading to lower than expected value derived from <i>eta</i> being achieved. <b>(Other)</b>	4	5	1. Create strong Project branding, key messages and high-quality dissemination materials to ensure that <i>eta</i> is clearly differentiated and reaches the right audience. 2. Choice of dissemination media optimised to achieve maximum reach and coverage.	2	5
				<i>Contingency Extend the number and methods of dissemination activities to share the eta message.</i>		
<b>WS5: Learning &amp; Dissemination</b>	<b>ENWL:</b> There is a risk that the varied interests of stakeholders prevents knowledge from being disseminated effectively leading	4	5	1. During the preparation of <i>eta</i> submission, multiple communication channels and a range of stakeholders have been identified to maximise <i>eta</i> 's dissemination outcomes.	2	5

	to the learning outcomes from <i>eta</i> not being maximised. <b>(Other)</b>			<i>Contingency</i> <i>Monitor the effectiveness of each dissemination activity and amend as appropriate to ensure the eta messages are disseminated effectively.</i>		
--	---	--	--	---	--	--







ID	Task Name	Duration	Start	Finish	4th Qual	1st Qual	2nd Qu	3rd Qual	4th Qual	1st Qual	2nd Qu	3rd Qual	4th Qual	1st Qual	2nd Qu	3rd Qu	4th Qual	1st Qual	2nd Qu	3rd Qu	4th Qual	1st Qual								
					O	N	D	J	F	M	A	M	J	J	A	S	O	N	D	J	F	M	A	M	J	J	A	S	O	N
166	9.5.5 Project Progress Reports issued in accordance with Ofgem's June – December production cycle.	0 days	Mon 07/12/15	Mon 07/12/15																										
167	Preparation of Report 5	20 days	Mon 02/05/16	Fri 27/05/16																										
168	9.5.5 Project Progress Reports issued in accordance with Ofgem's June – December production cycle.	0 days	Mon 06/06/16	Mon 06/06/16																										
169	Preparation of Report 6	20 days	Tue 01/11/16	Mon 28/11/16																										
170	9.5.5 Project Progress Reports issued in accordance with Ofgem's June – December production cycle.	0 days	Mon 05/12/16	Mon 05/12/16																										
171	Preparation of Report 7	20 days	Mon 01/05/17	Fri 26/05/17																										
172	9.5.5 Project Progress Reports issued in accordance with Ofgem's June – December production cycle.	0 days	Mon 05/06/17	Mon 05/06/17																										
173	Preparation of Report 8	20 days	Wed 01/11/17	Tue 28/11/17																										
174	9.5.5 Project Progress Reports issued in accordance with Ofgem's June – December production cycle.	0 days	Mon 04/12/17	Mon 04/12/17																										
175	<b>Internal Learning &amp; Dissemination</b>	<b>1001 days</b>	<b>Mon 06/01/14</b>	<b>Tue 31/10/17</b>																										
176	Produce materials for Volt / Newswire Article 1 - Publicise eta	20 days	Mon 06/01/14	Fri 31/01/14																										
177	9.5.2 (a) Publicise eta within Electricity North West in Monthly Team Brief pack and Volt and/ or Newswire by Jan	0 days	Fri 31/01/14	Fri 31/01/14																										
178	Produce materisl for Volt / Newswire Article 2 - Progress & Learning	20 days	Mon 01/09/14	Fri 26/09/14																										
179	9.5.2 (a) Publicise eta within Electricity North West in Monthly Team Brief pack and Volt and/ or Newswire by Jan	0 days	Tue 30/09/14	Tue 30/09/14																										
180	Produce materials for Volt / Newswire Article 3 - Progress & Learning	20 days	Mon 01/06/15	Fri 26/06/15																										
181	9.5.2 (a) Publicise eta within Electricity North West in Monthly Team Brief pack and Volt and/ or Newswire by Jan	0 days	Tue 30/06/15	Tue 30/06/15																										
182	Produce materials for Volt / Newswire Article 4 - Progress & Learning	20 days	Mon 03/10/16	Fri 28/10/16																										
183	9.5.2 (a) Publicise eta within Electricity North West in Monthly Team Brief pack and Volt and/ or Newswire by Jan	0 days	Mon 31/10/16	Mon 31/10/16																										
184	Produce materials for Volt / Newswire Article 5 - eta live Trial end	20 days	Mon 02/10/17	Fri 27/10/17																										
185	9.5.2 (a) Publicise eta within Electricity North West in Monthly Team Brief pack and Volt and/ or Newswire by Jan	0 days	Tue 31/10/17	Tue 31/10/17																										
186	<b>Phase III - Close Down &amp; Long Term Project Handover</b>	<b>65 days</b>	<b>Mon 02/10/17</b>	<b>Sun 31/12/17</b>																										
187	<b>Decommissioning</b>	<b>60 days</b>	<b>Mon 02/10/17</b>	<b>Fri 22/12/17</b>																										
188	Decide which network equipment will require decommissioning	30 days	Mon 02/10/17	Fri 10/11/17																										
189	Decommission identified equipment	30 days	Mon 13/11/17	Fri 22/12/17																										
190	<b>Close Down Report</b>	<b>65 days</b>	<b>Mon 02/10/17</b>	<b>Sun 31/12/17</b>																										
191	Close down Report Draft	45 days	Mon 02/10/17	Fri 01/12/17																										
192	Review and approval of report	15 days	Mon 04/12/17	Fri 22/12/17																										
193	9.6.1 eta Close Down Report issued to Ofgem and published on eta website by December 2017	0 days	Sun 31/12/17	Sun 31/12/17																										
194	9.6.2 Publish on eta website Electricity North West's approach to managing LCT clustering by December 2017	0 days	Sun 31/12/17	Sun 31/12/17																										
195	<b>Project Closure</b>	<b>1 day?</b>	<b>Fri 29/12/17</b>	<b>Fri 29/12/17</b>																										

Project: eta Project Delivery Updated  
Date: Wed 16/10/13

Task Progress Summary External Tasks Deadline ↓  
Split Milestone Project Summary External Milestone

## Contents

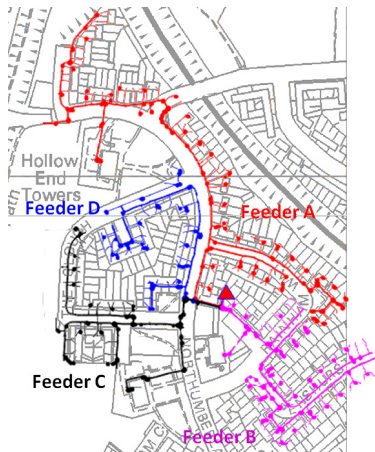
<b>1</b>	<b>INTRODUCTION</b> .....	<b>1</b>
<b>2</b>	<b>DUNTON GREEN NETWORK</b> .....	<b>2</b>
<b>3</b>	<b>METHODOLOGY</b> .....	<b>2</b>
<b>3.1</b>	<b>MODELLING TOOLS</b> .....	<b>2</b>
<b>3.2</b>	<b>LCT UPTAKE SCENARIOS</b> .....	<b>2</b>
<b>3.3</b>	<b>DEMAND AND GENERATION PROFILES</b> .....	<b>3</b>
<b>3.4</b>	<b>eta METHOD</b> .....	<b>3</b>
<b>3.5</b>	<b>TRADITIONAL REINFORCEMENT METHODS</b> .....	<b>4</b>
<b>4</b>	<b>NETWORK INTERVENTIONS ASSESSED</b> .....	<b>4</b>
<b>4.1</b>	<b>GENERATION LED REINFORCEMENT</b> .....	<b>4</b>
<b>4.2</b>	<b>DEMAND LED REINFORCEMENT</b> .....	<b>5</b>
<b>4.3</b>	<b>WORKSTREAM 3, SCENARIO 3 (WS3,S3) LED REINFORCEMENT</b> .....	<b>5</b>
<b>5</b>	<b>FINANCIAL BENEFITS</b> .....	<b>5</b>
<b>5.1</b>	<b>GENERATION GROWTH - CAPEX, OPEX &amp; CVR</b> .....	<b>6</b>
<b>5.2</b>	<b>DEMAND GROWTH - CAPEX, OPEX &amp; CVR</b> .....	<b>7</b>
<b>5.3</b>	<b>WORKSTREAM 3, SCENARIO 3 (HIGH EV &amp; HIGH HP GROWTH)</b> .....	<b>7</b>
<b>6</b>	<b>CONCLUSIONS OF THE eta METHOD</b> .....	<b>8</b>
<b>7</b>	<b>GB REPLICABILITY OF eta</b> .....	<b>8</b>



## 1 Introduction

TNEI have been commissioned by Electricity North West to provide support for their Tier 2 LCN Fund bid. In the *eta* project, voltage regulation equipment will be applied to HV and LV networks to manage the voltage profile along the circuits. Active network management equipment will be used to operate these networks in differing configurations (ie radial and interconnected). This application of real-time network configurations and voltage optimisation will deliver a reduction in networks losses and customers' energy consumption. The following is a condensed summary of the full study findings.

## 2 Dunton Green Network



The Dunton Green LV network located in the Stockport area has been chosen as a study case for applying the *eta* Method to determine its feasibility against traditional reinforcement. This area was considered based on previous studies undertaken by The University of Manchester and S&C Electric Europe Ltd.

This network contains 180 customers and primarily comprises of social housing supplied by four LV feeders. The area also contains three blocks high-rise flats, which are supplied by the HV network and have been assumed to consume no demand at LV.

Figure 2.1: Dunton Green LV network

## 3 Methodology

### 3.1 Modelling Tools

The power system analysis software package, IPSA 2 has been used to undertake the network analysis. This was used to study the voltage profile, thermal constraints and losses on the network under different scenarios.

### 3.2 LCT Uptake Scenarios

The Dunton Green network was used to quantify and estimate the annual investment of applying the *eta* Method compared to conventional reinforcement when LCT uptake and the growth expected in the next 25 years is considered.

The uptake of LCT was considered using the Transform Model developed by EA Technology. This model has four categories of predicted growth, the most likely scenario being of low PV, low HP and low EV uptake. This model of evenly distributed LCT uptake across the entire network however was not considered appropriate, as the uptake is most likely to be clustered on the network. The following scenarios were therefore considered:

1. **Clustered uptake of generation;** uptake of PV on 80% of the Dunton Green Network was considered in 4 time periods, over 1 year, 5 years, 10 years and 25 years;
2. **Clustered uptake of Domestic Heat Pumps (HP) and Electric Vehicles (EV);** uptake of HP and EV on 60% of the Dunton Green Network was considered in 4 time periods, over 1 year, 5 years, 10 years and 25 years. If only HP uptake is considered this is equivalent to 85% penetration; and
3. **Distributed uptake of LCT according to Workstream 3, High uptake model;** This considers growth according to the Transform model time period of 2012-2050.

The percentage of PV uptake was limited by the difficulty to provide conventional reinforcement to accommodate more generation without major investments. The percentage of HP and EV uptake was conversely limited to the capacity *eta* was able to supply before conventional reinforcement was required.



### 3.3 Demand and Generation Profiles

#### 3.3.1 Existing Demand Profile

Existing customer load is assumed to follow a diversified profile for modern semi-detached housing taken from the EA Technology Smart Grids Forum – Work Stream 3. This profile has an After Diversity Maximum Demand of 1.25kW.

#### 3.3.2 LCT Characteristics

Three types of LCT are considered based on the type of network. Dunton Green is a residential area, therefore only domestic installations were considered. The following details were considered for PV, HP and EV:

- PV installations on the LV network of 3.6 kW and 1.0 unity power factor were assumed;
- Domestic heat-pumps were added to the demand profile, these were assumed to have a flat profile with a diversified demand of 2.93kW and a power factor of 0.95; and
- EV charging at home (both fast and slow EV charge) were added to the demand profile, these were assumed to have a flat profile with a diversified demand of 1.2kW and a power factor of 0.95.

### 3.4 *eta* Method

The *eta* Trial is a method of reinforcement to the network which will realise three key benefits, which will be scalable to the whole GB distribution network. The key elements of the Method are:

- Installation of on-load tap changers or capacitors at secondary substations;
- Installation of capacitors at HV and/or LV along feeders; and
- Interconnection of LV networks.

These three techniques will together provide benefits to the network by:

- Reducing the cost of provision of incremental capacity;
- Reducing the average LV voltage and thereby providing energy efficiencies for customers, this is known as Conservation Voltage Reduction (CVR);
- Reducing the losses on the systems; and
- Releasing capacity on the network.

The *eta* Method is comprised of two techniques which can be applied in stages:

1. Voltage optimisation using capacitors and/or adjusting the transformer taps. This can be undertaken in the following steps:
  - a. Install capacitors along LV circuit to linearise the voltage profile.
  - b. Adjust taps on the existing transformer and install capacitor at the substation; or install an on load tap changing transformer (OLTC) to control the sending end voltage i.e. reduce voltage to provide voltage headroom;
2. Interconnection of radial feeders. The degree of interconnection will depend on the required need for voltage headroom on the particular circuit. This may involve interconnecting only two radial feeders or may involve interconnection of many radial feeders. This can be applied in stages depending on the required capacity and predicted timeliness of the required capacity.

LV interconnection in *eta* can also include interconnections between HV/LV substations.

Interconnection involves the following steps:

- a. Interconnect networks by:
  - Replacing fuses at the substation with WEEZAPs;
  - Replacing link box links with LYNX (link box switches); and
  - Extending the functionality of the Network Management System (NMS) software to manage the LV network.



- b. Install new optimisation functionality to manage real-time configuration and voltage optimisation.

### 3.5 Traditional Reinforcement Methods

To compare the benefits of the *eta* Method, traditional reinforcement methods were first considered on the network to provide additional capacity. Traditional reinforcement typically involves the following set of reinforcements.

- Split loads through jointing and/ or link box insertion or re-positioning;
- Cable overlay with larger cable and transfer existing services onto new cable;
- Install larger transformer if there are capacity constraints;
- Split LV networks, new J loop from existing substation with new LV board; and
- New substation, new mains cable to split existing networks and load.

The number of reinforcements will be determined by the required capacity required and timeliness to meet the demand. It may be seen as more appropriate to immediately install a new substation if the capacity required is unable to be gained through less costly reinforcements.

## 4 Network Interventions Assessed

### 4.1 Generation Led Reinforcement

This scenario examines the network when reinforcement of the network is driven by PV uptake to 80% penetration of the Dunton Green Network. The timing of the reinforcements will depend on the timeliness of the uptake of generation based on the 1 year, 5 year, 10 year and 25 year uptake periods studied.

#### *eta* Method

#### Traditional Reinforcement

<i>eta</i> Method	Cost	Planning + Installation Time	Capacity (kW)	% of PV
None	-	-	0-260kW	40%
██████████	██████████	8 days	261-464 kW	72%
██████████	██████████	29 days	464-552 kW	85%
██████████	-	6 days	552-616 kW	95%
██████████	-	-	Beyond 616 kW	95%+
<b>TOTAL</b>	<b>£133,966</b>	<b>43</b>		

Traditional Reinforcement	Cost	Planning + Installation Time	Capacity (kW)	% of PV
None	-	-	0-260kW	40%
Overlay Cable – Feeder A	£34,300	24 days	261-364 kW	56%
Overlay Cable – Feeder D	£20,563	18 days	364-379 kW	58%
Overlay Cable – Feeder B	£14,950	16 days	379-402 kW	62%
Overlay Cable – Feeder C	£17,550	15 days	402-409 kW	63%
Further Overlay – Feeder B	£27,088	23 days	409-433 kW	67%
Further Overlay – Feeder A	£19,425	17 days	433-434 kW	67%
Further Overlay – Feeder D	£13,488	17 days	434-454 kW	70%
Further Overlay – Feeder C	£17,825	17 days	454-468 kW	72%
Install new LV Panel + J-loop	£22,125	15 days	468-473 kW	73%
Install J-loop+ Further Overlay	£23,725	19 days	Beyond 473 kW	73%+
<b>TOTAL</b>	<b>£211,038</b>	<b>181</b>		



## 4.2 Demand Led Reinforcement

This scenario examines the network when reinforcement of network is driven by HP and EV uptake to 60% penetration of the Dunton Green Network. The timing of the reinforcements will depend on the timeliness of the uptake of generation based on the 1 year, 5 year, 10 year and 25 year uptake periods studied.

### eta Method

eta Method	Cost	Planning + Installation Time	Capacity (kW)	% EV & HP
None	-	-	0-189 kW	25%
██████	██████	8 days	189-222 kW	30%
██████████	██████	8 days	222-278 kW	37%
██████	██████	6 days	278-324 kW	44%
██████████	██████	3 days	324 kW-494kW	66%
<b>TOTAL</b>	<b>£76,844</b>	<b>25</b>		

### Traditional Reinforcement

Traditional Reinforcement	Cost	Planning + Installation Time	Capacity (kW)	% EV & HP
None	-	-	0-189kW	25%
Overlay Cable-Feeder A	£34,300	24 days	189-264 kW	36%
Replace Transformer	£15,000	6 days	264-381 kW	51%
New Secondary Substation + New HV & LV cables	£50,950	30 days	381-420 kW	56%
Further Overlay - Feeder A	£14,800	23 days	Beyond 420 kW	56%+
<b>TOTAL</b>	<b>£115,050</b>	<b>83</b>		

## 4.3 Workstream 3, Scenario 3 (WS3,S3) Led Reinforcement

The growth of PV using Workstream 3, scenario 3 is the high PV, high HP and high EV growth rate evenly distributed across the entire Electricity North West network.

Under growth of PV no reinforcement on the existing network is required up to 2040. The growth of HP and EV will trigger reinforcements in 2039, these are detailed below.

### eta Method

eta Method	Cost	Planning + Installation Time	Capacity (kW)	% of EV & HP
None	-	-	0-189 kW	25%
██████	██████	8 days	189-222 kW	30%
<b>TOTAL</b>	<b>£16,391</b>	<b>8</b>		

### Traditional Reinforcement

Traditional Reinforcement	Cost	Planning + Installation Time	Capacity (kW)	% of EV & HP
None	-	-	0-189kW	25%
Overlay Cable-Feeder A	£34,300	24 days	189-264 kW	36%
<b>TOTAL</b>	<b>£34,300</b>	<b>24</b>		

## 5 Financial Benefits

The table below summarises the net present value (NPV) CAPEX and OPEX benefits of eta over the 2015-2040 period compared to traditional reinforcement under different growth rates for both generation and demand led reinforcement. The tables show that the NPV of the uptake of LCTs over 1 year, 10 years and 25 years. There is benefit of eta for uptake of generation, and for longer progressive uptake of HP and EV. During rapid growth of EV and HP alone, the benefit of traditional reinforcement is better as the decrease in losses is



much more significant due to the installation of a new secondary substation as opposed to incremental reinforcements.

There are also additional benefits of *eta* in terms of energy efficiencies which will be seen by customers, this is displayed in the following table.

NPV	CAPEX		OPEX	Capitalised Value for DNO		Benefit of <i>eta</i>
	<i>eta</i>	Traditional	Losses*	<i>eta</i>	Traditional	
<b>Generation</b>						
1 yr	£125,554	£197,786	-£4,963	£120,591	£197,786	£77,195
10 yrs	£72,579	£120,934	-£3,130	£69,449	£120,934	£51,485
25 yrs	£31,407	£55,146	-£1,398	£30,009	£55,146	£25,137
<b>Demand</b>						
1 yr	£73,542	£107,826	£26,856	£100,397	£107,826	£7,429
10 yrs	£54,604	£71,127	£10,685	£65,289	£71,127	£5,838
25 yrs	£32,723	£37,831	-£1,173	£31,550	£37,831	£6,281

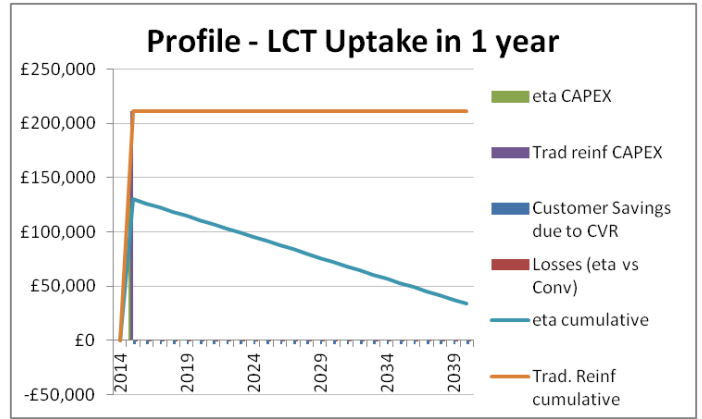
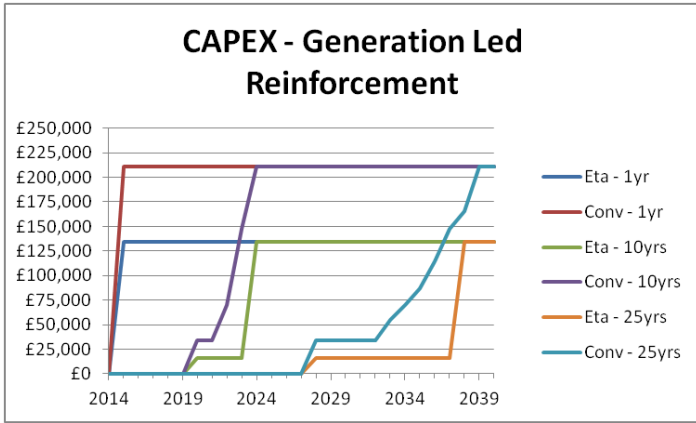
\*Losses are compared to traditional reinforcement, therefore are applicable only to *eta*.

NPV	CAPEX		OPEX	Additional Benefits of <i>eta</i> for Customers	Net Capitalised Value		Benefit of <i>eta</i>
	<i>eta</i>	Traditional	Losses*	CVR	<i>eta</i>	Traditional	
<b>Generation</b>							
1 yr	£125,554	£197,786	-£4,963	-£41,882	£78,709	£197,786	£119,077
10 yrs	£72,579	£120,934	-£3,130	-£21,419	£48,030	£120,934	£72,905
25 yrs	£31,407	£55,146	-£1,398	-£3,386	£26,623	£55,146	£28,523
<b>Demand</b>							
1 yr	£73,542	£107,826	£26,856	-£27,103	£73,295	£107,826	£34,531
10 yrs	£54,604	£71,127	£10,685	-£14,211	£51,078	£71,127	£20,049
25 yrs	£32,723	£37,831	-£1,173	-£3,508	£28,042	£37,831	£9,789

### 5.1 Generation Growth - CAPEX, OPEX & CVR

The figure below, on the left shows the timing of the interventions described above for generation led reinforcement for different uptake periods.

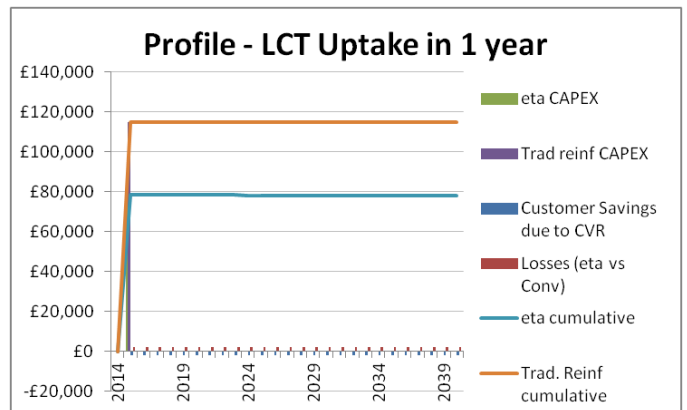
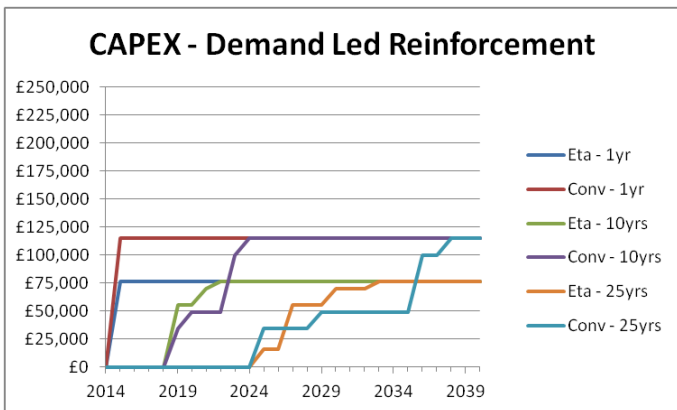
The figure on the right shows the cash flow profile when PV uptake to 80% penetration of the Dunton Green network takes place over 1 year. The top line indicates the cumulative conventional reinforcement costs, while the bottom line indicates the cumulative *eta* reinforcement costs. The decreasing cost is due to the savings of losses and CVR. The benefit of reduced losses is taken relative to traditional reinforcement therefore for traditional reinforcement the expenditure profile is constant. The decrease in costs is dominated by the savings from CVR. The studies are based on maximum demand and a constant load factor. However in reality this will not be the case and therefore increased benefits from reduced losses could be seen.



### 5.2 Demand Growth - CAPEX, OPEX & CVR

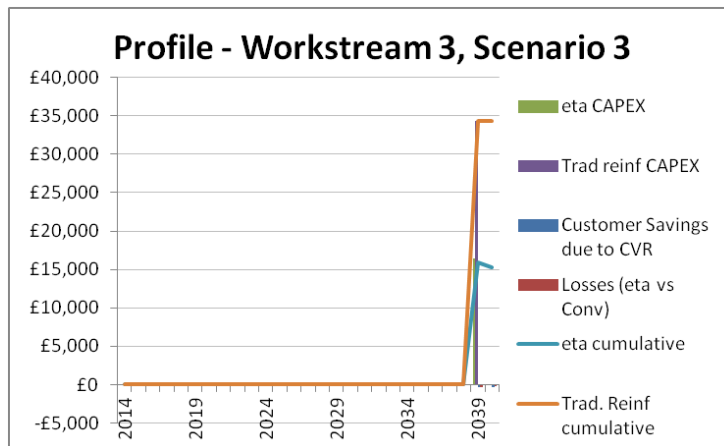
The figure below on the left shows the timing of the interventions described above for demand led reinforcement for different uptake periods.

The figure on the right shows the cash flow profile when HP and EV uptake to 60% penetration of the Dunton Green network takes place over 1 year. The top line indicates the cumulative conventional reinforcement costs, while the bottom line indicates the cumulative *eta* reinforcement costs. The cumulative cost of *eta* remains almost constant as the savings achieved from CVR are negated by the cost of losses compared to traditional reinforcement. When the uptake period is only a year the traditional reinforcement includes the installation of a new substation which will significantly reduce losses in comparison to the *eta* method.



### 5.3 Workstream 3, Scenario 3 (High EV & High HP Growth)

The time period for this scenario is defined by the Workstream 3 growth predictions. This uptake can be seen as optimistic as there is no clustering and the need for reinforcement is not seen until 2039. Under this scenario only a one intervention is required to meet expected LCT growth which is significantly less expensive to implement using *eta*.



## 6 Conclusions of the *eta* Method

The *eta* Method provides benefit compared to traditional reinforcement when there is a clustered uptake of LCT's and under distributed growth across the network using Workstream 3.

As *eta* is made up of multiple phases which can be applied gradually benefits can be realised in delayed expenditure.

In addition due to the benefits of Conservation Voltage Reduction, savings will not only be seen in capital expenditure, but customers will be able see the direct savings of the *eta* scheme. It is these benefits which provide significant added value over time.

The benefits of *eta* are clearly shown when there is high growth of generation. However the savings are not as significant for demand growth. If HP and EV growth is foreseen to be rapid then application of *eta* should be applied with more caution. For instance the cost of energy should be compared. The analysis carried out has assumed a cost of losses of 4.842p/kWh based on Ofgem figures. If this were to increase the savings for rapid HP and EV uptake may be diminished.

## 7 GB Replicability of *eta*

The replicability of the *eta* Project has been determined using the categories of LV network defined in the Workstream 3 Transform model, using best engineering judgement. From this assessment it was determined GB represented 13.28 times the Electricity North West network. This was then used to scale up the potential CAPEX savings for GB from the roll out of *eta* compared to traditional reinforcement.

Information obtained as part of the LCN Fund project 'LV Network Templates' undertaken by Western Power Distribution in South Wales has been considered to determine Dunton Green's representation of the Electricity North West network. This project suggests the network can be clustered into 10 different profiles. Based on these profiles, Dunton Green fits into the profile of Domestic Customer Dominated, high demand (Cluster 1).

To determine the applicability of the method to GB it was found using an assessment carried out by Electricity North West that the *eta* method could be applied to approximately 3 out of 4 (75%) of feeders at a distribution substation.

Type of LV Feeder	ENW		GB		Potential for Roll-out			Number of applications	
	Number of LV Feeders	Proportion of ENW (%)	Number of LV Feeders	Proportion of GB (%)	Voltage Optimisation	LV Meshing	ETA	ENW	GB
LV1 Central Business District	1961	2%	16,246	1.7%	75%	75%	75%	1,471	12,185
LV2 Dense urban (apartments etc)	6223	8%	50,099	5.2%	75%	75%	75%	4,667	37,574
LV3 Town centre	3928	5%	32,154	3.3%	75%	75%	75%	2,946	24,116
LV4 Business park	2413	3%	70,119	7.3%	0%	75%	75%	1,810	52,589
LV5 Retail park	1330	2%	13,502	1.4%	0%	75%	75%	998	10,127
LV6 Suburban street (3-4 bed semi detached or deta	4565	6%	122,765	12.7%	75%	75%	75%	3,424	92,074
LV7 New build housing estate	5734	7%	149,493	15.5%	75%	75%	75%	4,301	112,120
LV8 Terraced street	32829	40%	336,922	34.9%	75%	75%	75%	24,622	252,692
LV9 Rural village (overhead construction)	10053	12%	24,122	2.5%	0%	0%	0%	-	-
LV10 Rural village (underground construction)	10532	13%	24,802	2.6%	75%	0%	75%	7,899	18,602
LV11 Rural farmsteads small holdings	2058	3%	4,993	0.5%	0%	0%	0%	-	-
LV12 Meshed Central Business District	0	0%	6,179	0.6%	75%	0%	75%	-	4,634
LV13 Meshed Dense urban (apartments etc)	0	0%	13,284	1.4%	75%	0%	75%	-	9,963
LV14 Meshed Town centre	0	0%	11,677	1.2%	75%	0%	75%	-	8,758
LV15 Meshed Business park	0	0%	12,096	1.3%	0%	0%	0%	-	-
LV16 Meshed Retail park	0	0%	2,520	0.3%	0%	0%	0%	-	-
LV17 Meshed Suburban street (3-4 bed semi detach	0	0%	26,208	2.7%	75%	0%	75%	-	19,656
LV18 Meshed New build housing estate	0	0%	5,040	0.5%	75%	0%	75%	-	3,780
LV19 Meshed Terraced street	0	0%	44,482	4.6%	75%	0%	75%	-	33,362
<b>Totals</b>	<b>81,627</b>	<b>8.4% (of GB)</b>	<b>966,703</b>	<b>100%</b>	<b>63.9% (of ENW) 71.6% (of GB)</b>			<b>52137</b>	<b>692229</b>

KEY	not economical
	already meshed

Scale Factors	
Trial -> ENW	325.86
ENW -> GB	13.28

This table is an extract from a full report by TNEI – '8531-01 – Energy Efficient Networks.'



Part of the Petrofac group



## Appendix G2 Method and Base Case calculations

TNEI's network analysis of Dunton Green substation showed that the *eta* Method was viable and provided significant reduction in costs and implementation time whilst delivering increased capacity release. Table G1 below shows the comparison between costs, capacity release and implementation time for the demand and generation led reinforcement scenarios.

Table G1 Cost, capacity and implementation time for Dunton Green interventions

<b>Generation</b>	<b>eta Method</b>	<b>Traditional</b>
Asset cost, £	£133,966	£211,038
Capacity released, kW	291	227
Capacity released, kW/ circuit	73	57
Capacity released, £/ kW	£460	£930
Planning & Installation time, days	43	181
<b>Demand</b>	<b>eta Method</b>	<b>Traditional</b>
Asset cost, £	£78,469	£115,050
Capacity released, kW	305	231
Capacity released, kW/ circuit	76	58
Capacity released, £/ kW	£257	£498
Planning & Installation time, days	25	83

To create the Base Case and Method Case for the *eta* Project it was assumed that there were an equal number of generation and demand led reinforcements across the 40 distribution substations / 160 LV circuits. Table G2 below shows the comparison between the Base Case costs and capacity release for the *eta* Project. It was assumed that although more capacity is released under the *eta* Method, it would be set to the value released by Traditional methods, as it is uncertain the additional capacity release would occur at other substations.

Table G2 *eta* Project Base Case cost and capacity release

LV circuit analysis	<i>eta</i>		scaled <i>eta</i>		Traditional	
	Cost	kW	Cost	kW	Cost	kW
<b>Generation</b>	£2,679,320	5,820	£2,679,320	4,540	£4,220,750	4,540
<b>Demand</b>	£1,569,380	6,100	£1,569,380	4,620	£2,301,000	4,620
Total	£4,248,700	11,920	£4,248,700	9,160	£6,521,750	9,160

Table G3 below shows the results of applying the scaling factors of 326 and 13.26, proposed by TNEI, to indicate the potential roll-out scale for Electricity North West and GB of the *eta* Method. Table G4 below shows the Dunton Green interventions were scaled to the *eta* Project, assuming the same resources available to undertake both methods.

Table G3 *eta* Solution capacity release scaled to Electricity North West and GB

	<b>Generation</b>	<b>Demand</b>	<b>Total</b>
<b>Capacity/ feeder, kW</b>	57	58	
<b>eta Project, MW</b>	4.54	4.62	9.16
<b>ENWL, MW</b>	1,479	1,505	2,985
<b>GB, MW</b>	19,642	19,988	39,630

Table G4 Implementation time to scaled to *eta* Project

		<b>Generation</b>	<b>Demand</b>	
<b>Per LV circuit</b>	<b>eta, weeks</b>	2.15	1.25	
	<b>Traditional, weeks</b>	9.05	4.15	<b>Total</b>
<b>eta Project</b>	<b>eta, months</b>	43	25	<b>11.3</b>
	<b>Traditional, months</b>	181	83	<b>44</b>



Table G5 below shows the expected future costs savings and associated assumptions for the technical equipment to apply the *eta* Method, when proven.

Table G5 Future Cost Savings and Assumptions

<b>Equipment</b>	<b>Cost saving %</b>	<b>Assumption</b>
<b>LV network equipment</b>		
<i>WEEZAPs and LYNX</i>	25%	New entrants enter market and compete on price
<i>On Load Tap Changing Distribution Transformers</i>	15%	Second generation employ efficient manufacturing techniques to reduce price
<i>Capacitors</i>	15%	New UK demand stimulates supply chain
<i>Joint monitoring</i>	15%	Cheaper components and quicker installation techniques reduce costs
<b>HV network equipment</b>		
<i>Capacitors</i>	15%	New UK demand stimulates supply chain
<i>Voltage controllers</i>	50%	New uses stimulate demand and operational and installation methodologies reduce costs
<b>NMS &amp; interface</b>	20%	Interface specs and methodologies reduce costs
<b>Network configuration &amp; voltage optimisation</b>	40%	Operating regimes reduce configuration costs

## Appendix H Executive Summary eta Carbon Impact Assessment

*This document is a summary of fuller work providing a detailed estimate of the emission changes anticipated in the eta project. It has been prepared by Dr John Broderick at the Tyndall Centre (University of Manchester) with input from Simon Brooke (ENWL).*

### 1 Overview

The *eta* Method has the potential to substantially influence the carbon emissions<sup>1</sup> of the networks it is applied to. In the short term it will use different assets to release the same capacity as traditional reinforcement, and over time it will result in different line losses and potentially lower customer energy consumption. This report is a preliminary estimate of the carbon impact of these changes and the implications for the cost benefit analysis for the *eta* Method. It has found that the *eta* Method results in substantially less, of the order of 10%, carbon impact in terms of the assets used to release capacity. If deployed across the Electricity North West network this could save between 240,000 and 600,000 tCO<sub>2</sub>e, or at GB scale between 3 and 8 million tCO<sub>2</sub>e.

Over time the reduced losses associated with traditional reinforcement can see the benefits of lower *eta* assets outweighed in the mid 2020s, depending upon the uptake of Low Carbon Technologies (LCTs). Net carbon benefits might therefore be as high as 2 million tCO<sub>2</sub>e for Electricity North West and 30 million tCO<sub>2</sub>e at GB scale over the 25 year period of calculation, or as low as -1.4 million for Electricity North West or -18 million tCO<sub>2</sub>e for GB. This is predominantly a result of high losses on the network in all circumstances should a rapid growth in consumer demand due to LCTs be realised. The plausibility of such circumstances and the financial acceptability of a traditional programme of reinforcement is, however, questionable. Indeed, when the carbon impact is converted to a monetary value at DECC advised carbon prices, and discounted appropriately, it is seen that in only two of twelve cases would it not be favourable in the long term to opt for *eta*. Further research during the *eta* Project would seek to identify the particular circumstances under which *eta* Method may not realise net carbon benefits.

### 2 Methodology

The main carbon impacts identified in the *eta* Project relate to the *assets*, ie the emissions embodied in the physical equipment required to provide a service, *operational* impacts, namely the different quantities and locations and energy consumed by operating the network in this way relative to "business as usual" (BAU), and *CVR* impacts as a result of reduced energy consumption by customers due to Conservation Voltage Reduction (CVR). Carbon impacts were derived from TNEI modelling of the Dutton Green substation's LV network and the associated HV network under three scenarios over 25 years:

1. clustering of PV with 75% penetration (Generation clusters);
2. clustering of EVs and HPs with 60% penetration (Demand clusters); and
3. High penetration of EVs, PVs and HPs (Scenario3 of the Transform model, WS3\_S3).

The modelling identified the type and timing of the requirement for conventional reinforcement (BAU) and the *eta* Method, network losses and the additional energy saving benefit from the application of CVR. The carbon impacts were subsequently estimated as outlined below and the implications were then scaled up to the whole of the Electricity North West and GB networks.

#### 2.1 Asset Carbon

The assets used in the *eta* and conventional reinforcement were catalogued (eg lengths of cable required, number of WEEZAP, controllers, transformers etc) and the carbon embodied in each estimated from lifecycle assessment studies. Data was drawn from

<sup>1</sup> "Carbon emissions" is used as shorthand for all greenhouse gas emissions reported by the UK to the UNFCCC.

Electricity North West's own estimates of the mass of materials in the assets it installs and distances/vehicles/fuels associated with transport to site, as well as from the suppliers of specific assets themselves (eg LV capacitors).

## 2.2 Operational Carbon

The TNEI modelling shows that the change in the assets and operation under the *eta* Method and the different scenarios effect the energy lost on the network. The difference between the impact of conventional reinforcement and of *eta* and existing was calculated in each case. This MWh figure was then translated to a quantity of carbon emissions using the grid emissions intensity trend provided in the Ofgem RIIO-ED1 CBA template. This falls through time as electricity supply is expected to move towards lower carbon sources, however, the figures given are most likely an under estimate for these purposes as the marginal emissions intensity of the grid is somewhat higher than the average intensity (Hawkes 2010). An estimate was also made of the direct energy consumption in assets installed for the *eta* Method (WEEZAPs, LV Capacitors and computer servers for voltage optimisation).

## 2.3 CVR Carbon

The TNEI modelling estimates the energy saving due to *eta* Conservation Voltage Reduction (CVR) versus conventional reinforcement and operation. This quantity of energy is converted to a mass of carbon emissions as per operational carbon. TNEI assumed a CVR factor of 0.6 (the ratio of energy saving to voltage reduction) based on assumptions of the composition of UK household demand and in comparison to the range observed in comprehensive US studies (0.336-1.103). As CVR is highly dependent on load diversity in each individual household and without a large scale UK precedent these emissions reductions are likely to be of the correct order of magnitude but are somewhat uncertain.

## 2.4 Scaling

TNEI has estimated the relative proportions of Electricity North West and GB feeders that the *eta* Method would be applicable to. The total impact and asset carbon in isolation were scaled for comparison. Some circuits do not have the potential for both LV interconnection and voltage optimisation so the relevant components of carbon impacts were scaled in such cases. Scaling was performed only for Generation clusters and Demand clusters scenarios as the WS3\_S3 scenario was found to require negligible reinforcement by either *eta* or conventional means.

## 2.5 Analytical boundaries

Emissions reductions facilitated by the project, for instance by the increased uptake of electric vehicles, are not included. The use of generalised emissions factors and data sources, as well as a number of simplifying assumptions, mean that these figures are credible approximations in advance of the full carbon impact assessment within the project. A sensitivity analysis will be conducted to assess the impact of wider changes outside of project itself, eg grid emissions factor, LCT uptake rates. As was noted in previous Electricity North West LCN Fund project submissions, emissions reductions calculated in the power sector (operations and CVR) should be regarded as notional rather than physical due to the restrictions imposed by the EU ETS. In practice the EU ETS is substantially over supplied with emissions permits and there appears to be little or no abatement occurring in Europe as a result of the ETS (Morris 2012). Therefore, as well as being a useful exercise in comparing the emissions performance of different systems, decisions in the power sector will continue to have material implications for climate change.

## 3 Results

The carbon impact was found to vary substantially according to the LCT scenario and aspect investigated (for full results see the accompanying spreadsheet). Considering assets, the total quantity of emissions embodied was consistent across the different

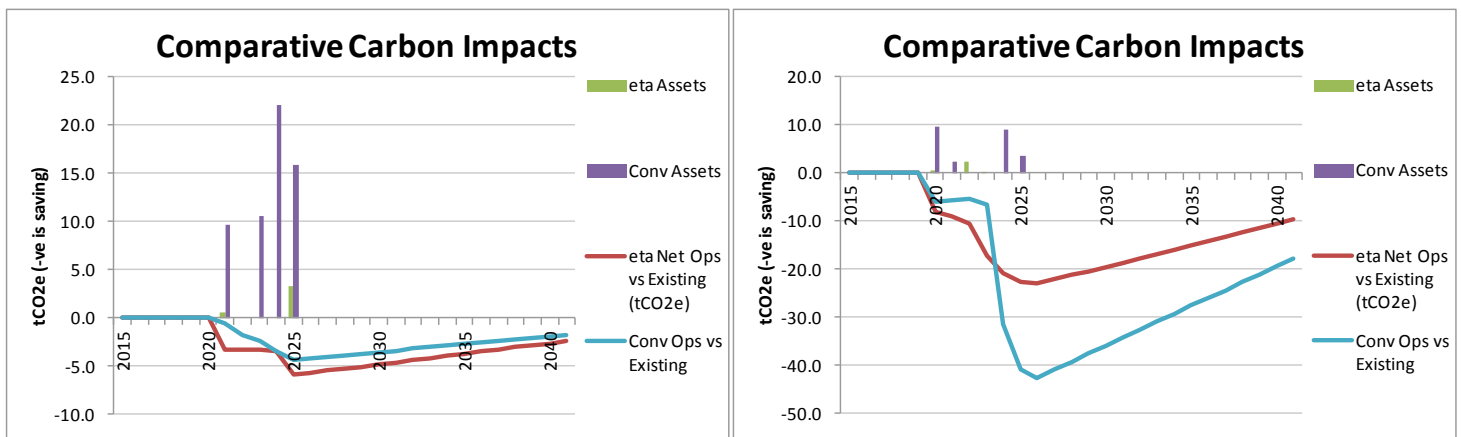
rates of uptake modelled. The total sum to 2040 for each scenario is shown below. It is clear that the *eta* Method only causes a small proportion of the impact of the conventional reinforcement.

Asset Carbon (tCO <sub>2</sub> e)				
Scenario	<i>eta</i>	Conv	Saving	Eta as % of Conv
Generation	3.9	58.3	54	6.7%
Demand	3.3	24.8	21	13.3%
WS3_S3	0.6	9.7	9.1	5.9%

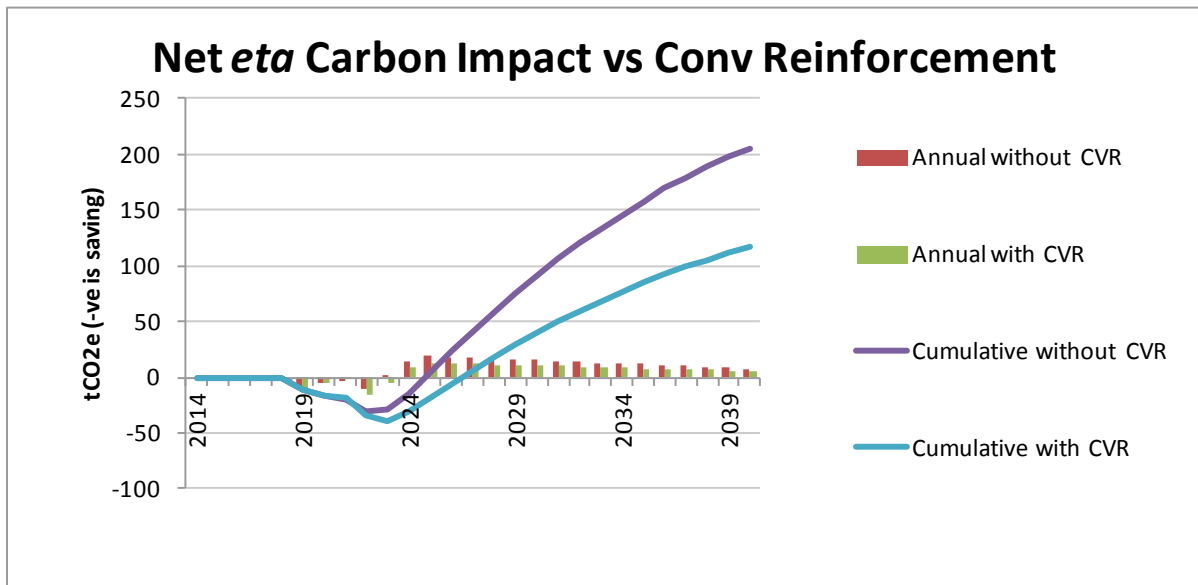
When operational and CVR carbon are also accounted for the time series makes a substantial difference to the total net carbon impact. In the Generation cluster scenario the *eta* Method realises between 66 and 321 tonnes of carbon savings over the 25 years considered (savings are reported as negative figures, increases relative to conventional reinforcement as positive).

	Carbon Impact (tCO <sub>2</sub> e)	
	without CVR	with CVR
<b>Generation</b>		
1 yr	-90	-321
10 yrs	-78	-213
25 yrs	-66	-89
<b>Demand</b>		
1 yr	432	282
10 yrs	206	117
25 yrs	-21	-44

The carbon impacts time profile for both the Generation and Demand clusters 10 year uptake scenarios are presented below for comparison (left and right respectively).



In the Demand clusters scenario, it is clearly seen that the conventional reinforcement provides a greater emissions reduction than the *eta* Method in terms of losses, and that over time this outweighs the savings on assets. The net break-even point, under this combination of parameters is between 2025 and 2027 dependent upon the inclusion of CVR benefits (see below). As a result, the Demand cluster scenarios realise between a net saving of 44 tCO<sub>2</sub>e and an increase of 432 tCO<sub>2</sub>e.



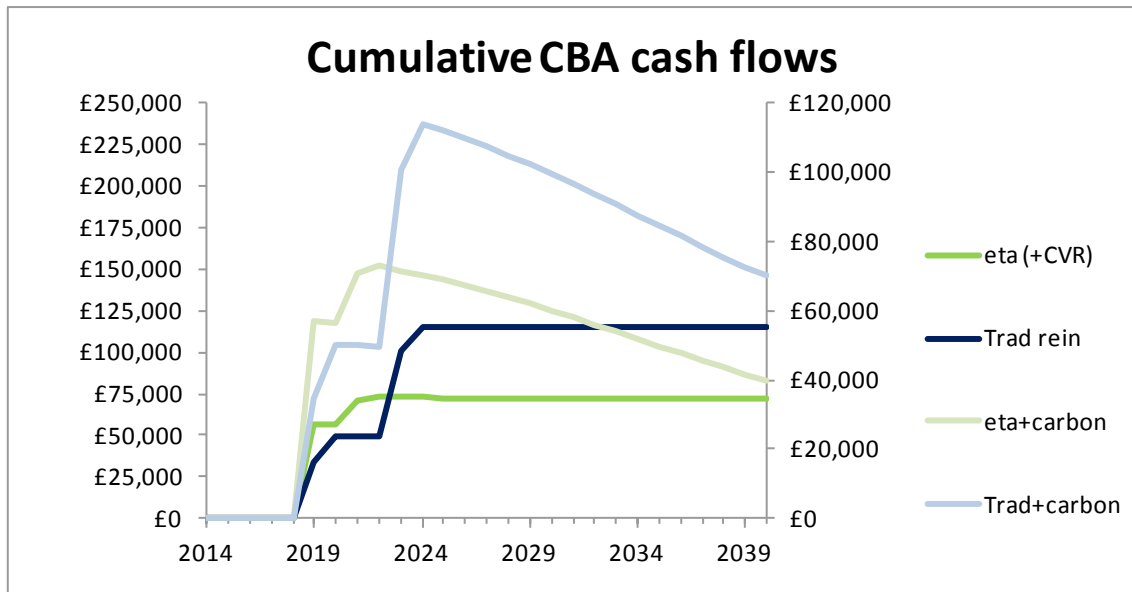
The WS3\_S3 scenario requires reinforcement only at the very end of the period under consideration, and only with very limited carbon consequences in all regards. Given the potential for substantial uncertainty over this time it is not discussed further.

### 3.1 Cost Benefit Analysis

The carbon impacts in each time period were converted to a monetary value using the DECC Central non-traded carbon shadow price (2012) for asset impacts and Ofgem RIIO-ED1 CBA template traded carbon prices for losses and CVR carbon. These were discounted at the social time preference rate (3.5%), summed to a net present value (NPV) and combined with the TNEI estimates of discounted cash flow.

Cost Benefit Analysis - NPV including cost of carbon						
	Eta	Traditional	Benefit	Eta+CVR	Traditional	Benefit
<b>Generation</b>						
<b>1 yr</b>	£114,989	£198,263	£83,274	£50,028	£198,263	£148,235
<b>10 yrs</b>	£64,463	£121,301	£56,839	£23,627	£121,301	£97,675
<b>25 yrs</b>	£27,633	£57,294	£29,662	£19,407	£57,294	£37,887
<b>Demand</b>						
<b>1 yr</b>	£95,336	£80,141	-£15,195	£53,269	£80,141	£26,873
<b>10 yrs</b>	£59,188	£47,186	-£12,002	£32,223	£47,186	£14,963
<b>25 yrs</b>	£24,717	£31,793	£7,076	£16,426	£31,793	£15,367

As can be seen above, there are two cases in which the *eta* Method does not realise a benefit (i.e. a reduction in the total cost of the intervention when summed and discounted) over the traditional reinforcement. It is interesting to note that in the case of the Demand cluster 1yr and 10yr scenarios with CVR included, even though there is a net carbon increase arising from *eta* (282 and 117 tCO<sub>2</sub>e respectively), the CBA still remains favourable due to the relative prices of carbon and the assets and the timing of the cash flow. The figure below describes the cumulative cash flow in the case of the Demand clusters (10yr) scenario. This can be compared to the cumulative carbon impact figure above to illustrate the positive CBA benefit despite net carbon impact.



### 3.2 ENWL and GB Scale

	Asset Carbon tCO <sub>2</sub> e	Total Carbon tCO <sub>2</sub> e
ENW Generation	532,243	2,007,452
ENW Demand	210,166	- 1,192,403
GB Generation	7,066,639	26,011,844
GB Demand	2,790,391	- 16,256,270

When multiplied to Electricity North West and GB wide scale there are substantial potential carbon savings but also the potential for increased losses to outweigh these versus a programme of traditional reinforcement. This is predominantly a result of high losses on the network in all circumstances should a rapid growth in consumer demand due to LCTs be realised. The plausibility of such circumstances and the financial acceptability of a programme of traditional reinforcement is, however, questionable. Further research during the *eta* Project would seek to identify the particular circumstances under which *eta* Method may not realise net carbon benefits.

## 4 References

Hawkes, A.D., 2010. Estimating marginal CO<sub>2</sub> emissions rates for national electricity systems. *Energy Policy*, 38(10), pp.5977-5987.

Morris, D., 2012. *Losing the Lead. The 2012 Environmental Outlook for the EU ETS*, [http://www.sandbag.org.uk/site\\_media/pdfs/reports/Losing\\_the\\_lead\\_modified\\_3.8.2012.pdf](http://www.sandbag.org.uk/site_media/pdfs/reports/Losing_the_lead_modified_3.8.2012.pdf)

## Appendix I: Indicative Customer Engagement Plan

### Executive summary

This indicative Customer Engagement Plan for *eta* reinforces our commitment to ensure best practice in engagement and customer communication for our four distinct customer groups:

1. Customers in the Trial areas;
2. Customers on the Trial networks who will experience planned interruptions for the installation of the network equipment;
3. Customers on the Trial networks who may receive short duration interruptions; and
4. Customers on the Trial networks who will participate in the customer **focus group** surveys.

We will establish our customer engagement strategy through feedback gained at Engaged Customer Panel sessions. The customer engagement will be launched with a general awareness campaign for directly and indirectly affected customers and the wider community. This will deliver key messages regarding Project objectives such as:

- The role and objectives of *eta* in facilitating the transition to a low carbon economy;
- *eta* and its potential benefits to the customer in the short and long term;
- The *eta* Trial areas;
- How a potential customer can participate in *eta* by a **customer focus group** survey;
- Underline the message that *eta* is a Project which can be applied with minimal interruption to their supply or no home visits taking place.

We will ensure that customers are able to inform themselves of the Project, raise queries and provide feedback about *eta* in a manner that is convenient to them. *eta* will achieve this throughout the Project life via a number of traditional and social communication channels, for example:

- Traditional: *eta* website, e-mail, telephone and post; and
- Social Media Communication: Twitter, Linked-In, Facebook.

Impact Research will manage the recruitment of participants and delivery of surveys for the Trial.

As we receive feedback from our customers, stakeholders and Partners we may need to revise our plans going forward. The *eta* Project will share all our customer communications materials, findings and consult Ofgem in advance of any significant changes from our original approach.

### Background

As GB moves to a low carbon future, electricity demand and the level of distributed low carbon generation is expected to increase significantly. The impact of this decarbonisation pathway on the GB electricity networks presents a number of key challenges which have potential to necessitate expensive capital investments.

Active customer participation is an integral part of *eta* and will form an important part of the learning and development for future low carbon programmes. Our engagement with customers will be designed to promote a positive customer experience throughout *eta*. We will therefore take all practicable steps to ensure that customers' best interests remain a priority at all times.

### Scope of *eta* Project

Through the application of novel solutions, the *eta* Project aims to introduce LV network control and visibility and co-ordinate network configuration and voltage optimisation across HV and LV circuits. This will be achieved via innovative equipment, dynamic voltage control and network reconfiguration methodologies which will deliver short, medium and longer term benefits for the customers of GB Distribution Network Operators.

The *eta* Method will be trialed on 5 Primary substations across ENWL's network, with a reach of 45 000 customers. *eta* will run for four years from mobilisation in January 2014 to close down in December 2017 with the Trial and customer survey element being undertaken across two full years beginning in October 2015.

### Customer Strategy and Customer Relations

#### Communications Strategy

*eta* will require targeted communications with all four separate groups of customers outlined above. The underlying communications strategy will be to:

- Launch a targeted awareness campaign to build on existing customer relationships in each of the customer segments;
- Engage with these customers on an on-going basis throughout the Project to ensure that the customer experience remains a positive one;
- Consider the needs of any vulnerable customers, identified on the Priority Services Register (PSR) affected by the Project; and

- Consider the needs of customers during Planned Supply Interruptions and look to mitigate impacts.

Electricity North West understands that without the support and buy-in of our customers, the *eta* Project will not succeed, and for this reason ensuring that the customer journey is a good experience is essential for the delivery of a successful Project.

## Customer Relations

Several communication channels will be available for customers, Partners and stakeholders who require further information about the *eta* Project.

### *eta website and social media*

Details will be available on the *eta* website at [www.enwl.co.uk/eta](http://www.enwl.co.uk/eta) providing general information on the Project and Trial networks and circuits, Frequently Asked Questions (FAQ) and contact details. Queries can be raised on the website using an online enquiry service. The Project website will be the hub for all information relating to the *eta* Project and will be supplemented online by Social Media activity. This could include the establishment of *eta* community groups on sites such as Twitter or Facebook.

## Enquiries

Customers can ask questions or raise queries related to the using the following channels:

### *Telephone*

Electricity North West operates a contact service that is continuously staffed and can be contacted 24 hours a day on 0800 195 4141. There will be a specific Interactive Voice Response (IVR) option available for all low carbon enquiries.

### *SMS*

For customers who wish to receive a call back service, an SMS can be sent quoting "*eta*". This will ensure an Electricity North West representative will call the customer back as soon as possible.

### *Written correspondence*

The *eta* Project team will handle written enquiries from customers and stakeholders. Customers can contact the Project Team by post at the following address:

*eta* Project Team  
Electricity North West Limited  
Frederick Road  
Salford  
M6 6QH

Alternatively, customers can contact the Project team at the following email address: [futurenetworks@enwl.co.uk](mailto:futurenetworks@enwl.co.uk) for queries or further information.

## Customer Engagement

Customer engagement includes all aspects of customers' involvement with the *eta* Project, such as:

- Establishing which customers need to be engaged;
- Developing and implementing engagement plans;
- Planning customer selection and approach for **focus group** survey participation;
- Bringing customers into the Project;
- Keeping customers engaged in the Project; **and**
- Managing customers' issues, enquiries and complaints.

## *eta* Customer Groups

### 1. Customers in the Trial areas

Whilst there is no active involvement from the wider community, we will launch a targeted awareness campaign with customers, stakeholders and the wider community. Our communications materials will outline the scope, size and areas of the distribution network included in *eta* as well as outlining the objectives of the Trial within the context of the UK's low carbon agenda. Customers will be provided with general information about *eta* and how to participate in the Trial. The materials will also advise customers that installation of enabling technology may require a planned supply interruption.

We will establish how to engage customers in the Trial areas and the materials for engagement through feedback from our Engaged Customer Panel. The engagement may be achieved using a range of multi-media approaches with the Electricity North West website containing information about the Project and a dedicated *eta* website to be established in due course.



We will form an Engaged Customer Panel to help us formulate effective communication plans to provide clear information for customers. The Panel will be made up of an appropriate cross section of customer segments. Potential types of engagement include:

- We will publish trade magazine articles to publicise *eta*, outlining the aim and objectives of the Trial within the context of the low carbon agenda;
- Form online communities in forums such as LinkedIn;
- We will produce leaflets which will be made available to all customers outlining the scope, size and areas of the distribution network included in *eta* and how to participate in the Trial;
- Information about *eta* and our other low carbon activities with relevant communications materials will be published initially on the Electricity North West website and subsequently on the *eta* website;
- We will contact electricity suppliers, advising them of the nature of the Trial and details of the timing and nature of communications with customers;
- Internal team briefings will be held throughout the Project to ensure that *eta* objectives are fully understood and lessons learned are shared across the wider Electricity North West community. Regular updates will also be included in the internal Company magazine, Newswire.

## **2. Customers on the Trial networks who will experience planned interruptions for the installation of the network equipment**

Customers in this category will be affected by the Planned Supply Interruptions associated with installation of the enabling technology. Electricity North West will manage these impacts by standard written notification informing these customers of a planned supply interruption, in accordance with standard procedures. We will use our Priority Services Register to identify vulnerable customers with additional requirements and make telephone contact with them. This proactive approach will enable us to maintain their safety and security requirements throughout the planned supply interruption.

## **3. Customers on the Trial networks who may receive short duration interruptions**

Due to the application of interconnected configurations to LV networks, there is a possibility that any normally occurring fault on an LV feeder will lead to other customers in an *eta* Trial area being affected. In this instance, the network will be reconfigured remotely and those customers will have their supply restored within three minutes. Using historical fault data, this number has been calculated at 240. Our engagement actions will inform:

- All customers within the Trial locations about the theoretical increase in short duration interruptions (SDI) through the Project awareness communication materials; and
- The Customer Contact Centre on *eta* Trial areas, so that any subsequent customer queries can be answered.

## **4. Customers on the Trial networks who will participate in the customer surveys**

Understanding whether the customer is affected during the Trial is crucial to the viability of the *eta* solution. Therefore we will seek customers inside the Trial area to participate in customer **focus group** surveys **towards the end of the** Trial period. The aim of **this** is to answer the question do customers within the *eta* Trial areas perceive any changes in their electricity supply.

Other LCN Fund Projects have found that letter drops generate low interest whilst door knocking and community led programmes can deliver much higher participation rates. Once the geographic spread of the Trial sites is known, *eta* will define and detail the engagement approach.

## **Our Partners**

Electricity North West has selected Partners with consideration for their strong credentials in the area of customer engagement and approach to customer relations. All of our Partners are represented on the *eta* Project Steering Group which forms part of the governance for the Project. These Partners are:

- Siemens;
- Kelvatek;
- Impact Research.

For the purposes of *eta*, the Project Partners will adhere to the key principles outlined below:

- Project Partners responsible for any form of customer contact will ensure that their codes of practice include guidance on ensuring that customer contact is appropriate. This includes making clear to customers that the contact relates to the *eta* Project. As a minimum, contact will involve clear information on the *eta* Trial they are participating in;
- Clear information on the aims and objectives of the contact;
- Information on data protection;

- Project Partners with access to customer data gathered for *eta* will sign an agreement to ensure that this data is not used for purposes other than in relation to the *eta* Project (see also *eta* Data Privacy Statement). Our Data Security Manager takes responsibility for all aspects of data privacy within the *eta* Project;
- Where Project Partners have relationships with customers participating in *eta* that are outside the scope of the Project, the Partners will make it clear in customer communications whether their communication relates to *eta* or the wider relationship;
- Any customer considering participation in *eta* will receive clear information about what the Trial will involve, together with details both of who to contact if they have queries or complaints, and who will have access to their data;
- Any customer agreeing to participate in *eta* will receive sufficient information to enable them to understand what will be expected of them and the purpose and scope of the programme;
- When collecting data, the Project Partners will be transparent about why they are collecting the data and how it will be used, stored and accessed.

### **Feedback and Review**

This Customer Engagement Plan is a starting point for our communication with customers throughout the *eta* Project from January 2014 to December 2017. All *eta* Partners will adhere to the Plan and the basic principles outlined. However, there will be a need to review the plan on an on-going basis to reflect feedback and lessons learned as we progress with the *eta* journey.

*eta* will develop a series of communication materials throughout the Project which will be published on the *eta* website and made available to customers. We will submit all our customer communications materials to Ofgem allowing Ofgem to comment on these documents if they wish.

### **Customers**

Throughout the *eta* Project and in all the activities which involve engagement with our customers we will seek feedback on the customer experiences. We will use a range of contact methods, as appropriate, including postal form, telephone and web based survey form to obtain feedback from customers. We will use the results of the feedback to amend our processes.

### **DNOs, Project Partners and Interested Parties**

We will work with Partners to disseminate the learning points from the Project, and seek feedback from interested parties.

We will provide regular updates on the *eta* website and interested parties will be able to register for a newsletter which will be produced on a periodic basis. We will share our learning experience of the *eta* Project outcome with interested parties, including other DNOs and academic institutions throughout the Project.

### **Stakeholder consultation**

We have consulted all our Partners and relevant departments in Electricity North West to produce this engagement plan. Throughout the bid preparation process we worked to engage a number of groups to gauge support for and understanding of the *eta* Project. These include the Future Networks Steering Group.

### **Project Steering Group**

The Project Steering Group will review and guide the Project's activities, deliverables and objectives and set the strategic direction. The Project will be subject to the robust governance procedures, employed by Electricity North West, from Project mobilisation until Project closure.

## Infrastructure and Cities

# SIEMENS

Steve Cox, Head of Future Networks

Date 31 July 2013

### Electricity North West: Low Carbon Networks, Tier 2 - Eta Project

Steve,

Following your competitive selection process Siemens is delighted to have been selected as the partner of Electricity North West to provide the optimisation software for the eta Project.

The eta method and project concept continues in the theme of Electricity North West previous successful Tier 2 submissions, C2C and CLASS, by leveraging value from existing network assets. The Eta method builds upon learning derived from IFI and Tier 1 Projects and goes further than any previous LCNF Project in addressing the real challenges at the Low Voltage part of the network.

Whilst the Eta method is ambitious, it addresses the challenge of providing dynamic and responsive low voltage networks at the customer level where the impact of low carbon technologies is greatest. The optimisation of voltage to this granular level provides significantly greater network capacity, to connect additional load and generation; for the distribution network operator, the application of this method provides a compelling business case to apply Eta as the first network intervention strategy.

Siemens has experience of working with most of the UK Distribution Network Operators in the Low Carbon Network Fund and has proven technology and products, including the optimisation software that will be deployed in the Eta Project. The important learning and excitement in the Eta method, is how it is applied with other innovative low voltage technologies (i.e. WEEZAP) as part of an automated LV management system.

Siemens has the local experience and global technologies to deliver the project and is committed to help Electricity North West and the other project partners with the learning and dissemination programme.

Siemens continually seek engagement in thought leading projects and is proud to be part of Eta with Electricity North West.

Yours sincerely,



Kevin  
Tutton  
**UK Divisional Lead – Smart Grid  
Division**

Infrastructure and Cities Sector

Registered No 631825  
Registered Office: Faraday House, Sir William Siemens Square, Frimley, Camberley GU16 8QD

SCF DL2008-09

Page 1 of 1

26<sup>th</sup> July, 2013.

I am writing to express the support of Kelvatek for the eta project. The eta project is particularly innovative as not only does it address the issue of LV network automation and voltage control, but does so in co-ordination with the HV network. ENWL are to be commended on their proposal to explore this issue and in planning their project such that there are immediate benefits for the distribution network and its customers in addition to facilitating more electrification of energy use. Once proven and understood, the eta method has potential application across all GB distribution networks.

We have been working with Electricity North West (ENWL) for many years in various capacities. The BIDOYNG, REZAP Modular and WEEZAP were conceived and designed through collaboration with ENWL.

Kelvatek is fully committed to assisting ENWL with demonstration of the eta method. We have developed the WEEZAP LV Automation Circuit Breaker in support of the eta project, which we feel will have significant advantages for ENWL's network performance, especially as more LCTs are connected to the network.

At Kelvatek we feel that it is imperative for leading technology providers to work in collaboration with utilities in order that the main issues are thoroughly understood and solved. Our vision is to work in collaboration with DNOs and other technology providers to develop and deploy real intelligence at the key junctures in the network, thereby helping the utilities meet the challenges of the coming decades.

Yours sincerely,



Simon Brooke  
Electricity North West Limited  
304 Bridgewater Place  
Birchwood Park  
Warrington  
WA3 6XG

Impact Research Ltd.  
3 The Quintet  
Walton-On-Thames  
Surrey  
KT12 2TZ

25<sup>th</sup> July, 2013

**Ref: eta  
Project**

Dear  
Simon,

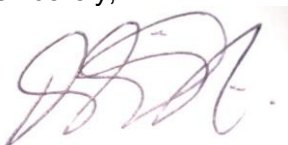
Impact Research is very pleased to be part of the Consortium of Partners providing customer engagement insight for the eta project to support the UK's transition to a low carbon economy. The eta project is a creative initiative and we are delighted to play a significant part in assessing domestic customers during the trial period.

Impact Research's main role ranges from recruiting and interviewing customers for the trial through to reporting on the trial findings. Impact Research recognises the importance of its involvement and will be fully committed to the success of eta. Impact Research has experience working on other customer engagement projects related to Low Carbon initiatives covering qualitative and quantitative research. Ensuring a strong and robust method to provide reliable results is central to Impact Research's approach. Additional extensive experience in a variety of other research projects within utilities and other sectors will support the expertise demonstrated in this project.

Low Carbon initiatives such as eta are vital in ensuring the UK achieves its carbon emissions reductions target and Impact Research is proud of being part of this.

We are delighted to have been invited by ENW to be part of the Consortium of Partners, and I have full confidence the team will deliver a successful, high quality and robust project.

Yours  
sincerely,



Darryl  
Swift  
Manager  
Director

Impact Research Ltd, 3 The Quintet, Walton-On-Thames, Surrey, KT12 2TZ  
Registered in England No 7245397  
VAT No 990 0342 31

Simon Brooke

Electricity North West Limited

Date: 29 July 2013

**Re: Letter of Support from The University of Manchester for ENWL *eta* Project**

Dear Simon,


I am pleased to write a supporting letter for the Electricity North West Limited (ENWL) *eta* Project.

I appreciate that regional electricity companies, such as, ENWL, are being encouraged by Ofgem to facilitate the transition of today's distribution network to a low carbon one. This will encourage the installation of significant renewable energy resources and allow the connection of new forms of demand, such as electric vehicles and heat pumps. The intermittency of renewable energy production and expected variations in demand requires radical solutions such as those proposed by the *eta* Project. Indeed, the use of coordinated HV-LV control of voltage regulation devices as well as HV-LV network reconfiguration to allow higher penetrations of low carbon technologies and to also reduce losses and energy consumption is highly innovative. I believe the *eta* Project provides an excellent opportunity to demonstrate how HV and LV networks can become more efficient and how traditional reinforcements can be deferred in the short term by the novel use of voltage control and reconfiguration devices.

The *eta* Project will build upon the excellent research links that ENWL has already established with the world renowned Electrical Energy and Power System (EEPS) group at The University of Manchester. The EEPS group consists of 13 full-time academic staff and over 90 researchers, PhD students and academic visitors. It has core expertise covering transmission and distribution networks planning, monitoring, control, protection, HV technologies and substation automation. Facilities include the largest HV research facilities in a UK university and the recently refurbished control, protection and automation laboratories.

The University of Manchester is strongly committed to the success of the *eta* Project and is dedicated to providing appropriate academic staff expertise as indicated in the proposal submitted by the EEPS group. The School of Electrical Engineering will where possible provide extra resources as appropriate, such as PhD scholarships and summer internships, to maximise the *eta* Project outcomes.

Yours sincerely,



Professor Anthony Brown  
Head of School

Simon Brooke  
Electricity North West Limited  
304 Bridgewater Place Birchwood Park Warrington  
WA3 6XG



26<sup>th</sup> July, 2013

**Ref: eta Project**

Dear Simon,

Wigan and Leigh Housing is delighted to be part of the consortium of Partners and supporters of the eta project, further tackling carbon reduction and fuel poverty which are key objectives for our organisation.

Wigan and Leigh Housing manage 22,600 dwellings, which is the biggest social housing stock in Greater Manchester, and see climate change as one of the greatest threats to our region and the world.

The government and the Association of Greater Manchester Authorities (AGMA) have set challenging targets to reduce carbon emissions including increasing energy efficiency of our housing stock and to move away from our reliance on fossil fuels to low carbon alternatives. A provisional objective to start switching dwellings from gas to low carbon heat sources by 2020 means this project is both strategically relevant and timely to our asset plans.

Following the announcement of the domestic RHI for social landlords and the inevitable increase of electricity demand we feel this project shows both commitment and early intervention to the challenges network operators and organisations like ourselves will face in the future as we move to alternative technologies.

With a track record of successful partnership working with ENW through our PV installation programme and more recently the early phases of a highly innovative Smart Communities project, we relish the opportunity to be part of the Consortium of Partners, and I am fully confident the team will deliver a successful, high quality project.

Yours sincerely,

A handwritten signature in blue ink, appearing to read 'M Roberts', is placed over a light blue rectangular background.

**Matt Roberts**  
**Director of Asset Management and Development**

Wigan and Leigh Housing Company Ltd, Unity House, Westwood Park Drive, Wigan, WN3 4HE.

Web site – [www.walh.co.uk](http://www.walh.co.uk), E-mail address – [enquiries@walh.co.uk](mailto:enquiries@walh.co.uk)

Wigan and Leigh Housing Company Limited is limited by guarantee and controlled by Wigan Borough Council. Registered in England and Wales, No. 4395696. Registered office address: Unity House, Westwood Park Drive, Wigan WN3 4HE.

5<sup>th</sup> August 2013

Simon Brooke  
Electricity North West Limited  
304 Bridgewater Place  
Birchwood  
Warrington  
WA3 6XG

Dear Simon,

**Re: Letter of Support from Queen's University for the ENWL *eta* Project.**

I am pleased to write a letter of support for the Electricity North West Limited (ENWL) *eta* project.

Regional Electricity Companies, such as ENWL, are being encouraged by OFGEM to facilitate the transition of today's distribution networks to a future Low Carbon Network (LCN). LCNs will facilitate the installation of significant renewable energy resources and allow the connection of new forms of demand, such as electric vehicles and heat pumps. The intermittency of renewable generation and these new forms of demand call for radical solutions, such as proposed in the *eta* project which seeks to perform real-time LV network management to enhance electricity delivery so that it will be both more efficient and flexible and have a reduced carbon impact. I believe the *eta* project provides a real opportunity to demonstrate how dynamic LV network reconfiguration and novel voltage control techniques can be applied to maximise the use of existing LV network assets and at the same time enhance supply resilience and reduce electricity costs to customers.

The *eta* project builds upon excellent existing links between ENWL and the University of Manchester. The School of Electronics, Electrical Engineering and Computer Science through its Energy, Power and Intelligent Control (EPIC) Research Cluster, which consists of 11 full-time academic staff and over 40 researchers, PhD students and academic visitors, is delighted to further its existing collaboration with the University of Manchester by joining the *eta* consortium.

Queen's University is fully committed to the success of the *eta* project and will provide appropriate academic support as indicated in the *eta* proposal. The School of Electronics, Electrical Engineering and Computer Science will where possible, provide extra resources as appropriate, such as PhD scholarships, to maximise the *eta* project outcomes.

Yours sincerely,



Professor N.S. Scott, FBCS, FIET, SMIEEE  
Head of School: Electronics, Electrical Engineering and Computer Science



## Appendix K

## References

1. UK Photovoltaic Solar Energy Road Map:  
<https://connect.innovateuk.org/documents/3248377/3710301/UK+Photovoltaic+Solar+Energy+Road+Map.pdf/aea4fd4f-d2f7-4d28-b1d3-4ca16a334003>
2. Fuel Poverty Advisory Group (for England) Tenth Annual Report 2011-2012 (December 2012): [www.gov.uk/government/publications/fuel-poverty-advisory-group-tenth-annual-report-2011](http://www.gov.uk/government/publications/fuel-poverty-advisory-group-tenth-annual-report-2011)
3. Electricity North West Limited Carbon Footprint Report: [www.enwl.co.uk/docs/about-us/carbon-footprint-report.pdf](http://www.enwl.co.uk/docs/about-us/carbon-footprint-report.pdf)
4. Electricity North West Limited Capacity to Customers C2C Project: [www.enwl.co.uk/c2c](http://www.enwl.co.uk/c2c)
5. Electricity North West Limited CLASS Project: [www.enwl.co.uk/class](http://www.enwl.co.uk/class)
6. Fuses used in LV fuse ways and link boxes of distribution networks are classified as Class J fuses and are commonly referred to as J type fuses.
7. London Economics Report for Ofgem and DECC on The Value of Loss Load (VoLL) for Electricity in Great Britain (July 2013).
8. First Tier LCN Fund projects LV Network Solutions:  
[www.ofgem.gov.uk/Networks/ElecDist/lcnf/ftp/enwl/Documents1/ENWL003\\_LV%20Network%20SolutionsLocked.pdf](http://www.ofgem.gov.uk/Networks/ElecDist/lcnf/ftp/enwl/Documents1/ENWL003_LV%20Network%20SolutionsLocked.pdf)
9. First Tier LCN Fund Project Voltage Management at LV Busbars:  
[www.enwl.co.uk/docs/about-us/lcnf\\_tier1trial\\_voltage-management-at-low-voltage-busbars.pdf](http://www.enwl.co.uk/docs/about-us/lcnf_tier1trial_voltage-management-at-low-voltage-busbars.pdf)
10. LoVIA:  
[www.ofgem.gov.uk/Networks/ElecDist/lcnf/ftp/enwl/Documents1/ENWxxxx%20Tier%201%20LoVIA.pdf](http://www.ofgem.gov.uk/Networks/ElecDist/lcnf/ftp/enwl/Documents1/ENWxxxx%20Tier%201%20LoVIA.pdf)

## **List of Changes**

This section documents the changes from the original *eta* Full Submission version ENWLT205/01, submitted on 9 August 2012, to this version, ENWLT205/02.

The table below details each change and the reason for the change.

All additions to the *eta* Full Submission and Appendices documents are easily identifiable as they are coloured red. The exceptions to this rule are the opening sentence in Full Submission Sections 1.3, 2.1, 3, 4, 5, 6 & 8 as red is used to emphasise a key messages; the negative numbers in Table 3.2 in the Full Submission; the negative numbers in tables on pages 74, 82 and 83; and Figures 2.2, 3.5 & 6.1 in Full Submission.

<b>Questions and Answer Process</b>			
<b>Location</b>	<b>Change</b>	<b>Reason</b>	<b>Generated</b>
Section 1.3, page 1	Amend customer survey engagement.	Value for money	Expert Panel
Section 1.4.1, 1.4.4 & 1.4.5 page 1	Amend project cost and contribution to reflect changes to customer survey scope, contribution from Siemens and reduced customer costs	Clarification	Expert Panel
Section 1.6, page 2	Addition of 'dissemination' to Partner involvement descriptions.	Clarification	n/a
Section 2.1, page 4	Reveal part of sentence covered by Figure 2.1.	Clarification	n/a
Section 2.3, page 10	Clarify evaluation of individual customer's savings.	Clarification	Expert Panel
Section 2.3, page 10	Amend customer survey engagement.	Value for money	Expert Panel
Section 2.4, page 12	Reduce LCN Funding request.	Value for Money	Expert Panel
Section 3, page 13	Clarifying the scenario.	Clarification	n/a
Section 3, page 14	Remove full stop after 6.7%.	Clarification	n/a
Section 3, Figures 3.3 & 3.4, page 15	Clarifying discount rate applied in charts.	Clarification	n/a
Section 3, Figure 3.5, page 15	Clarifying percentages.	Clarification	n/a
Section 3, page 17	Replace and renumber Figure 3.4 (now Figure 3.6) with graph showing updated contribution	Clarification	n/a
Section 3, page 18	Replace and re-number Figure 3.5 (now Figure 3.7) with chart showing updated contribution, reduced University costs and customer survey contingency amendment.	Clarification	n/a
Section 3, page 18 & 19 "Costs and Assumptions"	Include new Figures 3.8 – 3.11 showing <i>eta</i> costs breakdown by workstream and payments to detail each component of the budget.	Clarification	Expert Panel

Section 3, Page 19	New contingency amount and updated Electricity North West contribution.	Value for money	Expert Panel
Section 4a, page 22 "Method cost and Base Case costs"	Refer to additional appendix detailing projected future cost savings assumptions.	Clarification	Expert Panel
Section 4b, page 24	Update Table 4.1 including universities' Project resource committed to <i>eta</i> .	Value for money	ENWT2Q22
Section 4d, page 27	Detail Siemens' additional roles on project.	Value for money	Expert Panel
Section 4d, page 27	Amend customer survey engagement.	Value for money	Expert Panel
Section 5, page 30	Confirm dissemination events at The Crystal.	Value for money	Expert Panel
Section 5, Table 5.1, page 32	Confirm additional deliverable, "Implementation strategy for other NMS users" and amended customer experience report.	Value for money	Expert Panel
Section 6, page 36	New contingency amount.	Value for money	Expert Panel
Section 6, page 36	Amend customer survey engagement.	Value for money	Expert Panel
Section 6, page 37 & 38	Update Figure 6.3 and text for change in customer survey engagement.	Value for money	Expert Panel
Section 8, page 42	Confirm no customer impact of operating at lower end of statutory voltage range.	Clarification	Expert Panel
Section 8, page 42 & 43	Confirm no customer impact from use of capacitors to manage voltage.	Clarification	Expert Panel
Section 8, pages 43 & 44	Amend text for change in customer survey engagement.	Value for money	Expert Panel
Section 9, page 44	Amend SDRCs, 9.3.2, 9.3.3 and 9.3.5, for change in customer survey engagement.	Value for money	Expert Panel
Section 9, page 45	Additional SDRC, 9.4.6, within Research Workstream for "Optimisation Implementation Strategy".	Value for money	Expert Panel
Section 10, page 47	Update Appendix G to include table of cost saving assumptions	Clarification	Expert Panel
Appendix C, page 57	Updated Organogram highlighting partners involvement in Project Steering Group and Workstreams.	Clarification	Expert Panel
Appendix D, page 58	Detail Siemens' additional contribution and roles on project.	Value for money	Expert Panel
Appendix D, page 58	Amend description of Impact Research's contribution.	Value for money	Expert Panel
Appendix D, page 58	Amend role description for Queen's University Belfast.	Value for money	Expert Panel
Appendix E, page 63	Remove risks for change in customer survey engagement.	Value for money	Expert Panel

Appendix F, page 65 to 68	Amend Project Plan for change in customer survey engagement and SDRC addition/changes	Value for money	Expert Panel
Appendix G1, page 74	Updated table clarifying discount rate.	Clarification	n/a
Appendix G2, page 79	Addition of cost reduction assumptions clarification table	Value for money	Expert Panel
Appendix I, pages 85,86 & 87	Amend for change in customer survey engagement.	Value for money	Expert Panel
eta Full Submission spreadsheet	Amend Customer Engagement and Survey costs for change in customer survey engagement and University costs	Value for money	Expert Panel
eta Full Submission spreadsheet	Add Siemens' additional contribution.	Value for money	Expert Panel