

Connection Charging Methodology and Statement

Effective from 1 April 2007

Version 1.1

Contents

Part 1 Introduction and Methodology	1
1 About this statement.....	2
2 Introduction	4
2.1 Licence Condition Objectives.....	4
3 Charging Methodology	5
3.1 Costs Included in the Connection Charge	5
3.2 The Electricity (Connection Charges) Regulations 2002	5
3.3 Network Characteristics	5
3.4 Minimum Design	5
3.5 Reinforcement Apportionment Rules.....	6
3.6 Security Reinforcement.....	6
3.7 Fault Level Reinforcement.....	7
3.8 Speculative Connection Enquiries	7
3.9 Temporary Connections.....	7
Part 2 Connection Charges and Your Options.....	8
4 Connection charges and your options.....	9
4.1 Purpose of this document	9
4.2 Persons entitled to apply for connection	10
4.3 Procedure for obtaining a connection	10
5 Customer Quotations.....	11
5.1 Initial request from customer - information required	11
5.2 What to expect at the quotation stage	11
5.3 Payment policy.....	12
5.4 What to expect after accepting a quotation.....	13
6 Non-contestable work to be carried out by NEDL.....	14
6.1 Connection work	14
6.2 Non-contestable work	14
6.3 Network assessment and design fees	14
6.4 Requesting a connection from us	15
7 Work that NEDL or your contractor may do	16
7.1 Contestable works	16
7.2 Your options.....	18
7.3 Points to note regarding adoption of competitive works	18
8 Other Connection Activities	20
8.1 Unmetered connections.....	20
8.2 Disconnection Services.....	21
8.3 Small generators connected to the low voltage network.....	22
9 Schedules, Tables of Charges and Examples	24
9.1 Domestic tariff support allowance	24
9.2 Indicative charges	24
9.3 Examples of typical connections.....	29

10	Disputes	43
10.1	Dispute and determination procedure.....	43
11	General	44
11.1	Terms and conditions	44
11.2	Operation and maintenance costs.....	45
11.3	Connection charges.....	45
11.4	Connection agreements	45
11.5	Reinforcement	45
11.6	High cost projects	46
11.7	Enhanced connections	46
11.8	Interaction with other customers.....	47
11.9	Expenditure before need	47
11.10	Connections for generators	47
11.11	Metering, telemetry and data services.....	47
12	Glossary of terms	48
13	Other publications	50
14	Version Control	51

Part 1 Introduction and Methodology

1 About this statement

CE Electric UK Funding Company (CE) is the UK parent company of Northern Electric Distribution Ltd (NEDL). NEDL is a licensed distribution business covering the area shown below.



This statement has been prepared by NEDL in accordance with the requirements of Condition 4B of its Electricity Distribution Licence ("the Licence") issued under the Electricity Act 1989, as amended by the Utilities Act 2000 ("the Act").

Where a person requires a connection to obtain a supply of electricity pursuant to section 16(1) of the Act, the provisions of this statement are without prejudice to the provisions of sections 16 to 24 of the Act. Words and expressions used in this statement have the definitions given to them in the Act and shall be construed accordingly.

This is one of a suite of three documents that describe charges for connection to and use of NEDL's system and the methodologies behind them.

The Gas and Electricity Markets Authority ("the Authority") have approved the connections charging methodology and the form of the connections charging statement.

The other documents that are available are:

- NEDL's Statement of Use of System Charges; and
- NEDL's Use of System Charging Methodology.

These are available on our website at www.ce-electricuk.com

Details of charges for metering and data services can be found in NEDL's Statement of Metering and Data Services Charges in accordance with Licence condition 36B.

NEDL does not charge for providing copies of the statement where they are downloaded, in PDF format, from the NEDL website. Where paper copies are required, a fee of £5 may, at the discretion of NEDL, be payable for each copy provided.

Enquiries with regard to the application of this statement should be made to:

Chris Allanson
Connection Policy Manager
98 Aketon Road
Castleford
WF10 5DS

e-mail:- chris.allanson@ce-electricuk.com

2 Introduction

2.1 Licence Condition Objectives

The Licence requires that NEDL must review the connection charging methodology at least once every year to ensure continuing achievement of the relevant objectives as outlined below.

The Connection Charging Methodology has the following objectives set out in Standard Licence Condition 4B:

- a) that compliance with the Connection Charging Methodology facilitates the discharge by the licensee of the obligations imposed on it under the Act and by the Licence;
- b) that compliance with the Connection Charging Methodology facilitates competition in the generation and supply of electricity, and does not restrict, distort or prevent competition in the transmission or distribution of electricity;
- c) that compliance with the Connection Charging Methodology results in charges which reflect, as far as reasonably practicable, the costs incurred by the licensee in its distribution business; and
- d) that, so far as is consistent with sub-paragraphs (a), (b) and (c), the Connection Charging Methodology, as far as is reasonably practicable, properly takes account of developments in the licensee's distribution business.

Following any review, NEDL must make such modifications (if any) to the Connection Methodology as may be necessary to better achieve the relevant objectives. However, before a modification can be made, a report must be issued to the Authority setting out the terms of the modification, how the modification better meets the relevant objectives and a timetable and date for implementation of the modification.

Unless the Authority has, within 28 days of receiving the licensee's report, given direction that the modification may not be made, or that it intends to consult interested parties on the matter, NEDL will make the modification to the Connection Charging Methodology.

In addition, with the approval of the Authority, NEDL may alter the form of the statement from time to time and also revise the statement such that the information set out is accurate in all material respects.

3 Charging Methodology

3.1 Costs Included in the Connection Charge

The costs of any assets required to connect a party to the existing network are chargeable in full within the Connection Charge. The costs may include those relating to extension works, e.g. new cables or overhead lines, along with a contribution to the costs associated with the reinforcement (if any) of the existing distribution network as determined by the apportionment rules outlined in this section.

There may also be a requirement for other costs to be included within the connection charge, such as the additional costs incurred in facilitating connections to the Distribution System for Independent Connection Providers. In general, there will be no specific charges for ongoing operation and maintenance of the minimum connection assets. However, operational and maintenance charges may apply under certain circumstances, including where there are additional requirements specific to a particular connection which are above the normal level of assets required to be installed.

See section 11.2 for details of how operation, repair and maintenance charges are applied.

3.2 The Electricity (Connection Charges) Regulations 2002

As indicated in this statement, connection charges are based upon the costs of the assets installed for the benefit party seeking the connection. In certain circumstances, however, the party seeking the connection will be required to make a payment in respect of assets that are already installed and are to be used for the purpose of giving the supply to that party, this may include a payment in respect of previous reinforcement costs. The circumstances are laid down in detail in The Electricity (Connection Charges) Regulations 2002 and The Electricity (Connection Charges) (Amendment) Regulations 2002. A copy of these regulations can be found on the HMSO website @:

<http://www.hmso.gov.uk/cgi-bin/dialogserver.exe?DB=hmsso-new>

3.3 Network Characteristics

The work to be done and the connection charge payable will depend on the requirements of the party seeking the connection, on the condition of the distribution system at the point of connection, and on any other characteristics relevant to the connection. This will also include the effective capacity and voltage level of the relevant part of the system in relation to the requirements of the party seeking the connection.

NEDL reserves the right to specify the terms applicable in cases where the normal charging criteria may not apply following consultation with the applicant. Please refer to section 11 for examples of where the normal criteria and the apportionment rules may not apply.

3.4 Minimum Design

The costs to be recovered in the connection charge will be determined from the estimated costs of the minimum scheme which could be designed to meet the requirements of the connection and for the sole benefit of the party or parties being connected, consistent with sound engineering practices and NEDL's system design philosophy, and subject to the specifications and standard sizes of equipment used by NEDL.

NEDL will design the minimum network solution to allow the connection of the relevant party and to meet the Required Capacity. The Required Capacity means the design capacity of the Connection at the ownership boundary, as agreed between the Connecting party and the

Distributor, and laid down in the Connection Agreement. For multiple connections this may be after taking account of demand diversity and appropriate design standards. Capacity may be for either imports to or exports from our network and subject to variation in power factor.

Please see Table 6 and Table 8 in section 9.2 for indicative charges for design activities.

3.5 Reinforcement Apportionment Rules

The 25% rule for allocation of reinforcement costs has now been removed and replaced with a more proportionate method known as the Apportionment Rules. This means that connecting parties, both demand and generation, are required to contribute to reinforcement costs on a sliding scale basis.

The apportionment rules may not be applied under certain circumstances, including the circumstances outlined in sections 3.8, 3.9 and 11.

In the case of network reinforcement the existing assets will be removed and in some cases will be old or not reusable, but in other cases will have some residual value and we will retain this value on behalf of customers in general for future use on the network where appropriate.

The cost associated with reinforcement of existing distribution network assets will be split, with a share attributed to the connecting party based on their requirements as part of the Connection Charge and the remainder normally recovered through NEDL's use of system tariffs.

Reinforcement of the existing system (which for this purpose means works occasioned by the new or increased connection, but not for its sole use) will be charged based on the apportionment rules. Apportionment rules for reinforcement are split between a network security rule and a fault level rule. These rules apply to both demand and generation connections and apply to all distribution voltages and EHV. There may be interactions between the rules on more complex schemes. The rules will be applied in a consistent manner, which means the network security rule will apply to reinforcement works driven by compliance with the security requirement, while any other costs (not already apportioned according to the network security rule) associated with any reinforcement of assets to ensure the network fault levels remain within rating will be apportioned according to the fault level rule.

Reinforcement costs will be calculated as follows to determine the proportion of the reinforcement costs that should be paid by a connecting party.

The proportion of reinforcement costs to be charged to the Connecting Party will normally be determined by scale of the cost apportionment factor as determined by the apportionment formulae set out in sections 3.6 and 3.7. Sections 9.3.10 and 9.3.11 provide worked examples of the effect of the formulae.

3.6 Security Reinforcement

The reinforcement works will be driven by either thermal capacity or voltage, or both, and assessed against [Engineering Recommendation P2/6](#).

Deleted: 5

$$\text{Cost apportionment factor (\%)} = \frac{\text{Required Capacity} \times 100}{\text{New Network Capacity}} \quad (\text{max } 100\%)$$

The New Network Capacity is the secure network capacity following the reinforcement of the relevant assets.

3.7 Fault Level Reinforcement

$$\text{Cost apportionment factor (\%)} = \frac{3 \times \text{Fault level contribution} \times 100}{\text{New Equipment Fault Level Capacity}} \quad (\text{max } 100\%)$$

The reinforcement works are driven by fault level restrictions. The rule will be used for all equipment types and voltages. The rule recognises that existing network fault levels are predominantly driven by the system connections (transformer impedance) and therefore the capacity is limited to the remaining headroom. It uses the 'New Equipment Fault Level Capacity' which is the equipment rating following the replacement of assets.

3.8 Speculative Connection Enquiries

There are circumstances where we are asked to provide indicative quotations and firm quotations for infrastructure and/or connections to projects of a speculative nature. These circumstances include:

- where end users are not known;
- where the detailed electrical load requirements of end users are not known;
- where the development is phased over a period of time and the timing of the phases is unclear;
- where the capacity requested caters for future expansion rather than the immediate requirements of (an) end user(s);
- where the capacity requested caters for future speculative phases of a development rather than the initial phase(s) of the development; and
- where infrastructure only is being provided, with no connections for end users requested.

Where we deem a project to be speculative under these or other circumstances, we reserve the right to charge for the full cost of the work including any reinforcement and to apply an additional charge to reflect ongoing operation, repair and maintenance costs.

3.9 Temporary Connections

If you require a connection for temporary supplies, for example for 12 months, you will be charged the full costs of the work to be undertaken and the assets to be installed and recovered by NEDL for the purposes of making the connection. A portion of the connection charge in respect of assets that are recoverable and will be re-used by NEDL following disconnection may be waived or refunded at our discretion, as negotiated between the parties and described in the connection offer.

Part 2 Connection Charges and Your Options

4 Connection charges and your options

NEDL offers a complete connection service from initial discussions, design, detailed proposals and planning through to installation and commissioning. Final energisation is the responsibility of your electricity supplier. For this, you will need to appoint a supplier in sufficient time for them to make the necessary arrangements.

When you approach us for a connection we aim to provide a high level of customer service. We will discuss your requirements and make you a connection offer. If any work is required on our distribution system, we will either:

- outline the work involved and provide an indicative cost; or
- provide you with a quotation.

Our quotations are simply aimed at meeting your needs and recovering our reasonable costs.

Some aspects of the provision of connections to the network of NEDL are open to competition. You may therefore choose to ask us to provide a quotation for all the work required on your connection. Alternatively, you may wish to use a consultant or contractor as a "representative" to apply on your behalf and/or carry out some connection work for you. If you choose to have a representative, you should ensure that you have formally authorised them to represent you. Representatives should note that we may ask for written confirmation of such authorisation.

Work is progressing at a national level to develop increased competition in connections. Some contractors are now accredited to carry out certain types of connection work, including electrical work, under the Lloyd's Register ("Lloyd's") accreditation scheme. Lloyd's accredit companies that wish to work for customer to provide electrical connections for adoption by us. We are also happy to consider contractors that are accredited under other similar schemes. Please refer to section 7 for more information.

The work that such contractors can carry out for you is called contestable and the work we must do is called non-contestable. Generally, the split of these works is as follows:

Contestable	Non-contestable
<ul style="list-style-type: none"> • work carried out on the new connection assets - this includes design of the new connection, installation and recording activities, but excludes any upgrading or replacement of existing assets. 	<ul style="list-style-type: none"> • connection point determination (electrical assessment of our network); • design approval; • wayleaves; • diversions; and • up-stream reinforcement (connection reinforcement).

Table 1 - Split of contestable and non-contestable activities

4.1 Purpose of this document

This document describes the terms and conditions under which you may obtain a new, increased or reduced connection to NEDL's distribution system. It contains the detailed terms and conditions which apply when requesting a new connection, and provides guidance on the procedure that needs to be followed if you want a suitably accredited third party contractor to undertake the contestable works.

This statement sets out the principles used to calculate connection charges. Our aim is to provide a clear and understandable guide to allow a reasonable estimate of charges for works undertaken by NEDL and a guide to those areas of connections open to competition.

In this statement the words 'you', 'your' and 'yourself' refer to you, your company or agent, and 'we', 'us', 'our' and 'ourselves' refer to Northern Electric Distribution Ltd (NEDL).

4.2 Persons entitled to apply for connection

Subject to the Act, any person may apply for a connection to our distribution system to be used for the purposes of receiving a supply of electricity.

If you would like a connection to our system for the purpose of generating electricity or for supplying electricity to others, you need to be authorised by licence or by exemption under the Act.

4.3 Procedure for obtaining a connection

The remainder of the document provides details of the following steps of the procedure for obtaining a connection:

- Section 5 provides an overview of customer quotations
- Section 6 outlines work that NEDL must do
- Section 7 outlines your choices
- Section 8 outlines other connection activities available
- Section 9 outlines a broad range of indicative charges
- Section 10 outlines your rights
- Section 11 contains general information including terms and conditions.

5 Customer Quotations

5.1 Initial request from customer - information required

Before we can assess your request and provide a quotation or point of connection, you will need to provide us with details of the premises or distribution system from which the connection to NEDL's system is required; an indication of the date when you need the connection to be made; and the maximum connection capacity that you require in kVA.

5.2 What to expect at the quotation stage

The level of detail we require from you generally depends on the level of information you require from us. For a new or increased connection, where you are clear about the equipment to be installed in the premises and you are clear when you require the connection, you may ask us for a formal connection offer, which is usually in the form of a quotation. Alternatively, you may just want an indication of likely costs.

5.2.1 Formal quotation

If a formal connection offer is what you need, you should provide us with as much information as you can, including:

- plans showing the location of the site and appropriate drawings of the premises;
- the maximum power that you require i.e. in kVA or MVA;
- when you require the connection and/or timescales for your project;
- your preferred supply voltage;
- details of any special equipment or large electrical loads, including motors or electric heating;
- the nature of the end use e.g. domestic, commercial or industrial; and
- ground conditions on your site if known (for example, unmade ground, concrete etc), or any known flood risk.

A formal quotation will outline our terms and conditions for the connection and any work involved, our charges and an estimate of when the connection can be made available. The quotation will be open for acceptance for a period stated in the quotation, typically 28 days.

The work to be done and the connection charge payable will depend on your requirements and on the condition of our system at the point of connection, as well as other characteristics relevant to the connection. You should assume that all civil works on site for cable routes, metering positions and any substations are your responsibility, unless otherwise indicated by us.

Please Note: The information that you provide to us is important, as we will base our design and connection offer on what you confirm to us.

5.2.2 Indicative quotation

You may not want a formal connection offer; you may just need an indication of the likely cost of a connection to meet your needs. In return for basic information, such as a site location plan and the likely maximum capacity required, we will provide an indicative cost. As part of this indication we may outline the possible work required and suggest a typical lead-time for the provision of the connection.

An indicative quotation is not a formal connection offer or quotation capable of acceptance. We may outline some of the assumptions we make to prepare indicative costs, but we are unlikely to carry out detailed design work to prepare the indicative quotation and there are obvious risks for you if you use such an indication as a basis for your project planning and budgets.

5.2.3 Helpful advice - ways to reduce your connection charge

The most effective way to minimise your connection charge is to talk to us about ways of reducing the amount of work involved. The following list suggests ways of doing this that you might wish to consider:

- in general, reducing the engineering plant, materials and labour, results in a lower connection cost;
- if you are able to provide suitable cable / overhead line routes across your property; and
- if you can clarify your load requirements at the application stage this may reduce the time taken to design the connection and produce a quotation.

You may want to carry out excavation on your own land yourself. Other similar possibilities are:

- provide and install suitable cable ducts, including safety marker tape or tiles;
- provide and install suitable road crossing ducts if necessary, including safety marker tape or tiles;
- install an outside meter cabinet;
- if you can select an acceptable metering position as close to our existing network as possible, this can reduce the length of cable, and reduce the cost;
- if you want connections for multiple-occupancy premises, the minimum-cost solution is usually a suitable ground floor multiple connection position; and
- if we can carry out our work in our normal working hours of Monday to Friday 9am to 5pm.

Where a new substation is required, you may want to consider the following options:

- provide a substation site at the optimum position (near existing circuits) in discussion with us;
- provide the substation site / land at no cost; and
- provide a suitable new substation base and building.

All cable ducts, safety marker tape or tiles and any substation work must be to our specifications.

5.3 Payment policy

In general we require payment of connection charges in full before we make the connection(s) available for use. For connections where the work is minimal or can be completed quickly we recommend payment along with your acceptance of our quotation, as this will minimise any delays in making the connection(s).

We will consider phased payment for high voltage and extra high voltage connections and development projects.

5.3.1 Charges for design work

We may charge for design work, network studies and other costs associated with providing estimates. Please refer to section 9 for further details.

5.4 What to expect after accepting a quotation

Where you have chosen to have NEDL carry out all the work required on your connection then we will agree a mutually acceptable date with you to start the work.

Where you have chosen to use your own contractor to carry out some of the connection work, your representative or contractor should send a programme of work to NEDL (this is best sent with the acceptance letter). We will then plan and schedule the non-contestable connection work.

5.4.1 Connection agreements

For most simple low voltage (LV) connections we do not require a site-specific connection agreement between you and us. For larger connections including larger LV connections, those involving new substations, high voltage (HV) connections, extra high voltage (EHV) connections, generators and abnormal loads we may seek to enter a site-specific connection agreement with you.

5.4.2 Supplier appointment - provision of information

Energisation is the responsibility of your electricity supplier. You will need to appoint a supplier in sufficient time for them to make the necessary arrangements. Your supplier will need a Meter Point Administration Number (MPAN) to register as your electricity supplier. The MPAN will be provided by us.

6 Non-contestable work to be carried out by NEDL

6.1 Connection work

NEDL is required to carry out connection work and may do this work itself or appoint a sub-contractor.

6.2 Non-contestable work

If you decide to employ another approved installer to carry out some or all of the contestable work, there will still be work that NEDL must do. Work that NEDL carries out is described as *non-contestable*.

Before we connect cables, lines and equipment that have been installed by your contractor to our existing network and adopt them, there are actions we need to perform to ensure that we are willing to connect to the new assets. The non-contestable activities in relation to new housing are:

- determining the point of connection;
- obtaining all wayleaves and easements;
- approving designs;
- obtaining consents from third parties, including landowners;
- carrying out upstream reinforcement;
- carrying out diversion works;
- carrying out quality assurance inspections; and
- preparing and entering into an adoption agreement.

You should note that there are costs associated with non-contestable work and the charges for this will need to be paid by you or your appointed agent.

6.3 Network assessment and design fees

In general, for each connection request, we will provide one indicative offer (if required) and one formal connection offer free of any up front charge. We may charge for providing additional offers and we reserve the right to add the cost of any design work to the final connection charge. The entitlement to this sits with the customer or the customer's appointed sole agent and includes the provision of a point of connection where requested: the point of connection may itself be indicative.

Where the network assessment studies are significant, for speculative projects, multiple sites or technical options, we may require charges to be paid in advance.

See section 9 for indicative charges.

Deleted: The majority of connection work that we are required to carry out is undertaken on behalf of NEDL by a sub-contractor, Integrated Utility Services Ltd (IUS), an affiliated company.¶ IUS is NEDL's contractor for both non-contestable work and such contestable work as NEDL may be asked (and required by the Licence) to undertake.

6.4 Requesting a connection from us

If you require a new or modified connection to our system, or point of connection information as appropriate please contact NEDL at:

NEDL Connections
NEDL
Cargo Fleet Lane
Middlesbrough
TS3 8DG

Phone: 0800 59 0915

Fax: 01642 25 8100

Standard connection application forms are available for this purpose to help you provide the necessary information to us so that we can design the connection and provide a quotation.

7 Work that NEDL or your contractor may do

7.1 Contestable works

Instead of asking us to carry out all the connection work, you may decide to appoint another approved installer to carry out some of the work involved in the connection. Work that may be carried out by an installer other than NEDL is known as contestable works.

Your contractor and any subcontractors need to be accredited by Lloyd's if the resulting assets are to be adopted by us. The accreditation needs to cover all aspects of the work undertaken by such contractor or sub-contractors, including design, management, supervision, on-site works and testing. If you want to know more about accreditation, please contact The Accreditation Scheme Co-ordinator at Lloyd's Register on 0247 651 8603. The Lloyd's web site also gives a list of the national electricity registration scheme (NERS) registered service providers at http://www.lr.org/market_sector/utilities/NERS/index.htm

Certain work such as excavation and reinstatement on your own land does not require a contractor to be Lloyd's accredited. We will provide guidance to you on trench depth and the requirement for any cable ducts for you to make the necessary arrangements. We will not be responsible for any damage, trench guarding, injuries or reinstatement problems associated with your work.

Reinforcement and Diversions

Certain types of reinforcement and diversionary work may be carried out by suitably accredited ICPs for adoption by NEDL. The scope of such work is limited to reinforcement and diversionary works associated with a connection which:

- are new works that are physically and electrically separate from existing DNO infrastructure;
- do not require access to existing DNO operational areas;
- are fully funded by the single third party who is seeking the connection; and
- are restricted to works to install overhead lines of standard wood pole construction and underground cables at voltage levels not exceeding 66kV and HV/LV distribution substations.

The design of reinforcement works can require a large volume of information about the distribution network. The level and complexity of information that would need to be made available to allow the ICP to carry out such design works are likely to outweigh the benefits of including design work within the scope of contestability. The design of connection reinforcements therefore remains non-contestable.

The design of the majority of diversion projects associated with connection projects is likely to be less complex than the design of reinforcement schemes. The design of diversionary works can be contestable for overhead lines of standard wood pole construction and underground cables not exceeding 66kV and for HV/LV distribution substations. The dismantlement and disposal of existing DNO assets remains non-contestable because it would require access to existing DNO assets and/or operational areas.

Inspection and monitoring of contestable work by NEDL

The level of inspections and number of visits may depend on the activity being undertaken and our experience of your contractor. The stages that may be witnessed will be agreed between us. We may also, at our discretion, choose not to visit.

Notice

Your contractor should give us at least forty-eight hours' notice of the activities listed below, giving an indication of the times at which the activities can be observed. This is to allow us the opportunity to monitor the works, should we so wish. The activities which we require notice of are:

- Pulling and laying of cables;
- filling of any trench containing HV cables or LV mains cables;
- erection of any HV plant;
- testing and/or commissioning;
- sagging of overhead line conductors; and
- installation of link boxes, joint pits or feeder pillars;

We may also wish to inspect on any other occasion specifically referred to in the adoption documentation or as otherwise indicated by us.

Charges

For estimation of charges for monitoring and inspection, each of the following stages will attract a charge:

- each identifiable HV and LV mains cable run;
- every ten service joints on housing developments;
- each overhead line section;
- each HV switchgear installation;
- each link box, joint pit or feeder pillar;
- charges are £100 per inspection visit; and
- charges for re-inspection after failure will be £100.

The charge is based on the cost of inspecting up two items of similar work on the same visit.

7.2 Your options

See the summary table below for details of who can do what in each of the three possible scenarios for obtaining a connection:

	ACTIVITIES	OPTION 1 All work by NEDL	OPTION 2 Some non- electrical work by your contractor	OPTION 3 Some electrical and non- electrical work by an accredited contractor
1.	Carry out work to determine the point of connection	NEDL	NEDL	NEDL
2.	Obtain all legal and wayleave permissions			Your Accredited Contractor
3.	Produce detailed design for on-site works (Note: under option 3 - contractor designs are subject to our approval)			
4.	Project manage the connection			
5.	Provide materials to our specification			
6.	Carry out cable trenching work on-site			
7.	Install ducts on-site		Your Contractor	
8.	Carry out substation building and civil work on-site		NEDL	
9.	Carry out non-electrical work off-site (including meeting provisions of the New Roads and Street Works Act)			
10.	Carry out electrical work on the new extension to our system (Note: under option 3 - no live working)			
11.	Carry out any reinforcement work on our existing system			
12.	Carry out Quality Assurance inspections of new work, test and connect to our system			
13.	Install metering and make internal wiring live		Your Supplier	

Table 2 - Options and responsibilities for new metered connections

7.3 Points to note regarding adoption of competitive works

In order to ensure that any works carried out by your contractor are successfully adopted by NEDL, you should be aware of the following:

- we will communicate all charges for non-contestable works to you or your agent;
- we must approve your contractor's design if you want us to adopt the installation;
- your contractor's design work must be in accordance with our specification;
- in general we will provide point of connection information, via you, for your contractor. Once the design has been approved we will deal with your contractor directly regarding the technical detail. We will communicate point of connection information direct to your contractor, subject to a letter of authorisation from you.
- your contractor will be responsible for the design of the contestable work, based on our point of connection information. This design will be subject to our approval if we are to adopt the assets;

- you should appoint a suitably-accredited contractor to carry out contestable works;
- you must notify us of your contractor, once appointed;
- prior to appointing a contractor you may wish to satisfy yourself that your contractor is accredited to complete all the work to your and our satisfaction;
- your contractor will work for you and not for NEDL;
- you will be responsible for managing your contractor;
- we may not supervise your contractor's site works;
- we may notify any issues relating to the quality of your contractor's work directly to you or your contractor;
- we will notify you of any health and safety issues that we encounter relating to your contractor's work;
- in general you will be responsible for signing our adoption agreement, not your contractor *; and
- your contractor must fulfil all statutory obligations and responsibilities relating to his site works.

Note: * We can only adopt assets from the party that owns them. We may ask you to clarify in writing the ownership of the assets - for example, who holds the Deed of Title.

8 Other Connection Activities

8.1 Unmetered connections

The majority of unmetered connections are provided in relation to street lighting and other street furniture. A maximum load of 500 watts per connection applies to new unmetered connections or modified connections.

NEDL offers a "rent-a-jointer" scheme as recognised by Ofgem. This is a scheme for public lighting authorities (PLAs) and their appointed agents where arrangements for point of connection approval and design are in place. It offers a PLA the facility to "block-book" the services of a jointing team subject to availability, along with the associated supervision and safe systems of work. The scheme is for pre-arranged work only, with requirements for specified information to be exchanged, and operates under our safety management system.

We will be happy to discuss our charges for our "rent-a-jointer" service on application - please see contact details in section 6.4.

See the summary table on the next page for details of who can do what across each of the three possible scenarios for obtaining an unmetered connection:

Deleted: Integrated Utility Services Ltd carries out street lighting new connection and service replacement work on behalf of NEDL.¶

	ACTIVITIES	OPTION 1 All work by NEDL	OPTION 2 Some non-electrical work by your contractor	OPTION 3 Some electrical and non-electrical work by an accredited contractor	
1.	Carry out work to determine the point of connection	NEDL	NEDL	NEDL	
2.	Wayleaves and easements and other necessary conditions			Your Contractor	Your Accredited Contractor
3.	Produce detailed design for on-site works				
4.	Project manage the connection				
5.	Provide materials to our specification				
6.	Carry out cable trenching work on-site				
7.	Install ducts on-site		NEDL	NEDL	
8.	Carry out non-electrical work (including meeting provisions of New Roads and Street Works Act)				
9.	Carry out electrical work on the new assets (Note: under option 3 – no live working)				
10.	Carry out live jointing				
11.	Carry out Quality Assurance inspections of new work and of test and connects to newly installed asset				
12.	Install new connection				
13.	Live transfers				
14.	Permanent disconnections				

Table 3 - Your options for unmetered connections

8.2 Disconnection Services

If you, or your supplier, wish the supply to be disconnected, then you must provide a minimum of two days' notice or such other period as may be specified in the use of system agreement between your supplier and us. There will also be a charge for this work.

Temporary de-energisation (and subsequent re-energisation) resulting from your or your supplier's failure to comply with the terms of the use of system or connection agreement as the case may be, or carried out at your or your supplier's request, will be at your or your supplier's expense.

If it becomes necessary to disconnect your supply and remove our equipment from site, for any reason, then any payments that are outstanding in providing the connection will become due immediately. We shall, where necessary, also seek to recover any contribution that, save for recovery, would remain unpaid due to lack of system revenue.

If you require your supply to be permanently disconnected then you should notify your energy supplier and apply to us in writing to:

Customer Services
NEDL
Manor House
Station Road
New Penshaw
Houghton-le-Spring
DH4 7LA

If you wish to telephone us prior to writing, the number to ring is: 0845 070 7172.

On receipt of your request we will take all reasonable steps to remove our equipment in accordance with your reasonable requirements, though this will depend upon our programme of work at that time. However up to two months' notice may be required to remove HV substation plant. In the case of an EHV connection we should be consulted at an early stage and a programme for the removal of equipment will be subject to individual assessment.

Upon the termination of the connection agreement we reserve the right to remove our equipment and you will be liable for the cost of this work. Equipment that it is not cost effective to recover (e.g. buried cables) will normally be made safe and left on site. However, if you require this equipment to be removed by us, then you will be charged the full cost of this work. All such equipment will remain our property unless otherwise agreed in writing.

8.3 Small generators connected to the low voltage network

There is increasing interest in connecting small generation units to the low voltage network. Generators exporting up to 16A per phase are being classed as "small" and this covers most of the photo voltaic cell and domestic combined heat generators currently available.

If you intend to install such equipment, the generators and the installation should comply with Engineering Recommendation G83/1 and your installers should familiarise themselves with the guidance provided in this document.

For single generator installations connected to an existing service connection there will be no charge, but you must provide us with details of the equipment you are installing.

Larger projects involving either multiple generator installations at the same property or single generator installations in multiple new or existing properties in the same area may necessitate a design study by us prior to installation. Where such projects are being planned you should contact us prior to commencement of the project to provide us with details of the equipment you are proposing to install and where you are proposing to install it. We may charge you for any study considered necessary and, if the results of the study require us to modify our network, we may charge you for the necessary work.

A copy of Engineering Recommendation G83/1 is available from:

Engineering Directorate
Energy Networks Association
18 Stanhope Place
Marble Arch
London
W2 2HH

Copies of the connection appropriate application forms cited in Engineering Recommendation G83 are freely available on the Energy Networks Association website: address to be confirmed

9 Schedules, Tables of Charges and Examples

9.1 Domestic tariff support allowance

Tariff support has been withdrawn and will not be applied to connection charges from 1 April 2005.

9.2 Indicative charges

In this section, Table 4 to Table 8 set out a range of indicative charges for typical activities associated with the provision of new connections or associated network reinforcement and a brief description. This includes activities such as network assessment and design, obtaining wayleaves and non-contestable charges.

The examples of typical connections in section 9.3 are intended to be indicative only and you should bear in mind that the actual cost will depend on the specific details of the scheme. You should assume that all civil works including ducts, metering cabinets and substation buildings are your responsibility, unless otherwise indicated by us.

9.2.1 Factors influencing costs

When we design your connection there may be factors that are outside our control and which can have an effect on the final cost of the scheme. The following list is not intended to be exhaustive, but provides an indication of elements to which we may give consideration at the design stage:

- standards governing our system;
- the length of cable or line required from our existing system;
- the size of your demand in relation to available capacity of our existing system, including the age of the assets and the condition of our system;
- whether any extension or reinforcement of our existing system is by underground cable or overhead line;
- the type of ground requiring excavation; the type and extent of reinstatement necessary (including New Roads and Street Works Act requirements);
- the need for road crossings;
- the availability of wayleaves / easements for cables or lines including any consents;
- the availability of suitable substation sites including any necessary consents; and
- the necessity for overtime working.

9.2.2 Items included in costs

The provision and installation of all electrical lines and electrical plant required to make a connection will be included in the cost quoted. By way of example this will generally include our providing, at prices including on-costs, the equipment, labour, materials, installation and transport, plus all other overheads including the cost of the design and specification of the connection scheme requirements. On certain projects which have a high capital cost and long lead time, it may be necessary to charge interest during the construction period or agree increases in our charges over a period.

9.2.3 Illustrative list of abnormal services which may be reflected in the connection charge

The following is a list for illustrative purposes only of abnormal services which may be reflected in the connection charge:

- service termination where you fail to provide and/or install ducts to facilitate the installation of services into the premises and suitable accommodation for the termination equipment;
- progression of work required other than in an orderly fashion in accordance with normal engineering policies and practices, which thus imposes additional costs;
- transformer / substation sites not provided to us in suitable locations at normal prices or rents, taking account both of cable access and access by personnel;
- multiple occupancy premises where the developer fails to provide all necessary civil work including ducts, access ways, chases and covers, etc; and
- loads with abnormal characteristics which affect the security and standard of service on the System (for example arc welders and large motors).

We may be required to recover from you additional costs which could not have reasonably been foreseen at the time of providing a quotation. Where we identify such costs during our works, we will endeavour to provide an estimate of the likely cost. Alternatively, you may ask us to suspend works and issue you with a revised connection charge quotation.

Activity	Description	Illustrative Charges
Low voltage service line and termination	Separate connection by adding an extension fuse to an existing suitable termination fuse unit.	£175
	Single phase 100 amp underground connection, using up to 20 metres of cable, including cable joint hole and 3m of trench, cable joint, and termination equipment (duct installed by you).	£500
	Three phase up to 60kVA underground connection, using up to 20 metres of cable, including cable joint hole and 3m of trench, cable joint, and termination equipment.	£650
	Three phase up to 288kVA underground connection, using up to 20 metres of cable, including cable joint hole and 3m of trench, cable joint, and termination equipment.	£2,300
Extension of low voltage underground mains cable	Excavation and reinstatement of cable trench, including cable and installation.	£40 -£100 per metre (Subject to size of cable ground type and covering (i.e. Tarmac / concrete))
Low voltage cable jointing	Additional mains breeches joint	£300
	Additional insulated end	£175
	Additional service breeches joint	£200

Table 4 - Indicative charges for typical low voltage (LV) connections

For projects involving multiple connections within an agreed programme we are prepared to discuss project specific charges for cable jointing.

For other LV and HV projects please see the examples in section 9.3.

9.2.4 Extra high voltage (EHV) connections

EHV connections are designed on a project-specific basis and are often highly customised. To obtain a realistic indicative cost we would welcome close dialogue with you to jointly develop an appropriate scheme. This is particularly important with respect to generator

connections and electrically disturbing loads where the nature of the customer's equipment can have a major impact on the design. The following are illustrative costs for such projects:

Activity	Description	Illustrative Costs
Extension of EHV (33kV) mains	33kV overhead line per kilometre	£40,000
	33kV underground cable per kilometre	£230,000
New 33kV / HV substation	Single transformer primary substation, with 4 outgoing circuit breakers	£1,000,000
	Two-transformer primary substation, with 5-panel 33kV board and 12 outgoing circuit breakers	£2,200,000
Transformer change at existing 33kV / HV substation	Replace 33kV / HV transformer	£424,000

Table 5 - Indicative charges for typical EHV connections

The illustrative costs for substation work exclude cables, cable terminations and civil works.

Table 6 and Table 7, below, provide indicative charges for network assessment and design fees and for obtaining necessary wayleaves, easements and consents.

Activity	Illustrative Charges
Up to four services from an existing main (service capacity up to 60 kVA)	£60
Housing (LV connection for 5 to 20 houses)	£900
Housing (LV connection for 21 to 50 houses)	£1,400
Commercial / Industrial (LV connection) up to 65kVA)	£900
Commercial / Industrial (LV connection) over 65kVA	£1,400
Commercial / Industrial (HV connection up to 3 MVA)	£1,820
Commercial / Industrial (over 3 MVA)	Individually Assessed
Isolated rural property	£550

Table 6 - Indicative charges for network assessment and design charge (including detailed design work and estimate of the contestable work)

9.2.5 Design work for indicative quotations

In general, design work for indicative quotations is free of charge for the first connection option you request and full cost for the second option. Please refer to the above table for the appropriate indicative charges.

9.2.6 Design work for formal connection offers

In general, the first connection option you request is free of an up-front charge as we may include the charge within the connection charge. Please refer to the above table for the appropriate indicative charges.

9.2.7 Significant design studies

Where network studies are significant, including for speculative projects, multiple sites, multiple technical options, adverse load characteristics and generators, we may require charges to be paid for each option and in advance.

9.2.8 Redesign

This will be applicable where it is necessary to recalculate conductor sizes or amend cable routes, substation positions or connection proposals. The second and each subsequent

connection option you request for the same site may be charged at 50% of initial formal design charges indicated in the above table.

Activity	Illustrative Charges
Housing (Urban)	£1,000
Housing (Rural)	£1,000
Isolated rural property	£500
Commercial / Industrial (customer-owned substation)	£1,000
Commercial / Industrial (HV or LV connection)	£1,800

Table 7 - Indicative charges for obtaining necessary wayleaves easements and consents

The table below gives an indication of non-contestable charges.

Type of Connection(s)	Number of Connections / Total Capacity of Connections	Point of Connection Information	Design Approval Per Design
Housing	Administration charge	£60	
	Up to 4 houses	£60	£60
	5 to 20 houses	£150	£200
	21 to 50 houses	£270	£340
	over 50 houses	£450	£560
	Isolated developments or rural properties	£360	£360
	Large developments over 100 houses	price on application	price on application
Commercial / Industrial	Administration Charge	£60	£60
	Up to 65kVA	£60	
	66kVA to 288kVA	£270	£340
	289kVA to 800kVA	£450	£560
	801kVA to 3000kVA	£660	£660
	Over 3000kVA or electrically disturbing loads or generation	price on application	price on application

Table 8 - Indicative non-contestable charges for point of connection information and design approval

Notes: Charges will apply on each occasion that we are asked for point of connection information, design approval or re-approval. Where different options are selected, charges will apply to each option. Where we have already determined the point of connection we will apply an administration charge to cover the cost of your enquiry.

9.2.9 Additional design, assessment and / or investigation charges

There are design issues that may cause an increase in the above indicative charges at a rate of approximately £60 per hour. Examples include:

- wayleaves;
- CDM compliance;
- environmental issues;
- remote connections;

- other significant planning issues; and
- listed buildings.

9.2.10 Quality assurance

Our aim will be to recover our reasonable costs for carrying out quality assurance visits associated with adoption and the issue of any subsequent defect notices to bring quality issues to your attention. Visit charges for street lighting and housing connections will typically be £100 per visit and will be subject to agreeing a visit schedule for each specific project. Quality assurance visits for other projects will be considered upon application.

9.3.4 Example 4 - Industrial or commercial customer connection up to 5000kVA

This illustrates an indicative cost to provide a firm connection of up to 5000kVA to a remote substation. The point of connection between NEDL's distribution system and the customer's wiring installation would be at the 11,000 volt terminals of our metered circuit breaker, which would be located within the substation.

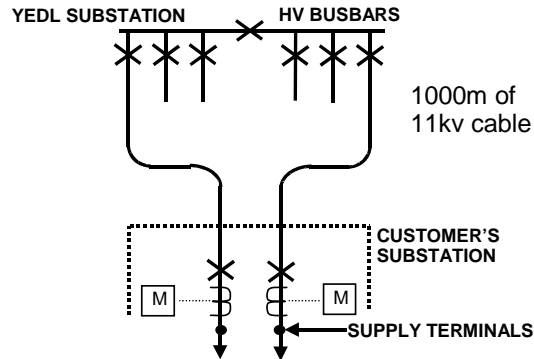

The indicative cost for this work would be £190,000. This would be comprised of £90,000 for the high voltage cable and £100,000 for the four circuit breakers necessary for the firm connection.

Connection Cost **£190,000**

9.3.7 Example 7 - Industrial or commercial customer connection of 200kVA

This illustrates an indicative cost to provide a connection of 200kVA involving reinforcement by changing a transformer to accommodate the new demand. This example shows the application of the cost apportionment rule for system security.

This example involves laying a cable from the local substation into the customer's premises. The transformer at our substation would also have to be changed for a larger unit with a rating of 800kVA. The security apportionment rule is used to calculate the cost apportionment factor applicable to the cost of this new transformer. The resulting proportion of the reinforcement work is then added to the cost of the dedicated assets to produce the total connection charge.

The dedicated connection assets consist of a new a cable from the substation to the customers premises at an indicative cost of £18,000 for the low voltage cable and £2,000 for the termination, a total of £20,000.

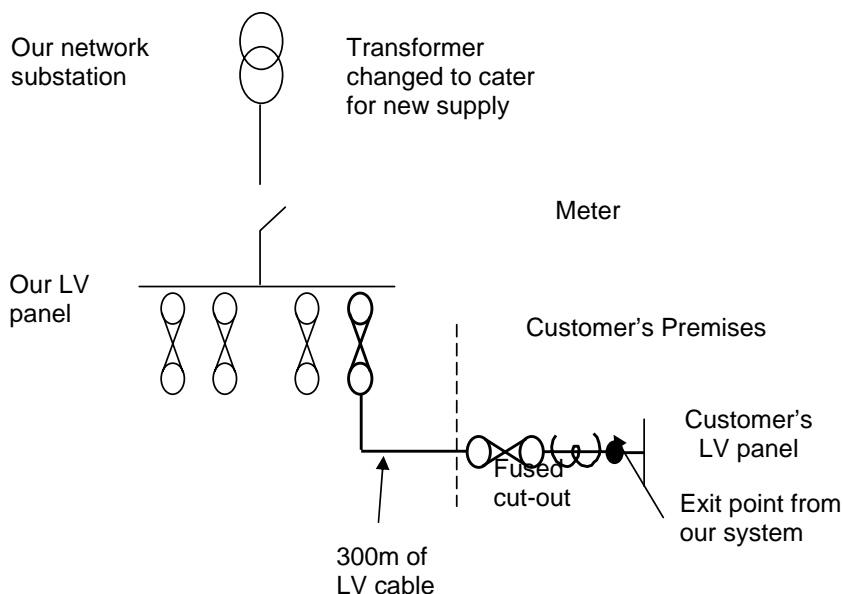

Security capacity calculation components

Requested capacity	=	200kVA
New network security capacity	=	800kVA
Cost of new transformer	=	£ 7,000

Security capacity calculation

$$\text{Security CAF} = \frac{\text{Required capacity} \times 100 \%}{\text{New Network Capacity}} \quad (\text{maximum } 100\%)$$

$$\text{Security CAF} = \frac{200 \times 100\%}{800} = 25\%$$

NEDL's Connection Charging Methodology and Statement from 1 April 2007

Security reinforcement charge = 25% of £7,000 = £1,750

The total connection charge is established by adding the cost of the dedicated assets to the above security reinforcement charge.

Security reinforcement charge	=	£1,750
Dedicated assets	=	£20,000
Total charge	=	£21,750

9.3.8 Example 8 - Industrial or commercial customer connection of 200kVA

This illustrates an indicative cost to provide a connection of 200kVA. This would involve laying a cable from the local network into the customer's premises. The point of connection between NEDL's distribution system and the customer's wiring installation would be the outgoing terminals of our cut-out, which would normally be located within the customer's switch room.

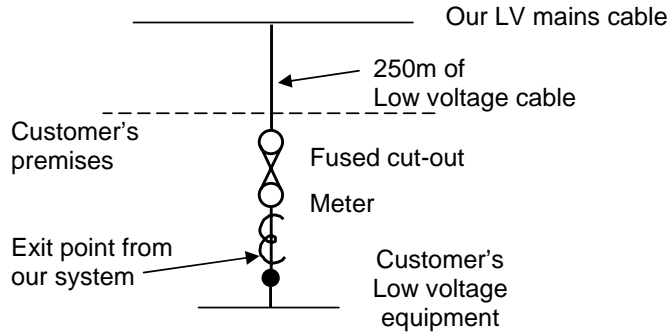

The indicative cost for this work would be £17,000. This would be comprised of £15,500 for the low voltage cable and £1500 for the termination.

Connection Cost **£17,000**

9.3.10 Example 10 – Demand connection for up to 3000kVA including reinforcement

This illustrates an indicative cost to provide a connection for up to 3000kVA of new demand involving reinforcement. The example shows the application of the cost apportionment rule for system security.

The dedicated connection assets consist of a new a cable from our primary substation to a new substation at the customer's premises. The indicative cost for the dedicated assets would be £100,000. This would be comprised of £40,000 for the high voltage cable, £35,000 for the overhead line and £25,000 for the high voltage circuit breaker at the customer's substation.

This reinforcement work is the replacement of our substation 11 kV switchgear with switchgear of a higher electrical rating. The security apportionment rule is used to calculate the cost apportionment factor applicable to the cost of this new switchgear. The resulting proportion of the reinforcement work is then added to the cost of the dedicated assets to produce the total connection charge.

This example assumes that the new 11kV switchboard has a demand capacity of 30,000kVA.

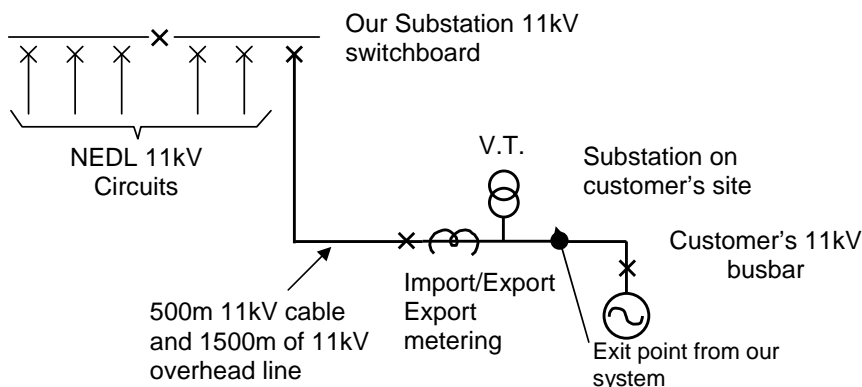

Security capacity calculation components

- Requested capacity = 3,000kVA
- New network security capacity = 30,000kVA
- Cost of new Switchboard = £450,000

Security capacity calculation

$$\text{Security CAF} = \frac{\text{Required capacity} \times 100\%}{\text{New Network Capacity}}, \quad (\text{maximum } 100\%)$$

$$\text{Security CAF} = \frac{3,000 \times 100\%}{30,000} = 10\%$$

Security reinforcement charge = 10% of £450,000 = £45,000

NEDL's Connection Charging Methodology and Statement from 1 April 2007

The total connection charge is established by adding the cost of the dedicated assets to the above security reinforcement charges.

Security reinforcement charge =	£45,000
Dedicated assets =	£100,000
Total charge =	£145,000

9.3.11 Example 11 – Generation connection for up to 3000kVA including reinforcement

This illustrates an indicative cost to provide a connection for up to 3000kVA of new demand involving reinforcement. The example shows the application of the cost apportionment rule for fault level.

The dedicated connection assets consist of a new a cable from our primary substation to a new substation at the customer's premises. The indicative cost for the dedicated assets would be £100,000. This would be comprised of £40,000 for the high voltage cable, £35,000 for the overhead line and £25, 000 for the high voltage circuit breaker at the customer's substation.

This reinforcement work is the replacement of our substation 11 kV switchgear with switchgear of a higher fault level rating. The fault level apportionment rule is used to calculate the cost apportionment factor applicable to the cost of this new switchgear. The resulting proportion of the reinforcement work is then added to the cost of the dedicated assets to produce the total connection charge.

This example assumes that the new 11kV switchboard has a fault level capacity of 315,000kVA and this is the new network fault level capacity.

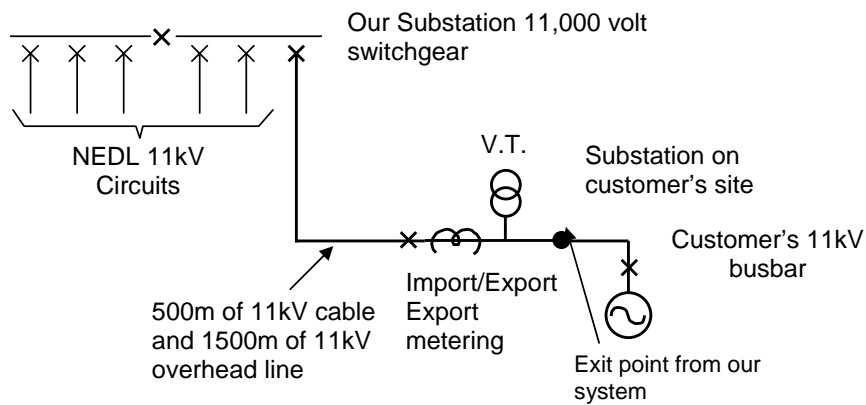

Fault level capacity calculation components

Requested fault level capacity	= 24,000kVA
New network security capacity	= 315,000kVA
Cost of new Switchboard	= £450,000

Fault level capacity rule

Fault Level CAF = $\frac{3 \times \text{fault level contribution from Connection} \times 100 \%}{\text{New Equipment fault Level Capacity}}$, (maximum 100%)

$$\text{Fault Level CAF} = \frac{3 \times 24,000 \times 100\%}{315,000} = 22.9\%$$

Fault level reinforcement charge = 22.9% of £450,000 = £103,050

NEDL's Connection Charging Methodology and Statement from 1 April 2007

The total connection charge is established by adding the cost of the dedicated assets to the above security reinforcement charges.

Fault level reinforcement charge	=	£103,050
Dedicated assets	=	£100,000
Total charge	=	£203,000

10 Disputes

10.1 Dispute and determination procedure

In the event that you are in any way dissatisfied with a connection offer made by NEDL, we would ask that in the first instance you contact the person who has provided your connection offer. Following discussions, should any technical queries or other concerns still not be resolved to your satisfaction, then we would ask that you refer the issue to the NEDL Design Manager, Dewsbury.

Where you are not satisfied with the terms offered under either Section 16(1) of the Electricity Act 1989 (as amended by the Utilities Act 2000) or Condition 4D of our Licence and agreement with NEDL cannot be reached within a reasonable time, you may approach *energywatch* (the Gas and Electricity Consumer Council), an independent consumer body set up under the Utilities Act to protect your interests. Energywatch are able to offer advice and will look at your dispute but will expect you to let us try and sort it out first.

If you do take your complaint to *energywatch*, they will make it known to the Customer Service Manager in NEDL who is responsible for monitoring complaints with regard to any aspect of service carried out by or on behalf of NEDL.

Some costs which cannot be agreed upon can be referred for formal determination and, should *energywatch* be unable to resolve a dispute which is determinable, either party may request settlement by the Office of Gas and Electricity Markets (Ofgem). Energywatch will forward any such case to Ofgem at your request. Any requests for formal determination must be made within 12 months of the works being completed.

The relevant contact details are as follows:

Design Manager NEDL Mill Street East Dewsbury WF12 9AH Phone: 01924 869437	Customer Service Manager NEDL Manor House Station Road New Penshaw Houghton-le-Spring DH4 7LA Phone: 0191 333 7403
<i>Energywatch</i> North East 8 th Floor, Percy House Percy Street Newcastle upon Tyne NE1 4PW Phone: 08459 06 07 08	The Office of Gas and Electricity Markets 9 Millbank London SW1P 3GE Phone: 020 7901 7000 For further information on determinations go to Ofgem's website at www.ofgem.gov.uk

A customer may accept a quotation, pay the connection charge and have any work undertaken pending determination by Ofgem. If Ofgem determine that some of the original charges should be refunded they will be treated as if they were a security deposit under Section 20 of the Electricity Act. This means that interest will be paid on every sum of 50p held by us that needs to be refunded. Such interest will be payable in respect of every successive three-month period during which the sum involved remains in our hands.

11 General

11.1 Terms and conditions

Where the owner or occupier of the premises or an authorised supplier acting with the consent of the owner or occupier of the premises requires a connection, NEDL will normally assume that that person has given notice under Section 16 of the Electricity Act. Requests will be considered as a request under Condition 4 of our Licence where the connection is being provided for a person whom NEDL does not believe to be either the owner or occupier of the premises or the authorised supplier acting with the consent of the owner or occupier of the premises.

The assets installed or adopted by NEDL during the course of any works between the existing network and the new exit point will be owned, operated and maintained by us and we shall be entitled to use such assets for the purpose of giving supply to others.

Where the contestable works have been carried out by a third party on behalf of the person requesting the connection and that person requires the new assets which have been provided and installed to be adopted by NEDL, then the adoption agreement will state the terms under which the extension formed by the new assets may be adopted (following a nominal sum legal purchase from the third party if appropriate) and connected and may remain connected to NEDL's distribution system.

The costs to be recovered in the connection charge will be determined from the estimated costs of the minimum scheme which would be designed to meet the requirements of the connection and for the sole benefit of the party being connected, consistent with sound engineering practices and the scope of contestable and non-contestable works as defined in this statement, and subject to the specifications and standard sizes of equipment used by NEDL. Where the scheme actually designed and/or the assets to be installed are of greater size and capacity than the practicable minimum scheme required for that connection, the costs in excess of that minimum scheme normally will be borne by NEDL. Where the minimum scheme is capable of accommodating additional connections and the relevant parties agree at the time of application to pay a share of the connection costs, then the costs of the scheme will be apportioned accordingly.

In certain circumstances, however, the party seeking connection will be required to make a payment in respect of assets which have been installed previously by NEDL and which are used for the purpose of providing the connection. The provisions are contained within the Electricity (Connection Charges) Regulations 2002, as amended.

Where it is necessary to replace assets, which have been provided for the sole use of the connected party (and which continue to be required by that party), and the costs of such replacement are not recovered as part of the use of system charges, then such replacement will be at the expense of the connected party.

Where, on request, a connection is made at a voltage level higher than 11,000 volts or to a standard of security different from that normally provided by NEDL, the terms described in this statement and attached schedules may not apply. For example, connections required at EHV may have an impact on the transmission system. Under normal circumstances transmission system costs are communicated to us via ongoing exit charges. In the event of transmission system connection charges being applied we reserve the right to reflect such costs in our connection charge as appropriate.

The approval of Ofgem is required for connections at a lower standard of security. If this approval may be required, NEDL will seek guidance from and the subsequent approval of Ofgem. The cost of this work incurred by NEDL will be recovered from the person making the request for the lower standard connection.

11.2 Operation and maintenance costs

We may also charge to recover the costs of the anticipated operation, repair, maintenance and replacement of the equipment required for the connection (whether or not provided by NEDL) where those costs will not be recovered through use of system charges. The costs are derived from the annual estimated costs of work related to the parts of the system used for the connection. They are usually expressed as a percentage of the initial capital value of the assets or an annual sum. Where this includes assets provided by a third party this will be the value of such assets as assessed by us.

Where we apply such charges, for example in relation to enhanced connections or speculative developments, we will apply a rate of 0.98% per annum to the relevant asset value to calculate an annual charge. This rate has been determined to be appropriate from previous analysis of price control data in respect of OR&M costs and overall capital costs.

In the case of an enhanced connection where the assets to be installed are in excess of the minimum scheme the relevant asset value will be the difference between the value of the minimum scheme as estimated by us and the value of the enhanced scheme.

Where the connection is required for the purpose of providing capacity which will be taken up over a number of years or where the extent to which the supply will be taken up is not reasonably ascertainable at the time of connection, the capitalised operation, maintenance and repair costs may be payable in full in advance of any work on site.

We will consider requests to capitalise the annual charge and add it to the connection charge.

11.3 Connection charges

The work to be done and the connection charge payable will depend on the requirements of the person seeking the connection, on the condition of the distribution system at the point of connection and on other characteristics relevant to the connection, including the effective capacity and voltage level of the relevant part of the distribution system in relation to the requirements of the party seeking the connection. A statement showing circuit capacity and loading on specified parts of the distribution system and other relevant information will be provided on request, subject to a charge dependent on the amount of work involved to provide it.

11.4 Connection agreements

Persons being connected to NEDL's distribution system may be required to enter into an agreement (the connection agreement) with us, setting out the specific terms and conditions that will apply. Whilst such terms and conditions will be consistent with this statement, the terms of the connection agreement will take precedence. Where a person requires a supply of electricity pursuant to section 16(1) of the Act, the provisions of this statement are without prejudice to the provisions of sections 16 to 24 of the Act.

The connection agreement will set out NEDL's obligations regarding the connection, and will require the connected party to pay all and any charges due in respect of the connection as described in the connection offer, this statement and the accompanying schedules. It will also require the connected party to comply with the provisions of the Distribution Code (a copy of which is available from NEDL on request at a charge of £80 plus VAT per copy).

11.5 Reinforcement

Additional off-site works necessary to provide your connection to the distribution system (which for this purpose means works occasioned by the new or increased connection, but not for its sole use) will be charged for, subject to the following:

- charges for reinforcement will normally be based on the apportionment rules that are described in our methodology.. Previous related increases will be taken into account in determining the requested capacity to be applied under the rules.
- in general, charges will not take into account reinforcement more than one voltage level above the voltage of connection where the proposal or existing connection arrangement is of a type considered by us as typical of the majority of connection arrangements on our system; and
- for the avoidance of doubt, reinforcement which includes the provision of transformers shall be considered as being equivalent to the secondary voltage of the transformer equipment.
- Where a customer has funded reinforcement as part of a previous connection charge under the apportionment rules and applies for further capacity within 5 years, we reserve the right to re-apply the apportionment rule based on the capacity initially requested plus the further capacity requested.

In certain circumstances, the apportionment rules may not apply; in particular:

- where a speculative project is for infrastructure only. For example, cables to the boundary of a site where the developer does not require an exit point at that time;
- where a speculative project end users or their requirements are not known. For example, the developer will adapt the site and the loads to accommodate the end user's;
- where on a speculative project the capacity requested is significantly higher than the end user's initial requirement;
- if reinforcement is required to support abnormal electrical characteristics, for example, large motors, welders or abnormally excessive fault level contribution;
- where on a speculative project the connection involves additional assets necessary due to the nature of the end user's installation and where the additional assets would not be required if that installation were typical of the majority of installations connected to our network.

In such circumstances, reinforcement costs may be charged to the developer or customer in full.

11.6 High cost projects

Projects where the reinforcement element is higher than £200/kW are deemed to be high cost projects. Reinforcement costs above this threshold will be deemed as excess costs and will be charged in full to the customer as a connection charge. We also reserve the right to apply a charge to recover future operation, repair and maintenance costs in relation to the excess costs.

11.7 Enhanced connections

Where we may be asked to provide a new or modified connection to enhance it above the minimum scheme for the capacity required for the proposed connection, it may be necessary for us to install or adopt assets over and above those assets that would be required for the minimum scheme to cater for the end user's normal import or export capacity. Under such circumstances we may:

- charge for the full cost of the work;
- charge for the cost of any necessary reinforcement; and

- charge a capitalised sum to reflect ongoing operation, repair and maintenance of the additional assets.

Examples of enhanced connections include:

- connections designed to provide enhanced security of supply above that normally provided to the majority of similar customers;
- connections where the exit point is further away from our existing assets than necessary, for example, to minimise the costs of the end user's own installation, and where the end user could have reasonably provided us with a location for our exit point closer to our existing assets;
- connections enhanced to cater for specific electrical characteristics of the end user's equipment; and
- multiple exit points for an end user at a single premise.

11.8 Interaction with other customers

In general, we will address applications from customers that we believe may affect other applicants in the date order that we receive them. This is subject to our being satisfied that there is sufficient information to carry out design work.

In making an offer of terms for connection or for the modification of an existing connection, we take into account the existing and committed capacity on the system at the time of the application. The assets (parts of the system / equipment) specified in the offer are not regarded as being committed to the system until the offer has been accepted. You will have a specified period to consider the offer we make to you. During that specific period we may make an offer of terms to a second applicant.

11.9 Expenditure before need

Under the Electricity (Connection Charges) Regulations 2002, as amended, if we install assets in advance of any specified need by you but you derive benefit from these assets, then we reserve the right to charge a proportion of the cost incurred to you. For example, if we commit resources to the construction of system assets, then we will recover a proportion of this cost from any customer who would directly benefit from such modification or additions at a later date provided such date shall be no later than 5 years from the system asset completion date.

11.10 Connections for generators

Where the party seeking connection has installed or intends to install on-site generation capacity and seeks connection to the distribution system for use at any time (either intermittent or continuous), the principles for determining the charge for connection will be in accordance with this statement. Such persons should contact NEDL to discuss the prevailing requirements of the Distribution Code and the Grid Code, which relate to on-site generation.

11.11 Metering, telemetry and data services

Charges for the provision of special metering, metering at a network boundary, telemetry or data processing equipment which are not covered by the charges in our Statement of Charges for Metering and Data services may be applied as connection charges. In the event of such charges being applied we will aim to recover the reasonable costs associated with the specific equipment required.

12 Glossary of terms

The following definitions are intended to assist the reader's understanding of this document.

Act	The Electricity Act 1989 as amended by the Utilities Act 2000.
adoption	Taking ownership of the assets by NEDL.
assets	The electrical plant, equipment and cables used to distribute and supply electricity.
authorised	Applies to a NEDL employee, being recognised by us to have the necessary knowledge and skill to carry out, with the necessary safety and quality, certain tasks associated with the installation of new connections.
Authority	The Gas and Electricity Markets Authority (GEMA) – the regulatory body for the gas and electricity industries established under Section 1 of the Utilities Act 2000.
connection agreement	An agreement between you and us setting out terms and conditions by which we are each bound concerning the provision and use of the connection.
consents	Permissions which we need in accordance with various statutes before we can build or modify an overhead line.
contestable works	Works associated with extension of the electricity distribution system that are open to competition and may be carried out in total either by NEDL or by you or your contractor, to a design and specification approved by NEDL.
customer	You, your company or your agent.
customer's installation	Any structures, equipment, lines, appliances or devices used or to be used by any customer and connected or to be connected directly or indirectly to our system.
de-energisation	The process of disabling the transfer of energy between the distribution system and a customers connection.
disconnection	The permanent removal of a redundant connection.
Distribution Code	The Distribution Code of the Licensed Distribution Network Operators (DNOs) of Great Britain; produced in accordance with Condition 9 of the Licence and approved by the Authority to define the technical aspects and planning criteria of the working relationship between the DNO and all those connected to its Distribution System.
Distribution Licence	The distribution licence granted to NEDL under Section 6(1)(c) of the Act.
distribution system (or system)	The network of plant, equipment and cables owned and operated by NEDL.
domestic premises	Houses, self-contained flats etc where people live, as opposed to business or industrial premises.
easement	A perpetual right negotiated by and granted to us which allows us to install and maintain that equipment under or over private land, normally without restriction.
embedded generator	A generator with a direct connection to a distribution network operator's distribution system, rather than to NGC's transmission system.
energisation	The process of enabling a connection to transfer energy between the distribution system and a customer's connection.
Energywatch	The Gas and Electricity Consumer Council, which is the independent statutory body established under the Utility Act 2000 to protect the interest of gas and electricity consumers.

exit point	A point of connection at which a supply of electricity may flow between our system and the customer's installation or supplier's installation or the distribution system of another person.
extra high voltage or EHV	33,000 volts or higher voltage.
Grid Code	The document produced by NGC in accordance with its Transmission Licence and approved by the Authority to define the technical aspects and planning criteria of the working relationships between NGC and all those connected to its transmission system and including, in certain aspects, embedded generators.
high voltage or HV	6,600 volts or 11,000 volts plus or minus 6% measured between any two phase conductors.
low voltage or LV	230 volts plus 10% or minus 6% measured between the neutral conductor and any phase conductor.
New Roads and Street Works Act or NRASWA	The New Roads and Street Works Act 1991 – the primary legislation that covers the rights and powers for working in the public roads and highways.
non-contestable works	Works that we must carry out for reasons of safety, and to enable us to comply with our legal duty to develop and maintain an efficient, co-ordinated and economical system of electricity supply.
OFGEM	The Office of Gas and Electricity Markets – the support office for GEMA (the Authority).
reinforcement	Any alteration to our existing system designed to enable the system to distribute an increased amount of electricity.
site	A single connection or multiple connections at the same location, as appropriate.
substation	A building or enclosure including the equipment within it, where electricity is controlled, converted or transformed at high voltage or extra high voltage.
supplier	The company from whom you purchase electricity.
tariff support allowance	An allowance in respect of those charges which are to be recovered through the anticipated charges to your supplier for use of our system.
transformer	An item of equipment used for converting electricity from one voltage to another.
use of system charges	The charges that NEDL makes to suppliers for providing the network used to give electricity supplies to customers.

13 Other publications

The following publications and details of where to find them may be of use to those seeking a connection:

- NEDL's Long Term Development Statement - this document is available on the NEDL website.
- Technical Framework Documents (TFD) and NEDL-specific Appendices - these documents are available from NEDL upon request
- Statutory Instrument 2002 Nos 93 and 3232 - The Electricity (Connection Charges) Regulations 2002 and (Amendment) Regulations 2002; and
- Statutory Instrument 2002 No.2665 - The Electricity Safety, Quality and Continuity Regulations 2002.

These two statutory instruments can be found on Her Majesty's Stationery Office website at www.legislation.hmso.gov.uk/stat.htm

14 Version Control

Version	Date	Revision Details	Author
1.1	14/02/05	Revised draft in line with approval letter from Ofgem	Chris Allanson
1.1	09/02/05	Revised draft following minor corrections from Ofgem	Chris Allanson
1.0	16/07/04	First draft for submission to Ofgem	Chris Allanson / Linda Wilson
1.0	07/05/04	Revised draft following Ofgem consultation	Chris Allanson