

LC4A Sub Group

17 October 2006

David Tolley



LC4A Sub Group

■ Terms of Reference

- To discuss and formulate a proposal for a common template for the Statement of Charges required by standard licence condition LC4A

■ Membership

- Felix Mutonono, EDF Energy but representing all DNOs
- Glenn Sheern, E.ON Energy
- Carl Wilkes, Npower Ltd
- David Tolley, RWE Npower (Chairman)
- Colette Schrier, Ofgem
- Mark Askew, Ofgem
- ... but open to all

■ Meetings

- 18 September 2006
- 06 October 2006
- 03 November 2006



Licence Condition 4A

- Statement of Charges for “Use of the System” must:
 - Enable any person can make a reasonable estimate of the charges to which he would become liable
 - Be prepared in accordance with the Use of System methodology (LC4) (where applicable?)

- Charging Methodology must be in accordance with relevant objectives, viz:
 - The obligations that exist under the Act
 - Facilitating competition in generation and supply, and not distorting competition in transmission and distribution
 - Reflecting costs
 - Properly taking account of developments in the Licensees business.

- LC4A prescribes a number of schedules to be included
 - A schedule of charges for the distribution of electricity under use of system (para 2a)
 - A schedule of adjustment factors for distribution losses (para 2b)
 - A schedule of charges for administrative and accounting services (para 2c)
 - A schedule of charges for the provision and maintenance of electrical plant at entry and exit points (para 2d)
 - Information on electricity use of system rebates (if any)



General format under consideration

■ Core Charges

- Generally scope of statements in respect of core charges are same for all DNOs; schedules 2a and 2b
- Proposal to use ENA COG template for charging revisions as future format

■ Explanation of Charges

- Scope of descriptive material under review
- Look-up table linking technical data

■ Ancillary charge

- Energisation and de-energisation of sites
- MPAS transactional and data transfer charges
- Revenue Protection services
- Urgent Metering Services (UMETS)
- Radio Teleswitching



Look-up Tables

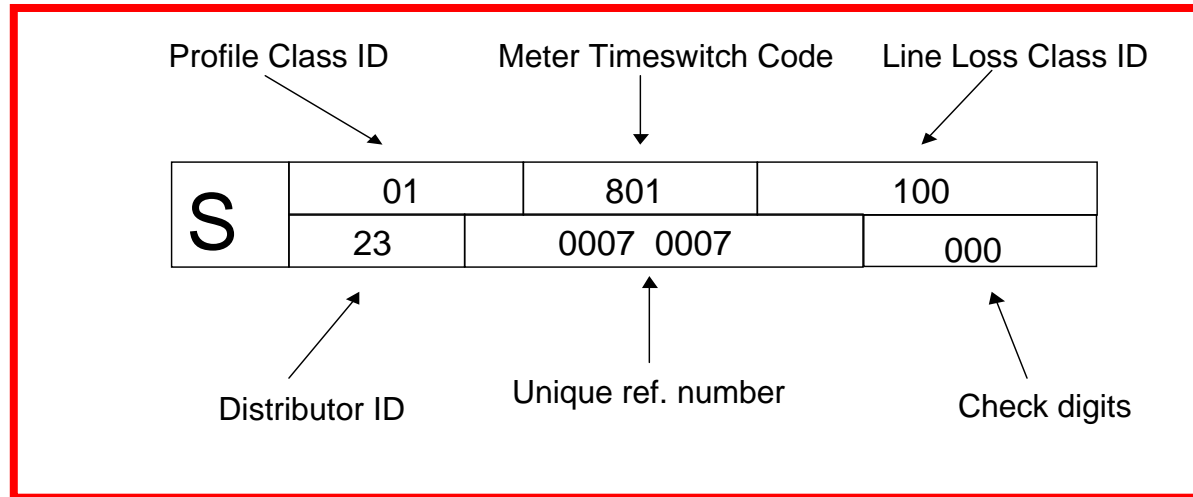

- Required to link charges with time pattern regime (TPR) and system settlement class (SSC)
- Conflict between completeness and comprehension
- Spread sheet based solution being contemplated



Ancillary Charges

- Need to identify purpose of charges. Could be
 - Part of LC4A (paragraph 2d?) obligation, would require methodology to be articulated
 - Included pursuant to some other licence condition
 - For convenience to avoid publishing further statements of charges

- DNOs asked individually to indicate purpose of these charges in their extant Statements

- Ofgem to look at interactions between MPAS, Metering and Use of System charging obligations in distribution licence.

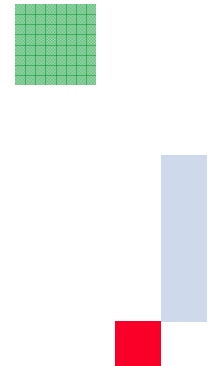

LC4A Sub Group

17 October 2006

David Tolley

