

The background of the slide features a faded, blue-tinted image of a gas meter and an electrical plug. The gas meter is on the left, showing a dial and some text. The electrical plug is at the top left. The main content is centered in a white rounded rectangle with an orange border.

NTS offtake arrangements

Discussion of options

Outline of presentation

1. Outline of options
 - Option 1 – NGT proposal
 - Option 2 – DN booking model
 - Option 3 – Shipper booking model
2. Other issues

1. Outline of options

- Option 1 – NGT proposal
- Option 2 – DN booking model
- Option 3 – Shipper booking model

2. Other issues

Option 1: NGT proposal

- Key features:
 - Based on the current internal planning process
 - DN requests MDQs for all NTS offtake points on basis of 1 in 20 obligation
 - MDQ allocation set by NTS, based on “transparent” process, consistent with its 1 in 20 (firm for 3 years, and indicative for years 4 and 5)
 - NTS also allocates “secondary rights” of diurnal storage and high/low pressures (consistent with MDQ allocation)

Option 1: NGT proposal

Information

Summary:

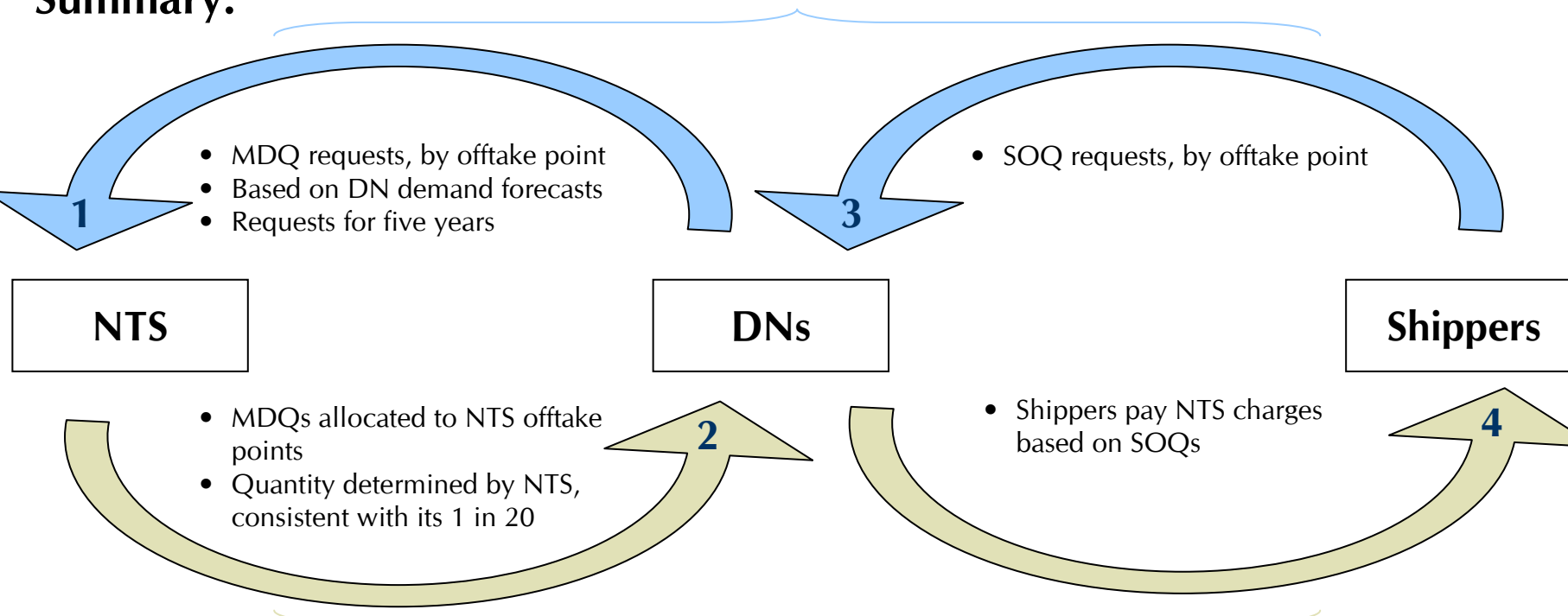

Capacity

Option 1: NGT proposal

Issues:

Robustness

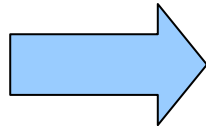

- At present, DNs and NTS have identical commercial objectives
- Codified internal processes may not be robust enough to withstand new commercial tensions

Potential for discrimination

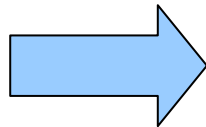

- Possibility of discrimination between:
- IDNs and RDNs
 - DNs and other NTS exit points

Risk of stranded costs

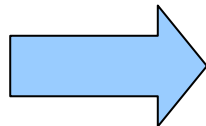

- No charging for MDQ, so no incentive for DNs to limit MDQ requests
- May be an incentive for DNs to overstate true capacity requirements

1. Outline of options

- Option 1 – NGT proposal
- Option 2 – DN booking model
- Option 3 – Shipper booking model

2. Other issues

Option 2: DN booking model

Summary:

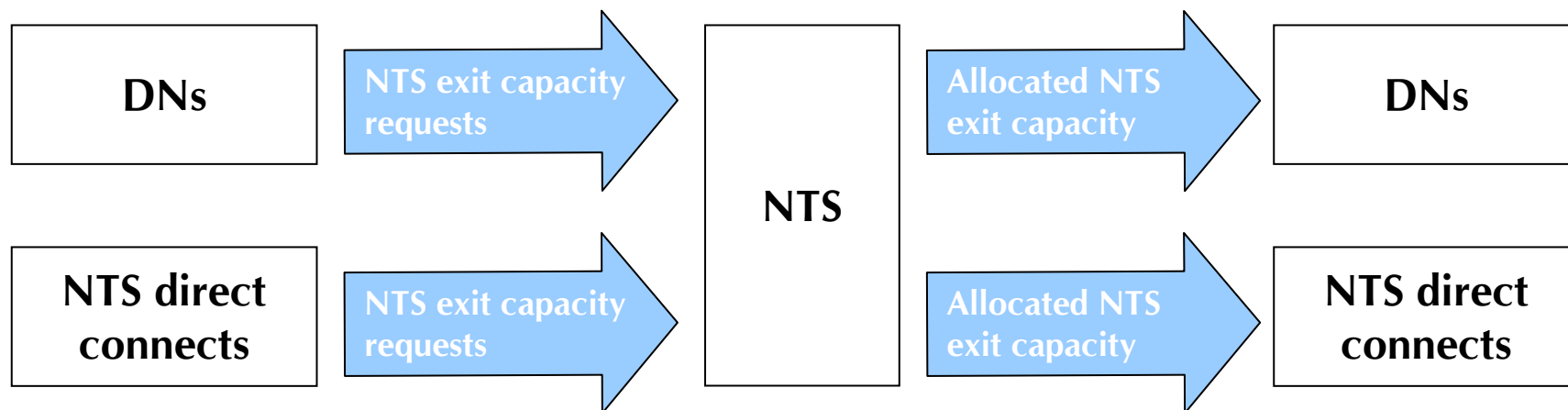

- DN incentivised to request correct quantity of NTS exit capacity
- NTS obliged to meet NTS exit capacity requests
- Overrun charges apply to DN and NTS direct connects

Option 2: DN booking model

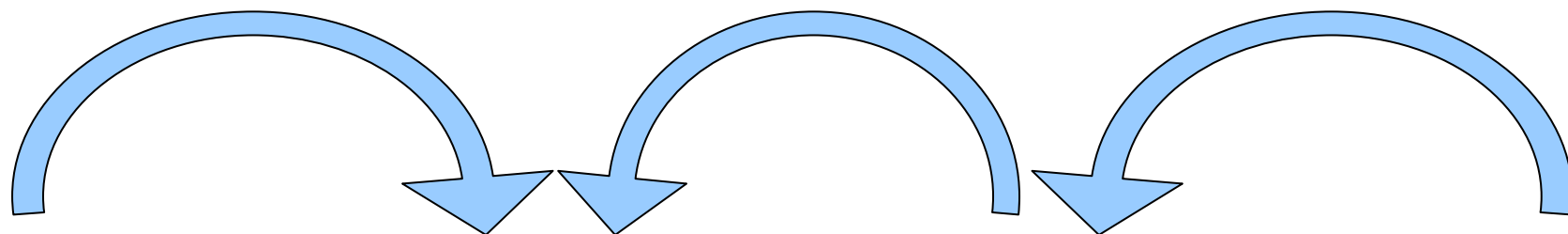

- MDQ requests submitted, by offtake point
- 1 in 20 obligation applies to DN
- Firm requests for three – five years

- SOQ requests submitted, by offtake point

NTS direct connects

NTS

DNs

Shippers

- NTS obliged to contract with DN for level of requested NTS exit capacity

- Exit capacity consistent with SOQs
- Interruption only if firm rights held

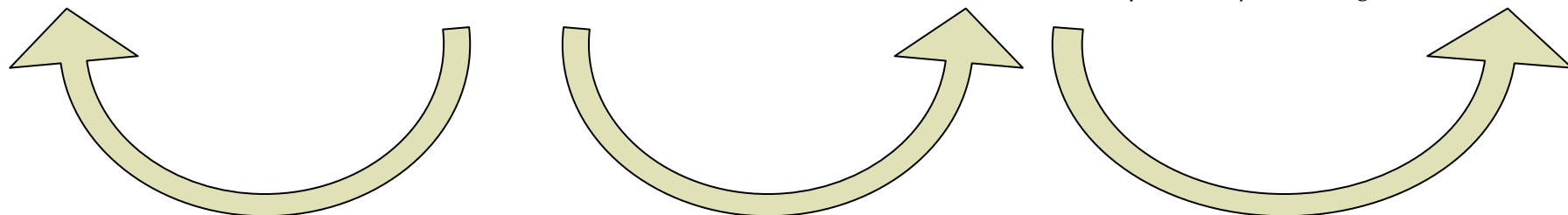

Option 2: DN booking model

NTS exit charges:

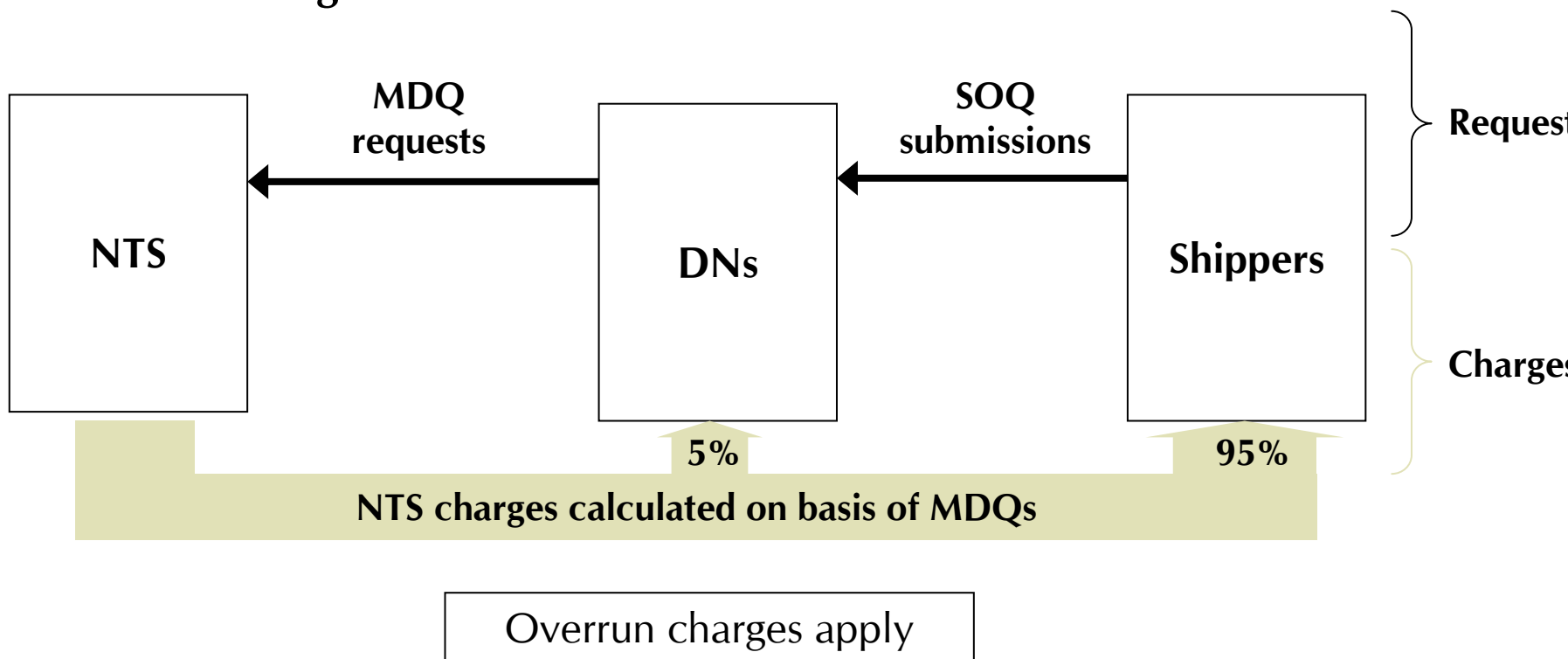

Option 2: DN booking model

- Charges for DN exit capacity
 - DN capacity charged as per current regime
 - DM charges based on submitted SOQs
 - NDM charges based on calculated SOQs, as now
 - Overrun payments also applicable, by shipper

1. Outline of options

- Option 1 – NGT proposal
- Option 2 – DN booking model
- Option 3 – Shipper booking model

2. Other issues

Option 3: Shipper booking model

Overview:

- Central role for shippers in determining MDQs
- No 1 in 20 obligation on network operators
- Shippers determine MDQs and interact directly with NTS to secure NTS exit capacity rights
- Shippers make capacity requests based on customers needs (for DM sites and NDM zones, per DN)
- NTS exit capacity provided to shippers, consistent with requests

Option 3: Shipper booking model

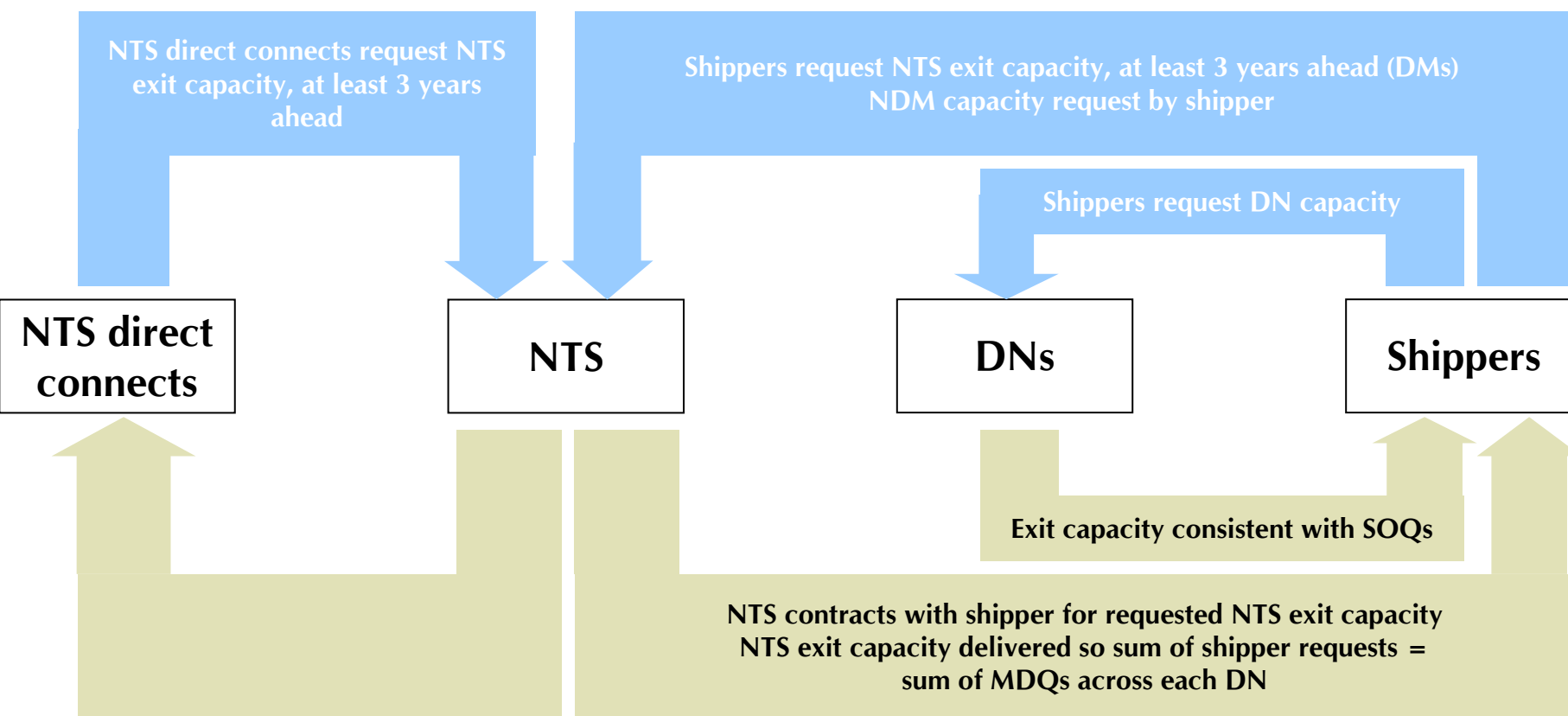

Option 3: Shipper booking model

- Features
 - Shippers request NTS exit capacity (by “Zone”) for up to 5 years ahead. Capacity allocations are “firm” for 3 years ahead (consistent with investment planning process)

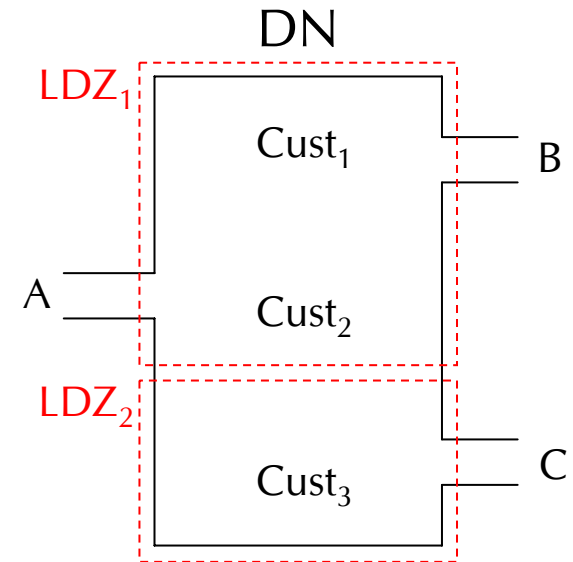

Option 3: Shipper booking model

- Charging for NTS exit capacity:
 - Shipper charges are based upon submitted (firm) capacity requests
 - Long-term charges are visible (through LRMC methodology)
 - Shippers liable for overruns on NTS exit capacity (by zone / LDZ)
- Charges for DN exit capacity
 - DN capacity charged as per current regime
 - Overrun payments also applicable, by shipper

Option 3: Shipper booking model

- Exit capacity from DN
 - Shippers allocated DN capacity based on submitted request
 - DN exit capacity charge for shippers calculated as per current regime
 - Overrun payments also applicable, by shipper

1. Outline of options

- Option 1 – NGT proposal
- Option 2 – DN booking model
- Option 3 – Shipper booking model

2. Other issues

Other issues

- Allocation of capacity in short term
 - Unconstrained, with buy-back by network operator?
 - Constrained capacity allocation (on non-discriminatory basis)?
- Diurnal storage
 - a product traded between networks
 - charged / allocated through similar options to those outlined above?
 - how is pricing determined?
 - how is non-discrimination ensured?
- Pricing of operational elements of capacity provision for all NTS offtake points (e.g. deviations from ramp rates etc.)



ofgem

Promoting choice and value for all
gas and electricity customers