

November 2003

Information and Incentives Project

**Regulatory Instructions and
Guidance version 3**

Executive Summary

This document is version 3 of the Regulatory Instructions and Guidance (RIGs). This version of the RIGs will take effect on and from 1 November 2003. Amendments have been made to Section 3 with respect to the speed of telephone response in accordance with the amendment mechanism set out in Standard Licence Condition 49 of the Electricity Distribution Licence. In drawing up this version of the RIGs, Ofgem has considered responses to the draft versions, which were published in July and September 2003 respectively.

Ofgem has made these changes to the RIGs to:

- ◆ allow for DNOs to report consistently on the speed of telephone response;
- ◆ provide further guidance in this area

Some amendments that were proposed in the July and September draft versions have been revised in the light of respondents' comments. This is discussed further in the covering letter to these RIGs.

Copies of this document and the covering letter are available on Ofgem's website (www.ofgem.gov.uk).

Table of contents

1. Introduction	1
Structure of this document	2
2. Definitions, instructions and guidance for reporting the number and duration of interruptions to supply.....	3
Introduction	3
Information sources.....	3
Definitions of output measures.....	3
Further definitions, instructions and guidance.....	4
Disaggregation of incidents	15
3. Definitions, instructions and guidance for reporting on speed and quality of telephone response.....	19
Introduction	19
Speed of telephone response	19
Quality of telephone response.....	28
4. Definitions, instructions and guidance for monitoring medium term performance.	30
Introduction	30
Definitions.....	31
Instructions and guidance.....	34
5. Required level of accuracy for reporting	36
Introduction	36
6. Reporting arrangements.....	38
Introduction	38
Appendix 1 Purpose of IIP information.....	40
Appendix 2 Formulae for the purposes of reporting	41
Appendix 3 Other formulae.....	46

1. Introduction

- 1.1 Version 3 of the revised Regulatory Instructions and Guidance (RIGs) has been produced in accordance with Standard Licence Condition (SLC) 49 of the electricity distribution licence. The purpose of the RIGs is to provide a framework for the collection and provision of accurate and consistent information from the electricity distribution companies. This is important as it reduces the level of regulatory uncertainty that may otherwise exist. The benefits of improvements in the quality of information should be realised by all those with an interest in the regulation of distribution companies, including customers and their representatives, the regulator and the companies themselves.
- 1.2 The RIGs include definitions and related instructions and guidance for collating “Specified Information” as defined in SLC 49. Where possible Ofgem has specified consistent definitions to apply to all distribution companies. Ofgem is also putting in place an audit framework that will assess whether the information that is collected meets the required levels of accuracy and is consistent with the definitions contained in the RIGs.
- 1.3 Any changes to the RIGs will comply with the change process set out in paragraphs 9 to 11 of the IIP information licence condition. Ofgem recognises that any significant changes to the scope or form of the information that it requests from the distribution businesses could not only increase the regulatory burden but also the perception of regulatory risk. It is Ofgem’s intention to change the scope and form of the information it requests as infrequently as possible, consistent with Ofgem carrying out its duties under the Electricity Act 1989 and the Utilities Act 2000.
- 1.4 Distribution businesses will be expected to have the necessary measurement systems in place by April 2002 for delivering the required levels of accuracy of reporting.

Structure of this document

1.5 The RIGs covers six main areas:

- ◆ definitions, instructions and guidance for collating information on:
 - the number and duration of interruptions to supply and short interruptions to supply – (Section 2);
 - assessing the speed and quality of telephone response – (Section 3); and
 - monitoring medium term performance – (Section 4);
- ◆ specification of the required levels of accuracy for reporting – Ofgem has specified minimum levels of accuracy that must be achieved for the reporting of the number and duration of interruptions to supply (Section 5);
- ◆ reporting arrangements – an outline of the reporting arrangements for IIP; (Section 6); and
- ◆ an outline of the purpose for which Specified Information will be used – Appendix 1;
- ◆ formulae for the purposes of reporting – Appendix 2; and
- ◆ other formulae – Appendix 3.

2. Definitions, instructions and guidance for reporting the number and duration of interruptions to supply

Introduction

2.1 This section sets out definitions and related instructions and guidance for the reporting of:

- ◆ the number of interruptions to supply;
- ◆ the duration of interruptions to supply;
- ◆ short interruptions to supply; and
- ◆ the number of re-interruptions to supply.

Information sources

2.2 Most distribution companies use the National Fault and Interruption Reporting Scheme (NaFIRS) which is administered by the Electricity Association (EA) - or an equivalent system - to collect information on the number and duration of interruptions to supply. For the purpose of reporting under the IIP, companies must use the definitions contained in this document.

Definitions of output measures

2.3 Definitions to be applied for reporting on the number and duration of interruptions to supply, the number of short interruptions to supply and the number of re-interruptions to supply are shown below. Further definitions, instructions and guidance are provided in paragraphs 2.4 to 2.66.

- ◆ **the number of interruptions to supply per year** – the number of customers interrupted per 100 customers per year, where an interruption of supply to customer(s) lasts for three minutes or longer, excluding re-interruptions to the supply of customers previously interrupted during the same incident (see below for further details). It is calculated as:

$$\frac{\text{The sum of the number of customers interrupted for all incidents} * 100}{\text{The total number of customers}}$$

- ◆ **the duration of interruptions to supply per year** - average customer minutes lost per customer per year, where an interruption of supply to customer(s) lasts for three minutes or longer, calculated as:

$$\frac{\text{The sum of the customer minutes lost for all restoration stages for all incidents}}{\text{The total number of customers}}$$

- ◆ **the number of short interruptions to supply per year** – the number of customers interrupted by a short interruption per 100 customers per year, where the initial interruption to supply is restored in less than three minutes , calculated as:

$$\frac{\text{The sum of the number of customers interrupted by short interruptions} * 100}{\text{The total number of customers}}$$

- ◆ **the number of re-interruptions to supply per year** – the number of customers re-interrupted per 100 customers per year, calculated as:

$$\frac{\text{The sum of the number of customers re - interrupted} * 100}{\text{The total number of customers}}$$

Further definitions, instructions and guidance

Customer

- 2.4 Any energised or de-energised entry or exit point to the distribution system, where metering equipment is used for the purpose of calculating charges for electricity consumption. Customers should be identified from Metering Point Administration Numbers (MPANs), such that individual customers are identified at each connection point.
- 2.5 Only one (individual) customer should be identified at each connection point. This means that multiple (or secondary) MPANs which arise due to the type of

“tariff” (or equivalent) and/or metering arrangements, but are associated with a single connection point, should not be counted.

- 2.6 In some cases (e.g. flats), the connection point may be from the distribution system to wiring owned by a landlord or a facilities manager. In such cases, individual customers supplied by such wiring are classed as customers of the distribution system where they are identifiable from MPANs.
- 2.7 The method adopted by companies to identify customers from MPANs shall be agreed in advance with Ofgem. Ofgem will want to ensure that, as far as possible, distribution companies use a consistent method for identifying customers.

Total number of customers

- 2.8 The total number of customers is defined as the total number of customers connected to the company’s distribution network as at 30 September in the relevant reporting year.

Incident

- 2.9 Any occurrence on the distribution system or other connected electricity supply system, which involves a physical break in the circuit upstream of the customers interrupted (or circuit affected), for three minutes or longer, due to automatic or manual operation of switchgear or fusegear, or due to any other open circuit condition, which:
- ◆ results in an interruption of supply to customer(s) for three minutes or longer; or
 - ◆ prevents a circuit or item of equipment from carrying normal load current or being able to withstand “through fault current” for three minutes or longer.
- 2.10 In addition to failures of power equipment, other occurrences classed as an incident include:

- ◆ the unprogrammed isolation of any circuit or item of equipment, energised at power system voltage, which has not been classified as a pre-arranged incident;
- ◆ failures of non-system equipment (e.g. pilot cables, oil and gas alarms, voltage control equipment etc) which result in the disconnection of equipment energised at power system voltage;
- ◆ incorrect operations of protection equipment which result in the disconnection of a circuit energised at power system voltage;
- ◆ failures of protection equipment to operate. This includes incidents where the main protection fails to operate and a fault clearance is initiated by back-up protection or protection at another point on the network;
- ◆ the loss of infeed from other connected systems, including those owned by the National Grid Company/Transmission Companies (in Scotland), other distribution companies and distributed generators, that cause a loss of supply to customers for 3 minutes or longer; and
- ◆ the pre-arranged isolation of any circuit or item of equipment energised at power system voltage that results in loss of supply.

2.11 A further incident must be reported if another incident occurs which affects part of the network and/or customers already affected by an incident. Two or more incidents may then be active concurrently and the number and duration of interruptions and the number of re-interruptions should be calculated accordingly.

2.12 Occurrences that would not lead to an incident are as follows:

- ◆ maintenance outages and malfunctions of non-system equipment (e.g. pilot cables, etc) which do not result in the disconnection of equipment energised at power system voltage;
- ◆ failures and overloads on customers' equipment or another authorised electricity operator's system, which are cleared by the correct operation

of the distribution company's protection and which does not interrupt the supply to other customer(s) of the distribution company; and

- ◆ pre-arranged works affecting single customers for the purposes of meter changes, voltage standardisation, and work on service cables and distributors' fuses.

Unplanned incident on the distribution system

- 2.13 Any incident arising on the licensee's distribution system, where statutory notification has not been given to all customers affected at least 48 hours before the commencement of the earliest interruption (or such notice period of less than 48 hours where this has been agreed with the customer(s) involved).

Pre-arranged incident

- 2.14 Any incident arising from the pre-arranged isolation of any circuit or item of equipment energised at power system voltage that results in loss of supply and where statutory notification has been given to all customers affected at least 48 hours before the commencement of the earliest interruption (or such notice period of less than 48 hours where this has been agreed with the customer(s) involved).
- 2.15 A pre-arranged incident which requires a number of switching operations involving an interruption to supply to customers should be treated as a single incident provided that the outage times are within the period stated on the notification provided to the customer(s).

Incident on other systems

- 2.16 Any incident arising on other connected electricity supply systems which leads to the interruption of supply to the customers of the licensee, including:
- ◆ National Grid Company or Transmission Companies (in Scotland);
 - ◆ distributed generators; and
 - ◆ any other connected systems – which should be identified.

Non-damage incident

- 2.17 A non-damage incident is defined as any unplanned incident where supply can be restored from the same source without the need for the repair of equipment or other intervention.

Incident start

- 2.18 The incident start time is the earlier of the date and time at which:
- ◆ the first report is received of a loss of supply or other abnormality which prevents a circuit or other item of equipment from carrying normal load current or being able to withstand “through fault current” for three minutes or longer; or
 - ◆ the relevant circuit is automatically, deliberately or otherwise disconnected.

Report Received Time

- 2.19 The report received time is the earliest time that a distribution company became aware of a loss of supply, an abnormality or a suspected abnormality. It shall be the earlier of the date and time at which:
- ◆ a customer (or other person) first contacted the distribution company to advise of no-supply, an abnormality or suspected abnormality;
 - ◆ an alarm was received by the distribution company indicating a loss of supply, abnormality or suspected abnormality; or
 - ◆ a distribution company employee or agent identified the existence of a loss of supply, abnormality or suspected abnormality.
- 2.20 For reports that are associated with a loss of supply or other abnormality, which prevents a circuit or other item of equipment from carrying normal load current or being able to withstand “through fault current” for three minutes or longer, the report received time will coincide with the incident start time. For other reports the report received time may precede the incident start time, for example:

- ◆ when deliberate disconnection is undertaken some time after the report is received; or
 - ◆ when some faults are held by arc suppression.
- 2.21 In respect of loss of supply, some companies wait for a second report before initiating action. However, for the purposes of reporting under the IIP the incident start time must be based on the time of the first report received. The date and time of an incident is the time at which the company first becomes aware of the incident by any means.

Incident completion

- 2.22 An incident is considered complete when supplies have been restored from the network to all customers involved in the incident for a period of at least 3 hours. This does not require the restoration of the normal network configuration and open points.
- 2.23 If there is a further loss of supply to some or all of the same customers within 3 hours of the initial supply restoration, this should be counted as a re-interruption. Equally, if there is a further loss of supply to some or all of these customers 3 hours or more after the initial supply restoration then this should be treated as a new incident.
- 2.24 There is a special case where some form of temporary supply arrangement¹ has been used to restore supplies. In this case, if there is a loss of supply to some or all of the same customers within 18 hours of the initial supply restoration in order to connect or disconnect the temporary supply arrangements, then this further loss of supply should be treated as a re-interruption.
- 2.25 In cases where there is a loss of supply to some or all of the same customers within 18 hours of the initial supply restoration because of a failure of the temporary supply arrangement itself, then this should be treated as a re-interruption.

¹ Defined in paragraph 2.36

- 2.26 If, for any reason, supplies to some or all of the same customers are subsequently lost after an 18-hour period of supply restoration via a temporary arrangement, then this further loss of supply should be treated as a new incident.
- 2.27 Where an incident start and completion time/date spans two reporting years, it should be allocated to the year in which the incident started.

Interruption

- 2.28 An interruption is defined as the loss of supply of electricity to one or more customers due to an incident (defined above) but excluding voltage quality abnormalities, such as dips, spikes or harmonics.

Short interruption

- 2.29 Short interruptions are defined as the loss of supply of electricity to one or more customers due to automatic, manual or remote control operation of switchgear or fusegear on the distribution system or other systems, upstream of the customers interrupted, where supply is restored within three minutes.
- 2.30 For the purpose of reporting under the IIP, companies are required to report the total number of short interruptions, and disaggregated number of short interruptions by the following four causes:
- ◆ due to the automatic operation of distribution network switchgear where some or all the customers involved are successfully restored by automatic switching within three minutes of the first interruption;
 - ◆ due to the automatic operation of distribution network switchgear where some or all the customers involved are successfully restored by manual or remote control switching within three minutes of the first interruption. This definition includes only the initial restoration. Further short interruptions during subsequent stages of fault sectionalising are not included;
 - ◆ due to the manual or remote operation of distribution network switchgear for reasons such as deliberate disconnection for operational or emergency reasons; and

- ◆ due to the operation of switchgear on the networks of NGC/Transmission Companies (in Scotland) or other connected systems and distributed generators.
- 2.31 Short interruptions do not need to be disaggregated by voltage or by HV circuit. Where companies make significant use of automatic reclosing devices and automatic switching at the LV level, the number of short interruptions at this voltage level should be included in the appropriate short interruption categories identified above.
- 2.32 In the case of multi-shot reclosing schemes, only one short interruption is to be counted where the successful restoration is achieved by a sequence of multiple operations within a period of three minutes, where these are identifiable. Where the sequence of operations is not identifiable, then a simple count of all operations of automatic reclosing device(s) could be used, excluding those operations recorded elsewhere, e.g. those associated with other incidents or routine switching.
- 2.33 The number of customers interrupted should be identified in the same way as for incidents (i.e. those situations where customers are off supply for three minutes or longer). If a company uses periodic counts of recloser operations to calculate the number of short interruptions then the number of customers interrupted will be based on an estimate of those customers who would have been interrupted, assuming the circuit affected was configured normally, i.e there were no abnormal feeding arrangements.
- 2.34 The dates and times of short interruptions are not required. Where short interruptions are identified from a periodic count of circuit breaker operations the counters should be read annually between 1 January and 31 March to ensure a reasonable approximation to a 12-month total.

Re-interruption

- 2.35 A re-interruption is defined as the loss of supply of electricity to one or more customers for a period of 3 minutes or longer, where those same customers have experienced an interruption during previous restoration stages of the same incident.

Temporary Supply Arrangement

- 2.36 A temporary supply arrangement is the use of temporary connections, temporary disconnections or mobile generation in order to provide temporary restoration of supplies during an incident.

Temporary connection

- 2.37 A temporary connection is a connection (made without using normal switching devices) which is not to become a permanent feature of the distribution system, but which is used solely to provide a temporary restoration of supplies during an incident.

Temporary disconnection

- 2.38 A temporary disconnection is a deliberate break in the continuity of a circuit, which is not to become a permanent feature of the distribution system, but is used solely to facilitate the temporary restoration of supplies during an incident.

Restoration stage

- 2.39 A restoration stage is defined as a stage of an incident, at the end of which supply to some or all customer(s) is restored and/or a circuit or part of a circuit is re-energised, excluding any restoration/re-energisation which is immediately followed by a circuit trip.
- 2.40 Where a customer(s) is temporarily restored for a period of less than three minutes, then calculation of the duration of interruptions to supply should ignore the time for which customers were restored.
- 2.41 There should be no limit to the number of restoration stages for an incident.

Start of a restoration stage

- 2.42 The start of a restoration stage is the date and time at which supply to customer(s) is interrupted and/or a circuit or part of a circuit is de-energised.

End of a restoration stage

- 2.43 The end of a restoration stage is the date and time at which customer(s) have their supply restored and/or a circuit or part of a circuit is re-energised.

Customers involved in a restoration stage

- 2.44 The customers involved in a restoration stage are defined as the customers connected to that part of the distribution network restored in the restoration stage, including restorations from mobile generators and temporary connections.
- 2.45 The number of customers interrupted for single phase and two phase LV faults may be calculated on a pro-rata basis, i.e. $1/3$ or $2/3$ of the total number of customers connected to the LV circuit, or part of circuit, affected. Customers with a three phase LV supply (where these can be identified) are considered to be interrupted when supply is interrupted to one or more of the three phases. Individual customer phase connections do not need to be identified for the purpose of reporting under the IIP. It may be helpful, in terms of the audit process, if companies recorded the number and phases of fuses that have operated in the event of an incident on the LV system.
- 2.46 For HV faults, in the interest of simplicity and consistent reporting, if one phase of a three-phase circuit is disconnected it should be considered that two-thirds of customers connected downstream of the point of disconnection had their supplies interrupted.
- 2.47 Where a connectivity model is in place it should be used consistently to derive the number of customers interrupted on a particular element of the network modelled. Where the section of network involved is a subset of a modelled network element, then the number of customers interrupted may be derived from records or from information available on site.
- 2.48 Customers involved for HV, EHV and 132 kV should take account of the real time changes to 132 kV/EHV/HV network configuration during restoration, which may be identified from a connectivity model.

- 2.49 Customers involved in each restoration stage may be identified from a connectivity model in which customer information is individually linked with the appropriate section of network to which they are connected.
- 2.50 The date and time of interruption and the date and time of restoration must be recorded for each restoration stage. The numbers of customers involved and the elapsed time in each restoration stage will be used to calculate the number and duration of interruptions to supply.

Distribution system

- 2.51 The distribution system is defined as in the standard distribution licence. Transmission activities in Scotland encompass 132 kV electrical line and plant. References to reporting on 132 kV in the RIGs are not applicable to the two Scottish ex-PES distribution companies.

Interruption sequences

- 2.52 An incident may include both a loss of supply of less than 3 minutes duration and a loss of supply of 3 minutes or longer. Under such circumstances, where the loss of supply of less than 3 minutes duration occurs first, it should be reported as a short interruption. Further losses of supply of less than 3 minutes duration during the course of the same incident do not need to be reported.

Updating the connectivity model

- 2.53 It is important that the connectivity model is kept up to date. The accuracy with which the number and duration of interruptions to supply are reported is, in part, determined by the frequency with which the connectivity model is updated. A reasonable timeframe for updating the connectivity model is likely to be within 14 days of the distribution company being formally notified of any permanent changes to the network or customer connections. (For example, a change expected to be in place for at least 28 consecutive days may be regarded as a permanent change). In addition, the numbers of customers in the model could be reconciled with the total number of connected customers on a monthly basis.

Disaggregation of incidents

2.54 It is necessary to collect information on the number and duration of interruptions to supply at a disaggregated level. This will help in comparing performance across distribution companies and could be used for making adjustments within the incentive scheme. There are three types of mutually exclusive disaggregation required. These are :

- ◆ by source;
- ◆ by voltage level; and
- ◆ by HV circuit.

Disaggregation by “source”

2.55 In addition to reporting on the effect on customers of all incidents arising on the distribution system, the number and duration of interruptions to supply arising from the following 5 categories should be separately identified:

- ◆ unplanned incidents on the distribution system, i.e. all incidents *excluding* pre-arranged incidents;
- ◆ pre-arranged incidents on the distribution system;
- ◆ incidents on the systems of the National Grid Company or Transmission Companies (in Scotland);
- ◆ incidents on the systems of distributed generators; and
- ◆ incidents on any other connected systems – which should be identified.

Disaggregation by voltage levels

2.56 All incidents arising on the distribution system should be disaggregated in the following classifications, which are defined in more detail below:

- ◆ 132 kV;
- ◆ Extra High Voltage (EHV) excluding voltages up to and including 22 kV;

- ◆ High Voltage (HV) and voltages up to 22 kV;
- ◆ Low Voltage (LV); and
- ◆ LV Services.

2.57 For the purpose of reporting under the IIP voltage/system boundaries are defined as follows:

132 kV systems

2.58 The "lower boundary" of the 132 kV system should be taken as the supply terminals of the distribution company's customers supplied at 132 kV or the load side terminals of switchgear controlling the secondary (lower voltage) side of 132 kV transformers. If no switchgear exists between the secondary side of the 132 kV transformer and the primary side of an EHV or HV system transformer then the "lower boundary" should be taken as the secondary side terminals of the 132 kV transformer. The lower voltage busbars and their protection equipment at 132 kV/lower voltage substations are NOT included.

2.59 The "upper boundary" of the 132 kV system should be taken as the point at which ownership of the 132 kV circuit or plant becomes the responsibility of the distribution company.

EHV systems

2.60 For the purposes of reporting under the IIP, Extra High Voltage (EHV) includes all voltage levels above 22kV up to but excluding 132kV². The "lower boundary" of EHV systems should be taken as the supply terminals of customers supplied at EHV, and in other situations as the load side terminals of protection equipment connected to the secondary side (lower voltage) of distribution transformers. The "upper boundary" should in general be taken as the busbar side of lower voltage switchgear of transformers whose primary voltage is 132kV or above and whose secondary voltage is EHV. If no secondary switchgear exists, the "upper boundary" should be taken as the secondary side terminals of the transformer. Faults on the system connected to the secondary voltage

² See paragraph 2.51 in relation to the reporting of incidents in Scotland

terminals of the transformer should be reported as EHV faults and not as 132kV faults.

HV systems

- 2.61 For the purposes of reporting under the IIP, High Voltage (HV) includes all voltage levels above 1,000 volts up to and including 22kV. The "lower boundary" of HV systems should be taken as the supply terminals of customers supplied at HV, and in other situations as the load side terminals of the protection equipment connected to the secondary side (lower voltage) of distribution transformers respectively. The "upper boundary" should in general be taken as the busbar side of lower voltage switchgear of transformers whose primary voltage is 132 kV or above and whose secondary voltage is HV. If no secondary switchgear exists, the "upper boundary" should be taken as the secondary side terminals of the transformer; faults on the system connected to the secondary voltage terminals of the transformer should be reported as HV faults and not as 132 kV faults.
- 2.62 In practice companies will normally report and disaggregate by each discrete voltage level in order to report to the above classifications.

LV systems

- 2.63 For the purposes of reporting under the IIP, a Low Voltage (LV) system is one that operates at a nominal voltage of 1000 V or less.
- 2.64 The upper boundary should be taken as the load side terminals of the protection equipment connected to the secondary side (low voltage) of distribution transformers. The lower boundary should be taken as the points of connection associated with LV services.

LV Services

- 2.65 For the purpose of IIP reporting LV Services are defined as the service line from the LV distributing main to the distribution company's protection device situated upon the customer's premises including the joint and associated components connecting the service line to the distributing main. It should be noted that incidents on meters and time-switches and cutouts, including cut out fuse

operations are excluded from reporting under the IIP (even where this results in the operation of a fuse at the distribution company's substation) and the definition of LV Services therefore excludes this equipment.

Disaggregation by HV circuit

- 2.66 The number and duration of interruptions to supply arising on HV systems need to be reported by HV circuit.

3. Definitions, instructions and guidance for reporting on speed and quality of telephone response

Introduction

3.1 This section sets out definitions and related instructions and guidance to be used for the reporting on:

- ◆ the speed of telephone response and other related information; and
- ◆ the information which Ofgem, and its appointed agents, require for undertaking a survey of customers' views of the response that they receive when they contact the distribution company by telephone.

Speed of telephone response

Definition of the specified contact lines

3.2 It is necessary to specify which telephone calls are relevant for measuring the speed of telephone response. All telephone calls received to the following lines should be included:

- ◆ to the "freephone power outage telephone number" (and its equivalents) operated by the distribution company or by its appointed agents (or contractors);
- ◆ to the security and safety enquiry service telephone number (if different from the above) operated by the distribution company or by its appointed agents (or contractors); and
- ◆ to contractors and/or agents of the distribution company who act as an overflow or crisis management facility during peak periods.

3.3 To the extent that companies provide a different emergency telephone number as required by the Electricity Supply Regulation (ESRs), this is not included in the definition of specified contact lines.

Definitions of the required information

- 3.4 Distribution Network Operators (DNOs) are asked to report performance on the speed of telephone response to an agent once a customer has decided that they want to speak to an agent. They are also required to report performance under a number of supporting key measures. These are described below.
- 3.5 Figure A1.1 illustrates the generic telephony system that allows a customer to hold to speak to an agent following a fault message. Figure A1.2 illustrates the generic telephony system that requires a customer to call back on an alternative number to speak to an agent following a fault message.

Figure A1.1 Generic system for call handling where customers hold to speak to an agent following a fault message

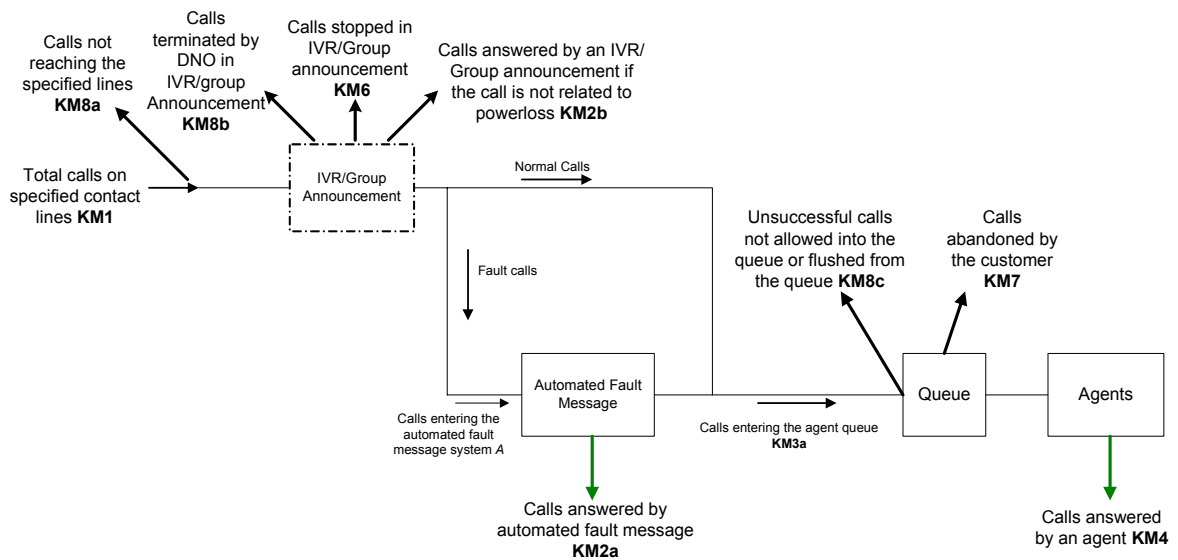
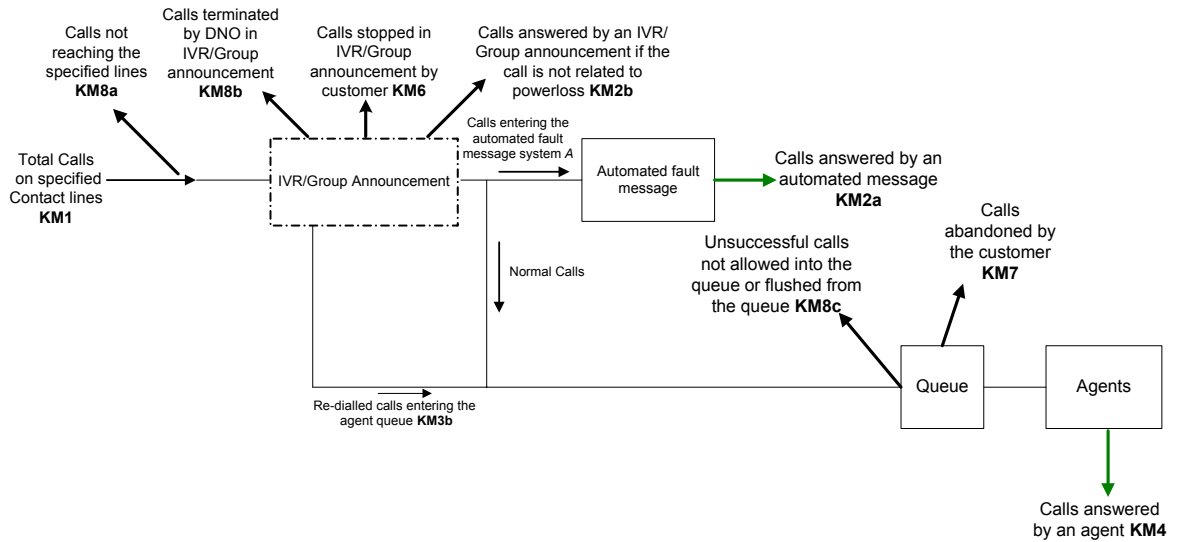

Figure A1.2 Generic system for call handling where customers are required to call back on an alternative number to speak to an agent following a fault message



Key Measures

- 3.6 Each DNO will be required to comply with this requirement on and from 1 November 2003 unless the Authority has, prior to that date and in writing, agreed with that DNO that an alternative date for the implementation of this requirement shall apply to that DNO. The measurement points identified in figures A1.1 and A1.2 should be used for this purpose. These key measures are expanded upon below.

Table A1.1 Explanation of key measures for the reporting template

Key Measure	Definition
KM1	Total calls on the specified lines
KM2 - KM2a - KM2b	Total calls answered by an automated message: Total calls answered by an automated message providing fault details Total calls answered by an IVR/group announcement providing details of alternative contact telephone numbers if the call is not a powerloss call
KM3 - KM3a - KM3b	Total customers waiting to speak to an agent after listening to an automated message providing details of a fault: By holding for an agent By re-dialling on an alternative number
KM4	Total calls answered by an agent
KM5 - KM5a - KM5b - KM5c	Time taken for response by an agent: Total Mean time queuing or holding Maximum time queuing or holding (where possible)
KM6	Total calls ended by the customer in the IVR/group announcement
KM7	Total calls abandoned by the customer in the queue
KM8 - KM8a - KM8b - KM8c	Total number of unsuccessful calls: Total calls not reaching the specified lines Total calls terminated by the DNO during the IVR/group announcement Total calls not allowed into the queue or flushed from the queue

- ◆ **Key Measure 1 – total calls on the specified lines.** Defined as the total number of incoming calls received on the specified lines. In both figures A1.1 and A1.2, the measurement point is *KM1*. This includes those calls to the specified contact lines which do not enter those lines (for example calls receiving an engaged tone).

Some or all of the specified contact lines may be operated by the DNOs' appointed agents or contractors. It is anticipated that each DNO can obtain the necessary information from its agents or contractors on the total calls received on the specified lines. It is also anticipated that the number of calls

that are lost prior to entering the specified contact lines can be obtained. This information is important to demonstrate the total number of customer calls on the specified lines.

- ◆ **Key Measure 2 – total calls answered by an automated message.** Defined as all calls routed to and answered by an automated fault message or a message giving details of alternative contact telephone numbers if the call is not related to a powerloss.

On both of the illustrative figures, the number of calls entering the automated fault message facility should be measured at A. The measurement point for the number of calls answered by an automated message providing fault details is *KM2a*. Measuring this statistic at both the entry and exit point enables an additional audit check, described below.

On both of the illustrative figures, the measurement point for the number of calls answered by an automated message giving details of alternative contact telephone numbers if the call is not related to powerloss is *KM2b*.

- ◆ **Key Measure 3 – total customers waiting to speak to an agent after listening to an automated message providing details of a fault.** Defined as all customer calls waiting to speak to an agent once the customer has decided to speak to an agent following hearing an automated message. This includes:

- (a) those customers that wait for an agent following an automated message, measured at *KM3a* in figure A1.1 and;
- (b) those customers that call back on an alternative number following an automated fault message, measured at *KM3b* in figure A1.2

It is to be expected that DNOs will report either *KM3a* or *KM3b* as zero dependent on the telephony system used. However, where DNOs can report both measures they should do so in the reporting template.

- ◆ **Key Measure 4 – total calls answered by an agent.** Defined as all calls that reach and are answered by an agent. This will include those customers defined in Key Measure 3 and also those customers that reach an agent

under normal conditions. On both of the illustrative figures, calls answered by an agent should be measured at *KM4*.

- ◆ **Key Measure 5 – time taken for response by an agent.** Defined as the total time from when the customer hears a ringing tone to when the call is first answered by an agent:

- (i) for those DNOs' telephony systems that require customers to wait for an agent following an automated message, the time taken is the time from when the customer enters the queue to speak to an agent after the message has finished to when the call is first answered by an agent.

Under normal conditions, the time is from the end of the IVR/group announcement until the call is answered by an agent.

- (ii) for those DNOs' telephony systems where customers are required to dial an alternative number to speak to an agent, the time taken is from when the customer hears the ringing tone of this line to when the call is first answered by an agent, irrespective of whether the DNO has an additional IVR or group announcement on the alternative number.

Under normal conditions, the time is from the end of the IVR/group announcement until the call is answered by an agent.

Where the DNO has an additional IVR/group announcement on the alternative number, the length of this message and its content should be reported as part of the additional narrative accompanying the reported statistics.

DNOs should report the total response time for all relevant telephone calls in a year as *KM5a* and also the mean time for all relevant telephone calls in a year as *KM5b*. This is the total response time for all relevant calls divided by the total number of calls answered by an agent.

Where possible, DNOs should also report the maximum time a customer waited before speaking to an agent as *KM5c*.

- ◆ **Key Measure 6 – total calls ended by the customer in the IVR/group announcement.** Defined as the total number of calls where customers choose to end their call in the IVR/group announcement and should be measured at *KM6* in both illustrative figures.

Ofgem anticipates that each DNO can obtain the necessary information from its appointed agent or contractor where these operate the IVR/group announcement on behalf of a DNO.

- ◆ **Key Measure 7 – total calls abandoned by the customer in the queue.** Defined as calls that are abandoned by the customer in the queue and should be measured at *KM7* in both illustrative figures.
- ◆ **Key Measure 8 – total number of unsuccessful calls.** Defined as the total number of calls that are terminated by the DNO (either by call flushing or call blocking or other similar method) once the customer has called the specified lines.

On both of the illustrative figures, calls that are made to the specified lines but do not enter the specified lines should be measured at *KM8a*. Calls that enter the specified lines but are terminated by the DNO in the IVR/group announcement should be reported as *KM8b*. Calls that enter the agent queue but do not progress to an agent following the call being terminated by the DNO in the queue should be measured at *KM8c*.

Guidance for reporting

- 3.7 It is important that DNOs report on a consistent basis over time, and as such, it is important for Ofgem to set out clearly additional guidance for reporting.
- 3.8 Ofgem requires the information to be reported consistently across the DNOs and has developed an appropriate template for this information to be reported. Each DNO should complete this for each of the key measures identified in table A1.1 above. The reporting template DNOs should use is set out in figure A1.3 below.

- 3.9 DNOs are required to report the information to Ofgem on a monthly basis, fourteen days after the end of each calendar month.

Audit checks

- 3.10 Reporting under the Key Measures allow Ofgem to undertake a simple audit check to ensure that all calls to the specified lines are accounted for. KM6 is included to enable this check. The main audit check is:

$$KM1 = KM2 + KM4 + KM6 + KM7 + KM8 - KM3a$$

Disaggregated audit checks

- 3.11 Further checks are necessary for some of the Key Measures.
- 3.12 For Key Measure 2, it is important that the sum of the calls entering the automated fault messaging system equal the sum of those calls answered. The audit check for KM2a is:

$$KM2a = A$$

- 3.13 For Key Measure 8, it is important that the sum of all calls that are either blocked from entering the specified lines or flushed out of the system are captured. The audit check for KM8 is:

$$KM8 = KM8a + KM8b + KM8c$$

Format of report

- 3.14 DNOs should report the required information required within the relevant timescales in the following format:

Table A1.2 Reporting Template

Key Measure	Definition	Total
KM1	Total calls on the specified lines	
KM2 KM2a KM2b	Total calls answered by an automated message - Total calls answered by an automated message providing fault details - Total calls answered by an IVR/group announcement providing details of alternative contact telephone numbers if the call is not related to powerloss	-
KM3 KM3a KM3b	Total customers waiting to speak to an agent after listening to an automated message providing details of a fault - Waiting for an agent - Re-dialling on an alternative number	-
KM4	Total calls answered by an agent	
KM5 KM5a KM5b KM5c	Time taken for response by an agent (seconds) - Total - Mean - Maximum (where possible)	-
KM6	Total calls ended by the customer in the IVR/group announcement	
KM7	Total calls abandoned by the customer in the queue	
KM8 KM8a KM8b KM8c	Total number of unsuccessful calls - Total calls not reaching the specified lines - Total calls terminated by the DNO during the IVR/group announcement - Total calls not allowed into the queue or flushed from the queue	-

Additional narrative

3.15 In addition to the information specified above for inclusion in the accompanying narrative companies are also required to identify, on an annual basis:

- ◆ the number of temporary customer telephone contact points that are put in place and the reason for their introduction;
- ◆ the length of time each of the contact points was in place; and
- ◆ the number of calls received to each contact point.

- 3.16 In addition companies should also report on the configuration of their telephony systems. Companies are asked to describe the number and configuration of incoming lines linked to lines identified under the categories outlined above - a schematic diagram should be included to explain how the telephony system is set up.
- 3.17 Where companies are unable to provide information on the Key Measures identified above, they should use the accompanying narrative to explain why this is the case and when they will be able to provide the relevant information.

Quality of telephone response

- 3.18 Ofgem intends to undertake a survey of the views of customers of the telephone response that they receive when they contact the distribution company. To undertake this survey, Ofgem (and/or its appointed agents) will require information on the customers that have contacted the distribution companies by telephone.
- 3.19 In order for Ofgem to undertake the survey, distribution companies are required to provide the following information:
- ◆ the telephone number of each person (or customer contact) telephoning either of the following enquiry services/contact lines whose call is answered by a telephone operator (i.e. excluding automated responses):
 - to the freephone power outage telephone number (and its equivalents) operated by the distribution company or by its appointed agents (or contractors);
 - to the security and safety enquiry service telephone number (if different from the above) operated by the distribution company or by its appointed agents (or contractors);
 - ◆ together with, if known, the name of that person, whether that person is a domestic or non-domestic customer and when they telephoned the distribution company.

Customer contact

3.20 In some instances customer information may not be available to the distribution company, including where:

- ◆ customers choose to withhold their telephone number, either verbally or by using a call line identification blocking service (i.e. by pressing 141 before contacting the distribution company);
- ◆ customers refuse to partake in a survey; and
- ◆ where, in consultation with the Data Protection Registrar and distribution companies, Ofgem considers that the provision of information would be a breach of the Data Protection Act.

3.21 In such circumstances the distribution company is not required to submit the customer information outlined above.

4. Definitions, instructions and guidance for monitoring medium term performance

Introduction

- 4.1 This section sets out definitions and related instructions and guidance for the reporting of information that Ofgem requires for monitoring the medium term performance of distribution networks. Ofgem intends to collect information in three main areas, namely:
- ◆ an analysis of fault rates and causes on electrical line and plant and equipment;
 - ◆ a supporting narrative provided by the distribution companies; and
 - ◆ activity based information on the number of “units” replaced of an asset that has been identified as poorly performing and that is the subject of a replacement programme.
- 4.2 It is not Ofgem’s intention to constrain companies’ monitoring and reporting of medium term performance (MTP). The framework for monitoring MTP will develop over time and as such companies could report at a more disaggregated level, and are encouraged to report additional indicators and/or narrative that they consider relevant.
- 4.3 At future price control reviews Ofgem will want to understand the impact of future expenditure (both capital and operating) on MTP.
- 4.4 The requirements for reporting on MTP are outlined below. PB Power (Ofgem’s technical advisors on the initial phase of the IIP) produced a report on monitoring MTP. This is available on Ofgem’s website (www.ofgem.gov.uk). This is for information purposes only and companies are not required to report on the basis of the PB Power document.

Definitions

Reliability

- 4.5 Ofgem intends to monitor the reliability (fault rates) of electrical line and plant and equipment, together with the fault causes. For the purposes of this document reliability is defined as the number of reportable incidents affecting line, plant and equipment expressed as the:
- ◆ number of faults per unit length of circuit classification (per 100 km); and
 - ◆ number of faults per unit of equipment classification (per 1000 units); and
 - ◆ number of service faults per 1000 customers connected at low voltage.
- 4.6 For the purposes of medium term reporting, a fault comprises an unplanned incident or a series of related unplanned incidents each resulting from a single direct cause on the same single item of equipment. In other words, a single failure of the system (including any recurrence) is to be included once only and pre-arranged incidents and incidents on other connected systems are to be excluded.

Required information

- 4.7 For the first year of reporting under the IIP (2001/2), distribution companies are required to provide an historical analysis of reliability and fault causes according to the classifications outlined below. This should be provided for the last five years including for the reporting year 2001/02 (i.e. reports should be submitted in 2002). This will ensure that there is a track record of information going forward for assessing reliability. Distribution companies must also explain any changes that have been made to definitions or measurement over this period that have led to a change in the reported figures.

132 kV, 66 kV and 33 kV circuits and equipment

- 4.8 Fault rates need to be provided according to the following breakdown, i.e. 3 trend lines per voltage level. It should be noted that the total fault rate may exceed the sum of the fault rates for overhead lines and underground cables.

132 kV	66 kV	33 kV
Total (all faults)	Total (all faults)	Total (all faults)
Overhead lines	Overhead lines	Overhead lines
Underground cables	Underground cables	Underground cables

High voltage

Overhead lines and underground cable

- 4.9 All high voltage levels should be aggregated from more than 1 kV up to and including 22 kV, i.e. there should be a single classification for HV. This should be disaggregated by overhead line and underground cable. The fault rates on each should be reported according to the following classification, i.e. 5 trend lines for each.

Overhead line plus pole mounted/structure mounted fusegear, isolators and switch disconnectors	Underground cable (i.e. power cables)
Total (all causes)	Total (all causes)
Weather and environment ³	Weather and environment
Company causes and faulty manufactures	Company causes and faulty manufactures
Unknown or unclassified causes	Unknown or unclassified causes
Third party	Third party

- 4.10 Total fault rates (all causes) in the table above include all fault rates attributed to the relevant class of equipment and will be equal to the sum of the fault rates for the disaggregated causes.⁴

Switchgear and protection systems

- 4.11 Distribution companies should include NaFIRS defined (or equivalent) pole-mounted automatic circuit breakers and automatic sectionalisers and all (automatic or non-automatic) ground-mounted switchgear and protection and control equipment classifications. Distribution companies should report all

³ The classification "Weather and Environment" should include incidents relating to "Birds, Animals and Insects".

⁴ If companies provide information at a more disaggregated level it must reconcile with the classifications in the table.

faults for this aggregated category, i.e. 1 trend line. For the purposes of calculating the fault rate for switchgear and protection systems, the number of protection units should be excluded from the denominator.

Transformers and reactors

- 4.12 Distribution companies should report all faults for both transformers and reactors, disaggregated by ground- and pole-mounted equipment, i.e. 2 trend lines.

Low Voltage

- 4.13 For LV overhead mains reporting, faults on surface wiring mains and pole-mounted switchgear/fusegear should be included. . For LV underground mains, faults on ground-mounted switchgear/fusegear should also be included. Fault rates should be reported by cause as follows, i.e. 5 trend lines for each. The denominator should exclude the length of service cables.

LV Overhead line	LV Underground main
Total (all causes)	Total (all causes)
Weather and environment ⁵	Weather and environment
Company causes and faulty manufactures	Company causes and faulty manufactures
Unknown or unclassified causes	Unknown or unclassified causes
Third party	Third party

- 4.14 Total fault rates (all causes) in the table above should sum to all fault rates attributed to the relevant class of equipment and will be equal to the sum of the fault rates for the disaggregated causes.

⁵ The classification “Weather and Environment” should include incidents relating to “Birds, Animals and Insects”

Services – overhead and underground

- 4.15 All service equipment should be aggregated, and should include:
- ◆ overhead service line and equipment;
 - ◆ surface wiring service;
 - ◆ underground service cable and equipment; and
 - ◆ any other service line, cable and equipment (excluding unmetered services).
- 4.16 Companies are required to report the total number of faults on all service equipment, which does not need to be disaggregated by cause, i.e. there will be 1 trend line for service faults.

Instructions and guidance

- 4.17 In addition the following points need to be considered:
- ◆ the fault cause classifications outlined above are those used in NaFIRS. Where distribution companies do not report to NaFIRS, equivalent classifications will need to be agreed with Ofgem;
 - ◆ no distinction is made between damage and non-damage faults although companies are free to report separately on damage and non-damage faults; and
 - ◆ volumes of equipment, length of circuits (excluding services) should be based on a count at 30 September in the relevant reporting year.

Narrative

- 4.18 In addition to the reporting of reliability, distribution companies are also required to provide a supporting narrative. Ofgem would like to publish the narrative in some form. This may help spread best practice through the industry. If distribution companies feel that any section of the narrative should remain confidential it should be clearly marked and an explanation provided as to why this is the case. Particular issues that the narrative should cover, include:

- ◆ an explanation of the trends observable from the reliability information – to include actions taken to improve reliability or identify and replace/improve deteriorating assets, together with a prediction of future performance; and
- ◆ an explanation of any adverse trends in the reliability of sub-asset groups not covered by the RIGs but collected by the distribution company as part of its asset management strategy.

Activity based information

- 4.19 Companies are required to provide some activity based information such as on the number of different assets types replaced, repaired, refurbished or maintained during the year. This should focus on assets which a distribution company has identified as a poorly performing asset type and where it has put in place a replacement or refurbishment programme. The distribution company should provide the number and proportion of the poorly performing asset replaced, repaired, refurbished or maintained each year and how this compares with the envisaged programme. Any differences to the envisaged programme should be explained.
- 4.20 As explained above, Ofgem will want to understand the impact of future expenditure (both capital and operating) on medium term performance, including on replacement or refurbishment programmes across a range of assets, and not solely those that are poorly performing.

5. Required level of accuracy for reporting

Introduction

5.1 Ofgem is concerned that information used to implement the incentive scheme is sufficiently accurate to enable comparisons to be made over time and if appropriate between companies. Ofgem has specified minimum levels of accuracy for the reporting of:

- ◆ the number of interruptions to supply – at both the Low Voltage (LV) level and the overall level; and
- ◆ the duration of interruptions to supply – at both the Low Voltage (LV) level and the company level.

5.2 In addition distribution companies are also required to estimate the accuracy with which they report short interruptions to supply.

Required levels of accuracy – number and duration of interruptions to supply

5.3 The table below specifies the minimum levels of accuracy required for the reporting of the number and duration of interruptions to supply. Distribution companies are required to meet both the overall and the LV minimum levels of accuracy. Meeting one of the required levels of accuracy is not sufficient to satisfy the requirements set out in the IIP licence condition.

	Minimum overall level of accuracy (%)	Minimum level of accuracy for LV system interruptions(%)
Number of interruptions to supply	95	90
Duration of interruptions to supply	95	90

Reporting of accuracy levels for short interruptions to supply

5.4 Distribution companies are required to indicate the estimated accuracy of the reporting of short interruptions to supply. This should include a statement on the method used to measure short interruptions and how the estimated level of

accuracy has been assessed. Ofgem's appointed auditors will provide an assessment on the reasonableness of the estimate and whether in their view it has been achieved.

6. Reporting arrangements

Introduction

- 6.1 It is important that robust arrangements are put in place for the reporting of information required under the IIP. This section sets out the reporting arrangements that Ofgem expects to apply in each reporting year. Different arrangements apply for the provision of customer details for the purpose of Ofgem undertaking a survey of customers' views of the telephone response they receive when they contact the distribution company.

Ofgem's role in reporting and the requirements on distribution companies

- 6.2 The normal reporting year for the provision of information required under the IIP will be from 1 April to 31 March of the relevant year. Ofgem expects to publish the RIGs at least one month in advance of the relevant reporting year, normally in February. At the same time Ofgem will also provide the distribution companies with standard templates that should be used for the reporting of IIP information. Any changes to the RIGs will have been consulted on for a period of time in accordance with the IIP licence condition. Where these changes do not relate to information included in the incentive scheme or the required level of accuracy the consultation period will not be less than 28 days.
- 6.3 Distribution companies will normally be required to provide the information required under the IIP at the end of the reporting year and by no later than 30 April. This is the earliest that information can be requested for submission. Ofgem could specify a later date if it considers that it is appropriate. Ofgem recognises that companies will be making changes to measurement systems over the course of the reporting year 2001/02 and as such has decided that the information for this reporting year should be submitted by 31 May 2002. Once the distribution companies have submitted the information to Ofgem, it would expect its appointed auditors to undertake an audit of the information over the course of the summer of the relevant year.

6.4 The table below sets out the key dates for a normal IIP reporting year.

Date	Output
November	Ofgem publishes draft version of RIGs for consultation.
February	Ofgem publishes final version of RIGs and templates to apply for the next reporting year.
1 April	Reporting year begins.
31 March	Reporting year ends.
30 April	Distribution companies submit IIP information to Ofgem.
Summer	Ofgem undertakes audit of IIP information.
Autumn	Ofgem publishes report on distribution companies' performance

Arrangements for the provision of customer information

6.5 In order for Ofgem's appointed agents to undertake a survey of customers' views on the telephone response that they receive when they contact the distribution company, it is necessary for the companies to provide Ofgem (or its appointed agents) with customer information on a regular basis. The information that must be provided is outlined in Section 3 and should be submitted within 4 normal working days of the end of the week in which the customer contacted either of the specified enquiry services. For these purposes the end of the week is defined as the Friday in the week in which the customer contacted the distribution company and normal working days exclude Saturday and Sunday.

6.6 The most appropriate arrangements for submitting this information needs to be agreed with the distribution companies, although Ofgem's preference is for this to be done in electronic form.

Appendix 1 Purpose of IIP information

1.1 The table below sets out the purpose for which the specified information in the IIP information licence condition will be used and which is described in detail in this document. It does not specify how this information will be used in the incentive scheme..

Information	Purpose	
	Incentive scheme	Other
a) Number and duration of interruptions		
Number of interruptions to supply of less than three minutes (short interruptions), included disaggregated by "cause"		Yes
Number of interruptions to supply of more than three minutes	Yes	
Duration of interruptions to supply of more than three minutes	Yes	
Number and duration of interruptions to supply of more than three minutes disaggregated by:		
◆ source;	Yes	Yes
◆ voltage level; and		Yes
◆ HV circuit.		Yes
Aggregate number of re-interruptions to supply		Yes
b) Speed and quality of telephone response	Yes	
Customer information, including the telephone number of the caller; the time of the call; the name of the caller and whether they are a domestic/non-domestic customer	Yes	
c) Medium Term Performance		
Aggregate number and cause of faults on specified classes/types of electrical plant/line		Yes
Statement on the asset management strategy of the licensee		Yes
Statement of the reasons for any increase/decrease in the number of faults		Yes

Appendix 2 Formulae for the purposes of reporting

This annex sets out formulaic expressions for:

- ◆ the number of interruptions to supply in the relevant year t (excluding re-interruptions); and
- ◆ the duration of interruptions to supply in the relevant year t .

Definitions

Cl_t = the number of interruptions to supply in the relevant year t , **excluding re-interruptions**

CML_t = the duration of interruptions to supply in the relevant year t , **including re-interruptions**

i = an unplanned incident on the distribution system

j = a pre-arranged incident on the distribution system.

k = an incident on a transmission system such as the systems of the National Grid Company or Transmission Companies in Scotland in Scotland

l = an incident on an distributed generator's system

m = an incident on any other connected system

r = a restoration stage in any incident i, j, k, l, m

t = relevant year (that financial year for the purposes of which any calculation falls to be made)

TC_t = total connected customers in the relevant year t

TR_{rit} = the restoration time of restoration stage r of an unplanned incident i in the relevant year t .

TR_{rjt} = the restoration time of restoration stage r of a pre-arranged incident j in the relevant year t .

TR_{rkt} = the restoration time of restoration stage r of an incident k on NGC's system or a Transmission Company's system in Scotland in the relevant year t.

TR_{rit} = the restoration time of restoration stage r of an incident l on a distributed generator's system in the relevant year t.

TR_{rmt} = the restoration time of restoration stage r of an incident m on any other connected system in the relevant year t.

TI_{rit} = the interruption time prior to the restoration time of restoration stage r of an unplanned incident i in the relevant year t.

TI_{rjt} = the interruption time prior to the restoration time of restoration stage r of a pre-arranged incident j in the relevant year t.

TI_{rkt} = the interruption time prior to the restoration time of restoration stage r of an incident k on NGC's system or a Transmission Company's system in Scotland in the relevant year t.

TI_{rit} = the interruption time prior to the restoration time of restoration stage r of an incident l on a distributed generator's system in the relevant year t.

TI_{rmt} = the interruption time prior to the restoration time of restoration stage r of an incident m on any other connected system in the relevant year t.

and:

ND_{rit} = Number of customers interrupted in restoration stage r of an unplanned incident i in the relevant year t, **excluding** re-interruptions to supply

ND_{rjt} = Number of customers interrupted in restoration stage r of a pre-arranged incident j in the relevant year t, **excluding** re-interruptions to supply

ND_{rkt} = Number of customers interrupted in restoration stage r of an incident k on NGC's system or a Transmission Company's system in Scotland in the relevant year t, **excluding** re-interruptions to supply

ND_{rit} = Number of customers interrupted in restoration stage r of an incident l in on a distributed generator's system in the relevant year t, **excluding** re-interruptions to supply

ND_{mt} = Number of customers interrupted in restoration stage r of an incident m on any other connected system in the relevant year t, **excluding** re-interruptions to supply

NN_{rit} = Number of customers interrupted in each restoration stage r of an unplanned incident i in the relevant year t, **including** re-interruptions to supply

NN_{ijt} = Number of customers interrupted in restoration stage r of a pre-arranged incident j in the relevant year t, **including** re-interruptions to supply

NN_{rkt} = Number of customers interrupted in restoration stage r of an incident k on NGC's system or a Transmission Company's system in Scotland in the relevant year t, **including** re-interruptions to supply

NN_{rlt} = Number of customers interrupted in each restoration stage r of an incident l on a distributed generator's system in the relevant year t, **including** re-interruptions to supply

NN_{rmt} = Number of customers interrupted in restoration stage r of an incident m on any other connected system in the relevant year t, **including** re-interruptions to supply

Formulae

CI_t is the number of interruptions to supply per year in the relevant year t and is derived from the following formula: $CI_t = CIA_t + CIB_t + CIC_t + CID_t + CIE_t$

where

CIA_t is the number of interruptions from unplanned incidents on the distribution system in the relevant year t and is derived from the following formula:

$$CIA_t = \frac{\left(\sum_i \sum_r ND_{rit} \right) * 100}{TC_t}$$

CIB_t is the number of interruptions from pre-arranged incidents on the distribution system in the relevant year t and is derived from the following formula:

$$CIB_t = \frac{\left(\sum_j \sum_r ND_{rjt} \right) * 100}{TC_t}$$

CIB_t is the number of interruptions arising from incidents on the systems of the National Grid Company or Transmission Companies in Scotland in the relevant year t and is derived from the following formula:

$$CIC_t = \frac{\left(\sum_k \sum_r ND_{rkt} \right) * 100}{TC_t}$$

CID_t is the number of interruptions arising from incidents on the systems of distributed generators in the relevant year t and is derived from the following formula:

$$CID_t = \frac{\left(\sum_l \sum_r ND_{rlt} \right) * 100}{TC_t}$$

CIE_t is the number of interruptions arising from incidents on any other connected systems in the relevant year t and is derived from the following formula:

$$CIE_t = \frac{\left(\sum_m \sum_r ND_{rmt} \right) * 100}{TC_t}$$

Each of the terms, CIA_t, CIB_t, CIC_t, CID_t and CIE_t should be separately identified.

CML_t is the duration of interruptions to supply in the relevant year t and is derived from the following formula:

$$CML_t = CMLA_t + CMLB_t + CMLC_t + CMLD_t + CMLE_t$$

CMLA_t is the duration of interruptions from unplanned incidents on the distribution system in the relevant year t and is derived from the following formula:

$$CMLA_t = \frac{\sum_i \sum_r (NN_{rit} * (TR_{rit} - TI_{rit}))}{TC_t}$$

CMLB_t is the duration of interruptions from pre-arranged incidents on the distribution system in the relevant year t and is derived from the following formula:

$$CMLB_t = \frac{\sum_j \sum_r (NN_{rjt} * (TR_{rjt} - TI_{rjt}))}{TC_t}$$

CMLC_t is the duration of interruptions arising from incidents on the systems of the National Grid Company or Transmission Companies in Scotland in the relevant year t and is derived from the following formula:

$$CMLC_t = \frac{\sum_k \sum_r (NN_{rkt} * (TR_{rkt} - TI_{rkt}))}{TC_t}$$

CMLD_t is the duration of interruptions arising from incidents on the systems of distributed generators in the relevant year t and is derived from the following formula:

$$CMLD_t = \frac{\sum_l \sum_r (NN_{rlt} * (TR_{rlt} - TI_{rlt}))}{TC_t}$$

CMLE_t is the duration of interruptions arising from incidents on any other connected systems in the relevant year t and is derived from the following formula:

$$CMLE_t = \frac{\sum_m \sum_r (NN_{rmt} * (TR_{rmt} - TI_{rmt}))}{TC_t}$$

Each of the terms, CMLA_t, CMLB_t, CMLC_t, CMLD_t and CMLE_t should be separately identified.

Appendix 3 Other formulae

This annex sets out formulaic expressions for:

- ◆ the number of short interruptions to supply in the relevant year t (excluding re-interruptions); and
- ◆ the number of re-interruptions to supply in the relevant year t .

Definitions

RI_t = the number of interruptions to supply in the relevant year t , **including re-interruptions**

n = a short interruption due to the automatic operation of distribution network switchgear where some or all of the customer involved are successfully restored by automatic switching within three minutes of the first interruption

o = a short interruption due to the automatic operation of distribution network switchgear where some or all of the customers involved are successfully restored by manual or remote control switching within three minutes of the first interruption

p = a short interruption due to the manual or remote operation of distribution network switchgear for reasons such as deliberate disconnection for operational or emergency reasons

q = a short interruption due to the operation of switchgear on the networks of NGC/Transmission Companies (in Scotland) or other connected systems and distributed generators.

SI_t = the number of short interruptions to supply in the relevant year t .

NS_{nt} = Number of customers interrupted by a short interruption in category n in the relevant year t .

NS_{ot} = Number of customers interrupted by a short interruption in category o in the relevant year t .

NS_{pt} = Number of customers interrupted by a short interruption in category p in the relevant year t.

NS_{qt} = Number of customers interrupted by a short interruption in category q in the relevant year t.

Formulae

SI_t is the number of short interruptions to supply per year in the relevant year t and is derived from the following formula:

$$SI_t = SIA_t + SIB_t + SIC_t + SID_t$$

where:

SIA_t is the number of short interruptions in the relevant year t due to the automatic operation of distribution network switchgear where some or all of the customer involved are successfully restored by automatic switching within three minutes of the first interruption and is derived from the following formula:

$$SIA_t = \frac{\left(\sum_n NS_{nt} \right) * 100}{TC_t}$$

SIB_t is the number of short interruptions in the relevant year t due to the automatic operation of distribution network switchgear where some or all of the customers involved are successfully restored by manual or remote control switching within three minutes of the first interruption and is derived from the following formula:

$$SIB_t = \frac{\left(\sum_o NS_{ot} \right) * 100}{TC_t}$$

SIC_t is the number of short interruptions in the relevant year t due to the manual or remote operation of distribution network switchgear for reasons such as deliberate disconnection for operational or emergency reasons and is derived from the following formula:

$$SIC_t = \frac{\left(\sum_p NS_{pt} \right) * 100}{TC_t}$$

SID_t is the number of short interruptions in the relevant year t due to the operation of switchgear on the networks of NGC/Transmission Companies (in Scotland) or other connected systems and distributed generator and is derived from the following formula:

$$SID_t = \frac{\left(\sum_q NS_{qt} \right) * 100}{TC_t}$$

Each of the terms, SIA_t, SIB_t, SIC_t and SID_t should be separately identified.

RI_t is the number of re-interruptions to supply in the relevant year t and is derived from the following formula:

$$RI_t = RIA_t + RIB_t + RIC_t + RID_t + RIE_t$$

where:

RIA_t is the number of re-interruptions in the relevant year t from unplanned incidents on the distribution system and is derived from the following formula:

$$RIA_t = \frac{\left(\sum_i \sum_r (NN_{rit} - ND_{rit}) \right) * 100}{TC_t}$$

RIB_t is the number of re-interruptions in the relevant year t from pre-arranged incidents on the distribution system and is derived from the following formula:

$$RIB_t = \frac{\left(\sum_j \sum_r (NN_{rjt} - ND_{rjt}) \right) * 100}{TC_t}$$

RIC_t is the number of re-interruptions in the relevant year t arising from incidents on the systems of the National Grid Company or Transmission Companies in Scotland and is derived from the following formula:

$$RIC_t = \frac{\left(\sum_k \sum_r (NN_{rkt} - ND_{rkt}) \right) * 100}{TC_t}$$

RID_t is the number of re-interruptions in the relevant year t arising from incidents on the systems of distributed generators and is derived from the following formula:

$$RID_t = \frac{\left(\sum_l \sum_r (NN_{rlt} - ND_{rlt}) \right) * 100}{TC_t}$$

RIE_t is the number of re-interruptions in the relevant year t arising from incidents on any other connected systems and is derived from the following formula:

$$RIE_t = \frac{\left(\sum_m \sum_r (NN_{rmt} - ND_{rmt}) \right) * 100}{TC_t}$$