

# Feed-in Tariffs (FIT)

[www.ofgem.gov.uk/fits](http://www.ofgem.gov.uk/fits)

Version 16.0 | 03 Apr 23

## Guidance for Licensed Electricity Suppliers

### Overview

This document sets out guidance for Licensed Electricity Suppliers on their duties under the Feed-in Tariffs (FIT) scheme. It provides details of the processes, procedures and interactions to enable effective administration of the FIT scheme.

This guidance is not intended to be a definitive technical or legal guide to the FIT scheme.

### Context

On 1 April 2010 the government introduced the FIT scheme. The scheme was aimed at encouraging the uptake of small scale renewable and low carbon technologies up to a Total Installed Capacity of 5MW in Great Britain (GB). The scheme requires certain licensed electricity suppliers to pay eligible installations for the generation and export of renewable and low carbon electricity. On 1 April 2019, the scheme closed to new applications, subject to certain conditions.

Installations using solar photovoltaic (PV), wind, hydro and anaerobic digestion technologies up to 5MW – and fossil fuel-derived combined heat and power up to 2kW can receive FIT payments, if all eligibility requirements are met.

The FIT scheme, introduced by the Department of Energy and Climate Change (DECC), is administered by the Gas and Electricity Markets Authority (the Authority), which is assisted in its day-to-day functions by the Office of Gas and Electricity Markets (Ofgem).

### Associated Documents

- Conditions 33 and 34 of the [Standard Conditions of Electricity Supply Licences](#):
- [The Feed-in Tariffs Order 2012 \(As Amended\)](#)
- [The Feed-in Tariffs \(Closure, etc\) Order 2018](#)
- [The Feed-in Tariffs \(Amendment\) \(Coronavirus\) \(No. 2\) Order 2020](#)

## Contents

<b>Guidance for Licensed Electricity Suppliers .....</b>	<b>1</b>
<b>Overview .....</b>	<b>2</b>
<b>Context .....</b>	<b>2</b>
<b>Associated Documents .....</b>	<b>2</b>
<b>Contents .....</b>	<b>3</b>
<b>Executive Summary .....</b>	<b>8</b>
Purpose of this document.....	8
The Feed-in Tariffs scheme .....	8
<b>1. Introduction .....</b>	<b>9</b>
The Feed-in Tariffs scheme .....	9
Administration of the FIT scheme.....	10
Enforcement.....	10
Updates to guidance.....	10
<b>2. The roles of Licensed Electricity Suppliers and Ofgem in the FIT scheme .....</b>	<b>12</b>
General Principles .....	12
Annual FIT Notification .....	12
Notification .....	12
Exiting the FIT scheme .....	13
Obligations to Offer FIT Services.....	14
Responsibilities of FIT licensees in the FIT scheme .....	15
Role of Ofgem in the FIT scheme .....	16
<b>3. Deployment caps .....</b>	<b>20</b>
What are deployment caps.....	20
Tariff rate and eligibility date.....	22
<b>4. Eligibility and Accreditation .....</b>	<b>25</b>
Closure of the scheme and eligibility .....	25
Basic Eligibility Criteria .....	25
Site.....	27
Definitions for Solar PV Installations.....	30

Use of batteries and storage devices .....	31
Combining FIT and Grants.....	32
Accreditation .....	37
Community Energy Installations and School Installations .....	40
Ofgem Powers relating to accredited FIT Installations .....	44
<b>5. Additional requirements for solar PV .....</b>	<b>46</b>
Microgeneration Certification Scheme (MCS) applications and the Energy Efficiency Requirement .....	46
Reviewing applications and EPCs when the Energy Efficiency Requirement applies .....	51
Extensions .....	55
Multiple buildings .....	55
ROO-FIT Community Energy/School Installations .....	56
Multi-installation tariffs (PV only) .....	56
<b>6. Registration of Eligible Installations .....</b>	<b>61</b>
Verification of accreditation details .....	61
Nominated recipient .....	66
Meter details .....	67
Export status.....	68
Confirmation of registration.....	69
Statement of FIT terms .....	69
Failure to agree a statement of FIT terms .....	71
Actions Ofgem may take against accredited FIT Installations .....	72
Extension Rules and additional capacity .....	74
Switching.....	77
<b>7. FIT payments.....</b>	<b>80</b>
Eligibility Date .....	80
Eligibility Period .....	82
Nominated Recipient .....	83
Tariff Rates .....	83
FIT Payments .....	85

Calculation of Generation Payment.....	90
Calculation of Export Payment .....	91
Reducing, Recouping and Withholding FIT Payments .....	92
Biennial Verification of meter readings.....	93
<b>8. Modifications to accredited installations.....</b>	<b>102</b>
Decommissioning .....	102
Extensions and reductions.....	102
Generating equipment .....	103
Other modifications .....	103
Moving FIT Accredited Installations .....	103
Re-allocating Capacity to Another (Second) MPAN.....	104
Changes to MCS Certificates.....	104
<b>9. Levelisation Process .....</b>	<b>109</b>
General Principles .....	109
Periodic Levelisation .....	113
Annual Levelisation .....	116
<b>10. Managing Levelisation Fund Shortfalls .....</b>	<b>120</b>
Introduction .....	120
Shortfalls in the Levelisation Fund .....	120
Shortfalls in the Levelisation Fund (Mutualisation not Triggered).....	122
Shortfalls in the Levelisation Fund (Mutualisation Triggered) .....	122
Making a Mutualisation payment.....	122
Mutualisation distribution .....	123
Late Mutualisation Payments .....	123
Mutualisation: Impact on Levelisation .....	123
<b>11. Dispute Resolution .....</b>	<b>125</b>
Disputes Within the FIT scheme.....	125
<b>12. Appendices .....</b>	<b>128</b>
<b>Appendix 1 – Solar PV Multi-installation Declarations and EER Exemption Template</b> .....	<b>129</b>

Multi-installation Declaration .....	129
Multi-installation Declarations.....	130
<b>Appendix 2 – Solar PV Declaration (Change to the FIT Generator or Nominated Recipient) .....</b>	<b>134</b>
<b>Appendix 3 – Statement of FIT Terms.....</b>	<b>136</b>
Statement of FIT Terms.....	136
<b>Appendix 4 – Best Practice for non-AMR Biennial Meter Verification – Physically Reads (Verification Method One) .....</b>	<b>140</b>
Visits to sites.....	140
Time of visits.....	140
Leave cards.....	140
Pre-arranged visits.....	140
ROO-FIT (over 50kW DNC PV/Wind and all AD/Hydro installations) .....	140
Communication .....	141
Contractual Arrangements .....	141
Notification to Ofgem of withholding of payments .....	141
<b>Appendix 5 – Best Practice for AMR Biennial Meter Verification – Use of Historical Data (Verification Method Two).....</b>	<b>142</b>
Preparing for verification.....	142
Conducting the verification.....	142
Notification to Ofgem of withholding of payments .....	143
<b>Appendix 6 – Best Practice for AMR Biennial Meter Verification – Audit of System (Verification Method Three).....</b>	<b>144</b>
Preparing for verification.....	144
Scope for auditing of AMR systems.....	144
<b>Appendix 7 – Best Practice for non-AMR Biennial Meter Verification – Generator-Submitted Photographic Evidence (Verification Method Four) .....</b>	<b>146</b>
The photograph .....	146
When to not use photographic evidence.....	146
Notification to Ofgem of withholding of payments .....	147

<b>Appendix 8 – Recommended Methodology for Calculating Electricity Supply Data</b>	<b>148</b>
Introduction .....	148
Levelisation submissions .....	148
<b>Appendix 9 – Degression</b>	<b>152</b>
Default Degression Mechanism .....	152
Contingent Degression Mechanism .....	152
<b>Appendix 10 – Reporting on deployment caps</b>	<b>153</b>
How we monitor deployment caps .....	153
Reporting .....	153
Recycling of un-used capacity .....	154
<b>Appendix 11 – Metering Regulations</b>	<b>156</b>
<b>Appendix 12 – Continuity of Payments for FIT Generators</b>	<b>157</b>
Background .....	157
Continuity of FIT Payments Direction .....	157
Notification of a CoFPD event .....	158
Data Regarding FIT Installations .....	158
Informing Customers and FIT Generators .....	159
Requests from FIT Generators .....	159
Transfer Process .....	160
Transferring FIT installations .....	160
Informing New Customers of a Licensee’s FIT Status and Retention of Data .....	161
Application Dates for MCS-Certified Installations .....	161
<b>Appendix 13 – FIT licensee Request for Ofgem Investigation</b>	<b>163</b>
<b>Appendix 14 – Exiting the scheme – Written notification form</b>	<b>167</b>
<b>Appendix 15 – Quarterly Biennial Meter Verification Process</b>	<b>168</b>
<b>Appendix 16 – Glossary</b>	<b>170</b>

### Executive Summary

#### Purpose of this document

This document sets out guidance for Licensed Electricity Suppliers on their duties under the Feed-in Tariffs (FIT) scheme. It provides details of the processes, procedures and interactions to enable effective administration of the FIT scheme.

#### The Feed-in Tariffs scheme

The Feed-in Tariffs (FIT) scheme is an environmental programme aimed at promoting widespread uptake of a range of small-scale low carbon electricity generation technologies. The FIT scheme requires certain Licensed Electricity Suppliers to pay fixed tariffs to micro and small renewable and micro-CHP generators for electricity generated and exported to the National Grid. The FIT scheme policy and tariff rates are set by the Department of Energy Security and Net Zero (formally the Department of Business, Energy and Industrial Strategy), but the scheme is administered by FIT licensees and Ofgem.

This document provides details on the processes, procedures and interactions to enable the delivery of the FIT scheme. It also provides guidance on what Licensed Electricity Suppliers are required to do in order to comply with:

- conditions 33 and 34 of the Standard Conditions of Electricity Supply Licences (“the SLCs”) as amended, and
- the Feed-in Tariffs Order 2012 (“the FIT Order”), and all Amendment Orders associated therewith.

Where an application is made for the accreditation of an installation before 1 December 2012, to qualify for FIT payments that installation must comply with the eligibility criteria, as prescribed by the FIT Order 2010 and Schedule A to Standard Licence Condition 33.

Where an application is made for the accreditation of an installation after 1 December 2012, to qualify for FIT payments that installation must comply with the eligibility criteria, as prescribed by the FIT Order 2012 and Schedule A to Standard Licence Condition 33.

The FIT scheme closed on 1 April 2019. Subject to the rules described in chapter 4, no applications made on or after 1 April 2019 will be eligible for accreditation on the scheme.

All Licensed Electricity Suppliers are required to declare their FIT status annually and take part in Periodic and Annual Levelisation processes (the means by which costs are distributed equally amongst suppliers).



## 1. Introduction

### Chapter summary

Here you can find out about Ofgem's role in the FIT scheme and information about the scheme.

### The Feed-in Tariffs scheme

1.1 The Renewable Energy Strategy, published in July 2009, set out the government's intention to put appropriate incentives in place for different aspects of the low carbon energy sector. The government envisaged that the FIT scheme would encourage deployment of additional small-scale low carbon electricity generation, particularly amongst those who have not traditionally engaged in the electricity market.

1.2 Sections 41 and 43 of the Energy Act 2008 contain powers for the introduction of the FIT scheme in Great Britain to incentivise renewable electricity installations. Under section 41(1) of that Act, the Secretary of State is given the power to modify Standard Licence Conditions (SLCs) and industry codes for the purpose of establishing or making arrangements for the administration of the FIT scheme. Under section 43(3) of the Act, the Secretary of State may confer functions involving the administration of the FIT scheme on Ofgem.<sup>1</sup>

1.3 The FIT scheme launched on 1 April 2010. Its introduction meant that a number of changes had to be made to the Renewables Obligation (RO) to provide transitional arrangements for existing and new generating stations.

1.4 The FIT scheme closed to new applications from 1 April 2019, subject to the conditions described in chapter 4.

1.5 The Electricity Act 1989, the Energy Act 2008, the FIT Order and SLCs provide the legal framework for the scheme.

1.6 This document is procedural guidance around the administration of the FIT scheme. It sits below the obligations, powers and duties that arise in connection with the FIT Order and the SLCs. In the event of an inconsistency between the FIT Order and the SLCs, the FIT Order prevails.

---

<sup>1</sup> Ofgem is the office of GEMA and 'Ofgem' & 'GEMA' are used interchangeably.

### Administration of the FIT scheme

1.7 Ofgem administers certain functions in relation to the FIT scheme. For example, we are responsible for:

- The granting of ROO-FIT preliminary and full accreditation.
- The registration of community energy and school installations.
- Assessing the fuel classification and sustainability information of AD installations.
- Management of the Central FIT Register (CFR).
- The administration of deployment caps and degression.
- Managing the levelisation process.

1.8 FIT licensees are responsible for managing the MCS application process and making FIT payments to generators/nominated recipients. FIT licensees play a key customer-facing role as the main contacts of the FIT scheme.

1.9 This document explains our responsibilities in administering the FIT scheme and sets out what Licensed Electricity Suppliers are expected to do to comply with the provisions in the SLCs.

1.10 At all times, the onus is on the Licensed Electricity Suppliers to ensure that they comply with the SLCs. This document is not intended to provide legal advice on how the FIT Order and SLCs should be interpreted. It is published in accordance with Article 31 of the FIT Order 2012.

### Enforcement

1.11 Any requirement placed on Licensed Electricity Suppliers under the SLCs is a “relevant condition” for the purposes of “Section 25(8)” of the Electricity Act 1989. Ofgem may use its enforcement powers under the Electricity Act 1989, if it has grounds to believe that a Licensed Electricity Supplier is contravening or is likely to contravene a relevant condition. Such action may be by way of an order for securing Licensed Electricity Supplier compliance with the relevant condition. Where a Licensed Electricity Supplier has contravened or is contravening a relevant condition, Ofgem may take action by the imposition of a penalty.<sup>2</sup>

### Updates to guidance

1.12 This guidance replaces the ‘Feed-in Tariffs: Guidance for Licensed Electricity Suppliers (Version 15)’.

---

<sup>2</sup> Please refer to Chapter 2 for further information about compliance powers.

1.13 The following chapter has been updated to reflect the Government decision on scheme cost exemptions<sup>3</sup>.

- **9. Levelisation Process**
  - Market share contribution

1.14 The following chapters have been updated to reflect changes to policy on installing replacement generating equipment that was previously part of an accredited installation.

- **4. Eligibility and Accreditation**
  - Basic eligibility criteria
- **8. Modifications to accredited installations**
  - Moving FIT Accredited Installations

---

<sup>3</sup> [Feed in Tariffs and Contracts for Difference: proposals relating to Guarantees of Origin - GOV.UK \(www.gov.uk\)](https://www.gov.uk/government/consultations/feed-in-tariffs-and-contracts-for-difference-proposals-relating-to-guarantees-of-origin)

## 2. The roles of Licensed Electricity Suppliers and Ofgem in the FIT scheme

### Chapter summary

The respective roles of Licensed Electricity Suppliers and Ofgem within the FIT scheme. It includes the annual FIT notification process and information on how Ofgem will monitor Licensed Electricity Suppliers' compliance and maintain the Central FIT Register.

### General Principles

2.1. As provided for in the Energy Act 2008 and SLCs, only Licensed Electricity Suppliers can be FIT licensees.

2.2. Since 1 August 2012, Licensed Electricity Suppliers have been defined as Mandatory FIT licensees if they have at least 250,000 domestic customers on 31 December of the immediately preceding FIT year. These licensees are obligated to register and make FIT payments to certain eligible generators.

2.3. Licensed Electricity Suppliers with fewer than 250,000 domestic customers can elect to register and make FIT payments to certain eligible generators. These licensees are classed as Voluntary FIT licensees and are required to remain in the FIT scheme for the duration of the FIT year (1 April - 31 March) in which they enter. When determining the number of customers in this context, 'domestic customer' means a customer supplied or requiring to be supplied with electricity at domestic premises.

### Annual FIT Notification

2.4. By 14 February of each FIT year, all Licensed Electricity Suppliers must notify Ofgem whether they will be a Mandatory FIT licensee, a Voluntary FIT licensee or a non-FIT licensee for the FIT year starting on 1 April following the FIT notification. Please see Appendix 16 for definitions of these terms.

### Notification

2.5. The notification needs to include the number of domestic customers on the previous 31 December and the number of domestic customers of any affiliates related to the Licensed Electricity Supplier on that date. Under the SLCs, an "affiliate" is: a) a holding company, b) a subsidiary, or c) a subsidiary undertaking of a holding company, as defined in the Companies Act 2006.

2.6. All Licensed Electricity Suppliers will receive a notification declaration for the FIT scheme to be completed and returned by 14 February. It is the responsibility of the licensee to submit this information by the deadline.

### Exiting the FIT scheme

2.7. Mandatory FIT licensees are not able to withdraw from participating in the FIT scheme.

2.8. Mandatory FIT licensees, whose circumstances alter such that they no longer satisfy the definition of a Mandatory FIT licensee, shall remain in the FIT scheme as a Mandatory FIT licensee until the later of the following 31 March, its next FIT Notification or a period of 6 weeks.

2.9. Any Mandatory FIT licensee who ceases to be a Mandatory FIT licensee and does not elect to become a Voluntary FIT licensee is required to notify all FIT generators to which it makes FIT payments that it will not be continuing to operate as a FIT licensee. They are required to give at least 6 weeks' written notice to generators of their intention to cease to act as a FIT licensee.

2.10. Voluntary FIT licensees who decide to withdraw from participation in the FIT scheme shall:

- Notify Ofgem of this decision.
- Continue their existing obligations as a Voluntary FIT licensee under the FIT scheme until the later of the date that its next FIT notification is due; or, the end of the FIT Year in which it gave notice to Ofgem of its decision; or, the expiry of the 6 weeks' written notice it is required to give to generators to which it makes payments (see Figure 1 below).
- Notify the FIT generators to whom they make FIT payments of the change in status. The notification must be executed as soon as reasonably practicable, and in any event no later than 6 weeks prior to the change. The written notice (see Appendix 14) to generators to which it makes payments shall indicate:
  - the date when their participation in the FIT scheme will terminate
  - the date when their FIT payments to the generators will cease
  - the agreed switch date
  - the consequences of the change to the FIT generators
  - the FIT generator's responsibility to identify a new FIT licensee and to initiate the switching process as soon as possible after receiving the written notice

- All FIT Licensees have a duty to facilitate the switching of a FIT Generator from one FIT Licensee to another and to ensure that the switching process is managed effectively without having an impact on FIT payments.

**Figure 1: Timeline for Voluntary FIT licensees withdrawing from the FIT scheme**

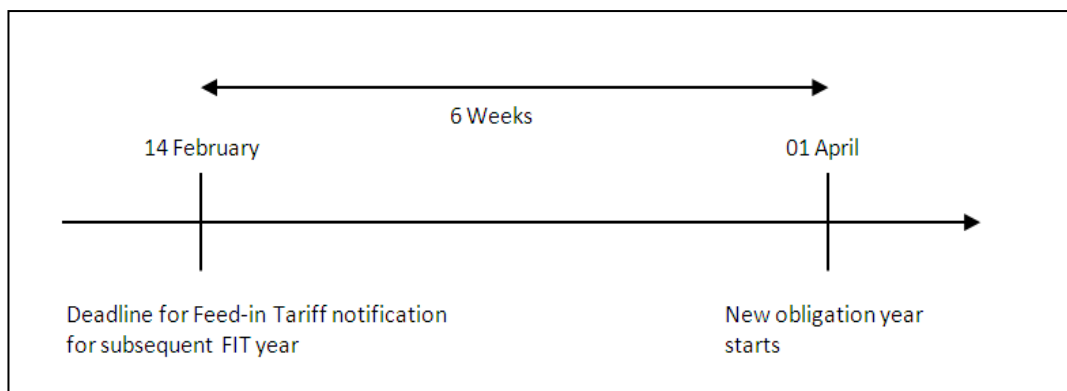

### Obligations to Offer FIT Services

#### Mandatory FIT licensee

2.11. A Mandatory FIT licensee is obligated, when approached, to register and make FIT payments to:

- Its own electricity supply customers.
- An electricity supply customer of a Licensed Electricity Supplier who is not a Mandatory FIT licensee.
- A generator with an Eligible Installation on a site situated off grid.

2.12. Notwithstanding its obligation, a Mandatory FIT licensee is free to register and make FIT payments to any eligible generator it chooses to offer FIT services to.

#### Voluntary FIT licensee

2.13. Once it has opted to become a FIT licensee, a Voluntary FIT licensee is obligated, when approached, to register and make FIT payments, to eligible micro-generators (ie with a declared net capacity of 50kW or less) and who are an electricity supply customer of the Voluntary FIT licensee.

2.14. Notwithstanding its obligation, a Voluntary FIT licensee is free to register and make FIT payments to any eligible generator it chooses to offer FIT services to.

2.15. Where a Voluntary FIT licensee has accepted an application, it is obliged to make payments to the corresponding generator (or nominated recipient) provided the generator

meets the relevant scheme criteria. Where the generator was initially an electricity supply customer of the Voluntary FIT licensee and has since switched import supplier, the Voluntary FIT licensee is still obliged to process FIT payments for that generator unless the generator requests to switch FIT licensee.

### **Licensed Electricity Supplier Not Offering FIT**

2.16. Licensed Electricity Suppliers cannot offer FIT services unless they either notify Ofgem that they are a Mandatory FIT licensee or notify Ofgem that they are electing to become a Voluntary FIT licensee.

2.17. If approached by a generator for the provision of FIT services, Licensed Electricity Suppliers who are neither a Mandatory nor a Voluntary FIT licensee should inform the generator that they do not provide FIT services and direct the generator towards the list of FIT licensees maintained by Ofgem<sup>4</sup>.

### **Responsibilities of FIT licensees in the FIT scheme**

2.18. Mandatory and Voluntary FIT licensees are responsible<sup>5</sup> for:

- Assessing, determining and registering MCS-scale applications for accreditation on the CFR including:
  - a) Taking all reasonable steps to support the process of MCS-certified registration, including verifying that an application for MCS accreditation relates to an installation that is eligible for the FIT scheme and that the information provided by the applicant is accurate.
  - b) Determining the site of an eligible installation where an application for MCS-certified registration is made.
  - c) Assessing applications for MCS accreditation against the Energy Efficiency Requirement and multi installation tariff.
  - d) Submitting details in relation to Eligible Installations (both MCS FIT accredited and ROO-FIT accredited) onto the Ofgem CFR in a timely manner.

---

<sup>4</sup> The list can be found on Ofgem's website - <http://www.ofgem.gov.uk/FITs>

<sup>5</sup> Please refer to the SLCs for the full list of responsibilities of FIT Licensees. Relevant links are provided on the Ofgem website ([www.ofgem.gov.uk/FITs](http://www.ofgem.gov.uk/FITs)) and also on the Department for Energy Security and Net Zero website: (<https://www.gov.uk/government/organisations/department-for-energy-security-and-net-zero>)

- Taking all reasonable steps to ensure the data entered into the CFR is accurate and up-to-date, and, if necessary, updating and amending the CFR with new information including the submission of change request forms.
- Agreeing statements of FIT terms with FIT generators.
- Acquiring generation and/or export meter readings in a timely manner, ensuring generators are made aware of what is required of them in terms of providing meter readings, and taking all reasonable steps to satisfy themselves, as the FIT Licensee, that these meter readings are reasonable and within expected tolerances.
- Verifying generation and/or export meter readings at least once every two years.
- Calculating and making FIT payments in accordance with the information held on the CFR and taking all reasonable steps to ensure that FIT generators and nominated recipients only receive FIT payments which they are eligible for.
- Ensuring that FIT generators registered with the FIT licensee for both their electricity supply and FIT payments are not discriminated against unreasonably in terms of changing electricity supplier or the price paid for electricity supply.
- Fully cooperating with the process of levelisation, including the provision of accurate data to Ofgem.

2.19. When providing information to a FIT generator (whether in writing, by electronic display or verbally) in relation to the FIT scheme, FIT licensees must take all reasonable steps to ensure the information:

- Is complete and accurate.
- Is capable of being easily understood by the FIT generator.
- Does not mislead the FIT generator.
- Is otherwise fair, transparent, and appropriate and delivered in a professional manner both in terms of content and in terms of how it is presented (with more important information being given appropriate prominence).

### Role of Ofgem in the FIT scheme

2.20. Ofgem has a number of statutory duties and functions to perform in respect of the FIT scheme. These include:



- Assessing and determining applications for preliminary accreditation in respect of wind and solar PV installations over 50kW DNC and up to 5MW TIC and all installations using hydro or AD technology up to 5MW TIC.
- Assessing and determining applications for accreditation in respect of wind and solar PV installations over 50kW DNC up to 5MW TIC and all installations using hydro or AD technology up to 5MW TIC; known as ROO-FIT accreditation.
- Assessing and determining applications for pre-registration of “community energy installations” and “school installations”.
- Allocating tariff codes and (where applicable) rates.
- Calculating and publishing FIT payment rate tables.
- Establishing and maintaining the Central FIT Register.
- Calculating, periodically and annually, the FIT contribution of each licensee, receiving Levelisation Payments from all FIT licensees, and making Levelisation Payments.
- Monitoring Licensed Electricity Suppliers' compliance with the requirements of Section C of the Electricity Supply Licence and the FIT Order.
- Publicly reporting on Licensed Energy Suppliers' compliance.
- Publicly reporting the total number of FIT generators registered on the Central FIT Register, and the number of MWh generated and FIT Payments made under the FIT.
- Monitoring ongoing participation of participants as appropriate.
- Reporting annually to the Secretary of State for Business, Energy and Industrial Strategy. Reporting on FIT licensee compliance, FIT Payments made, amount of electricity generated under the scheme and number of participants.
- Determining whether a deployment cap in a tariff period has been reached.
- Determining whether an adjustment is required to the level of a deployment cap in a tariff period.
- Reporting quarterly the deployment under caps for the previous quarter.

### **Monitoring Licensed Electricity Suppliers' compliance with the FIT scheme**

2.21. To ensure that controls are in place across the scheme and that FIT licensees are meeting their obligations, Ofgem continually monitors the compliance of suppliers with the SLCs and FIT Order. As part of this function, Ofgem will undertake reviews and inspections of the

processes Licensed Electricity Suppliers have in place to demonstrate compliance and that the information held by FIT licensees is accurate.

2.22. FIT licensee audits are intended to focus on areas of risk within the scheme whilst ensuring that broader guidance requirements are complied with. Audits will include aspects relating to:

- FIT Application Assessment and Documentation
- Information Systems
- FIT Payments and Levelisation
- Internal Audits/Assurance Projects.

2.23. Ofgem, or a contractor working on its behalf, will seek to carry out audits annually; however, Ofgem will continually review the state of the scheme and may adjust the frequency and scope dependent on risk factors.

### **Fraud Prevention**

2.24. Ofgem has a zero tolerance approach to fraud. Our Counter Fraud team undertakes activities to detect, prevent and deter fraudulent activity across the scheme. We expect all licensees to work closely with them to ensure a collaborative and targeted approach.

2.25. We expect FIT licensees to proactively mitigate the risk of fraud within the scheme. Ways in which this can be achieved should include, but are not limited to:

- Identifying potential fraud risks and putting in place mitigating actions/processes within their own organisation.
- Processes to verify generation and/or export meter readings, and detect any abnormal readings.
- Methods for selecting which sites with automatic meter readers are to be physically read as part of the biennial meter readings verification.
- Checks to confirm ownership of the installation, generator and nominated recipient details and verification of supporting documentation.
- Maintaining processes for handling, investigating and the prompt and accurate reporting of suspected fraud to us.
- Suitable senior management oversight and review of fraud risks, activity, and reporting.

2.26. FIT licensees should submit their fraud prevention strategies to our Counter Fraud team (counterfraud@ofgem.gov.uk) no later than 30 September each year. We will work closely with suppliers and may offer feedback to help ensure their strategies are appropriate, effective and robust. Additionally, we will share any areas of best practice we identify with all licensees.

2.27. FIT licensees' strategies should provide sufficient evidence to demonstrate the steps taken to eliminate fraud.

2.28. All FIT licensees are invited to attend our regular FIT fraud prevention forum. At the forum we discuss common fraud risks and issues across the scheme and identify ways to drive best practice together.

2.29. FIT licensees should promptly report all instances of suspected fraud to our Counter Fraud team.

2.30. FIT licensees must ensure their own investigations into suspected fraud are thorough and completed in a timely manner. If there are any questions regarding their investigation plan, approach or results, suppliers should contact our Counter Fraud team.

### **CFR and Data Protection**

2.31. Ofgem is required to establish and maintain the CFR. The data to be placed on the CFR will include data on FIT generators and accredited FIT installations. The CFR will be used primarily by FIT licensees and Ofgem for the administration of the FIT scheme. In addition, Ofgem has a statutory obligation to publish certain statistical information from the CFR and is a public authority for the purposes of legislative obligations relating to the publication of information.

2.32. The CFR is being maintained by Ofgem in accordance with the data protection principles under the Data Protection Act 2018, and general restrictions on disclosure of information under section 105(1) of the Utilities Act 2000. Terms and conditions of use of the CFR are listed on the register. These enshrine the principles of confidentiality, which are to be upheld by all parties at all times.

2.33. FIT licensees will be expected to include a statement<sup>6</sup> on the privacy, use and sharing of data in the Statement of FIT Terms.

---

<sup>6</sup> An example of such a statement could be: 'I consent to the disclosure of the enclosed information to one or more FIT Licensees, the Gas and Electricity Markets Authority (Ofgem) and ministerial departments of the government and devolved administrations for retention and use by them for all purposes connected with administering, auditing, reporting on and performing statistical analysis on the Feed-in Tariff scheme for the duration of that scheme.'

## 3. Deployment caps

### Chapter summary

This chapter explains about deployment caps and how this impacts licensees, generators and our administration of the scheme.

### What are deployment caps

3.1. On 8 February 2016, quarterly deployment caps were introduced into the FIT scheme for all solar PV, wind, hydro, and anaerobic digestion installations.

3.2. All affected generators that applied for full ROO-FIT accreditation or had MCS certificates issued on or after the start of the pause to the FIT scheme on 15 January 2016 are subject to the deployment caps.

3.3. On 1 April 2017, six monthly deployment caps were also introduced for micro CHP.

3.4. Deployment caps place limits on the total capacity that can receive a particular tariff rate in a particular tariff period.<sup>7</sup> Separate deployment caps are in place for each technology and tariff band.<sup>8</sup>

3.5. Under deployment caps applications are allocated to a tariff period in the following way:

- For ROO-FIT installations – these are ordered by the date and time that the application was received by Ofgem.
- For MCS installations – these are ordered by the date and time that the installation's MCS certificate was first issued.

3.6. Once a cap has been reached for a technology or tariff band, no further installations are eligible to receive the tariff rate applicable for that band in that tariff period.

3.7. If a deployment cap is reached within a tariff period the tariff in the next, and all subsequent, tariff periods will degress by a further 10% in addition to the default degression. This is known as contingent degression. Further information is provided in Appendix 9.

---

<sup>7</sup> A 'tariff period' for all technologies with the exception of micro CHP, is a period of three months starting on 1 April, 1 July, 1 October, 1 January (except for the first tariff period which is 8 February until 31 March 2016). For micro CHP installations, a tariff period is a period of six months, starting from 1 April 2017.

<sup>8</sup> The deployment cap limits are available in Tables 3A – 3D of the Licence Modifications. For the latest version of the Licence Conditions, follow this link: <https://www.ofgem.gov.uk/licences-codes-and-standards/licences/licence-conditions>, and under the 'Electricity' heading, click 'Electricity Supply Standard Licence Conditions'.

3.8. FIT tariff rates<sup>9</sup> have been set for each tariff period until March 2019. These tariffs automatically reduce each tariff period. This is known as default degression.

3.9. The tariff period beginning on 1 January 2019 (or 1 October 2018 for micro CHP) and ending 31 March 2019 is the final tariff period for the FITs scheme. From 1 April 2019 there are no new tariff rates.

3.10. Figure 2 illustrates how the deployment caps mechanism will work in practice for all technologies with quarterly tariff periods. Please note, the dates at which caps are reached are examples to help understand the impact of caps on the Tariff and Eligibility Date.

**Figure 2: Deployment caps mechanism for technologies with quarterly tariff periods<sup>10</sup>**

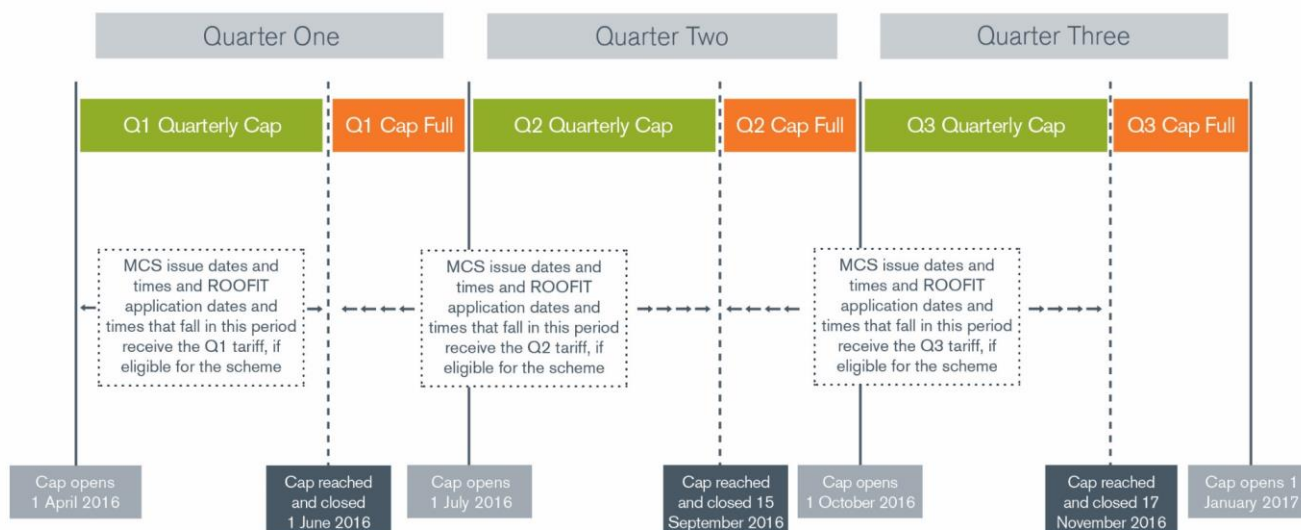

## What happens when a cap is reached

3.11. If an application for accreditation or preliminary accreditation causes the limit of the deployment cap for the final tariff period to be breached:

- We will not accredit that installation, and
- We will not accredit any other installations of that type whose applications are received after that installation.

<sup>9</sup> The FIT tariff tables are available in the Licence Conditions: <https://www.ofgem.gov.uk/licences-codes-and-standards/licences/licence-conditions>.

<sup>10</sup> The deployment caps mechanism will also work in practice for micro CHP, with the exception that each cap will cover 6-monthly tariff periods.

3.12. For tariff periods before the final tariff period: the installation that causes the deployment cap to be exceeded will not get allocated for that tariff period. This installation and all installations with MCS certificate issue dates or ROO-FIT application dates that fall after the cap has been reached will be placed on hold and cannot be added onto the CFR. Those installations will then be queued for entry into the next tariff period. Assuming there is sufficient capacity available within the next tariff period, the installation will be eligible to receive the tariff applicable to that tariff period or next if it is already full.

### *Example*

A cap opens on 1 April 2016 at 00:00:00 and will run until the end of that quarter (30 June 2016 at 23:59:59). An installation exceeds the cap for that tariff period and has an MCS issue date and time of 1 June 2016 at 12:20:35. Therefore the tariff rate for that tariff period is applicable to installations with a MCS issue date and time from 1 April 2016 at 00:00:00 to 1 June 2016 at 12:20:34.

All of those installations with an MCS issue date and time of after 12:20:35 are queued for entry into the next tariff period. The tariff rate for these installations will be the tariff rate associated with the tariff period that they fall into. MCS installations with MCS issue dates on or after 1 June 2016 at 12:20:34 will not be able to be added onto the CFR until the start of the next quarter.

## **Monitoring and reporting on deployment caps**

3.13. Appendix 10 provides information on how we monitor deployment caps and when we will report on deployment, including when a cap is reached.

## Tariff rate and eligibility date

### **MCS installations**

3.14. For MCS installations, allocation to a particular tariff period and tariff rate will be determined by the MCS certificate issue date and time.

3.15. For MCS community installations that pre-register before 1 April 2019 but receive their MCS certificate on or after this date, the tariff date is 1 January 2019.

3.16. The Eligibility Date of an installation is the date from which it is eligible to receive FIT payments. For installations with MCS certificate issue dates on or after 15 January 2016 the Eligibility Date will be the later of:

- The application date to the FIT licensee
- The start of the tariff period that the installation falls into.

### **Transitional MCS installations**

3.17. The pause to the scheme before deployment caps were introduced resulted in the creation of 'transitional installations'.

3.18. Installations that have MCS issue dates **and** commissioning dates before 15 January 2016 but which apply to their FIT licensee on or after this date will not count towards deployment caps. These installations must apply to their licensee before 1 April 2016 or they will not be able to receive FIT payments.

3.19. The Eligibility Date and Tariff Date of these transitional MCS installations will be 8 February 2016.

### **ROO-FIT installations**

#### **Preliminary accreditation**

3.20. Where an installation is granted preliminary accreditation the tariff rate for that installation will be based on the date the application is submitted to Ofgem and the corresponding tariff period the installation falls into.

3.21. For applicants that have been granted preliminary accreditation and are seeking full accreditation, if all eligibility criteria are met and all necessary actions are completed within the validity period<sup>11</sup> the Eligibility Date is the later of:

- The date an application is submitted to Ofgem converting preliminary accreditation to full accreditation
- The date the installation commissioned.

3.22. Where an application is submitted for FIT preliminary accreditation on or after 8 February 2016 and the cap has been reached, the validity period (ie the period within which the installation must have commissioned and an application submitted to Ofgem converting the preliminary accreditation to full accreditation) will begin on the later of:

- The application date
- The start date of the relevant tariff period.

---

<sup>11</sup> Preliminary accreditations expiring on or after 1 March 2020 receive a 12-month extension to their original validity period in which to convert to full accreditation.

### **Full ROO-FIT accreditation**

3.23. To apply for full accreditation, the installation must have commissioned on or before the date the application is submitted to Ofgem.

3.24. Where an installation is granted full accreditation (where an application for preliminary has not been submitted), the tariff rate for that installation will be based on the date of application to Ofgem and the corresponding tariff period that the installation falls into.

3.25. The Eligibility Date (ie the date from which FIT support become payable) will be the later of:

- The date that the application is submitted<sup>12</sup> via the Register, and
- The start date of the deployment period that the installation falls into.

3.26. The Eligibility Period (the period that the installation is eligible to receive payments for) will commence as of the Eligibility Date. The length of this period has not changed.

### **Transitional ROO-FIT installations**

3.27. Applications for full accreditation received before 15 January 2016 where the installation is commissioned after 15 January 2016 are not subject to deployment caps; they do not queue for entry into a cap and their capacity does not count towards the deployment caps. These installations will be eligible to receive FIT support from the date the installation was commissioned at the FIT tariffs available on the date the installation was commissioned.

3.28. Applications for full accreditation received before 15 January 2016 and commissioned before 8 February 2016 are not subject to deployment caps.

---

<sup>12</sup> An application is considered submitted once the application has been completed and submitted to Ofgem. The applicant must then go on and agree the declarations associated with the application.



## 4. Eligibility and Accreditation

### Chapter summary

Sets out the basic responsibilities of FIT licensees for determining eligibility and in the accreditation of installations under the FIT scheme.

### Closure of the scheme and eligibility

- 4.1. Applications received after 31 March 2019 shall not be accredited, except in the following instances:<sup>13</sup>
- 4.2. ROO-FIT scale (>50kW) installations that apply for pre-accreditation on or before 31 March 2019 benefit from standard validity periods to convert to full accreditation (subject to meeting all other eligibility criteria). They can also receive a grace period.
- 4.3. ROO-FIT scale installations with a preliminary accreditation which were initially due to expire on or after 1 March 2020 receive a 12 month extension to their original validity period.<sup>14</sup>
- 4.4. MCS scale ( $\leq 50$  kW) installations which commission and have an MCS certificate issued on or before 31 March 2019 have until 31 March 2020 to apply to their FIT licensee for accreditation.
- 4.5. MCS scale community installations that apply for pre-registration on or before 31 March 2019 get the standard 12-month validity period in which to commission and apply to their FIT licensee for accreditation.
- 4.6. MCS scale community pre-registrations which were initially due to expire between 1 March and 31 March 2020 receive a 12-month extension to their original validity period.<sup>12</sup>
- 4.7. MCS scale school installations that apply for pre-registration on or before 31 March 2019 get the standard 12-month validity period in which to apply to their FIT licensee for accreditation.

### Basic Eligibility Criteria

- 4.8. Eligible Low Carbon Energy Sources for the purpose of the FIT scheme are the following sources of energy or technology:

---

<sup>13</sup> For more information, please see ['Feed-in tariffs: Essential guide to closure of the scheme'](#)

<sup>14</sup> [The Feed-in Tariffs \(Amendment\) \(Coronavirus\) \(No2\) Order 2020](#). For more information, visit our [Changes to the FIT Scheme](#) web page.

- anaerobic digestion, as defined in the FIT Order,
- hydro generating station, as defined in the FIT Order,
- combined heat and power (CHP),
- solar PV, and
- wind.

4.9. The specified maximum capacity of Eligible Installations is set at 5MW of total installed capacity (2kW in the case of CHP). This means that it is possible to have up to 5MW of TIC generation from the same low-carbon energy source on a site.

4.10. Eligible CHP can join the FIT scheme on a pilot scheme basis; only the first 30,000 CHP installations added to the CFR will be eligible.

4.11. Only Eligible Installations within Great Britain can join the FIT scheme and must either be MCS-certified (or equivalent) or ROO-FIT accredited.

4.12. Electricity from installations which are selling or have sold electricity pursuant to a Non-Fossil Fuel Obligation (NFFO) or Scottish Renewable Obligation (SRO) arrangement will be ineligible to join the FIT scheme. However, these installations may still be eligible for the RO under certain circumstances. No micro-generators are subject to a NFFO or SRO agreement.

4.13. Installations which have received a grant in relation to the cost of purchasing or installing their installations from, or on behalf of, a public authority will not be eligible for the FIT scheme unless the grant is a permitted grant (see [Chapter four](#)). Where a grant for an installation is not a permitted grant, the grant must be repaid before the installation can be considered for the FIT scheme. The FIT generator should discuss grant repayment with the grant issuing body directly.

4.14. In order to be eligible for FIT Payments under the FIT scheme, installations must also have a compliant generation and/or export meter in place (see [Appendix 11](#)). If an installation exports all its electricity, it is not a requirement to have a separate generation meter but must have a compliant export meter.

4.15. When the scheme was open to new applications, an installation containing generating equipment which had previously been accredited under the FIT or RO scheme was not eligible to receive FIT accreditation. After accreditation you may replace generating equipment with

equipment that has formed part of an installation previously accredited under the FIT or Renewables Obligation schemes.<sup>15</sup>

4.16. The TIC for solar PV should be calculated by multiplying the rated output of the modules used by the number of modules.

### Off Grid Sites

4.17. Off grid sites are required to meet the same eligibility criteria as grid connected sites (discussed above). In addition, off grid generators will be required to sign the following declaration:

*"I hereby declare that it is my intention to use any and all electricity generated by my FIT installation and that I fully understand that any electricity generated but not so used will not be eligible for FIT payments."*

4.18. ROO-FIT generators will be required to sign such a declaration as part of the ROO-FIT accreditation process. Rather than asking micro-generators to sign a separate declaration, FIT licensees may wish to consider adding this declaration to the statement of FIT terms.

### Site

4.19. In advance of accreditation being granted, FIT licensees must undertake an assessment of the "Site" of an Eligible Installation. The extent of the Site will determine the extent of the Eligible Installation that is eligible for FITs payments. The extent of the Eligible Installation will in turn determine its TIC and its generation tariff.

4.20. The Site of an Eligible Installation is determined by reference to the following criteria:

- The meter point administration number ("MPAN") of the meter measuring the supply of electricity to the premises at which the installation is located;
- The address of the premises at which the installation is located;
- The Ordnance Survey grid reference at which the installation is located; and
- Any other factors which the Authority considers relevant.

4.21. Other factors that may also be taken into account are the planning situation and any electrical or mechanical interactions with other installations.

---

<sup>15</sup> For guidance on the term 'generating equipment' please see chapter six of the [FIT Guidance for Renewable Installations](#).

4.22. The site assessment must be completed as part of the application for FIT accreditation. The assessment must be completed on a case-by-case basis taking into account each of the factors detailed in paragraph 4.20.

4.23. In the main, where more than one installation of the same technology connects to the distribution or transmission network through the same grid connection (and hence share the same supply and/or export MPAN) they will be considered to be located on the same site.

### **Significance of MPAN in prescribed cases**

4.24. There are four scenarios where the supply MPAN will not be taken into account when completing the site assessment. This will enable certain installations sharing a grid connection to be considered to be located on separate Sites.

4.25. The following three scenarios are only applicable to installations with an Eligibility Date on or after 1 December 2012:

- Where two or more Eligible Installations of the same Eligible Low Carbon Energy Source are each attached to separate self-contained private residential dwellings, eg park homes.<sup>16</sup>
- Where two or more hydro installations are supplied with water by or from separate civil works.<sup>17</sup>
- Where two or more hydro installations are supplied with water by or from the same civil works and one or more of those installations are driven by a statutory compensation flow.<sup>18</sup>

4.26. The final scenario is applicable where no more than two installations with Eligibility Dates on or after 1 April 2015 share a supply MPAN. This scenario is:

- Where at least one of the installations is owned or is to be owned by a community organisation.<sup>19</sup>

---

<sup>16</sup> Article 15(4)(a) - FIT Order

<sup>17</sup> Article 15(4)(b) - FIT Order

<sup>18</sup> Article 15(4)(c) - FIT Order

<sup>19</sup> Article 15(4)(d) – FIT Order: See article 11(6) for the definition of a community organisation

### Claiming FIT Payments When Using a Site Exemption

4.27. Where several Sites share a grid connection, each Site should independently meter the renewable electricity generated. If separate generation metering is not available, generation payments may be calculated by pro-rating any available compliant meter readings<sup>20</sup>.

4.28. Where it is determined that several Sites share one connection into the distribution or transmission network, eligibility to receive FIT export payments may be affected:

- Where the individual TICs of Eligible Installations on a site is 30kW or less and no export meter is present, FIT export payments can be deemed.
- Where the individual TICs of Eligible Installations on a site is 30kW or less and an export meter is present, FIT export payments should be pro-rated on the basis of their respective TIC.
- Where the individual TICs of Eligible Installations on a site are greater than 30kW and an export meter is present, FIT export payments should be pro-rated on the basis of their respective TIC.
- Where the individual TICs of Eligible Installations on a site are greater than 30kW and no export meter is present, FIT export payments cannot be made.

### Example of Site Exemption

4.29. Figure 3 below sets out an example where there are five PV Eligible Installations that are all attached to separate buildings which are used as separate, self-contained private residential dwellings and all share the same connection to the grid (supply MPAN). All five installations have been determined as separate sites. They all have their own generation meters and as such could receive FIT generation payments. However, they all share the same export meter. Therefore, the exported electricity and hence export payments for the five Eligible Installations should be pro-rated on the basis of their respective TIC.

---

<sup>20</sup> SLCs Part C, Article 10.3

Figure 3: Example of site exemption

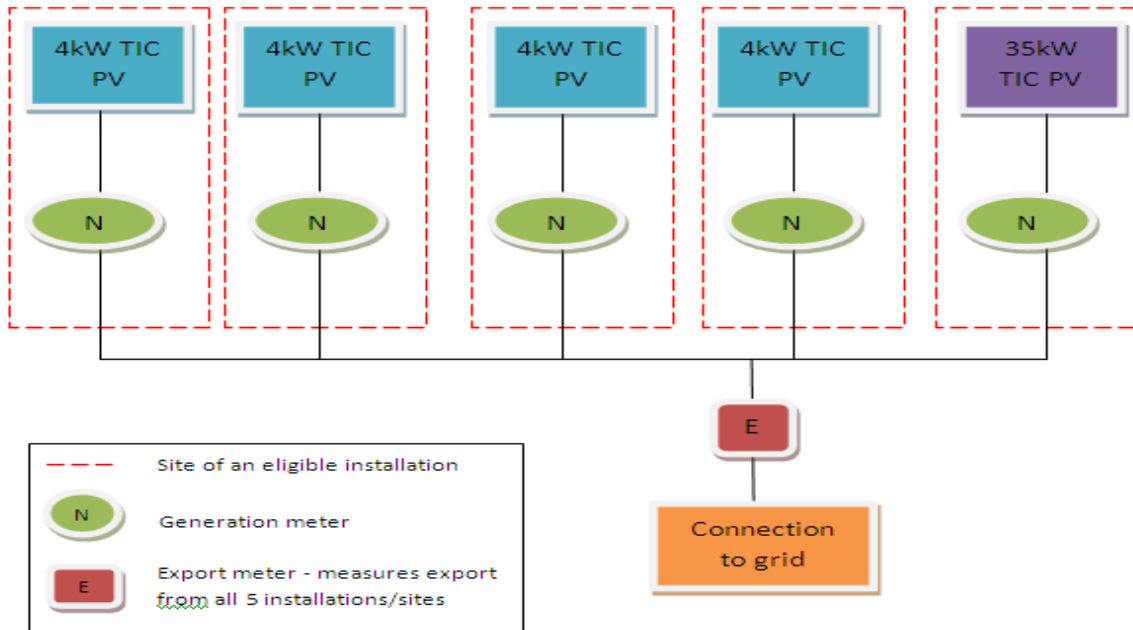

### Definitions for Solar PV Installations

4.30. The meanings to be given to “stand-alone” PV installations and PV Installations with a total installed capacity of 4kW or less are provided by definitions in the Standard Licence Conditions and their amendments (SLC). Those meanings are significant because they are used to allocate generation tariffs to installations. The following definitions apply for installations with a tariff date before 1 May 2013:

- **Stand-alone (autonomous):** Solar photovoltaic not attached to a building and not wired to provide electricity to an occupied building.
- **TIC of 4kW or less:** Solar photovoltaic with total installed capacity of 4kW or less, where attached to or wired to provide electricity to a new building before first occupation and Solar photovoltaic with total installed capacity of 4kW or less, where attached to or wired to provide electricity to a building which is already occupied.

4.31. Please note that the definitions described above changed for those installations with a tariff date on or after 1 May 2013 but before 1 July 2015 to:

- **Stand-alone (autonomous):** Stand-alone solar photovoltaic (not wired to provide electricity to a building).
- **TIC of 4kW or less:** Solar photovoltaic with total installed capacity not exceeding 4kW, wired to provide electricity to a new building and solar photovoltaic with total installed capacity not exceeding 4kW, wired to provide electricity to an existing building.

4.32. For installations with a Tariff Date on or after 1 July 2015, further altered definitions of 'stand-alone' will apply for a solar photovoltaic installation. Two cases in which installations are 'stand-alone' are identified:

- The first case is where an installation is not wired to provide electricity to a building.
- The second case is applicable only to the ROO-FIT accreditation process and arises where an installation with a Total Installed Capacity (TIC) greater than 250 kW is wired to provide electricity to a building (or buildings). Then, the maximum amount of electricity must be identified that can be either (a) carried via import connection(s); or (b) used by any Plant wired to, any building (or buildings) to which the installation is also wired to provide electricity. Where the amount of electricity identified in (a) or (b) is less than 10% of the installation's Declared Net Capacity, the installation is 'stand-alone solar photovoltaic'.

4.33. A solar PV installation with an Eligibility Date on or after 1 July 2015 will not be considered to be stand-alone if it is an extension to an existing FIT accredited installation which is not stand-alone solar photovoltaic.

4.34. On 8 February 2016 the PV tariff bands changed so that the <4kW tariff band became a ≤10kW tariff band, and the 4kW-50kW tariff band became a <10kW-50kW tariff band.

### Use of batteries and storage devices

4.35. It is possible that co-locating storage may impact the eligibility of an accredited FIT installation to receive continued support under the FIT scheme, or may alter the amount of support received. It is the responsibility of FIT Licensees to assess whether co-location of storage with a FIT Installation impacts on its eligibility or ability to receive FIT generation payments, and to keep track of this on the CFR.

4.36. Detailed scenarios are provided in our '[Guidance for generators: Co-location of electricity storage facilities with renewable generation supported under the Renewables Obligation or Feed-in Tariff schemes](#)'. Where FIT licensees are made aware of other scenarios where a battery or storage device is used and they are unsure as to whether the installation is eligible for payments, they should contact the [Renewables Compliance Team](#).

4.37. From 1 April 2018, all FIT Licensees should confirm whether an installation has co-located storage for new or amended applications. A question has been added to the CFR to allow licensees to directly amend installations and enter this information as part of the registration process.

4.38. In cases where there is co-located storage, a single line diagram (SLD) showing the FIT installation, the storage device and the metering must be provided by the FIT generator in

order to be able to determine that FIT payments are only being made for eligible electricity. The SLD should be uploaded to Documents section on the CFR.

4.39. ROOFIT scale installations that retrofit storage should notify Ofgem so we can review the metering arrangements. If a FIT licensee becomes aware that a storage device has been installed, the generator should be directed to us and the application flagged by email to [renewable@ofgem.gov.uk](mailto:renewable@ofgem.gov.uk). In cases where the generator has notified us and amended their application, they will receive an email from us confirming that it has been re-accredited, subject to the configuration being eligible.

4.40. If the configuration of the installation or metering arrangements are such that the installation is ineligible for payments, or an SLD is not available to confirm the metering arrangements, then payments should be suspended until this is rectified. A request to do this should be made through the CFR and the appropriate 'Under Investigation' form uploaded.

4.41. If there is any doubt as to the configuration of the metering arrangements, close attention should be paid to the anticipated meter readings and whether or not they fall within the expected tolerance limits. This could be seen as an indicator of whether or not a storage device is in use and a driver for the licensee to seek further information from the generator.

### Combining FIT and Grants

4.42. The FIT scheme was designed to replace publicly funded grants as a means of encouraging the growth of small-scale renewable generation. As such, it is generally not possible for an installation which has received a grant from public funds to be eligible for the FIT scheme.

4.43. The FIT Order prohibits the accreditation of an installation where a grant has been made from public funds towards any costs of purchasing and/or installing an installation.<sup>21</sup>

4.44. The term "grant from public funds" is defined in the FIT Order as:

*"A grant made by a public authority or by any person distributing funds on behalf of a public authority."<sup>22</sup>*

4.45. This includes, but is not limited to, funds distributed by:

---

<sup>21</sup> Article 7(3) of the FIT Order

<sup>22</sup> Article 2(1) of the FIT Order



- UK Government departments such as the Department for Environment Food and Rural Affairs (DEFRA), the Department for Energy Security and Net Zero or the Department of Business, Energy and Industrial Strategy.
- Local and Regional Councils,
- organisations distributing money on behalf of the Government and EU - such as Energy Savings Trust,
- European governments, and
- the National Lottery.

### Costs Associated with Purchasing or Installing an Installation

4.46. Costs associated with purchasing or installing an installation includes all costs associated with the Eligible Installation (see "Definitions of "Eligible Installation" and "Site" section), including all electrical components and the costs associated with installing a grid connection. This does not include grid reinforcement costs associated with the DNOs wider network. For 'hydro generating stations' this also includes the costs associated with the civil works.

### Costs Not Associated with Purchasing or Installing an Installation

4.47. Grants received for items outside of the Eligible Installation need not be declared as part of an application for FIT accreditation. Table 1 below provides some illustrative examples of costs that would not be considered as part of the Eligible Installation for the purposes of the FIT scheme.

**Table 1: Examples of costs not associated with an installation**

Technology	Example of costs that are not part of the installation for the purposes of FIT
PV	Pre-design feasibility studies. Local electricity grid reinforcement/upgrades.
Wind	Pre-design feasibility studies. Local electricity grid reinforcement/upgrades
Micro CHP	Pre-design feasibility studies. Local electricity grid reinforcement/upgrades
AD	Pre-design feasibility studies.

	<p>Infrastructure for transmitting electricity/heat generated by AD plant, for example, eg, to neighbouring buildings.</p> <p>Transforming digestate into different products, for example dewatering to create dry compost as opposed to a low dry matter liquid.</p> <p>Secondary gas treatment/use.</p> <p>Educational facilities associated with the AD plant, eg visitor centres.</p> <p>Local electricity grid reinforcement/upgrades.</p> <p>Large scale:</p> <p>Secondary feedstock pre-treatment.</p> <p>Small scale:</p> <p>Slurry/maize storage.</p>
Hydro	<p>Pre-design feasibility studies.</p> <p>Local electricity grid reinforcement/upgrades.</p>

**Declaring ‘a grant’ during the accreditation process**

4.48. During the accreditation process, all generators will be asked if they have received a grant or the offer of a grant from public funds for the purposes of purchasing and/or installing the installation. If a generator declares that a grant has been or will be received, licensees should assess whether the grant impacts the eligibility of the installation to receive FIT accreditation.

4.49. If the generator has received a grant and this has been repaid in full to the grant issuing body before they apply for accreditation, they must declare ‘yes’ when asked if they have received a grant or the offer of a grant from public funds. They should then be asked to provide documentary evidence of the grant being fully repaid as part of the application for accreditation.

**Assessing a Grant**

4.50. Where an applicant declares to have received a grant from public funds, licensees should undertake the following assessments:

- Whether the grant is a grant from ‘public funds’ (see Paragraph 4.44).
- Whether the grant was made for the purposes of purchasing and/or installing the installation.

4.51. As part of the grant assessment, FIT licensees should require a number of documents to be provided. This includes, but is not limited to:

- A copy of the grant application form submitted to the grant issuing body to request the grant funding.
- A copy of the full terms and conditions of the grant offer along with the grant offer letter.
- A full breakdown of what the grant was used for, including project costs and paid invoices.

4.52. Licensees should consider any additional supporting information provided by the FIT generator as part of the grant assessment.

### Grants Exemptions

4.53. There are a limited number of circumstances where an installation owner may be eligible to receive FIT payments despite having received a grant from public funds: generally, it will be a 'reasonable additional costs exemption'. If a licensee believes other exceptions may be applicable, they should contact us.

### Reasonable Additional Costs Exemption

4.54. The FIT Order 2012 allows an installation to receive FIT payments even if a grant has been received, provided that the grant is made in respect of the reasonable additional costs to avoid or mitigate environmental harm.

4.55. This may include, for example, measures to protect fish and other wildlife in small hydro schemes. The grant **must not** exceed the total reasonable additional costs.<sup>23</sup>

4.56. Costs associated with purchasing land or inefficient or poorly located installations will not be considered reasonable additional costs.

4.57. The costs and returns associated with solar PV, wind and CHP are relatively standard. Ofgem does not expect installations using these technologies to have reasonable costs associated with avoiding or mitigating environmental harm.

4.58. It is for the FIT generator to identify and provide supporting documentary evidence to the licensee that:

---

<sup>23</sup> When assessing whether the costs are reasonable additional costs, we will do so within the meaning of Article 7(3) and the definition of an eligible installation. The assessment is completed on a case-by-case basis.

- The installation has incurred reasonable costs, additional to the standard costs of purchasing or installing an installation of that technology and size.
- Those costs have been incurred in the avoidance or mitigation of environmental harm.
- Any grant received for the installation have been made to cover all or some of the cost of those measure and no other costs of the installation.

4.59. Ofgem cannot confirm whether a grant meets the reasonable additional costs exemption before receiving an application for accreditation. It is for the FIT generator to prove to the licensee that their installation meets the requirements of this exemption at the point of application.

### **Grants That Do Not Meet the Exemptions**

4.60. Where a grant for an installation does not meet any of the above exemptions, the grant must be repaid before the installation can be considered for FIT accreditation.

4.61. The FIT generator should discuss grant repayment with the grant issuing body directly. Where it is appropriate to do so, Ofgem will request evidence that a grant has been repaid to the relevant body before we consider an application for FIT accreditation.

### **False Declarations**

4.62. FIT generators must provide a declaration confirming that all information submitted in support of their application for accreditation is true and accurate.

4.63. Following accreditation, if the licensee becomes aware that the information provided in relation to the grant was inaccurate, Ofgem will consider withdrawing the accreditation using our powers under Article 17 of the FIT Order or instructing the FIT licensee to recoup FIT payments under Article 35 of the FIT Order.

### **Additional requirements for AD**

4.64. From 1 May 2017, AD generators that made a new application for preliminary accreditation or full accreditation on or after 1 May 2017 will have to comply with sustainability criteria. These generators will also be subject to feedstock restrictions and reporting requirements which may affect their FIT generation payments. FIT export payments will not be affected by these new requirements.

4.65. Generators who made an application for preliminary accreditation or full accreditation before 1 May 2017, but fall into a tariff period that starts on or after 1 May 2017, **will not** be required to comply with the sustainability criteria and feedstock restrictions.

4.66. FIT export payments will not be affected by these new requirements.

4.67. An AD generator will not be entitled to full FIT generation payments unless it complies with the sustainability criteria, feedstock restrictions and reporting requirements. In summary, these ongoing obligations are:

- Generators will have to submit quarterly sustainability declarations to confirm whether the feedstocks used in the previous quarter meet the sustainability criteria.
- Generators will have to submit annual feedstock declarations to confirm the feedstocks used in the previous year and whether the previous year's FIT generation payments are affected by the feedstock restrictions.
- Quarterly generation meter readings must be submitted to the FIT licensee within 28 calendar days from the end of the relevant quarterly period. Unless otherwise specified, the quarterly meter reading timetable will start from the installation's Eligibility Date. Please see Chapter 7 for further information.
- Installations with a TIC  $\geq 1$  MW will have to submit an annual independent audit report to Ofgem to demonstrate and verify compliance with the sustainability criteria and feedstock restrictions.
- Records of all feedstocks used for production of biogas by the installation must be kept. Ofgem may request these records throughout the duration of an installation's accreditation on the FIT scheme.

4.68. Failure to comply with these requirements may result in Ofgem instructing the FIT licensee to withhold/reduce/recoup FIT generation payments. Please see Chapter 7 for information on withholding, reducing and recouping FIT generation payments.

4.69. Please see Feed-in Tariffs: Guidance on sustainability criteria and feedstock restrictions for further information.

### Accreditation

4.70. To apply for the FIT scheme, installations must either be accredited via the ROO-FIT process or be MCS-certified.

### MCS Accreditation

4.71. MCS installations must commission and have an MCS issue date on or before 31 March 2019 in order to be eligible for accreditation, with the exception of pre-registered community installations. Applications can be made until 31 March 2020, as long as the installations commission on or before 31 March 2019. Pre-registered community and school applications

retain their standard 12-month validity periods. Pre-registered community applications which were initially due to expire between 1 March 2020 and 31 March 2020 receive a 12 month extension to their original validity period.<sup>12</sup>

4.72. MCS or equivalent certification is required for the following:

- PV with a declared net capacity of 50kW or less.
- Wind with a declared net capacity of 50kW or less.
- Micro CHP with an electrical capacity of 2kW or less.

4.73. This means that installations using these technologies must be commissioned by a MCS-certified installer using a MCS-certified product, or be certified under an equivalent scheme.

4.74. A valid MCS certificate issued to an installation is proof that that installation is MCS-certified and must be included with the application form at the time of submission to the FIT licensee. Chapter eight provides more detail on actions required if it is discovered that a MCS certificate is incorrect.

4.75. More information about the content of an MCS certificate can be found in the MCS User Guide for Installers, Market Operators and Reporting Users<sup>24</sup>. Each MCS certificate and MCS certificate number can be verified using the MCS Database<sup>25</sup>.

### **ROO-FIT Accreditation**

4.76. The following eligible low-carbon energy sources must apply through the ROO-FIT accreditation process:

- AD with a total installed capacity up to 5MW.
- Hydro with a total installed capacity up to 5MW.
- PV with a declared net capacity of greater than 50kW and up to a total installed capacity of 5MW.
- Wind with a declared net capacity of greater than 50kW and up to a total installed capacity of 5MW.

4.77. Installations must be commissioned before applying. Ofgem will determine eligibility and provide ROO-FIT accreditation. Successful applicants will be allocated a ROO-FIT accreditation number upon full accreditation. The format of the ROO-FIT full accreditation number will have

---

<sup>24</sup> <https://certificate.microgenerationcertification.org/public/Documents/Help.pdf>

<sup>25</sup> <https://certificate.microgenerationcertification.org/public/login.aspx>

a prefix of F, two letters for the technology, five numerical values and two letters for the country eg FPV12345EN.

### **Preliminary Accreditation**

4.78. Preliminary accreditation for FITs is a mechanism which allows certain prospective generators to obtain a tariff guarantee for a set validity period and confirmation of eligibility prior to commissioning the installation.

4.79. Preliminary accreditation was removed on 1 October 2015, and re-introduced on 8 February 2016. No applications for preliminary accreditation could be made in between these dates.

4.80. Preliminary accreditation is available to all installations that, once commissioned, would use the ROO-FIT route of accreditation (solar PV and wind installations with a DNC over 50kW and all AD and hydro installations). It is not available to extensions of accredited FIT installations.

4.81. The validity period of the preliminary accreditation tariff guarantee lasts for a fixed period of time beginning with the later of:

- the application date for preliminary accreditation, and
- the start date of the tariff period that the application for preliminary accreditation falls into.

4.82. The duration of validity is dependent on technology:<sup>26</sup>

- Solar PV – six months.
- AD and Wind – one year.
- Hydro – two years.

4.83. Community energy installations of any technology which apply for preliminary accreditation on or after 1 April 2015 will have a six-month extension to their validity period. The validity periods for community energy installations from 1 April 2015 onwards will be:

- PV – one year.
- AD and Wind – 18 months.

---

<sup>26</sup> Article 9(8) FIT Order

- Hydro – 30 months.

4.84. Preliminary accreditations which expire were initially due to expire on or after 1 March 2020 receive a 12-month extension to their original validity period.

4.85. For more information on the benefits available to community energy installations please refer to the Guidance for Community Energy and Schools found on our website.

4.86. FIT payments can only be made to a FIT generator, where installations granted preliminary accreditation have applied for and received full ROO-FIT accreditation.

4.87. Installations granted preliminary accreditation which successfully go on to receive full accreditation will have their tariff set at the rate applicable on the "Tariff Date".

4.88. Installations which have received ROO-FIT accreditation after converting from preliminary accreditation will have a preliminary accreditation number with a prefix of P, 5 numerical values, 2 letters for the technology and 2 letters for the country eg P12345ADEN) rather than an "F".

4.89. Full information on the ROO-FIT accreditation process and preliminary accreditation is available from the 'Feed-in Tariffs: Guidance for renewable installations' document available on the Ofgem website.<sup>27</sup>

### Community Energy Installations and School Installations

4.90. Additional benefits for community organisations and education providers were introduced on 1 December 2012.

4.91. These benefits focussed solely on non-domestic solar PV installations with an eligibility date on or after 1 December 2012. They allow community organisations who propose to commission or have commissioned community energy installations, not exceeding 50kW DNC to apply to Ofgem for pre-registration on or before 30 September 2015 in order to have their tariff "guaranteed".

4.92. They also allow for both community energy installations and school installations to obtain a relaxation from the existing minimum energy efficiency requirement, for non-domestic solar PV installations with an eligibility date on or after 1 December 2012 with a TIC not exceeding 250kW. Applications for this benefit can still be made.

4.93. Provisions do not apply to extensions to existing installations, even if the original installation meets the definition of a community energy or school installation.

---

<sup>27</sup> [www.ofgem.gov.uk/FITs](http://www.ofgem.gov.uk/FITs)



4.94. For example, where a solar PV installation meets the definition of either a community energy installation or a school installation, they will be required to present a non-domestic EPC of level G or above to benefit from the “higher tariff” (if not subject to the multi-installation tariff) instead of an EPC of level D or above.

4.95. There is no change for community energy and school installations with regard to the multi-installation tariff, which applies where the FIT generator or nominated recipient already owns or receives FIT payments from 25 or more other eligible solar PV installations. More information on the multi-installation tariff can be found later in this chapter.

4.96. From 1 April 2015 the legislation was amended to allow charities to be included under the definition of community organisation. Further benefits were also introduced for non-PV technologies.

4.97. On 1 October the tariff guarantee for MCS community energy installations was removed alongside the ability to apply for preliminary accreditation for ROO-FIT scale installations.

4.98. As of 8 February 2016 deployment caps were introduced. Please refer to paragraph 4.98 onwards and the ‘Feed-in Tariffs: Guidance for community energy and school installations’ for further information on the impact on Eligibility Date and Tariff Date.

4.99. When making an application to register for benefits in relation to community energy and school installations, regard should be had to the relevant articles of the FIT Order and our detailed guidance ‘Feed-in Tariffs: Guidance for community energy and school installations’<sup>28</sup>. As such, this section of the guidance should not be regarded as a comprehensive summary of the relevant provisions.

4.100. Queries regarding the new provisions for community energy and school installation or education providers should be emailed to [FITCommunity@ofgem.gov.uk](mailto:FITCommunity@ofgem.gov.uk).

### **MCS-FIT Community Energy/School Installations**

4.101. Ofgem will review and consider the supporting evidence to an application that an MCS-FIT solar-PV installation meets the definition of either a community energy or school installation, through a process known as pre-registration. This must take place **before** a FIT application is made to a FIT licensee. We will provide a pre-registration letter to the generators of installations that have met the relevant definition and therefore successfully pre-registered.

---

<sup>28</sup> [www.ofgem.gov.uk/FITs](http://www.ofgem.gov.uk/FITs)

4.102. The pre-registration of an MCS FIT community energy or school installation has a validity period of one year, beginning on the date we receive an application for pre-registration. School installations are only able to apply for pre-registration once they have commissioned.

4.103. A community energy or school installation that has successfully applied for pre-registration must commission (where it has not already) and apply for FIT accreditation with a FIT licensee **within** the validity period of the pre-registration if the tariff date for their installation is to be determined as described above.

4.104. Community pre-registrations which were initially due to expire between 1 March and 31 March 2020 receive a twelve month extension to their original validity period.

4.105. Where this occurs, the tariff rate that was valid on the Tariff Date will be assigned by the CFR to the installation, irrespective of the current tariff payable for that band.

4.106. If an application for FIT accreditation for a pre-registered community energy or school installation is received by a FIT licensee **outside** the validity period of its pre-registration, our duties in relation to the pre-registration of installations do not apply. The following consequences may follow from the expiry of the validity period:

- For community energy and school installations, the Tariff Date will be based on when an application for FIT accreditation is received by a FIT licensee. The relaxation of the energy efficiency requirement will not apply. This means the generator will need to submit an EPC of Level D or above to be awarded the higher tariff rate.
- For community installations where the MCS certificate is issued after 1 April 2019, the Tariff Date will be 1 January 2019.
- The tariff guarantee will also not apply to community energy installations.

4.107. FIT licensees will need to ensure that for all MCS-FIT community energy or school installations, standard documentation (ie MCS certificate, non-domestic EPC and the declarations relating to multi-installation tariffs and the energy efficiency requirement) are provided by applicants. Additionally, applicants must also provide to their FIT licensee a copy of the pre-registration or status verification letter, originally sent by Ofgem.

4.108. FIT licensees will be required to carry out all the same standard eligibility checks on community energy and school installations as they would with any other MCS-FIT installation. This includes checks on confirmation of ownership of the installation, generator and nominated recipient details and verification of supporting documentation (eg MCS and non-domestic EPC Certificates).

4.109. FIT licensees must ensure that the application and supporting documentation received is consistent with the information stated on the pre-registration or status verification letter. This will include the following:

- The application is from the community organisation or education provider named in the pre-registration letter
- The address of the building to which the installation is wired
- The technology of the installation is solar PV
- The total installed capacity and declared net capacity of the installation
- EPC Number (where applicable), and
- MCS Number (where applicable).

4.110. FIT licensees will be required to answer a number of questions when registering a **solar PV** MCS-FIT installation on the CFR, which will have been confirmed by Ofgem in the pre-registration letter. The information required to be entered on the CFR will be:

- whether the installation is a “community energy” or a “school installation”,
- the community/school reference number, and
- the Tariff Date for pre-registration applications received prior on or before 14 January 2016.

4.111. Further information on how to register an MCS-FIT installation on the CFR can be found in the FIT Central Register User Guide, available on the Ofgem website.<sup>29</sup>

### **Eligibility Dates and Tariff Dates for Community Energy Installations**

4.112. For community applications for pre-registration received by Ofgem before 1 October 2015 the Eligibility Date will be the later of:

- the date on which Ofgem received the application for pre-registration
- the date on which the installation was commissioned.

The Tariff Date for these installations will be the date the application is received by Ofgem.

---

<sup>29</sup> [www.ofgem.gov.uk/FITs](http://www.ofgem.gov.uk/FITs)

4.113. For community applications for pre-registration received by Ofgem on or after 1 October 2015 the Eligibility Date will be the later of:

- the date on which Ofgem received the application for pre-registration
- the date on which the installation commissioned.

The Tariff Date will be the same as the Eligibility Date.

4.114. For community applications for pre-registration received by Ofgem on or after 8 February 2016 but before 1 April 2019, where the installation has commissioned and its MCS certificate is issued before 1 April 2019, the Eligibility Date will be the later of:

- the date on which Ofgem received the application for pre-registration, and
- the start date of the tariff period that the installation falls into.

The Tariff Date will be the start date of the tariff period that the installation falls into.

4.115. For community applications for pre-registration received on or before 31 March 2019, where the installation's MCS certificate is issued on or after 1 April 2019:

- The Eligibility Date will be the date on which the application for FIT payments is received by a FIT licensee, and
- The Tariff Date will be 1 January 2019.

### **Eligibility Dates and Tariff Dates for School Installations**

4.116. For school applications for pre-registration received by Ofgem before 15 January 2016, the Eligibility Date will be the date the application is received by Ofgem. The Tariff Date will be the same as the Eligibility Date.

4.117. For school applications for pre-registration received on or after 15 January 2016 the Eligibility Date will be the later of:

- the date on which Ofgem received the application for pre-registration, and
- the start date of the tariff period that the installation falls into.

The Tariff Date will be the same as the Eligibility Date.

### **Ofgem Powers relating to accredited FIT Installations**

4.118. Under powers granted by the Feed-in Tariffs Order 2012, Ofgem may, in certain specified situations:

- Withdraw accreditation.
- Suspend accreditation.
- Change the tariff code.
- Attach conditions on the accreditation.
- Amend conditions of accreditation.

4.119. Those specified situations are:

- Where the decision to grant accreditation or preliminary accreditation was based on information which was incorrect in a material particular.
- Where any condition attached to an accreditation has not been complied with.
- Where an installation has been extended or modified in such a way that it would not be entitled to accreditation.
- Where Ofgem is notified by a relevant authority that the construction or operation of an installation is in breach of legislation, a licence or a consent (eg a planning authority notifies Ofgem that an installation has not been granted planning permission).

4.120. These powers are now reflected in additional status fields on the Central FIT Register (CFR). New installation and payment status codes have been added as well as a new capacity level status field and codes. FIT licensees will be able to view these codes and must consider them and any changes made to them before making FIT payments. Further information can be found on the Ofgem website.

4.121. Please refer to Chapter 6 for details on how the situations detailed above will be treated.

## 5. Additional requirements for solar PV

### Chapter summary

This chapter provides information about energy efficiency requirements for solar PV installations.

### Microgeneration Certification Scheme (MCS) applications and the Energy Efficiency Requirement

5.1. This chapter provides guidance about the Energy Efficiency Requirement (EER) for solar PV installations. It explains the role of Energy Performance Certificates (EPCs) in the context of the requirement, and also tells you how to assess whether the EER applies. It also explains how to assess whether the EER is satisfied, including what information must be provided by applicants and how to review it to allow you to make this assessment. The chapter also outlines situations where it might not be possible for a building to obtain an EPC.

5.2. The EER is relevant to every solar PV installation with a Total Installed Capacity (TIC) up to and including 250kW, including extensions (that commissioned before 15 January 2016), with an Eligibility Date on or after 1 April 2012, with the exception of stand-alone installations.

5.3. Feed-in Tariff (FIT) licensees are required to assess whether the EER applies, and if it does, whether the requirement is satisfied for solar PV installations with a Declared Net Capacity (DNC) up to and including 50kW, including eligible extensions. Licensees are also responsible for correctly assigning tariffs according to the outcome of their assessment of the EER.

### What is an EPC?

5.4. The Energy Performance of Buildings ("EPB") Regulations<sup>30</sup> require an Energy Performance Certificate (EPC) to be obtained whenever a building is constructed or marketed for sale or rent. The certificate gives an asset rating which indicates how energy efficient a building is.

5.5. A "rating band" between A (most energy efficient) - A+ in the case of non-domestic buildings - and G (least energy efficient) is allocated on both domestic and non-domestic EPCs as an indicator of the energy efficiency of the building.

5.6. A domestic EPC has two rating bands – an energy efficiency rating band and an environmental impact rating band. For the purpose of the EER under the FIT, the rating band

---

<sup>30</sup> Energy Performance of Buildings (England and Wales) Regulations 2012; Energy Performance of Buildings (Scotland) Regulations 2008 (as amended) - [www.legislation.gov.uk](http://www.legislation.gov.uk)

addressing energy efficiency is the relevant rating band. The EPC allocates an estimate of the amount of energy that would be required for certain activities (such as heating) associated with the use of the building.

5.7. A non-domestic EPC has one rating band – the Energy Performance Asset Rating band (Building Energy Performance Rating band in Scotland) which is based upon calculated greenhouse gas emissions. For the purpose of meeting the EER under the FIT scheme, this rating band is the relevant rating band.

5.8. The EPC is valid for ten years from the date of issue unless a new assessment is made and a new certificate is issued.

5.9. More information on EPCs can be found on the Ministry of Housing, Communities and Local Government (MHCLG) website<sup>31</sup> and the Scottish Government website.<sup>32</sup>

### **Assessing whether the Energy Efficiency Requirement applies**

5.10. The EER applies if a PV installation (or extension) with an Eligibility Date on or after 1 April 2012 is wired to provide electricity to one or more relevant buildings.

5.11. A “relevant building” is defined in the Standard Licence Conditions (SLCs)<sup>33</sup>, and must be a roofed construction which has walls, and for which energy is used to condition the indoor climate (eg using heating and cooling systems). A relevant building must also be a building in respect of which an EPC can be issued. A building needs to meet all aspects of this definition for it to be considered a relevant building. If any aspects of the definition are not met, then the building is not a relevant building.

5.12. Please see the “Multiple Buildings” section later in this chapter for further information about how this definition applies in situations where installations are wired to provide electricity to multiple buildings.

5.13. The assessment of whether or not a building meets the definition of a “relevant building” should be made at a single point in time. The relevant time for determining whether or not a building meets this definition, for the purposes of the EER, is shown in Table 3. The assessment

---

<sup>31</sup> MHCLG information on Energy Performance Certificates can be found at [www.gov.uk](http://www.gov.uk); “Energy Performance Certificates guidance” section

<sup>32</sup> Scottish Government Website - <http://www.scotland.gov.uk>

<sup>33</sup> Annex 5, paragraph 2.5 of SLCs; relevant links to the SLCs are provided on the Ofgem website (<https://www.ofgem.gov.uk/licences-codes-and-standards/licences/licence-conditions>) and also on the Department for Energy Security and Net Zero website: (<https://www.gov.uk/government/organisations/department-for-energy-security-and-net-zero>)

should not take into account whether the building will become or cease to become a relevant building at a future date.

FIT Application Date	Relevant time for assessing whether or not a building meets the definition of relevant building
On or after 10 May 2016	The FIT installation's commissioned date
Before 10 May 2016, but on or after 15 January 2016	The FIT installation's commissioned date
Before 15 January 2016	The FIT installation's eligibility date <sup>34</sup>

**Table 2: The relevant time for assessing whether or not a building meets the definition of a relevant building**

5.14. Installations wired to buildings that did not meet the definition of a relevant building at the relevant time, as set out in Table 3, are exempt from the EER and should be allocated the higher tariff. We refer to buildings that did not meet the definition of a relevant building at the relevant time as "non-relevant buildings".

5.15. However, installations wired to buildings that did meet the definition of relevant building at the relevant time, do need to satisfy the EER in order to receive the higher tariff, which should be assessed in line with Table 3.

5.16. Under the EPB Regulations some properties are exempt from the requirement for an EPC. However, if a building can be assessed and receive an EPC, and meets the definition of a relevant building, then the EER will apply under the FIT scheme, irrespective of whether an EPB exemption applies or not.

### **Reviewing applications where the FIT Generator declares they are exempt from the Energy Efficiency Requirement**

---

<sup>34</sup> For these installations, the eligibility date is the later of the commissioned date or the application date. For extensions, where the commissioning date is before 15 January 2016, the eligibility date is the commissioned date. See Chapter 7 for more information.



5.17. If the FIT Generator declares that their installation is exempt from the EER, they must show that all buildings to which the PV installation is wired to provide electricity did not meet the definition of a relevant building at the relevant time (as specified in Table 2).

5.18. Where an EPC could not be issued for the building (or the building did not meet any other part of the definition of a relevant building) at the relevant time, they should complete the template declarations in Appendix One and provide these to the FIT Licensee.

5.19. If the FIT Generator has not provided these as part of their original application, then the Licensee should direct them towards the declarations during the application process. One of the declarations should be completed by an energy assessor and the other by the FIT Generator. They should clearly explain why the building to which the installation is wired did not meet the definition of a relevant building at the relevant time for assessment.

5.20. When reviewing the declarations, the FIT licensee should ensure the declarations provided by the EPC assessor and FIT Generator give them assurance that the installation did not meet the definition of a relevant building, and is therefore exempt from the need to satisfy the EER. The FIT licensee should also verify the credentials of the EPC assessor making the declaration, by searching for the name and accreditation details of the EPC assessor on the Landmark Register.<sup>35</sup>

5.21. The higher tariff should only be allocated to an installation where the declaration and/or additional evidence demonstrates that the installation was exempt from the EER at the relevant time for assessment.

5.22. If the applicant is unable to demonstrate that the installation is exempt from the EER, and also cannot meet the requirement as set out in Table 3, then the installation should be allocated the lower tariff.

5.23. The FIT licensee should seek additional evidence from the generator and/or EPC assessor if they are not satisfied that the evidence provided by the FIT Generator demonstrates that the installation is exempt from the EER eg if the declarations are unclear or provide limited information about why the installation was not wired to a relevant building at the relevant time for assessment (as specified in Table 2).

---

<sup>35</sup> EPC assessors operating in England and Wales can be found using the search function on the [EPB register website](#). EPC assessors operating in Scotland can be found using the search function on the [Energy Saving Trust's website](#).

5.24. As part of their assessment, the FIT Licensee should consider whether the dates of the FIT Generator’s and EPC assessor’s declarations are appropriate in relation to the relevant time for assessing the EER (as specified in Table 2).

5.25. For example, for applications made on or after 15 January 2016, if the declarations are dated before the installation commissioned, then the building may have become a relevant building between the declaration and the commissioned date. These declarations would be of little value in assessing whether the installation is exempt from needing to satisfy the EER. In these cases, the FIT Licensee can request that the declarations in Appendix One are provided again and that the time of the assessment is made in relation to the installation’s commissioned date.

5.26. For applications made on or after 15 January 2016, declarations made after the commissioned date are acceptable. The declaration must make it clear that the EPC assessor and FIT Generator are assessing whether or not the installation was wired to a relevant building on the installation’s commissioned date. This date should be clearly indicated on the declaration but may be different to the date that the declaration is signed or provided.

**Assessing whether the Energy Efficiency Requirement is satisfied**

5.27. If an eligible installation is wired to a building(s) that did meet the definition of relevant building at the relevant time, then the EER applies and the FIT licensee must assess whether the requirement is satisfied in order to assign the correct tariff.

5.28. The EER is set out in Table 3:

**Table 3: the Energy Efficiency Requirement**

FIT Application Date	Energy Efficiency Requirement
On or after 10 May 2016	a) an appropriate EPC of level D or above must have been issued <b>before</b> (but not more than 10 years before) the commissioning date of the FIT installation, and  b) the EPC was, on the date on which the installation was commissioned, the most recently issued energy performance certificate for that building.
Before 10 May 2016, but on or	a) an appropriate EPC level of D or above must have been issued <b>on or before</b> (but not more than 10 years before) the commissioning date, and

after 15 January 2016	b) the EPC was, on the date on which the installation was commissioned, the most recently issued energy performance certificate for that building.
Before 15 January 2016	a) an appropriate EPC level D or above must have been issued <b>on or before</b> (but not more than 10 years before) the Eligibility Date of the FIT installation, and  b) the EPC was, on the Eligibility Date of the installation, the most recently issued energy performance certificate for that building.

5.29. Where the EER applies to an installation, the above requirements need to be satisfied for the higher tariff to be assigned to the installation (provided that the multi-installation tariff does not apply). Where the EER applies to the installation and is not satisfied, the lower tariff is to be assigned to the installation.

5.30. Further information on EPCs and how to review them when the EER applies is set out later in this chapter.

5.31. An explanation of the effect of the EER and multi-installation tariff in terms of the higher, middle and lower tariff rate is provided in the multi-installation tariff section.

5.32. The tariff applying to an installation cannot change from either the lower rate to the middle or the higher rate; or from the middle rate to the higher rate.

5.33. There are relaxed requirements for schools and community organisations. Please refer to the sub-section titled "Community energy and school installations" in Chapter 4 for details on how the EER applies to these installations.

5.34. Please note that a Display Energy Certificate (DEC) will not be accepted as proof of meeting the EER.

### Reviewing applications and EPCs when the Energy Efficiency Requirement applies

5.35. Where the EER applies, the EPC (original or copy) should be submitted during the application process. A draft EPC will not be accepted as proof of meeting the EER.

5.36. Where this evidence has not been received by the FIT licensee to verify that an EPC of level D or above has been achieved by the relevant dates set out in Table 3, the lower tariff will apply to the FIT installation.

5.37. In cases where the evidence provided to the FIT licensee does not correlate with the information on the EPB Register, the accredited body responsible for the EPC should be notified. Details of the relevant accreditation body are provided on the EPC.

5.38. This guidance will be updated, as appropriate, to reflect any changes to accessing the EPB Registers in England and Wales, and in Scotland.

### **England and Wales: Checking EPC information for domestic dwellings and non-domestic buildings**

5.39. The EPC is lodged on the Landmark Register and can be accessed here for domestic dwellings:

<https://www.epcregister.com>

5.40. For non-domestic buildings the EPC can be accessed here:

<https://www.ndepcregister.com>

5.41. EPC information can be accessed from the EPB Registers by using either the relevant Report Reference Number (RRN) or the address of the property. If the building owner or tenant has opted out the EPC from public disclosure, then the EPC can only be retrieved using a valid RRN.

5.42. FIT licensees should check the following criteria against the EPC provided by the FIT generator:

- the unique RRN of the EPC,
- the address and postcode of the building assessed,
- the date the certificate was issued (and that this meets the EER as specified in Table 3), and
- the “asset rating” to confirm that the building has been rated level D or above.

### **Scotland Checking EPC information for domestic dwellings (not new build)**

5.43. The EPC information for certificates issued in Scotland is lodged on the Energy Savings Trust Scotland’s Homes Energy Efficiency Database Register and can be accessed at:

<https://www.scottishepcregister.org.uk/>

5.44. This register contains information on all EPCs issued in Scotland for domestic dwellings. EPC information can be accessed from the Scotland EPC Register by someone who has the relevant RRN.

5.45. FIT licensees should check the following criteria against the domestic EPC provided by the FIT generator:

- the unique RRN of the EPC,
- the address of the building assessed,
- the date the certificate was issued (and that this meets the EER as specified in Table 3), and
- the 'asset rating' to confirm that the building has been rated level D or above.

### **Scotland Checking EPC information for non-domestic buildings**

5.46. The EPC information for certificates issued in Scotland is lodged on the Energy Savings Trust Scotland's Homes Energy Efficiency Database Register and can be accessed at:

<https://www.scottishepcregister.org.uk/>

5.47. This register shows all non-domestic EPCs lodged from 28 January 2013 and the EPCs will include a unique RRN. However, it will not show non-domestic EPCs with an issue date of 27 January 2013 or earlier and these EPCs will not include a unique RRN. EPC information can be accessed from the Scottish EPC Register by someone who has the relevant RRN.

5.48. FIT licensees should check the following criteria against the non-domestic EPC (with an issue date on or after 28 January 2013) provided by the FIT generator:

- the unique RRN of the EPC,
- the address of the building assessed,
- the date the certificate was issued (and that this meets the EER as specified in Table 3), and
- the 'asset rating' to confirm that the building has been rated level D or above.

5.49. For non-domestic EPCs (with an issue date before 28 January 2013) provided by the FIT generator, FIT licensees should ensure the original or photocopy of the EPC is signed by the FIT generator are submitted as part of the application. The EPC will not have an RRN so the FIT licensee will not be able to check the EPC against the register, however they must check that the EPC:

- is a Scottish EPC,
- is a non-domestic EPC,

- contains an address,
- contains a certificate date (and that this meets the criteria of the EER as specified in Table 3), and
- has an 'asset rating' to confirm that the building has been rated level D or above.

5.50. The 'asset rating' of a non-domestic property in Scotland differs in terms of methodology to those produced for properties in England and Wales. To take account of this Scottish non-domestic EPCs may at some point include an indicative or equivalent 'asset rating' as if the property was assessed under the regime in place in England and Wales. If this is the case, then the indicative rating should be used as the determinant of whether an installation has met the EER.

### **Scotland Checking EPC information for new build**

5.51. For installations with these EPCs FIT licensees should ensure the original or photocopy of the EPC is signed by the FIT generator are submitted as part of the application. The FIT licensee will not be able to check the EPC against the register, however they must check that the EPC:

- is a Scottish EPC,
- is a new build EPC,
- contains an address,
- contains a certificate date (and that this meets the EER as specified in Table 3), and
- has an 'asset rating' to confirm that the building has been rated level D or above.

5.52. The Scottish Government now requires new build EPCs to be lodged on completion of new buildings but this only applies to those where the building warrant is applied for on or after 9 January 2013, so these will only start appearing on the register during the latter part of 2013. These EPCs will include a RRN.

5.53. If a new build EPC is identified which includes an RRN, FIT licensees should check the following criteria against the new build EPC provided by the FIT generator using the Scotland EPC Register ([www.scotlandepcregister.org.uk](http://www.scotlandepcregister.org.uk)):

- the unique RRN of the EPC,
- the address of the building assessed,

- the date the certificate was issued (and that this meets the criteria of the EER as specified in Table 3), and
- the 'asset rating' to confirm that the building has been rated level D or above.

### **Other cases where it might not be possible to obtain an EPC**

5.54. In some cases, it may not be possible to obtain an EPC for a building to which a solar PV installation is wired to provide electricity and which is used for non-domestic purposes, for reasons associated with the Simplified Building Energy Model (SBEM) assessment methodology. Common scenarios that arise in such cases are set out in 5.54 and 5.55.

5.55. There are instances of no standardised or modelled use of some buildings included within the 'data libraries' used by the assessment tool, SBEM. This includes those where standardised uses were omitted from the development of SBEM. In such cases SBEM cannot generate a numerical indicator of the amount of energy required to meet different needs associated with standardised uses of such buildings.

5.56. There are also instances where a building does not have any heating and it is inappropriate to assume that electric heating facilities are available. In such cases no assumptions are made in relation to heating in order to carry out SBEM assessments and it may therefore be inappropriate to carry out such an assessment. In such cases however, if there is any zone of the building that is occupied by any persons (for example an office or staff room in a warehouse), then an assessment of the heating requirements of that zone of the building may be made and an EPC may be generated.

### **Extensions**

5.57. Extensions with an Eligibility Date on or after 1 April 2012 must also be assessed against and (if applicable) meet the EER.

5.58. The Eligibility Date for extensions will be based on its commissioning date *only*, as the application date is that of the original installation. However, extensions with a commissioning date on or after 15 January 2016 are no longer eligible for FIT payments.

5.59. The paragraphs of this section on should be read in conjunction with sections 6.75 to 6.99 of this guidance document covering extension rules and additional capacity. These sections set out further extension rules which must be considered when assessing eligibility of an extension.

### **Multiple buildings**

5.60. Where an installation is wired to provide electricity to a number of buildings that are relevant buildings only one of those buildings needs to satisfy the EER.

5.61. The following examples describe different scenarios and explain what evidence is needed, where an installation is wired to provide electricity to:

- One relevant building: must provide an EPC for that building.
- One non-relevant building (ie a building that does not meet the definition of a relevant building): must prove that the building is not a relevant building (eg declaration from EPC assessor and FIT Generator) and that they therefore do not need to meet the EER.
- Multiple relevant buildings: must provide one EPC for any one of the buildings.
- Multiple non-relevant buildings: must prove that all the buildings are exempt and do not need to satisfy the EER.

A combination of relevant and non-relevant buildings: must provide one EPC for any of the relevant buildings.

### ROO-FIT Community Energy/School Installations

5.62. Ofgem will review the supporting evidence in ROO-FIT applications to verify whether the installation meets the definition of either a "community energy installation or school installation", as part of a ROO-FIT application **instead** of the pre-registration process. This will include the submission of declarations relating to multi-installation tariffs and the EER. ROO-FIT installations will receive a confirmation letter where the definition of either a community energy or school installation has been met.

5.63. There is no specified time limit for ROO-FIT scale community energy or school installations as they are not subject to the pre-registration process. Therefore, there are no time restrictions between the granting of ROO-FIT accreditation and an application for FIT payments being received by a FIT licensee.

5.64. Further information on how to register a ROO-FIT installation on the CFR can be found in the FIT Central Register User Guide.

### Multi-installation tariffs (PV only)

5.65. Multi-installation tariffs apply to any solar PV installation with a TIC up to and including 250kW and with an Eligibility Date on or after 1 April 2012 where the FIT generator or nominated recipient already owns or receives FIT payments from **25 or more other** eligible solar PV installations.

5.66. For the purposes of this document, the multi-installation tariff is a reduced, middle tariff rate that applies to an installation. However, where the EER is applicable and not met, the lower tariff rate will always apply.



5.67. Tariff information is available from Ofgem's website. Please see below for an explanation on the effect of the EER and multi-installation tariff in terms of the higher, middle and lower tariff rate.

5.68. An assessment of whether the multi-installation tariff applies must be made during the application process for the accreditation of an Eligible Installation regardless of whether the EER has been met or not.

### **Determining whether multi-installation tariffs apply**

5.69. FIT licensees must assess installations and determine if the multi-installation tariff applies, for which the following criteria are relevant:

- where the FIT generator for the installation and any persons who are “connected persons” in relation to them are, or have applied to be, the FIT generator or nominated recipient for 25 or more other eligible solar PV installations on different sites, the multi-installation tariffs will apply, or
- where the nominated recipient for the installation and any persons who are “connected persons” in relation to them are, or have applied to be, the FIT generator or nominated recipient for 25 or more other eligible solar PV installations on different sites, the multi-installation tariffs will apply.

5.70. A “connected person” in relation to a FIT generator or a nominated recipient, means any person connected to that person within the meaning of the Corporation Tax Act 2010.

5.71. Where participants or prospective participants in the FIT scheme are assessing whether the multi-installation tariffs may apply to them it is suggested that they take independent legal advice relevant to their circumstances. Participants or prospective participants should note that the FIT legislation requires that a FIT generator or nominated recipient and (in each case) “connected persons” are assessed collectively when assessment is made of whether the multi-installation rate is applicable.

5.72. Below are some common **illustrative examples only** of how a person (“person A”) may be a “connected person” in relation to another person (“person B”):

- person A is person B’s spouse or civil partner.
- person A is person B’s relative.
- person A is a relative of person B’s spouse or civil partner,
- person A is a spouse or civil partner of a relative of person B,

- person A and person B are both companies and the same person ("person C") has control over both, or
- person A and person B are both companies; person C has control over person A; and persons connected with person C have control over person B.

### **Determining Multi-Installation Tariff Application on Change of FIT generator or Nominated Recipient**

5.73. When a FIT licensee receives a valid request for a change to the FIT generator or nominated recipient of an installation; if the new FIT generator or nominated recipient is identified as be a FIT generator or nominated recipient for 25 or more other eligible solar PV installations on different sites then the multi-installation tariff rate will apply to those installations included in the request.

5.74. This only applies to PV installations with an Eligibility Date on or after 1 April 2012 (ie only those installations where the multi-installation questions were asked at the time of application).

### **Continued Application of the Multi-Installation Tariff**

5.75. If before a change in FIT generator or nominated recipient an installation is receiving the higher rate and following the change the multi-installation tariff is to apply, the tariff level will be lowered to the middle rate as appropriate.

5.76. If before a change in FIT generator or nominated recipient an installation is receiving the middle rate then, following the change, although the criteria for the multi-installation tariff may no longer apply, the middle tariff will continue to apply.

### **Declarations**

5.77. Applications for accreditation and notices of changes of FIT generators or nominated recipients for installations with an Eligibility Date on or after 1 April 2012 must include a declaration relating to the multi-installation tariffs (see Appendix One).

5.78. The FIT generator, and where applicable the nominated recipient, will be required to sign a declaration to confirm that they are or are not the owner or nominated recipient for 25 or more other solar PV installations.

5.79. There are a number of declarations that can be signed within the Appendices, for which there are various outcomes, as set out below:

- Where **Declaration 1** (Appendix One) for installations has been signed, this indicates that the multi-installation tariff will be applicable to the installation.

- Where **Declaration 2** (Appendix One) for installations has been signed, this indicates that the multi-installation tariff will not be applicable to the installation.
- Where **Declaration 1** (Appendix Two) for changes to the FIT generator or nominated recipient has been signed, this indicates that the multi-installation tariff will be applicable to the installation.
- Where **Declaration 2** (Appendix Two) for changes to the FIT generator or nominated recipient has been signed, this indicates that the multi-installation tariff will not be applicable to the installation, unless already subject to the middle tariff.

5.80. **We advise all parties to read the relevant sections of the FIT Order and SLCs and take their own legal advice, before signing the relevant declarations.**

### **Existing installations, extensions and other technologies**

5.81. Existing solar PV installations with an Eligibility Date before 1 April 2012 count towards the assessment of whether the multi-installation tariff applies to installations with an Eligibility Date on or after 1 April 2012. However, the Tariffs for these existing installations will not change as a consequence of the multi-installation tariff applying to any new installations.

5.82. In these circumstances the multi-installation tariff will apply to the 26<sup>th</sup> installation and each subsequent installation with an Eligibility Date on or after 1 April 2012, depending on whether the EER applies and has been met.

5.83. Extensions to accredited solar PV installations will not be treated as separate installations when assessing whether the multi-installation tariff applies.

5.84. FIT installations using technologies other than solar PV will not be included when assessing whether the multi-installation tariff applies.

### **Effect of Energy Efficiency and Multi-Installation on Tariff Rates**

5.85. From 1 April 2012, there are 3 possible tariff rates available to solar PV installations with a TIC up to and including 250kW, including extensions, with the exception of stand-alone with an Eligibility Date on or after 1 April 2012: a higher rate, a middle rate and a lower rate. These rates will be dependent on meeting the EER and whether the multi-installation tariff applies.

5.86. Tariff information is available from Ofgem's website<sup>36</sup>.

---

<sup>36</sup> [www.ofgem.gov.uk/FITs](http://www.ofgem.gov.uk/FITs)

5.87. Table 4 below provides the tariff outcomes based on a new solar PV installation up to and including 250kW, including extensions, with the exception of stand-alone, from 1 April 2012 and its interaction with the EER and whether the multi-installation tariff applies.

**Table 4: Effect of energy efficiency and multi-installation on tariff rates**

<b>New solar PV installations with an Eligibility Date on or after 1 April 2012 (TIC up to and including 250kW, including extensions, with the exception of stand-alone)</b>	<b>Multi-installation tariff applies</b>	<b>Multi-installation tariff does NOT apply</b>
<b>Energy efficiency requirement applicable and met</b>	Middle rate	Higher rate
<b>Energy efficiency requirement applicable and NOT met</b>	Lower rate*	Lower rate*
<b>Energy efficiency requirement not applicable</b>	Middle rate	Higher rate

\* Installations will receive the lower tariff rate when an installation to which the EER applies, has not met the EER, regardless of whether multi-installation tariff applies.

## 6. Registration of Eligible Installations

### Chapter summary

This chapter provides guidance on the steps required when registering FIT generators.

6.1. FIT licensees are responsible for determining whether MCS-certified installations are suitable for participation in the FIT scheme. Ofgem accredits ROO-FIT installations.

6.2. Licensees are obliged to retain documents relating to the FIT Scheme for a period of 5 years, and it is expected that data relating to all FIT scheme participants accredited will be retained until the end of their eligibility period, and for a standard retention period beyond that. It is for FIT licensees as the Data Controllers to determine the length of this standard retention period in line with the guidance provided by the Information Commissioner's Office. This data should be made accessible for auditing by Ofgem and any organisation appointed by Ofgem. Electronic records are permitted for the purpose of complying with this requirement.

### Verification of accreditation details

6.3. FIT licensees are required to verify that the certification or accreditation details given by an applicant (normally a MCS certificate number or Ofgem ROO-FIT accreditation number) are valid and relate to that installation. The FIT licensee should cross reference the details given by the FIT applicant with the MCS Database and CFR.

### MCS certificate check under deployment caps

6.4. Any installation with an application date of on or after 15 January 2016 will be required to provide the MCS certificate issue date and time. This date and time is used to calculate the tariff period that an installation falls into (with the exception of community installations where the MCS certificate is issued after 1 April 2019, which fall into the tariff period beginning 1 January 2019).

6.5. To record the MCS certificate issue date on the CFR licensees should take the issue date from the first version issued. If a generator provides a later version of this certificate, then licensees should use the MCS issue date of the first version but the details held on the later version. This is to prevent generators from being unfairly impacted by errors made on certificates by installers. In this instance it is not necessary to request a copy of the original certificate as proof of the original issue date. This information can be gained from the MCS database using the 'Certificate Audit' report.<sup>37</sup>

---

<sup>37</sup> <https://certificate.microgenerationcertification.org/>

6.6. An MCS installation must be commissioned before an MCS certificate can be issued. If a certificate is amended so that the commissioning date is now after the original MCS certificate issue date, licensees should use the issue date of the first version issued after the installation commissioned. The MCS certificate must be issued on or before 31 March 2019 to meet the scheme eligibility requirements. Please refer to Chapter 4 for further information on eligibility and accreditation.

6.7. It will not be possible to add MCS installations onto the CFR where the MCS certificate issue date is within 14 days of the current date. This is to allow Ofgem time to update the CFR to reflect a cap being reached.

6.8. Paragraphs 6.4 to 6.7 of this section should be read in conjunction with paragraphs 8.24 to 8.29 of this guidance document which set out specific rules in relation to changes to MCS certificates.

### **Existence of other installations on the same site check**

6.9. Before adding the FIT applicant's details on the CFR, FIT licensees should search the CFR to ascertain whether any accredited FIT installations exist on the same site. If the search confirms that other accredited FIT installations are present, FIT licensees should review this information and contact the CFR Team ([fitregister@ofgem.gov.uk](mailto:fitregister@ofgem.gov.uk)) for more information. They should also take note of the status of the other accredited FIT installations that are present.

6.10. If the entire capacity of the accredited FIT installation has been decommissioned (installation status 'removed') then any new installation on that site must be added as a new registration. However, if the accredited FIT installation already present has any installation status other than 'removed' then the new capacity, if it is the same technology type, will be treated as an extension. Extensions with a commissioning date on or after 15 January 2016 are not eligible for FIT payments.

6.11. If the installation the FIT licensee is trying to add shares the same meter with an existing installation, the FIT licensee should advise the FIT applicant that they need to contact the other FIT licensee for FITs. Installations sharing the same generation and/or export meter should be assigned to the same FIT licensee. If no meter sharing arrangements occur, FIT licensees may proceed with the application.

### **Identity checks**

6.12. When registering an Eligible Installation, a FIT licensee is required to ensure that the identity of the FIT generator is verified.

6.13. A full credit check is a suitable mechanism for checking a FIT generator's identity. If by virtue of an existing relationship with the FIT applicant, the FIT licensee has already carried out such a check, the FIT licensee will not be required to request further proof of identity.

6.14. For all other FIT applicants, FIT licensees are required to undertake an identification check to ensure that the person or company stated as the owner of the Eligible Installation is genuine. Examples of identification are a photocopy of:

- passport,
- driving licence, or
- equivalent identification document issued by a recognised official body.

6.15. A FIT licensee must request domestic installation owners to provide proof of address. This may take the form of utility bills, bank statements, council tax bills or equivalent documents, unless these records are already held by the FIT licensee by virtue of an existing business relationship. Alternatively, a FIT licensee may rely on a credit agency reference check to confirm proof of address.

6.16. Non-domestic installation owners must prove their identity by providing details of their company registration and proof of address to the FIT licensee.

### **Ownership checks**

6.17. FIT licensees are also responsible for establishing that a FIT applicant is the owner of the Eligible Installation. FIT licensees are required to obtain documented evidence that shows the relationship between the owner and the Eligible Installation such as:

- A receipt or other documentation stating ownership, or the transfer of ownership from the previously stated owner (invoices may be accepted if the values are redacted).
- A copy of the sale and purchase agreement transferring ownership from one party to another as part of a property sale, or equivalent documentation showing the installation has been paid for in full.

6.18. The owner of the generating equipment may be different from the owner, leaseholder or tenant of the property or site at which the generating equipment is located. Where an installation is owned by a company or third party via a private financial scheme/programme, FIT licensees should check and obtain copies of a signed 'agreement' between the relevant parties, such as lease agreements.

6.19. In situations where companies or third parties have been unable to accurately describe their installations during the application process, FIT licensees should:

- Request additional evidence, where appropriate, that the owner of the property is aware of the 'agreement' and the generator has made them aware of the obligations under the scheme for the site to be accessed.
- Request first hand confirmation from the property owner that they are aware of the registration of the installation for the scheme and the details of the site.
- Reject any application where the FIT licensee is not comfortable that the information being provided is accurate.

6.20. When ownership changes during the eligibility period of a FIT Installation, the previous owner must inform the FIT licensee as soon as reasonably possible of the change. The new owner will also need to provide evidence of the change in ownership to the FIT licensee, so this can be recorded and assessed.

### **Ownership disputes**

6.21. Where ownership of an existing FIT Accredited Installation is disputed, the party disputing the ownership will need to provide evidence to support this claim to the FIT licensee. On receiving evidence, the FIT licensee will need to assess its validity against that provided during the application process. It can then be escalated to a formal ownership dispute, if necessary.

### **Requests for ownership information**

6.22. When dealing with requests for ownership information from FIT generators (eg where they have bought a house with PV fitted, but are unsure as to whether or not they are the owner), we can only provide details of an installation when the person requesting it has a legitimate claim over the ownership of the installation. In situations where there is no legitimate claim, we cannot provide ownership information.

### **Death of a FIT generator**

6.23. In the case of the notification of the death of a prospective FIT generator during the accreditation process, the personal representative of the deceased, acting under a grant of representation,<sup>38</sup> can continue the application.

6.24. For FIT installations which are accredited before the FIT generator's death, evidence for the sale or gift of the installation by the deceased FIT generator's personal representative is

---

<sup>38</sup> A grant of representation is a court order, issued by a probate registry, which authorises a named person to act as the personal representative of the deceased person.



required. Alternatively, the FIT installation may be transferred through the gift or sale of the land or building on which the FIT installation was attached. In this case, evidence could include the contract of the sale of the property which includes the installation, a fixtures and fitting form or confirmation from the personal representative that the installation was included.

6.25. The new FIT generator or the personal representative of the deceased FIT generator will need to submit a meter reading on the date of the transfer of the installation. This will be the date from which the new generator is entitled to receive payments.

6.26. The eligibility period or tariff rate will not be effected in anyway where right to claim FIT payments is transferred.

### **Notification of Distribution Network Operator**

6.27. FIT licensees should verify that the Distribution Network Operator (DNO) has been notified of details of MCS installations. This requirement is set out in legislation<sup>39</sup> and reflected in Engineering Recommendations.<sup>40</sup> Installers are required to notify DNOs and they should pass this evidence on to FIT generators. As a minimum, FIT licensees should include this as a check box in the application form to be completed and signed by the FIT generator. This declaration by the FIT generator is sufficient evidence for the verification purposes of the FIT licensee.

### **Meter checks**

6.28. All meters used in the FIT scheme must comply with the relevant metering legislation (see Appendix 11). Ofgem will verify meters of ROO-FIT installations during the ROO-FIT accreditation process, however FIT licensees must be satisfied that appropriate metering is in place before adding the installation to the CFR and commencing payments.

6.29. MPAN checking procedures should be put in place by FIT licensees and completion of these checks needs to be appropriately recorded in case of required provision for possible auditor review. This is especially important where the FIT generator is not a Supply customer of the Licensed Electricity Supplier.

6.30. Licensed electricity suppliers should note a generator's import supply meter may be affected by the installation of FITs generation: for example, an import supply meter that does not have a backstop fitted (so the import supply meter register rolls back when electricity is being exported), or a meter that is configured to treat exported electricity as imported electricity (so the exported electricity is added to the amount imported). Unless a generator

---

<sup>39</sup> Article 25 of The Electricity Safety, Quality and Continuity Regulations 2002

<sup>40</sup>G83 or G98 from 27 April 2019: <http://www.dcode.org.uk/annexes.html>

has offered to supply an appropriate meter themselves, the Licensed Electricity Supplier must ensure the installation and maintenance of an appropriate meter. We expect that where licensed electricity suppliers are notified of an issue with the import supply meters, they will take the necessary steps to investigate and resolve this at the earliest opportunity, treating consumers fairly, and in accordance with any relevant legislation.

6.31. Any Eligible Installation which does not have a generation and/or export meter that meets the required metering legislation should have their application declined until such a time as the necessary metering requirements have been met.

### **Electronic signatures**

6.32. Electronic signatures are allowable in place of a physical signature for all cases where a signature is required for correspondence between the FIT licensee and the generator.

6.33. Electronic signatures are data in electronic form which serve the same purpose as handwritten signatures – to associate the contents of a message with the sender. Examples of electronic signature include but are not limited to:

- scanned written signatures,
- type written signatures,
- cryptographically created signatures, and
- check boxes.

6.34. Should FIT licensees choose to allow electronic signatures, it is their responsibility to ensure they have sufficient assurance processes in place to manage fraud risk, as they should with physical signatures.

### **Nominated recipient**

6.35. Any assignment rights of a nominated recipient must be documented fully before placing such details onto the CFR. This should include: the nominated recipient's name, bank details and a declaration signed by the FIT generator stating the assignment of payments to the nominated recipient. Only a FIT generator can assign rights to FIT payments.

6.36. If a FIT generator wishes to add or change the nominated recipient details, they must notify the FIT licensee, and the FIT licensee needs to record this on the CFR. FIT licensees are required to follow their standard procedure for verifying data with the FIT generator (for example using a password when requesting the FIT generator to confirm personal details etc.) to ensure that the assignment is made by the FIT generator.

6.37. The nominated recipient cannot instruct the FIT licensee to make any changes to the FIT generator's or the accredited FIT installation's details.

### Meter details

6.38. FIT licensees must capture details of the generation and export meter as well as the import and export MPAN as appropriate, and record this on the CFR.

6.39. FIT licensees should check that any MPAN provided is valid and correct. Where the FIT licensee is the supplier for the MPAN we would expect a check to be made against their own records. Where they are not the supplier of the MPAN a check should be made against ECOES.<sup>41</sup> Alternatively FIT licensees should explore analytical techniques to scrutinise the MPAN, for example to ensure that the first 2 digits (Distributor ID) starts with a value in the range 10-28 as this refers to the Distribution Network Operator (DNO) or Independent Distribution Network Operator (IDNO). Values outside of this range are not a valid MPAN.

6.40. Checks should also be carried out to ensure that the MPAN meets the criteria under which it was generated. The final digit in the MPAN is the check digit and validates the previous 12 (the core) using a modulus 11 test. The check digit can be calculated by:

- multiplying the first digit by three,
- multiplying the second digit by the next prime number (five),
- repeat this for each digit (missing 11 out on the list of prime numbers for the purposes of this algorithm),
- add up all these products, and
- the check digit is the sum modulo 11 modulo 10.

6.41. FIT licensees are also required to obtain meter details for each meter used for the purpose of claiming FIT payments. An initial generation and/or export meter readings must be taken on or after the Eligibility Date (see Eligibility Date section, Chapter 7). For ROO-FIT installations, an initial generation meter reading will be captured by Ofgem, whereas FIT licensees will be required to obtain an initial export meter reading from the FIT generator during the application process. Start meter readings should be taken on the first day of the tariff period that the installation has gained entry into. Until it has been confirmed which tariff period this is, start meter reads should be taken on the first day of every tariff period.

---

<sup>41</sup> [www.ecoes.co.uk](http://www.ecoes.co.uk)

6.42. Electricity generated prior to an installation's Eligibility Date is not eligible to receive FIT payments. Accordingly, the initial meter reading(s) used to calculate FIT payments must not relate to an earlier date than the installation's Eligibility Date. Where a FIT licensee operates a postal application process, an initial meter reading that is supplied with a written request for MCS-certified registration of an installation that has been commissioned will usually relate to a date that is earlier than the installation's Eligibility Date. In such cases, that meter reading cannot be used as the initial meter reading for the purpose of calculating FIT payments and the FIT licensee will need to contact the applicant to obtain a meter reading that relates to a date on or after the date that the written application for MCS-certified registration was received by it.

6.43. If an export meter is installed at a later date, the FIT licensee should instruct the FIT generator to take an export meter reading on the day the export meter is installed. The FIT licensee is required to update the CFR accordingly. It should be noted that MPAN details are only required where the flow of electricity associated with a metering point is registered pursuant to the Balance and Settlement Code ie where the metering point is registered on ECOES. When entering details of export meters on the CFR, if the flow of electricity is not accounted for in settlement, then there may not be a MPAN for that export meter. If that is the case, licensees will instead be required to add the export meter serial number onto the CFR.

### Export status

6.44. Generators with the ability to export have to make an initial choice whether to receive the guaranteed export payment or to sell exported electricity on the open market. FIT licensees are required to explain this choice to FIT generators and record their decision on the CFR.

6.45. Generators who opt in to receive export payments from their FIT licensee will be unable to opt out and sell exported electricity on the open market, and vice versa, until at least the first anniversary of their participation in the scheme. After that date, FIT generators shall be permitted to change their selection to opt in or out, but no more than once every 12 months. FIT licensees are required to record this change on the CFR.

6.46. In circumstances where a FIT generator does not have the ability to export to a transmission or distribution network, they will not be required to make a choice at registration. They can defer such a decision until they have the necessary connection and equipment in place.

6.47. If an accredited installation with a total installed capacity of 30kW or less has an export meter commissioned, the export electricity from that installation will no longer be able to be deemed. The export meter must be able to measure the amount of electricity exported solely by the accredited FIT installation. Where an installation with a total installed capacity of 30kW

or less has co-located storage and a meter capable of measuring export (ie a smart meter), there are some instances where it may not be possible to isolate the export only from the FIT installation, and therefore it may continue to receive deemed export payments, Please see our [‘Guidance for generators: Co-location of electricity storage facilities with renewable generation supported under the Renewables Obligation or Feed-in Tariff schemes’](#) for more details. FIT licensees should notify Ofgem to update the CFR accordingly.

### Confirmation of registration

6.48. Once the FIT licensee has carried out all the required checks, it needs to register the Eligible Installation on the CFR.

6.49. An Eligible Installation will not be classed as accredited until the FIT licensee has received confirmation from Ofgem that the FIT Installation has gained entry into a tariff period and is then entered onto the CFR.

6.50. Once the registration process is complete, the confirmation email listing the key information about the accredited FIT installation will be sent to the FIT licensee. There will also be an onscreen confirmation that the installation has been registered.

6.51. Ofgem has facilitated the migration of certain micro-generators and small generators from the RO onto the CFR. Once completed, a confirmation email will be sent to the nominated FIT licensee. FIT licensees are then required to check with the FIT generator that the information held on the CFR is correct.

6.52. Once an installation is confirmed to be registered, the FIT licensee and FIT generator should agree a statement of FIT terms before FIT payments can begin.

### Statement of FIT terms

6.53. FIT licensees are required to take all reasonable steps to agree a statement of FIT terms with a FIT generator within ten working days of the confirmation date.

6.54. Following the receipt of a confirmation email from Ofgem, the FIT licensee should not delay agreeing the statement of FIT terms. If a FIT generator and FIT licensee cannot agree a statement of FIT terms, the FIT licensee should not begin FIT payments.

6.55. In certain circumstances, it may not be possible for the FIT licensee and FIT generator to agree a statement of FIT terms within the ten working day period. In such circumstances FIT licensees must continue to take all reasonable steps to agree the statement.

6.56. Once the statement of FIT terms has been signed the CFR must be updated to reflect this. If they are not signed within 12 months of the installation confirmation date the installation status on the CFR will become Dormant.

6.57. As a minimum standard, the statement of FIT terms is required to:

- be in writing,
- include the Principal FIT Licensee Terms and Principal Generator Terms (as detailed in Schedule A of the SLCs and reproduced in Appendix Three of this document), and
- take due account of the FIT Order and this guidance document.

6.58. In addition, the statement of FIT terms must include the following terms:

- A term which states that the information provided by the FIT generator or nominated recipient can be used for the purpose of administering, reporting and auditing the FIT scheme by the FIT licensee and Ofgem.
- A term specifically for off grid generators: "I hereby declare that it is my intention to use any and all electricity generated by my FIT installation and that I fully understand that any electricity generated but not so used will not be eligible for FIT payments".
- A term which requires FIT generators to notify the FIT licensee of any modifications, including any extensions, which may affect the eligibility and capacity calculation of an Eligible Installation.
- A term requiring the FIT generator to notify the FIT licensee of any modification of meters including if a smart meter has been installed
- A term requiring the FIT generator to notify the FIT licensee of the installation of a storage device
- A term requiring the FIT generator to make a declaration that the information they provide is complete and accurate.
- A term requiring generation and export meters to be located, where reasonable, in an accessible location, and for access to be made available to the FIT licensee or its contractor for generation and export meter readings.
- A term requiring the FIT generator to confirm that they are not in receipt of any grants which may make their installation ineligible for the FIT scheme.

- A term requiring the FIT generator to confirm that before they sign the statement of FIT terms and return it to the supplier that they have installed a FITs eligible technology and that it has been commissioned<sup>42</sup>.
- A term stating that any information provided by the generator to the FIT licensee may be shared with Ofgem or other such regulatory authority or government department and industry body for the purpose of administering, reporting and auditing of the FIT Scheme.
- A term requiring the FIT generator to retain information for the period of 1 year. The information should include all meter readings taken from or supplied by the FIT generator, including the Generation Meter Readings or Export Meter Readings supplied to the FIT licensee as part of the request for FIT payments in respect of the FIT installation; in addition to the details of all FIT payments made to the FIT generator throughout the period.

### Failure to agree a statement of FIT terms

6.59. In order to minimise the potential for the rejection of statement of FIT terms by the FIT generator, FIT licensees are strongly encouraged to explain to the FIT generator its obligations with regards to providing information and declarations and payment terms during the registration process.

6.60. FIT licensees should also look to accommodate the particular circumstances of a FIT generator if they believe it to be reasonable to do so.

6.61. If a FIT generator and a FIT licensee cannot agree the statement of FIT terms within ten working days, the FIT licensee may decide to discontinue the FIT registration process. The discontinuation of the registration process should be notified to the CFR Team at [FITRegister@ofgem.gov.uk](mailto:FITRegister@ofgem.gov.uk).

6.62. On discontinuing the registration process the FIT licensee is required to notify the FIT generator in writing, explaining the reason why the application is being discontinued and explain how the FIT generator can make a complaint against this decision.

6.63. The FIT generator should be advised that if they believe the FIT licensee is in breach of their obligations, they can make a formal complaint in writing to Ofgem's Compliance Team at

---

<sup>42</sup> For example, if solar PV is being installed the panels must already be in their final, permanent position, have been connected to the electricity supply by an MCS or equivalent registered installer and the meter must be fitted and operational. It should be made clear to the FIT generator that audit checks are in place to monitor scheme abuse.

[RECompliance@ofgem.gov.uk](mailto:RECompliance@ofgem.gov.uk) or RE Compliance Team, Ofgem, Commonwealth House, 32 Albion Street, Glasgow, G1 1LH.

6.64. If the FIT licensee wishes to discontinue an application, they should contact Ofgem. We will update the CFR to reflect that the FIT licensee is no longer acting in that role for that accredited FIT installation. Once the CFR has been updated, the FIT generator is able to approach an alternative FIT licensee for FITs. The FIT generator's Eligibility Date will not be affected.

### **Breaching the statement of FIT terms**

6.65. If a FIT licensee believes a FIT generator is in breach of the agreed statement of FIT terms, it should first look to remedy the situation with the FIT generator directly. However, if the breach continues and a resolution cannot be found, the FIT licensee should contact our CFR Team ([fitregister@ofgem.gov.uk](mailto:fitregister@ofgem.gov.uk)), and may be required to submit a 'FIT licensee Request for Ofgem Investigation' form (see [Appendix 12](#)).

### **Actions Ofgem may take against accredited FIT Installations**

6.66. Accredited FIT installations may be suspended or withdrawn from the FIT Scheme, or payments may be withheld if this is necessary for the appropriate administration of the scheme. If this occurs this will be reflected in the statuses for the installation on the CFR. We may also change the tariff code assigned to the installation, or attach or amend conditions of accreditation if considered appropriate. The following are some indicative examples of where one or more of these steps might be taken:

- We have good reason to believe that a situation detailed in the 'Ofgem powers relating to accredited FIT installations' section of Chapter four has occurred.
- We have good reason to believe that a FIT payment should not have been made.
- Abuse of the FIT scheme is suspected.
- A statement of FIT terms has been breached.
- A FIT generator has not provided its FIT licensee with necessary information (for example, has not participated in the annual data check exercise).

6.67. Please note that where a Statement of FIT Terms has been breached or a FIT generator has not provided necessary information, the FIT licensee should first look to resolve the issue directly with the FIT generator. Only where a resolution is not forthcoming should the issue be brought to our attention.



6.68. FIT licensees are required to promptly inform our CFR team when they have reason to believe an error has occurred in relation to the eligibility of an accredited FIT installation. The FIT Compliance team should be contacted if there are any concerns in relation to FIT Payments and the Levelisation process. FIT licensees should attempt to remedy any errors before the next FIT payment is due. If appropriate, we may suspend the relevant installation on the CFR or confirm payments should be withheld until the error has been corrected or any investigation into suspected abuse has been concluded.

6.69. When scheme abuse is suspected, FIT licensees should discuss with our FIT Fraud Prevention & Audit Manager any actions the FIT licensee intends to take.

6.70. In cases where any of the situations detailed in the 'Ofgem powers relating to accredited FIT installations' section of Chapter four, may have or are believed to have occurred, the role of the FIT licensee will be to promptly liaise with our CFR team about the nature of the issue or irregularity. Dependent on the circumstances, the FIT licensee should ensure they have carried out their own investigations and then provide this information to us by submitting a 'FIT licensee Request for Ofgem Investigation' form as required (see [Appendix 12](#)).

6.71. Where we have been informed of a suspected issue, we may if appropriate proceed to investigate the matter further. The FIT licensee should be prepared to investigate the situation further themselves and provide clarification and evidence to assist our investigation.

6.72. Where we have carried out an investigation and consider it appropriate to take any of the actions detailed in the 'Ofgem powers relating to accredited FIT installations' section of Chapter three the FIT generator and licensee will both receive formal notification from Ofgem. This will include the decision reached, action to be taken, the date from which that action will apply, and any resulting impact on payments. Dependent on changes made to the installation on the CFR, an automated email may also be received by the FIT licensee notifying them of the update made.

6.73. FIT licensees shall not make any FIT payments to a FIT generator or nominated recipient if we inform the FIT licensee that an accredited FIT installation has been suspended or withdrawn from the FIT scheme. If suspension is revoked, we will again write to the FIT licensee and FIT generator confirming that the suspension has been revoked, and the date from which that revocation takes place.

6.74. FIT licensees should be aware that where issues are reported and investigated on those accredited FIT installations that have been extended; we may consider it appropriate to take action concerning only part of an installation's capacity (ie the original or an extended capacity). Where this action requires that FIT payments are withheld, only such payments for electricity generated by the relevant part should be withheld. However, the FIT generator will only be

able to continue to receive payments for the other capacity installed on the site if metering arrangements allow for separate, accurate metering of the remaining capacity. If this is not possible then FIT payments to the whole installation will need to be withheld until such time as the detected issue is resolved or separate metering is installed.

### Extension Rules and additional capacity

6.75. Any extension to an accredited FIT installation that is commissioned on or after 15 January 2016 is not eligible for FIT payments. This applies to both generation and export payments.

6.76. If FIT licensees are informed that an installation has been extended and the commissioning date of this extension means that it is ineligible for payments, then they should contact the CFR team to inform them of this change.

6.77. If an accredited installation and an ineligible installation share the same meter then it is possible to pro-rate the meter readings taken from this meter.

6.78. In instances where two accredited installations share the same meter and one becomes ineligible for FITs, eg because the eligibility period of the original installation has come to an end, it is possible to pro-rate meter readings using the shared meter.

### **Extension rules for FIT-accreditation with extensions commissioned before 15 January 2016**

6.79. If the maximum capacity of the same technology type on a site exceeds the upper limit placed on Eligible Installations (5MW of total installed capacity for all technologies except for CHP, where the maximum limit is 2kW), the extended installation will become ineligible for FIT payments. The installation may then be eligible for other schemes, such as the RO. Where this occurs, the FIT licensee is required to notify Ofgem, who will remove the installation from the CFR.

6.80. Multiple installations of the same technology type commissioned on the same date on the same site will usually be regarded as one FIT installation. We refer to these installations as having "additional capacity". This is an administrative term we use to describe this scenario, which is explained in greater detail below. Such a FIT installation will have one tariff rate based on the total installed capacity of all installations. The same generation meter can be used to record the amount of electricity generated from all installations. Where there are multiple installations of the same technology type commissioned on the same date on the same site, one of them should be registered as normal on the CFR and the other parts of the installation (i.e. the additional capacity) should be added as if they were extensions. The CFR will automatically calculate the appropriate tariff code.

6.81. Multiple installations of the same technology type commissioned at different times but on or before the application date on the same site will usually be regarded as one FIT installation. This is also referred to as “additional capacity”. Such a FIT installation will have one tariff rate based on the total installed capacity of all installations. The same generation meter can be used to record the amount of electricity generated from all installations.

6.82. Additional capacity is treated as one FIT installation and, for installations with an application date before 15 January 2016, will share the same eligibility date, eligibility end date and tariff code. The additional capacity should be added to the CFR in the same way as extensions are recorded (i.e. they will have the same FIT ID but separate extension references). The CFR will identify that the different capacities should be treated as part of the same installation and will assign the eligibility date, eligibility end date, tariff code and tariff rate.

6.83. All accredited FIT installations sharing the same meter should be registered with the same FIT licensee. To ascertain whether there are any installations on one site sharing the same meter, FIT licensees should search for other installations at the same address. If a match is found and they are not the FIT Licensee of the match, the FIT licensee is required to contact the CFR Team.

6.84. If a FIT licensee suspects that an error has been made and an installation has been extended but not reported, the FIT licensee should withhold FIT payments to that installation and undertake further investigation into the possible error. The FIT licensee should also inform Ofgem of the suspected error – the CFR Team to update the status and the FIT Fraud Prevention and Audit Manager. If no error has been made, or the error has been corrected ie the extension has been notified and the CFR updated, the FIT licensee should notify Ofgem and resume making FIT payments in accordance with the installation's entry on the CFR.

### **Same Technology Type Extensions with extensions commissioned before 15 January 2016**

6.85. If an extension had been commissioned before 18 October 2011 and notified to Ofgem before that date, it will be treated in accordance with the rules set out in the 'FIT Supplier Guidance (Version 1)':

- An extension to an Eligible Installation will be classed as being part of the original installation if commissioned within 12 months of the original installation's confirmation date (or commissioning date for the installations installed prior to 1 April 2010). The extension will have the same Eligibility Date and eligibility period as the original installation. The combined installation will be treated as having a new total installed capacity. If the extension moves the combined installation's capacity to another tariff

band, the whole installation will receive the lower tariff from the extension's Eligibility Date.

- An extension to an Eligible Installation commissioned more than 12 months from the Eligible Installation's confirmation date (or commissioning date for those installations installed prior to 1 April 2010) will be treated as a separate installation, except when determining a total installed capacity.

6.86. From 18 October 2011, if an installation has been extended by increasing its capacity to generate electricity using the same technology type, extensions will be treated as a separate installation, except when determining a total installed capacity.

6.87. The original installation will retain its tariff rate and eligibility period, but the extension will have its own eligibility period and tariff rate.

6.88. The Eligibility Date for the extension will be based on its commissioning date only, as the application date is that of the original installation. This means that different eligibility periods may apply to different components of an accredited FIT installation. Payments to the extension will accrue from its Eligibility Date; therefore, the start generation meter reading must be captured on the Eligibility Date.

6.89. The tariff rate for the extension will be based on the combined capacity of the extended installation.

6.90. Both the original installation and subsequent extensions will share the same entry on the CFR. They will have the same FIT ID but separate extension references.

6.91. If the original installation and extension share the same generation meter, a pro rata calculation from the generation meter reading taken on the extension's Eligibility Date should be used to determine how much electricity generated is assigned to each part. The CFR contains details on how generation payments should be split for multiple installations using the same generation meter. The same applies for export from the original installation and extension.

### **Extension rules for FIT-accreditation with application date on or after 15 January 2016**

6.92. Any extension to an accredited FIT installation that is commissioned on or after 15 January 2016 is not eligible for FIT payments. This applies to both generation and export payments.

6.93. However, for installations with an application date on or after 15 January 2016 where the multiple installations are on the same site, of the same technology, commissioned on the same day or different days, but before the application date, these installations will be regarded

as the same installations and referred to as “additional capacity”. This means they will share the same eligibility date, eligibility end date and tariff code and tariff rate.

6.94. The CFR does not allow for this type of additional capacity to be added as an extension. FIT Licensees are therefore unable to register this type of additional capacity themselves. Instead they should contact Ofgem on [FITRegister@Ofgem.gov.uk](mailto:FITRegister@Ofgem.gov.uk) and request the changes on the CFR to update the TIC for the existing installation. The CFR will then calculate the correct tariff rate and tariff code for the installation. FIT Licensees are required to provide an MCS certificate with the details for the installation at the point of contacting Ofgem. Ofgem will verify this and save the certificate on the CFR. The FIT Licensee should also update the metering details of the installation through the CFR.

### **Same Technology Type Extensions to non-FIT Installations**

6.95. Where a FIT generator wishes to add additional capacity of the same technology type to an existing installation that is not eligible for the FIT scheme, FIT licensees should treat the extension as a new application to the FIT scheme in accordance with Chapter three.

6.96. The extension tariff rate will be based on the combined capacity of all commissioned installations of the same technology type on that site, including non-FIT installations.

### **Different Technology Type Extensions**

6.97. In circumstances where an accredited FIT installation has been extended with a different technology type, the extension will be treated as a separate installation. FIT licensees should treat the extension as a new application to the FIT scheme in accordance with Chapter four.

6.98. Payments to the extension will accrue from its Eligibility Date. The start generation and/or export meter reading must be captured on the Eligibility Date.

6.99. In circumstances where two different technologies share the same generation meter, eligible generation will be pro-rated between the installations in proportion to their TICs. This should be applied to all generation from the generation meter reading captured on the extension’s Eligibility Date. This is equally true in the case of Export meters.

## Switching

6.100. All FIT licensees have a duty to facilitate the switching of a FIT generator from one FIT licensee to another and ensure the FIT services are appropriately managed during this process.<sup>43</sup> The CFR facilitates the switching process.

---

<sup>43</sup> Principal Generator Term under clause 6.3.2(c) of the SLCs

6.101. When approached by a FIT generator requesting a switch, a FIT licensee shall check the status of the accredited FIT installation the FIT generator wishes to switch on the CFR. More details on this can be found in the Central FIT Register User Guide.<sup>44</sup>

6.102. The CFR will indicate whether there are any other accredited FIT installations on the same site. If there are, the FIT licensee is then required to contact Ofgem's CFR Team to confirm whether any meter sharing arrangements occur on that site. Ofgem will provide the FIT licensee with FIT IDs of all installations sharing the meter as the FIT licensee should ensure that all installations sharing the same meter are being switched. Ofgem will monitor whether all installations sharing the same meter have switched to the same FIT licensee.

6.103. If the FIT generator's current FIT licensee gives consent to the switch, both FIT licensees shall agree the switch date and a generation and/or export meter reading on that date.

6.104. During the process the new FIT licensee should ensure that it has received all the necessary information about the FIT generator. Most of the information is available on the CFR, however, the previous FIT licensee should pass on any other relevant information during the switching process. This may be information outside the register (eg email) and needs to include the following:

- when the export opt in/opt out choice has last been made,
- in the case of half-hourly export metering, what arrangements are in place to capture the meter readings, and
- copy of the relevant declarations (for example, grants and multi-installation declaration).

6.105. The new FIT licensee has rights to object to the switch if the key information is missing, eg the FIT generator has not had its meter verified as required. If both FIT licensees express no objections to the switch throughout the process, they and the FIT generator will be notified once the switch is complete.

6.106. The previous FIT licensee shall be obliged to pay all FIT payments due to the FIT generator up to the switch date. FIT licensees should ensure that the closing generation meter read and, where relevant, export meter read with the existing FIT licensee matches the opening meter read(s) with the new FIT licensee.

6.107. The new FIT licensee shall be obliged to pay all FIT payments from the switch date. The new FIT licensee shall have the responsibility for amending the CFR to reflect the fact that the

---

<sup>44</sup> [www.ofgem.gov.uk/FITs](http://www.ofgem.gov.uk/FITs)

switching process is completed by adding the generation meter read and, where relevant, the export meter read on the switch date.

6.108. Once the switch has completed, a new Statement of FIT Terms should be agreed between the new FIT licensee and the FIT generator. The new FIT licensee shall follow the same process regarding registration and statement of FIT terms as discussed above.

6.109. Further information on the switching process for licensees, and who can facilitate it, can be found in CFR User guide.<sup>45</sup>

---

<sup>45</sup> <https://www.ofgem.gov.uk/FITs>

## 7. FIT payments

### Chapter summary

This chapter provides guidance on making and calculating FIT payments.

### Eligibility Date

7.1. FIT payments to an accredited FIT installation should commence from the Eligibility Date.

### MCS installations

7.2. For installations (except for community energy and school installations) with MCS certificate issue dates on or after 15 January 2016 the Eligibility Date will be the later of:

- the application date to the FIT licensee, and
- the start of the tariff period that the installation falls into.

7.3. For installations with MCS issue dates of before 15 January 2016, the Eligibility date will be the later of:

- the date of receipt by a FIT licensee of a FIT generators written request for MCS-certified registration, accompanied by an MCS Certificate for the installation, and
- 1 April 2010.

### ROO-FIT installations

7.4. The Eligibility Date for FIT applicants with RO or ROO-FIT accreditation will be determined by Ofgem in accordance with the definition of the Eligibility Date. It will be stated both on the CFR and in the RO migration or ROO-FIT accreditation letter.

7.5. For installations where an application for full ROO-FIT accreditation is submitted on or after 15 January 2016 the Eligibility Date will be the later of:

- the date that the application is submitted<sup>46</sup> via the Renewables and CHP Register, and
- the start date of the tariff period that the installation falls into.

---

<sup>46</sup> An application is considered submitted once the application has been completed and submitted to Ofgem. The applicant must then go on and agree the declarations associated with the application.



7.6. The eligibility date for a ROO-FIT installation where a preliminary accreditation is converted to full and installation is commissioned within the validity period will be the later of:

- the date we received the application converting the preliminary accreditation to full accreditation, and
- the commissioning date.

7.7. The Eligibility Date for community and school installations is explained in chapter 3.

7.8. During our assessment of an application for accreditation, we will request independent verification that the installation in question has been commissioned. This information will be assessed against the definitions in the FIT Order and Schedule A to Standard Licence Condition 33 of the Electricity Suppliers' Licence. Such verification could take the form of:

- notice from the Distribution or Transmission Network Operator that the installation was permitted to export to the grid, for example witnessed G59/99 test documentation (or equivalent), or correspondence from the Distribution or Transmission Network Operator confirming that these tests do not need to be witnessed,
- confirmation from the installer as to the date on which the installation was commissioned, and/or
- an audit report from an independent party that attests to when the installation was commissioned and the configuration of the installation at the relevant date.

7.9. Receipt by a FIT licensee of 'a FIT applicant's written request for MCS certified registration' means receipt of:

- MCS certification,
- name and address of generator,
- site of the installation (physical location and MPAN if applicable),
- name and address of nominated recipient (if applicable).

7.10. This would constitute sufficient information to assign an application date. It is not necessary for the licensee to receive other documents or certificates such as the EPC in order for the application date to be assigned. (Although receiving an EPC with the application will assist toward the prompt determination of the application).

7.11. It is also strongly recommended that, if applicable, a valid EPC, signed declarations, and information around grants are received early in the application process to allow FIT licensees to accurately assess eligibility under the scheme.

7.12. Applicants are also required to provide proof of ownership of the installation to demonstrate they are the owner of the installation and therefore entitled to claim FIT Payments. This is not required to set an eligibility date, but is required as part of the application process in the same way as EPCs and declarations.

7.13. Applications should not be added to the CFR until all information has been received from the FIT generator and assessed by the FIT licensee.

7.14. A FIT applicant must have a compliant meter in place for FIT payments to be made.

### Eligibility Period

7.15. The Eligibility Period means the maximum period during which a FIT generator can receive FIT payments for an Eligible Installation, as set out in the table of Annex 1 to the SLCs. The Eligibility Period begins on the Eligibility Date and differs in length depending on when an accredited FIT installation was commissioned, when an application was received and the technology type installed. It will be determined by Ofgem based on the information provided and stored on the CFR.

7.16. For the majority of installations this is 20 years (10 years for micro CHP).

### Installations transferring from the RO

- The Eligibility Period for micro-generators commissioned before 15 July 2009 and transferring from the RO will expire on 31 March 2027.
- The eligibility period for micro-generators commissioned between 15 July 2009 and ending on 31 March 2010 will expire on 31 March 2035 for PV, 31 March 2030 for Wind, Hydro and AD and 31 March 2020 for Micro CHP.
- The eligibility period for small generators commissioned between 15 July 2009 and 31 March 2010, shall expire on 30 September 2034 for PV and on 30 September 2029 for Wind, Hydro and AD.

7.17. The "eligibility period" for community energy installations that have pre-registered commences on the installation's commissioning date.

7.18. The "eligibility period" for ROO-FIT installations that have received preliminary accreditation will begin on the "eligibility date". The eligibility date is the later of the date the installation commissioned and the date the application converting the preliminary accreditation to full accreditation was received by Ofgem.

7.19. The end of the Eligibility period is calculated by the CFR. FIT licensees can view it for accredited FIT installations which they have registered.

7.20. To avoid confusion, we recommend that FIT licensees contact generators prior to the end of their eligibility period to confirm the date on which an accredited FIT installation's accreditation and FIT payments will cease.

### Nominated Recipient

7.21. The FIT generator is able to assign FIT payments to a nominated recipient in respect of an accredited FIT installation owned by that FIT generator.

7.22. The nominated recipient is permitted to provide generation and/or export meter readings in respect of an accredited FIT installation they have been nominated to receive FIT payments for.

7.23. If the nominated recipient suspects fraud or abuse of the scheme regarding the FIT generator or the FIT licensee, they should contact Ofgem's FIT Fraud Prevention and Audit Manager.

### Tariff Rates

7.24. The FIT tariff rates are provided in the SLCs.

7.25. For MCS installations, whether or not an installation qualifies under a cap and is eligible for a particular tariff rate will be determined by the MCS certificate issue date. The tariff rate will also be determined by the:

- Eligible Low Carbon Energy Source,
- Total Installed Capacity,
- the energy efficiency requirement (if applicable),
- the multi-installation tariff (if applicable), and
- other characteristics relevant to the accredited FIT installation.

7.26. The tariff rate for ROO-FIT installations which have submitted an application for accreditation on or after 15 January 2016 will be based on the date and time of their application and the corresponding cap that the installation falls into. The tariff rate will also be determined by the:

- Eligible Low Carbon Energy Source,
- Total Installed Capacity,
- the energy efficiency requirement (if applicable),
- the multi-installation tariff (if applicable), and

- other characteristics relevant to the accredited FIT installation.

7.27. For installations with MCS issue dates and ROO-FIT application dates of before 15 January 2016, tariff rates are allocated to each accredited FIT installation based on the following:

- Eligibility date,
- Eligible Low Carbon Energy Source,
- Total Installed Capacity,
- The Tariff Date,
- The energy efficiency requirement (if applicable),
- The multi-installation tariff (if applicable), and
- Other characteristics relevant to the accredited FIT installation.

7.28. FIT payments must be made at the rates set out under the FIT payment rate tables in Annexes 2 to 4A to the SLCs. However, if a FIT licensee wishes to make additional payments to FIT generators and nominated recipients as a commercial matter outside of the statutory FIT scheme, any such payments should be identified separately in any communication with FIT generators and nominated recipients (eg itemised separately within their bill), and any such payments must not be included within the FIT licensee's levelisation notifications to Ofgem.

7.29. Both generation and export tariff rates are index-linked, which means that they increase and decrease with inflation. The tariff rates are adjusted annually as specified in the SLCs by the percentage increase or decrease in the Retail Price Index (RPI) over the 12-month period ending on 31 December of the previous year.

7.30. From 1 April each year, all generation and export tariffs for existing installations will be amended to take into account RPI adjustment. However, existing installations with a Tariff Date between 1 January and 31 March in the preceding FIT year will not have their generation tariff adjusted by RPI until the following year. Export however, will continue to be adjusted by RPI. Tariff rates for new installations set out in the SLCs will also be adjusted by RPI on 1 April each year.

7.31. To ensure the correct tariff is applied to all generation and export from 1 April each year, FIT licensees are required to calculate what proportion of electricity has been generated and/or exported until 31 March, and what proportion has been generated and/or exported from 1 April. To facilitate the process FIT licensees may ask FIT generators and nominated recipients to take a reading on 31 March and submit it in accordance with the FIT licensee's instructions. We

would strongly encourage FIT licensees to use reads on 31 March, if appropriate Half Hourly (HH) data is available.

7.32. Tariff information is available from Ofgem's website.<sup>47</sup>

### FIT Payments

7.33. FIT payments are normally due to the FIT generator or nominated recipient from the Eligibility Date for the entirety of the eligibility period unless:

- the payments are withheld,
- the FIT Installation is suspended from the CFR,
- the accredited FIT installation is withdrawn or removed from the CFR, or
- the FIT generator terminates their participation in the scheme,

7.34. FIT licensees are not obligated to make FIT payments to a FIT generator or nominated recipient until:

- they are first satisfied that the information given by the FIT generator or third party is accurate and the Eligible Installation meets the necessary FIT requirements (Chapter four),
- the Eligible Installation has the appropriate metering (Appendix Ten),
- the Eligible Installation has the necessary entry on the CFR and the FIT licensee has received a confirmation email from Ofgem (Chapter six), and
- a statement of FIT terms has been agreed between the FIT licensee and the FIT generator (Chapter six).

7.35. Because FIT payments accrue from the Eligibility Date, the generation and/or export start meter reading provided by the FIT generator needs to be taken on the Eligibility Date to ensure that the FIT generator is paid for the duration of the eligibility period. For all technologies excluding AD, where a meter reading is not available on the Eligibility Date the reading must be the next reading taken after that date. Meter readings for AD installations must be taken on the Eligibility Date or they may have their generation payments adjusted.

---

<sup>47</sup> [www.ofgem.gov.uk/FITs](http://www.ofgem.gov.uk/FITs)

7.36. Where settled export meters are used, the Balancing and Settlement Code (BSC) requires FIT licensees to put in place arrangements which would allow them to capture and record the amount of electricity being exported during the period for which payments are made.

7.37. When considering the costs associated with settled metering, FIT licensees should consider the cost of ongoing operation and maintenance against the benefit to them from settling the flow. They should then consider the net costs/benefits and the effect this will have on their own consumers. Once these considerations have been taken into account, the licensee is free to choose how such costs should be passed on.

7.38. Where a licensee intends to pass on the costs of settled metering to the generator, the licensee is to make the generator aware of the costs so that the generator can make a considered decision on whether or not to opt-in or out of FIT export payments or negotiate a price for the exported electricity on the open market.

### Tolerance Checks

7.39. FIT licensees' obligations include implementing processes to detect abnormal generation and/or export meter readings before making FIT payments. Generation and export meter readings given by or on behalf of FIT generators should be assessed against expected generation. If generation and/or export meter readings are noticeably different from the expected generation, FIT licensees must query the generation and/or export meter reading. Under these circumstances, FIT licensees must undertake increased monitoring of the relevant installation and consider if there is an error in the information given by the FIT generator, or possible abuse of the scheme.

7.40. FIT licensees must fulfil this obligation by taking consideration of capacity/load factors based on the following:

**Table 5: Technology type and tolerance level considerations**

Technology	Considerations when determining tolerance levels
PV	Solar radiation varies seasonally over the year, but it can be assumed that PV panels will not operate at full capacity for more than an average 12 hours a day. We would expect tolerance levels to be lower than other technology types due to higher predictability of solar input, in comparison to other environmental factors.
Wind	Wind energy generation varies regionally, with those installations in northern regions of the UK/elevated locations experiencing greater wind input. It is advisable to consider regional location of wind installations to determine relative

	tolerance levels. Seasonal and exceptional weather variations (such as storms) may also be factored in to tolerance levels.
Hydro	Meter reads from hydro installations will typically exhibit considerable seasonal variation. For reads over the winter we would advise a higher tolerance level.
Anaerobic Digestion	It is expected that generation from anaerobic digestion will vary. Generation will be linked to the calorific value of the biogas which is broadly based on the feed stocks added to the digester.
Micro CHP	There are many different variables that may affect electrical output. Therefore, it would not be appropriate for Ofgem to provide guidance on tolerance levels for micro CHP installations.

7.41. Total installed capacity along with technology must be included in tolerance levels.

7.42. Larger installations should have a lower tolerance level than smaller installations of the same technology. This is to minimise potential error in relation to these installations' comparatively substantial FIT payments.

7.43. However, FIT licensees may prefer to include additional checks on meter reads that result in substantial FIT payments, rather than vary tolerances within a certain technology.

7.44. Additionally, FIT licensees should consider incorporating the following factors related to the installation into their processes:

7.45. Estimated Annual Generation (this can be established from MCS records)

7.46. Historical meter reads. It is advisable to compare meter reads of an installation with the previous year's reads during their second FIT year and beyond, as this may highlight any anomalous recordings. Consequently, for the duration of the first FIT year for an installation this method will not be possible but referring to similar installations in nearby locations may be appropriate.

7.47. Seasonal variations in generation, where appropriate tolerance levels may vary quarterly. In some instances, it may be advisable to request a weather report or other suitable verifiable evidence from generators after they have experienced adverse weather conditions, such as a storm causing increased wind/hydro energy generation, which can be kept on record and thus help explain any reads which fall outside of tolerance levels.

7.48. Photographs can be used to verify aspects of the installation metering details. It is advisable that after the second instance of a reading which falls outside of tolerance levels, the

Supplier requests a photograph of the meter reading, with proof of the date, as well as a photograph of the installation itself to confirm capacity (ie to verify the number of PV panels on a roof). The photograph of the meter is to confirm whether the meter has been miss-read or if there are any other discrepancies with the meter read.

7.49. This does not alter our guidance on verifying meter reads at least once every two years, which does not allow photographs instead of other checks. (See Chapter seven for more detail)

7.50. After considering both a weather report or other evidence and photographs of the meter and installation, it may be necessary to complete a further audit of the installation.

7.51. Supplier audits of generation and/or export meter readings should be proportionate to the level of abnormal readings, and can range from desk based investigation to onsite visits.

7.52. It may be beneficial to monitor the number of abnormal readings submitted, noting each occurrence on the generators record and referring to a tiered approach (see overleaf).

7.53. For onsite visits it may be beneficial to send a “technical” representative to the installation address to check that the meter is operating correctly, to confirm the capacity and to ensure that the meter is being read accurately by the generator.

7.54. The feedback from this check should be analysed, to decide upon the next appropriate step.

7.55. If an error is identified, the FIT licensee must inform Ofgem and undertake further investigation. Ofgem may put the FIT installation under investigation on the CFR whilst the investigation takes place. The FIT licensee must withhold FIT payments to the FIT generator until the investigation is complete.

7.56. We advise that you communicate with the Ofgem FITs Compliance and Fraud team members in this instance, in order to take the appropriate action with the generator

7.57. If no error has been made, or the error has been corrected, the FIT licensee should notify Ofgem to update the CFR and should resume FIT payments in accordance with the installation’s entry on to the CFR.

**Figure 6: Tiered Response Plan for Abnormal Readings**



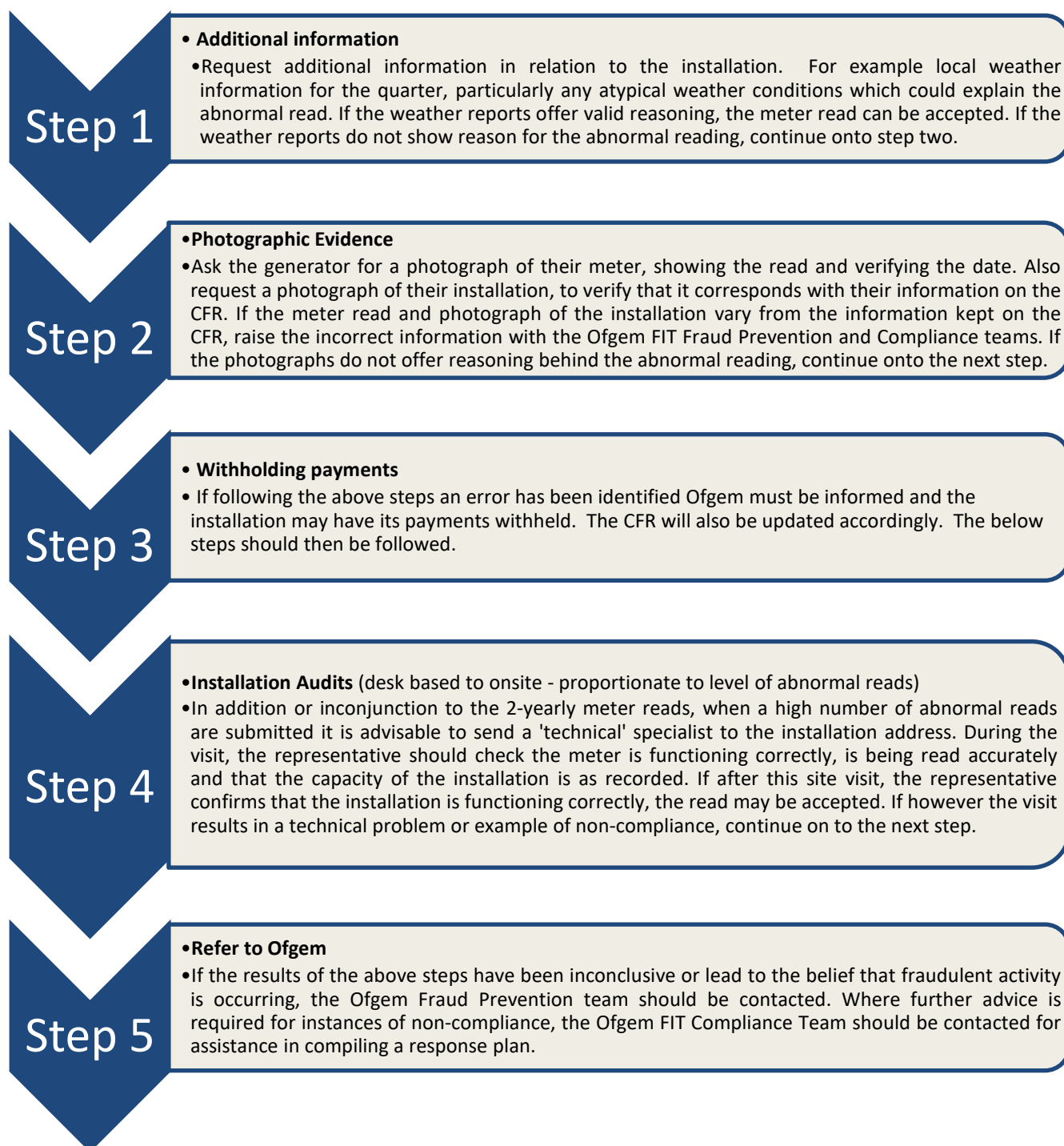

7.58. Figure 6 is an example plan. We expect all suppliers to compile their own appropriate response plan, which should be readily accessible for auditing.

7.59. The SLCs are relevant conditions for the purposes of the Electricity Act 1989. Ofgem monitors FIT licensees' compliance with such conditions. As part of this duty, Ofgem will conduct sample reviews and inspect the processes FIT licensees have in place to demonstrate compliance is appropriate, including the tolerance controls and auditing procedures that suppliers have implemented to detect, monitor and investigate abnormal meter readings.

7.60. With regard to the process of monitoring and investigating abnormal readings, it is important that FIT licensees retain clear records of all the readings that have been flagged as exceptions and the actions that have been taken to resolve/conclude each instance. This will ensure there is a clear audit trail.

### Calculation of Generation Payment

7.61. Unless a FIT generator exports all electricity, a generation meter reading is a prerequisite for eligibility for FIT generation payments. Suppliers should take all reasonable steps to ensure that generators are aware of the frequency at which they are required to provide generation meter readings.

7.62. The FIT licensee should use generation meter readings, given by the FIT generator or nominated recipient, to determine the amount of electricity that has been generated in the relevant period.

7.63. FIT generation payments must be paid on the basis of actual meter readings from the installation, estimated generation is not permitted under the scheme.

7.64. The FIT licensee should then calculate how much generation payments are due to the FIT generator or nominated recipient by reference to the relevant tariff code and the amount of electricity that has been generated.

7.65. The FIT licensee should then make a generation payment to the party identified on the CFR as being the payee. This could either be the FIT generator or the nominated recipient.

### **Generation payments for AD installations**

7.66. AD generators that made a new application for ROO-FIT preliminary accreditation or full accreditation on or after 1 May 2017 will have to comply with sustainability criteria. These generators will also be subject to feedstock restrictions and reporting requirements which may impact their FIT generation payments. FIT export payments will not be affected by these new requirements.

7.67. These generators are required to take generation meter readings on a quarterly basis that will align with the sustainability and feedstock reporting requirements.

7.68. Unless otherwise specified, generation meter readings must be taken in line with the quarterly meter reading timetable which will start from the installation's Eligibility Date.

7.69. These meter readings must then be submitted to the FIT licensee within 28 calendar days from the end of each quarterly period.

7.70. For example, if an AD installation's Eligibility Date is 4 January 2018, the first quarterly reporting period will start on 4 January 2018 and end on 3 April 2018. Meter readings should be taken on these dates, and the deadline for submitting the meter reading to the FIT licensee will be 1 May 2018.

7.71. Where a generator submits generation meter readings that were not taken on the start and end of a quarterly period, the FIT licensee shall calculate the electricity generated in that reporting period by pro-rating with reference to the available meter readings.

### Calculation of Export Payment

7.72. In order to receive export payments, the FIT generator must have the ability to export and have opted in to receive export payment from the FIT licensee. A FIT generator is not entitled to export payments, if it does not have the ability to export electricity or has chosen to negotiate a price for the exported electricity on the open market.

7.73. Where it is not possible or practical to measure export by export meter readings, deeming is permitted for accredited FIT installations with a total installed capacity of up to 30kW. For the accredited FIT installations where export is permitted to be deemed, the Secretary of State determines the percentage of electricity deemed to be exported. Such a determination is published at least 1 month before the beginning of each FIT Year.

7.74. An accredited FIT installation with a total installed capacity of over 30kW must have an export meter to receive export payments from the FIT licensee. Where applicable, the FIT licensee should make the FIT generator aware of the requirements of export metering under the BSC and the potential financial cost of ongoing management of their installation.

7.75. Where an export meter is installed, the FIT licensee can elect to register it with the relevant Meter Point Administration Service (MPAS) so that the flow can be accounted for pursuant to the BSC for the purpose of settlement. Such registration is the responsibility of the FIT Licensee. Should the export not be accounted for in settlement, then the export meter may not have a MPAN associated with that metering point (see chapter six).

7.76. The FIT licensee should use export meter readings or deemed export meter readings, given by the FIT generator or nominated recipient, to determine the amount of electricity that has been exported in the relevant period.

7.77. The FIT licensee should then calculate how much export payments are due to the FIT generator or nominated recipient by reference to the relevant tariff code and the amount of electricity that has been exported or deemed to have been exported.

7.78. The FIT licensee should then make an export payment to the party identified on the CFR as being the payee. This could either be the FIT generator or the nominated recipient.

### Reducing, Recouping and Withholding FIT Payments

7.79. FIT licensees have an obligation to take all reasonable steps to ensure any FIT payments made reflect only that to which FIT generators or nominated recipients are entitled to.

7.80. If a FIT licensee believes that in making a FIT payment it would contravene their obligations, it is required to notify Ofgem's FIT Compliance Manager/FIT Levelisation and Degression Manager immediately<sup>48</sup>. If Ofgem determines that a FIT payment could result in the improper administration of the FIT scheme, it may put the accredited FIT installation under investigation and withhold payments on the CFR.

7.81. FIT payments may be reduced, recouped or withheld by the FIT licensee if:

- An error has been made by the FIT licensee, Ofgem, or the FIT generator, as a result of which a FIT generator or nominated recipient has received a payment to which it is not entitled.
- Ofgem notifies the FIT licensee that it has good reason to believe that a FIT payment should not have been made.

7.82. FIT generation payments for new AD installations from 1 May 2017 may only be reduced, recouped or withheld by the FIT licensee in respect of a failure to comply with the sustainability criteria, feedstock restrictions or reporting requirements, if:

- Ofgem has good reason to believe the generator is not entitled to full FIT generation payments,
- The generator does not make any representation or objections to demonstrate otherwise, and
- Ofgem gives notice to the FIT licensee with the amount of generation payments that should be reduced, recouped or withheld.

7.83. Further information on reasons for withholding, reducing or recouping FIT generation payments for AD installations can be found in Feed-in Tariffs: Guidance on sustainability criteria and feedstock restrictions.

7.84. If instructed to withhold payments, the FIT licensee shall continue to do so until notified by Ofgem that the withholding of payments has been rescinded, or if instructed by Ofgem to recover or make a reduced FIT payment.

---

<sup>48</sup> [RECompliance@ofgem.gov.uk](mailto:RECompliance@ofgem.gov.uk)

7.85. Ofgem will only instruct FIT licensees to recover payments, if they were the relevant FIT licensee when the overpayment was made.

### Biennial Verification of meter readings

7.86. FIT licensees are required to take reasonable steps to verify generation and/or export meter readings, at least once every two years from the installation's confirmation date. This will be monitored by Ofgem.

7.87. We expect that FIT licensees or their agents will verify meter readings using one of four methods:

- **Method One:** Physically reading meters.
- **Method Two:** Using historical data to corroborate submitted meter readings.
- **Method Three:** Auditing systems to ensure no changes have been made to the system.
- **Method Four:** Using generator-submitted photographic evidence.

7.88. Best practice procedures for each method are at Appendices [Four](#), [Five](#), [Six](#) and [Seven](#) respectively.

7.89. The first and fourth methods are the only methods we would expect licensees to undertake for meters that do not have automatic meter readers (AMRs). The other methods may only be used for meters that have AMRs.

7.90. Licensees should document which meters have been verified, the reading/actions taken and when. These records should be available for auditing by Ofgem or any organisation working on behalf of Ofgem. Dates of verification are to be recorded on the CFR by the licensee.

7.91. When registering for the FIT scheme, FIT applicants should be made aware that to continue to be eligible for FIT payments, generation and/or export meters must be in an accessible location and the FIT generator will be expected to take reasonable steps to allow access to them. The FIT licensee's verification method does not relieve the FIT generator of these obligations in anyway.

7.92. The agreed statement of FIT terms should set out these responsibilities and also the possible consequences of not complying with these requirements such as withholding FIT payments. FIT licensees may also wish to include a section in the Statement of FIT Terms that amplifies what is required of the FIT generator to facilitate AMR biennial meter verification.

7.93. We do not expect FIT licensees to read meters if they are prevented from accessing the meter by unreasonable actions taken by the site owner or tenant, or if accessing the meter contravenes recognised health and safety standards. We do however, believe it is reasonable

for licensees to put in place measures that ensure their representatives are able to enter loft spaces with the use of ladders and a torch. We would not expect meter readers to cross un-boarded loft spaces, or similar, whilst attempting to read meters. Equally, if using method 4, licensees should not ask generators to provide photographic evidence where it would be unsafe for them to access the meters.

7.94. Where licensees do encounter meters in locations they believe contravene MCS installation guidelines, they should report the facts to MCS and/or RECC. The FIT Compliance Team can provide further guidance on this ([recompliance@ofgem.gov.uk](mailto:recompliance@ofgem.gov.uk)).

7.95. We do not expect licensees use methods two and three (of verification) to verify AMR meter readings if the generator has not been able to satisfactorily demonstrate that their meters have an AMR capability. In the event of the generator not being able to show that their meters are AMRs, then methods one or four should be used for biennial meter verification.

7.96. Where it has not been possible to read or verify a generation and/or export meter, the FIT licensee should issue a warning to the FIT generator, reminding them of the agreed statement of FIT terms and the possibility of FIT payments being withheld. FIT licensees should then contact Ofgem and provide full details of any concerns with respect to the FIT installation's continued registration on the CFR. If the circumstances require, Ofgem may consider exercising its powers to further investigate the FIT Installation and withhold payments.

7.97. FIT licensees must inform Ofgem of any installations, which they have not been able to verify by the last working day of the first month of each quarter. Licensees should submit this information to [recompliance@ofgem.gov.uk](mailto:recompliance@ofgem.gov.uk). Further details on the process can be found in Appendix 15.

7.98. Before notifying us of unverified installations, licensees should take all reasonable steps to achieve verification in line with our best practice guidance. Please refer to Appendices Four, Five, Six and Seven.

7.99. We expect that where an installation has an AMR (and have satisfied the Licensee to this effect) the licensee will attempt verification using all four of the methods. The licensee is free to decide the order in which they use those methods to attempt verification.

7.100. We welcome suggestions from any interested parties as to other methods that could achieve verification. We will assess each suggestion on its merits and will update our guidance if required.

### **Use of Automatic Meter Readers for biennial meter verification**

7.101. The use of automatic meter readers (AMRs) within the FIT scheme has been happening for some time. They are generally used where the FIT generator (owner) does not occupy or own the Site with which the FIT Installation is associated. This means the FIT generator has the ability to monitor how much electricity is generated and, where applicable, exported without the need to visit the site regularly.

7.102. FIT licensees are encouraged to seek confirmation as early as possible on whether an installation uses AMRs. Licensees should consider requesting this in their application forms when a FIT generator applies to a FIT licensee for FIT Payments. In the case of large multi-site generators (MSGs), we would expect FIT licensees to discuss the requirements for biennial meter verification and reach an approach that suits both parties. If a FIT generator does not initially inform their FIT licensee that their installation has an AMR, the FIT licensee will need to give careful consideration to which method of biennial meter verification is suitable.

7.103. FIT licensees are expected to have in place processes that allow them to identify whether an installation meets the requirements for AMR verification.

7.104. It should be noted that it is meter readings, rather than the AMR, that are subject to biennial meter verifications. This means that if the AMR is changed, added or removed at any point in the two-year period, the period for verification is not reset.

### **FIT Export meters registered pursuant to the Balance and Settlement Code**

7.105. In the case of FIT Export meters that are registered pursuant to the BSC, FIT licensees should use method two for verification. This involves review of DA/DC data for the purposes of achieving biennial meter verification. Meters that are registered pursuant to the BSC are required to comply with BSC protocols which, in most cases, exceed the requirements in this guidance. DA/DCs are independently qualified and certified and operate to industry-wide standards. The settlement data provided by DA/DCs for FIT export meters is more than acceptable for historical verification purposes.

### **Determining what is an AMR**

7.106. AMRs provide measured electricity generation for multiple time periods (ie for each half hour) and provide the owner with remote access to that data. For FITs, the measured electricity is the amount of Generation and/or Export. An AMR should be able to send data to a remote location securely and all components of the system should be intrinsically linked. They should have some means of automatically capturing, retrieving and storing energy metering data electronically.

7.107. An AMR will essentially consist of three components:

- the meter,
- a means of storing data, and
- a means of communicating data.

7.108. The three core components should all be linked by electrical wiring so they form the essential nature of the AMR within one unit. As such, the removal or failure of any one of these components would prevent the AMR acting as a remote meter reading function. The composition of these three components should allow data to pass safely and securely between the three units.

7.109. AMRs should be installed by an accredited installer, ideally at the same time as the rest of the installation. Further details on how an AMR is formed (ie how the three components fit together) will be available from the manufacturer's specifications. The FIT licensee should request the FIT generator provides this information in order to determine whether AMR data verification is possible.

7.110. We do not consider meters that use impulse loggers, calibration LED pickups and other such sensors (which do not have intrinsically linked components) to reach the level of accuracy needed to provide accurate sources of data. Therefore, they will not be considered compliant FIT AMRs.

### **Integrity of AMR data**

7.111. FIT licensees should request that FIT generators who wish to use AMRs demonstrate that the integrity of their AMR data means that it can be accepted as a suitable substitute for physical verification. To do this, they should demonstrate that the means by which data is collected, handled and passed to the FIT licensee is as close as practicable to the standards used by DA/DCs<sup>49</sup> for half-hourly data. We would expect licensees to use their knowledge of the supply market in this respect.

7.112. Elsewhere in the electricity industry, supply and export data is handled by suitably qualified DA/DCs whose certification gives confidence in the accuracy of the data. There is a concern that data from unqualified AMR meter service providers (MSP) may be corrupted. If

---

<sup>49</sup> Data Aggregator/Data Collector – collects HH metering data from source, conducts checks and passes to relevant parties. The standards and minimum qualifications for DA/DCs are laid down by Elexon in the BSC



there is any concern about the integrity of a FIT generator's AMR data, then the licensee should be guided by their own knowledge and the DA/DC data practices when assessing suitability.

7.113. If further assurance is required, where possible, the FIT generator should be requested to provide the data required for verification method three (corroboration of historic data) whilst the FIT licensee is assessing their AMR suitability. If the data passes the audit, then the FIT licensee should assume that the AMR data provided is correct and there are no data integrity issues.

### **Physically reading AMRs to deter potential Fraud**

7.114. Two-year meter verification is an essential counter fraud tool. There is a risk that FIT generators could claim for generation that hasn't occurred. In order for an AMR to be an acceptable substitute for physical or photographic verification, FIT licensees should conduct a physical or photographic meter read (ie methods one or four) at 5% of AMR installed sites that would otherwise be verified using methods two or three. This will provide assurance that the AMR data relates to accredited FIT installations. When conducting sampling reads, FIT licensees ensure the following:

- FIT licensees are to physically or photographically read 5% of each of the MSGs to which they make payments.
- All AMRs that do not belong to a MSG are to be considered as one collective. Of this collective, 5% are to be physically read.
- When selecting installations to be physically or photographically read, FIT licensee should select those with the greatest cause for concern.
- Amongst the factors that may cause FIT licensees concern are inaccurate quarterly (or otherwise) meter submissions; late submissions of data if a specific submission time is agreed; and reticence on behalf of the FIT generator to supply reasonable information. This is not an exhaustive list; other factors may also be considered.
- If a FIT licensee has so few installations of concern, the remaining sites should be randomly selected so that the 5% requirement is satisfied (being mindful of the technology representation requirements below).
- The sample of physical reads undertaken should be representative of technology type. If an MSG has 80% solar PV installations, then of those selected for a sample physical read, 80% should be solar PV and the remaining 20% made up of the other technologies owned by that MSG. The same principle applies to the non-MSG collective mentioned previously.

7.115. We recommend that FIT licensees plan ahead when selecting sites to sample check. We expect that 5% of all AMR installations due for a verification each quarter would be sample checked. FIT Licenses may roll over some sample checks. However, by the end of the FIT year, of all AMRs that were due a biennial verification, 5% are to have been subject to a sample read.

7.116. FIT licensees are to retain records of all sample reads undertaken. Such documentation may be requested for the purpose of audit in line with any other records maintained by FIT licensees.

7.117. Should there be any concern about AMR data arising from the 5% sample checking, we should be contacted for further guidance. Where an AMR is not accessible for sample checking, it should be treated in the same way as a non-AMR installation.

### AMR data models

7.118. There is currently no definitive standard for energy meter Data Models (the means by which data is recognised and packaged within an AMR system) in the UK. There are a lot of different models in use that conform to numerous different standards. As there is no one definitive standard to compare others against, there is no clear way to determine what standard AMRs should comply with for data modelling. Because of these reasons, AMRs are not required to meet specific requirements for data modelling.

### AMR communication methods

7.119. The AMR can transmit data to the generator through a number of methods. By far the most common method is General Packet Radio Service (GPRS) followed by Global System for Mobile communications (GSM) dial-in. We consider that the following means of communication are acceptable for data transmission:

- **Mobile network data services** – the use of mobile telecommunications for transferring meter readings. This includes the use of GPRS, GSM and Short Messaging Service (SMS).
- **PSTN data calls** – traditional modem calls over the analogue telephone network. These are generally used by larger sites where a dedicated analogue telephone line is available.
- **Integrated services data network (ISDN)** – two 64k digital channels that can be used to make two calls simultaneously. This method is generally used by larger sites with dedicated ISDN lines.
- **Packet Radio Service (Paknet)** – is operated under an Ofcom licence, allowing exclusive use of a range of VHF radio channels in the UK.

- **Long-range radio** – generally using mesh radio technologies. Some smart metering communication service providers are using this technology as a backup in areas of poor primary communication coverage.
- **Circuit switched mobile data services (CSD)** – digital modem call from the FIT generator's back-end system. CSD services are being reduced but they are sometimes used as a backup communication method.
- **Local area networks** – several devices connect to a communications gateway that provides a connection to the FIT generator's back-end systems over a wide area network (WAN).

7.120. Any other system that is able to provide a similar level of reliability of continuity of transmission to those mentioned above should be acceptable. Any generator proposing another method should be asked to demonstrate its suitability. It is recommended that licensees build their own records of acceptable systems in a similar way that many licensees have their own database of acceptable meter serial numbers.

7.121. This list is in no way exhaustive. Should a FIT licensee have any doubt about a means of communicating data that is not on the above list, they should contact Ofgem for further guidance.

7.122. Where possible, AMRs should have a secondary means of communication. However, this is not always practical or cost effective and is not an essential criterion. If a secondary means of communicating is fitted, it should meet the same criteria as mentioned above.

7.123. As most AMRs will not have a secondary means of communication, there should be a way for the FIT generator to access meter data. The meter should at least have a physical display. This will also allow the FIT licensee to conduct physical meter verification if Methods two and three are not appropriate or possible.

7.124. FIT generators whose installations use AMRs should have a system through which they are able to show the relationship between SIM cards, meter serial numbers and MCS certificates (in order to determine the location of the AMR). They should be able to identify at any given time exactly which SIM card is inserted into which AMR installation and the location of that installation. This is critical as many AMR back-end systems use the SIM card number to identify the AMR when attempting to exchange data. By ensuring that their systems are fully up to date, FIT generators can ensure there is no possibility that the wrong meter readings have been assigned to the wrong installation.

7.125. FIT licensees should request FIT generators provide sufficient evidence to demonstrate their processes and systems are satisfactory. Examples of how they can do this include:

- submission of procedural documents,
- approval records for when changes have been made to the system,
- screen captures of the records held by the FIT generator,
- standard operating procedures agreed with/supplied by, a third party Meter Service Provider,
- a visit to the FIT generator by the FIT licensee or their representative, or
- a combination of any or all of the above.

7.126. For AMRs that do not use SIM cards, but do have another means of uniquely identifying the AMR, similar systems and processes should be in place.

### AMR Communication and Physical Security

7.127. Standard meter and communication protocols support a number of security provisions, offering varying degrees of protection and complexity to manage. The simplest form of protection is a simple password system. AMR systems should contain the minimum four-level password system that is accepted practice in the UK. In reality however, we understand that the fourth-level may only be held by the manufacturer. An example of how the four levels may appear is shown in Table 6:

**Table 6: Four level password system**

Level	Application	Access
One	Read identification, basic metrology registers, clock and alarms	Read only
Two	Update time/date and billing reset (eg maximum demand)	Limited write
Three	General access to configuration and recording functions. Modification of password levels 1-3	Read/write
Four	Calibration, measurement transformer ratios and setting passwords	Write

7.128. FIT generators should be requested to demonstrate to the FIT licensee how they meet or surpass this minimum level of security. We would expect evidence to be in the form of manufacturer's specifications. Other means may include screen captures of computer screens showing requirements for password entry into secure systems. If in doubt, licensees should be guided by industry best practice and if necessary, seek further guidance from Ofgem.

7.129. We recommend that AMRs should be sealed composite units or fitted with appropriate industry accepted security seals (eg metal mousing wire or security stickers). However, this is not always practicable as it is onerous to retro-fit for those AMRs already installed. Given the low risk of tampering, we would only recommend this as best practice and not as a requirement.

### **System Monitoring and Fault Finding**

7.130. FIT licensees should request that any FIT generator that is considering using AMRs should establish that there is a minimal risk of data being incorrect due to data faults. Ofgem considers that industry practices in relation to meter fault rectification are such that it should be possible for FIT generators to establish this to FIT licensees' satisfaction.

7.131. The means by which fault finding and continuous monitoring are conducted varies; a variety of systems are in place that allow for remote diagnosis of metering systems before resorting to site visits. Many providers have implemented pro-active generator notification for performance issues that exceed tolerable limits. Examples include e-mails, SMS text messages, phone calls and website service area updates. It is our understanding that many generators have their own timelines in which any faults need to be rectified in order to provide assurances for their interested parties (eg investors).

## 8. Modifications to accredited installations

### Chapter summary

Provides guidance on how to deal with installations that have been modified.

8.1. For general information on making amendments to the Central FIT Register (CFR), please refer to the CFR user guide. If you require a copy, please contact the CFR team at [fitregister@ofgem.gov.uk](mailto:fitregister@ofgem.gov.uk).

8.2. We recommend that you request written confirmation of any modification to an accredited installation.

### Decommissioning

8.3. If a FIT generator notifies you that they have decommissioned the accredited installation, you must update the CFR to reflect this.

### Extensions and reductions

8.4. An extension or reduction is a modification to an accredited installation to increase or decrease its TIC from the same type of eligible technology (eg solar PV or wind).

8.5. It is the FIT generator's obligation under the statement of FIT terms to notify you if they extend or reduce the TIC of the accredited installation (by adding, removing or replacing generating equipment). Once they do so, you must update the CFR to reflect this.

8.6. Modifications to TIC do not affect the tariff rate of the accredited installation.

8.7. If an extension does not have a separate generation or export meter, readings must be prorated according to TIC to ensure the generator is paid correctly. For example, if a 40kW installation has been extended by 10kW:

- and the extension is accredited, the generator is entitled to payment for 80% of the electricity they generate and export at the tariff rate(s) of the original installation and 20% at the tariff rate(s) of the extension
- and the extension is **not** accredited, the generator is only entitled to payment for 80% of the electricity they generate and export

- 8.8. An accredited installation and any extensions must not exceed 5MW in combined TIC (or 2kW for micro-CHP). If they do, they are no longer eligible for the scheme and you must notify Ofgem who will remove the installation from the CFR.

### Generating equipment

- 8.9. The replacement of generating equipment does not, in itself, affect the compliance of the accredited installation, however it may affect its TIC.
- 8.10. Generators may temporarily remove an accredited installation from site without affecting its compliance (for example, during roof repairs).

### Other modifications

- 8.11. The generator should notify you if a generation or export meter has been replaced, removed or begins measuring electricity that is not generated by the accredited installation.
- 8.12. If the installation was accredited under MCS-FIT, the generator should also notify you of any other modifications to the accredited installation.

### Moving FIT Accredited Installations

- 8.13. In some circumstances, it is possible to move FIT accredited equipment and then return it to the same location without affecting the FIT accreditation – eg if the roof is being replaced. That is on the provision that there were no modifications made to the installation. The installation would be composed of the same equipment, located at the same address and have the same grid connection.
- 8.14. The generator cannot claim FIT payments while the works are taking place, as the installation would not be generating any power.
- 8.15. Were the installation modified in some way, for example by increasing the capacity, consideration would need to be given to how those changes impacted the 'eligible installation' and whether those changes impacted the FIT accreditation.
- 8.16. We would not expect FIT licensees to provide a formal view to the generator until the works have been fully completed. All changes made to a FIT accredited installation should be made on a case-by-case basis.
- 8.17. If an installation is moved from its site, for example where its owner takes it to a new property, it will no longer be eligible. The licensee must notify Ofgem who will withdraw its accreditation.

## **Re-allocating Capacity to Another (Second) MPAN**

8.18. We encourage FIT licensees to bring cases where a 'site' of an installation has been amended to our attention. Such circumstances must be assessed on a case by case basis and there are no general indicators or positions that we have identified in this respect at this time. If appropriate we will issue further guidance.

## **Changes to MCS Certificates**

8.19. The MCS certification forms a vital part of the initial application for the FIT scheme. At the point of registration on the Central FITs Register (CFR) the MCS certificate should be a true reflection of the installation to allow validation of the information at the point of entry into the FIT scheme.

8.20. If any information contained within the certificate submitted with the FIT generator's request for MCS-certified registration is found to be incorrect, it should be corrected regardless of the length of time since the original was issued. We would expect FIT licensees to request FIT generators to update their MCS certificate in this scenario.

8.21. When requesting a change to MCS certificates, FIT licensees should provide clear information and any supporting evidence to justify why a change is necessary to the FIT generator. Further guidance and clarity on the evidence required is provided in



8.22. Table **7** below.

8.23. For any alterations to the installation after the point of entry to the scheme, which would cause the information contained within the MCS certification to be outdated, we would not expect FIT licensees to request it be updated. For example, new Generation Meter serial number, change in supply MPAN, reduction in capacity, etc. We would expect FIT licensees to request objective evidence of these changes through the usual routes of invoices, photographs, etc., to satisfy themselves that the information they hold on the installation is accurate. Based on this information they should then update the CFR.

8.24. Sections 8.24 to 8.27 above should be read in conjunction with sections 6.4 to 6.8 of this document which set out specific rules around MCS certificate checks under deployment caps.

**Table 7 - Evidence required for changes to MCS Certificates**

Field	Evidence required	Notes
<b>Site details</b>		
Address	Suitable forms of evidence include: <ul style="list-style-type: none"> <li>an invoice from the MCS certified company showing the correct address, and/or</li> <li>written confirmation from a third party (such as a FIT licensee) of the correct address.</li> </ul>	
Supply MPAN	Suitable forms of evidence include: <ul style="list-style-type: none"> <li>a copy of the electricity bill, and/or</li> <li>written confirmation from a third party (such as a FIT licensee) of the correct MPAN.</li> </ul>	An MCS certificate is valid without an MPAN. However, if an incorrect MPAN appears on the MCS certificate and requires amendment, the electricity supplier can request in writing that the MPAN is updated. If ECOES is not updated, then the MCS installer will add the MPAN manually.
<b>Generation meter details</b>		
Generation meter make	Clear photographic evidence may be accepted.	Generation meter details may only be amended if the incorrect details were entered onto the certificate initially. No changes will be made if a generation meter is replaced.
Generation meter model	Clear photographic evidence may be accepted.	
Generation meter serial number(s)	Clear photographic evidence may be accepted.	

Generation meter reading	Cannot be amended as it is not possible to supply valid evidence of the meter reading at commissioning.	
<b>Installation details</b>		
Commissioning date	<p>Suitable forms of evidence include:</p> <ul style="list-style-type: none"> <li>• proof of grid connection from Distribution Network Operator (DNO) (electricity only), and</li> <li>• dated paperwork from installer such as a commissioning certificate.</li> </ul>	<p>Commissioning date may only be changed where there is clear evidence that the commissioning date was entered incorrectly by the installer. If there is any doubt, then the date should not be altered.</p> <p>Since November 2013 the MCS database will not allow an installer to amend the commissioning date if the date is more than ten working days in the past. The MCS installer must contact MCS and MCS will make a case by case judgement.</p>
Total installed capacity (kW)	<p>Suitable forms of evidence include:</p> <ul style="list-style-type: none"> <li>• installer paperwork such as a commissioning certificate.</li> </ul>	
Declared net capacity (kW)	<p>Suitable forms of evidence include:</p> <ul style="list-style-type: none"> <li>• installer paperwork such as a commissioning certificate.</li> </ul>	
Installation type	<p>Suitable forms of evidence include:</p> <ul style="list-style-type: none"> <li>• installer paperwork such as a commissioning certificate, and/or</li> </ul>	Standalone = not wired to provide electricity to a building.

	<ul style="list-style-type: none"> <li>written confirmation from a third party (such as the DNO or FIT licensee) of the correct MPAN.</li> </ul>	
<b>Product details</b>		
Technology type	<p>Suitable forms of evidence include:</p> <ul style="list-style-type: none"> <li>installer paperwork such as a commissioning certificate.</li> </ul>	

8.25. Changes to an MCS certificate are not permitted if the details were correct at the time of commissioning. Subsequent changes to an installation do not require an amendment to the MCS certificate.

## 9. Levelisation Process

### Chapter summary

This chapter details the levelisation process in the FIT scheme.

### General Principles

9.1. The levelisation process is the mechanism by which the cost of the FIT scheme is apportioned across Licensed Electricity Suppliers. The cost is apportioned based on each supplier's share of the Great Britain electricity market, whilst taking into account any FIT contribution they have already made.

9.2. The general principle of the Levelisation process is that all active Licensed Electricity Suppliers are required to participate in the levelisation process by:

- providing information to Ofgem to enable us to administer the process, and
- making levelisation payments as requested by Ofgem.

9.3. In order to determine whether a Licensed Electricity Supplier will have to make a levelisation payment or whether a FIT licensee is entitled to levelisation payments, Ofgem must determine and compare each Licensed Electricity Supplier's market share contribution and adjusted FIT contribution.

9.4. If the Licensed Electricity Supplier's adjusted FIT contribution exceeds the amount of that Licensed Electricity Supplier's market share contribution, the licensee will receive a levelisation payment. If, however, the licensee's adjusted FIT contribution is less than that licensee's market share contribution, the licensee will be required to make a levelisation payment.

9.5. A FIT Licensee will not be treated as a licensee for the purposes of any periodic levelisation, annual levelisation or mutualisation which takes place after the termination of its licence. Therefore, if a Licensed Electricity Supplier has its licence revoked before any periodic levelisation, annual levelisation or mutualisation has taken place, then that supplier will not form part of the market share calculation, nor will their FIT contribution be included.

9.6. If a Licensed Electricity Supplier has its licence revoked after we have determined that a supplier is liable to make a payment in to the periodic or annual levelisation fund, then that supplier will remain subject to that liability. If we have determined that a supplier is entitled to

receive a payment from the periodic or annual levelisation fund, that supplier will remain entitled to such part of that payment as the Authority shall determine.

### Market Share Contribution

9.7. The market share contribution of a Licensed Electricity Supplier means the sum of all FIT contributions by all FIT licensees adjusted by the Licensed Electricity Supplier's market share.

9.8. The market share of a Licensed Electricity Supplier is determined by calculating the amount of electricity supplied to customers in Great Britain by the Licensed Electricity Supplier, less the exempt amount supplied to qualifying Energy Intensive Industries (EIIs). This is then compared to, and expressed as a percentage of, the total relevant electricity supplied by all licensed electricity suppliers in Great Britain.

9.9. Licensees must report on the total amount supplied to relevant EIIs and the amount of this which is exempt, based upon the level of exemption each meter receives. More information on supply data can be found in Appendix 8.

9.10. Between FIT Year 7 and 13 inclusive (1 April 2016 – 31 March 2023) the amount of electricity sourced from renewable sources generated outside of the UK can be exempt from a Licensed Electricity Supplier's market share.

9.11. Renewable electricity generated overseas and supplied in GB may only be exempted from a Licensed Electricity Supplier's supply for FIT levelisation purposes in FIT Years 7 to 13 if it meets the definition of 'qualifying renewable electricity'. That is electricity that is:

- produced from renewable sources,<sup>50</sup>
- generated in a Member State of the EU,
- generated by a generating installation which had a capacity less or equal to 5MW, and
- generated by a generating installation which became operational on or after 1st April 2010.

9.12. Renewable electricity generated between 1 August 2015 and 31 March 2023 from both EU Member States and from outside of the EU should be evidenced by GoOs.<sup>51</sup> After this time

---

<sup>50</sup> As defined in regulation 2(1) of the Electricity (Guarantees of Origin of Electricity Produced from Renewable Energy Sources) Regulations 2003

<sup>51</sup> The only non-EU countries that suppliers have presented LECs for historically have been Norway and Switzerland, both of which issue GoOs.

this energy will no longer be exempted. The process for submitting GoOs is that used for Fuel Mix Disclosure (FMD).

9.13. From FIT Year 10 to 13 inclusive the overall cap on the amount of overseas renewable electricity that can be exempted from supply for levelisation purposes is that applied in the previous FIT year multiplied by 1.1.

9.14. The following rules apply until the end of FIT Year 13:

- If the cap is not breached, all eligible GoOs presented for FMD are used as evidence of the amount of supply that may be exempted for FIT levelisation.
- If the cap is breached, Ofgem's FIT team calculate the volume of supply that each FIT licensee may exclude for FIT levelisation based on the following calculation.<sup>52</sup>

$$\text{exempt supply volume} = \text{cap} \times \frac{\text{number of eligible GoOs presented by licensee}}{\text{total number of eligible GoOs presented by all licensees}}$$

9.15. For any GoOs to be considered as evidence of exempted electricity for FIT Year 13, these need to be recognised by Ofgem and held by the FIT licensee at midday on **1 July 2023** for the period April 2022 – 31 March 2023. After this time GoOs will not be recognised, and exemptions will no longer apply. Our GoO recognition guidance can be [found here](#).<sup>53</sup>

### FIT Contribution

9.16. The FIT contribution means the sum of the following FIT payments and costs incurred:

- generation payments,
- net deemed export payments,
- (from 1 April 2019) net metered export payments and
- qualifying FIT cost.

9.17. The "adjusted FIT contribution" means the FIT contribution adjusted by the amount of periodic levelisation payments and mutualisation payments (if applicable) received or made by the licensee in the FIT year.

---

<sup>52</sup> See article 27A of the FIT Order.

<sup>53</sup> GoOs may be submitted on 1 July 2023 to evidence qualifying renewable electricity in FIT year 13 (see paragraph 9.10)

### Export Payments

9.18. Net (metered and deemed) export payments means payments to a FIT generator or nominated recipient in respect of the export less the value to the FIT licensee of that export.

9.19. For each FIT year, the Secretary of State determines the value of net metered and net deemed export one month before the beginning of that FIT year.

9.20. The value of net deemed export has been determined to be the amount of electricity deemed to have been exported by all accredited FIT installations multiplied by the System Sell Price (SSP), and this value needs to be apportioned to each Licensed Electricity Supplier in accordance with its market share.

9.21. Ofgem determines the value of deemed export during each levelisation process. This includes calculating the SSP.

9.22. From 1 April 2019, the value of metered export is included in the levelisation calculation and is the amount of electricity exported by metered FIT installations multiplied by the System Sell Price (SSP). This value is apportioned to each Licensed Electricity Supplier in accordance with its market share.

9.23. Deemed export is apportioned in levelisation relative to the total amount of deemed export claimed under the scheme. From 1 April 2019, metered export is apportioned relative to individual suppliers' amount of metered export paid for.

### Qualifying FIT Costs

9.24. The value of the qualifying FIT costs is determined annually by the Secretary of State. The costs are determined on a per installation basis and are separated into 'new generator costs' and 'ongoing generator costs'. Additionally, the costs are separated into 'large' and 'small' FIT licensee categories, which may vary how much is received per generator.

9.25. 'New generator costs' are associated with an installation which is identified on the Central FIT Register as an accredited installation for the first time. Whereas 'ongoing generator costs' ('existing installations' on the CFR) are associated with an installation which remains accredited on the Central FIT Register. 'Ongoing generator costs' are applied in the first quarter of the FIT year to all installations.

9.26. During the levelisation process, the CFR will display how many installations are eligible for the qualifying FIT costs and how much the FIT licensee is entitled to claim. When a new installation is registered on the CFR as an accredited installation, the cost associated with it will be the sum of the 'new generator cost' and the 'ongoing generator cost'. However, to prevent double-counting this will be displayed only under the 'new' installations total.



9.27. When a FIT generator switches from one FIT licensee to another, the new FIT licensee will receive the 'ongoing generator cost' in the Levelisation quarter in which the switch is completed. Whereas the previous supplier will retain any new or ongoing costs already allocated to it in the year.

9.28. The Annual Secretary of States Determinations sets out the value of the costs each year and this is published on the Department for Energy Security and Net Zero website by 1 March each year for the subsequent year.

### Periodic Levelisation

9.29. Ofgem is required to undertake the levelisation process on a periodic basis. Periodic levelisation will take place quarterly with each period beginning and ending as follows:

- 1 April - 30 June.
- 1 July - 30 September.
- 1 October - 31 December.
- 1 January - 31 March.

### Periodic Levelisation Report

9.30. FIT licensees should provide the following information in their periodic levelisation reports:

- Total value (GBP) of FIT generation payments claimed by FIT generators and nominated recipients following the submission of valid generation meter readings during that periodic levelisation period.
- Total value (GBP) of deemed FIT export payments claimed by FIT generators and nominated recipients following the submission of valid generation meter readings during that periodic levelisation period.
- For levelisation periods from 1 April 2019, total value (GBP) of metered FIT export payments claimed by FIT generators and nominated recipients following the submission of valid export meter readings during that periodic levelisation period.
- Total amount (MWh) of electricity deemed to have been exported by FIT generators and nominated recipients following the submission of valid meter readings during that periodic levelisation period.

- Total amount (MWh) of metered electricity exported by FIT generators and nominated recipients following the submission of valid meter readings during that periodic levelisation process.

9.31. The following components of the periodic levelisation report will be determined by the CFR:

- Total number of installations eligible for the qualifying FIT costs in that periodic levelisation period.
- Total value of (£) qualifying FIT costs that FIT licensees have incurred in respect of FIT installations in that periodic levelisation period.

9.32. In addition, all Licensed Electricity Suppliers shall provide Ofgem with details of the total electricity they have supplied in Great Britain for that periodic levelisation period. The total electricity supplied in Great Britain should be determined using the same methodology as the one used under the RO. As part of the periodic levelisation submission, Licensed Electricity Suppliers can declare the amount of supply to Energy Intensive Industries.

9.33. From FIT Year 7 (2016-17), where a licenced supplier has not supplied electricity within the relevant quarter (ie zero supply), it will no longer be obligated to make a levelisation submission to Ofgem on the Central FIT Register, unless that licence is also a FIT licensee and has associated payment data for the relevant quarter.

9.34. Where a formally dormant licence begins to supply, the RE Compliance team should be informed as soon as possible, to ensure that the Central FIT Register is set up to allow for the licence to make a submission during the next levelisation process.

9.35. Information submitted as part of a periodic levelisation process is required to be based on FIT payments which have been claimed by generators or nominated recipients in the periodic levelisation period following the submission of valid meter readings. The payments do not have to be audited, or reflect what have been received by FIT generators and nominated recipients, or completely reflect electricity which has been generated by FIT Installations in that particular periodic levelisation period.

9.36. FIT licensees are not required to submit FIT Payment information to Ofgem every periodic levelisation. However, as a minimum, the levelisation process cannot be fully undertaken without each Licensed Electricity Supplier confirming its market share therefore the minimum requirement is for licensees to submit their supply data.

### Periodic Levelisation Schedule

9.37. There are four stages to the levelisation schedule:

- FIT licensees are required to send a periodic levelisation report regarding a periodic levelisation period.
- Ofgem will make the necessary calculation and notify each Licensed Electricity Supplier whether a levelisation payment is owed by them, or due to them.
- Licensed Electricity Suppliers are required to make any levelisation payments due to Ofgem.
- Ofgem will make levelisation payments due to FIT licensees, subject to any shortfall in the levelisation fund.

9.38. For the dates and deadlines of the Levelisation schedule, please refer to the 'Feed-in Tariffs Levelisation Schedule' for the relevant FIT year on our [website](#).

### Periodic Levelisation Calculation

9.39. For periods before 1 April 2019: Following the submission of the data applicable to that period, Ofgem will calculate that a Licensed Electricity Supplier's periodic levelisation payment shall be equal to:

$$plp = \{ms \times [tgp + tdep - (ade \times SSP) + tqc]\} - [igp + idep - (ade \times SSP \times ms) + iqc]$$

9.40. For periods from 1 April 2019: Following the submission of the data applicable to that period, Ofgem will calculate that a Licensed Electricity Supplier's periodic levelisation payment shall be equal to:

$$plp = \{ms \times [tgp + tdep - (ade \times SSP) + tmep - (ame \times SSP) + tqc]\} - [igp + idep - (ade \times SSP \times ms) + imep - (ime \times SSP) + iqc]$$

- plp - Licensed Electricity Supplier's periodic levelisation payment (£)
- ms - Licensed Electricity Supplier's market share
- tgp - total (£) generation payments
- tdep - total (£) deemed export payments
- ade - total (MWh) amount of electricity deemed to have been exported
- SSP - System Sell Price (£/MWh)
- tmep - total (£) metered export payments
- ame - total (MWh) amount of metered exported electricity
- tqc - total (£) qualifying FIT costs

- igr - individual (£) generation payments
- idep - individual (£) deemed export payments
- imep – individual (£) metered export payments
- ime – individual amount (MWh) of metered exported electricity
- iqcc - individual (£) qualifying FIT cost

### Annual Levelisation

9.41. Annual levelisation begins on following the end of a FIT year and is to be completed by 1 October. It is a requirement that data regarding FIT payments made to FIT generators submitted in the annual levelisation process is fully audited by a third party.

9.42. Data provided by FIT licensees to Ofgem for the annual levelisation process should be fully audited prior to submission. The report must be prepared by a person that is independent of the supplier. This means an auditor who is not part of the structure of the organisation, or a third party body contracted to provide the audit report. The requirements of the annual levelisation audit will be provided by Ofgem on an annual basis. The terms of reference for the annual levelisation audit will be circulated by 31 May each year.

### Annual Levelisation Report

9.43. FIT licensees should provide the following information in their annual levelisation reports:

- Total value (GBP) of FIT generation payments made to FIT generators and nominated recipients following the submission of valid generation meter readings during that FIT year.
- Total value (GBP) of deemed FIT export payments made to FIT generators and nominated recipients following the submission of valid generation meter readings during that FIT year.
- For levelisation periods from 1 April 2019, total value (GBP) of metered FIT export payments claimed by FIT generators and nominated recipients following the submission of valid export meter readings during that FIT year.
- Total amount (MWh) of electricity deemed to have been exported by FIT generators and nominated recipients following the submission of valid meter readings during that FIT year.

- Total amount (MWh) of metered electricity exported by FIT generators and nominated recipients following the submission of valid meter readings during that FIT year.
- The number of installations that received payments in that FIT year.

9.44. The following components of the annual levelisation report will be determined by the CFR:

- Total number of installations eligible for the qualifying FIT costs in that FIT year.
- Total value of (£) qualifying FIT costs that FIT licensees have incurred in respect of FIT installations during that FIT year.

9.45. FIT licensees will also be required to provide an audit report of the FIT payments they made in that year.

9.46. In addition, all Licensed Electricity Suppliers shall provide Ofgem with details of the total electricity they have supplied in Great Britain for that FIT year and any electricity which is to be exempted from the calculation. The data given for total electricity supplied in Great Britain for that FIT year should be determined using the same methodology as the one used under the RO.<sup>54</sup>

9.47. FIT payments collated for the Annual Levelisation process should be based on payments made ie the FIT generator or nominated recipient has received the respective payment to FIT generators and nominated recipients for the relevant FIT year. This can include payments made to FIT generators after the FIT Year is complete (31 March), up to the date of submitting the Annual Levelisation return, but should only include payments in relation to generation or export during the relevant FIT Year.

9.48. Where payments have been claimed, but not yet received by the generator, the payment should not be included in the Annual Levelisation submission, but instead carried over to the following Annual Levelisation process for reconciliation.

9.49. Where start and end meter readings may cross FIT Years, it will be the responsibility of the FIT licensee to calculate what proportion of the electricity was generated in one FIT year (at a particular tariff rate) and what proportion was generated in the subsequent FIT year (at the particular tariff rate adjusted for inflation).

### Annual Levelisation Schedule

9.50. There are four stages to the levelisation schedule:

---

<sup>54</sup> <https://www.ofgem.gov.uk/ofgem-publications/58129/ro-supplier-guidance.pdf>

- Licensed Electricity Suppliers will be required to send to Ofgem a levelisation report covering a FIT year by 1 August following the end of that FIT Year.
- Ofgem will make the necessary calculation and notify each Licensed Electricity Supplier whether a levelisation payment is owed by them, or due to them.
- Licensed Electricity Suppliers are required to make a levelisation payment following the issue of an annual levelisation payment notification being issued.
- Ofgem will make levelisation payments due to FIT licensees, subject to any shortfall in the levelisation fund, by 1 October following the end of that FIT year.
- For the dates and deadlines of the Levelisation schedule, please refer to the 'Feed-in Tariffs Levelisation Schedule' for the relevant FIT year, on our [website](#).

### Annual levelisation calculations

9.51. Before 1 April 2019: A Licensed Electricity Supplier's annual levelisation payment shall be equal to:

$$alp = \{ms \times [tgp + tdep - (ade \times SSP) + tqc]\} - [igp + idep - (ade \times SSP \times ms) + iqc] - plp$$

9.52. From 1 April 2019: A Licensed Electricity Supplier's annual levelisation payment shall be equal to:

$$alp = \{ms \times [tgp + tdep - (ade \times SSP) + tmep - (ame \times SSP) + tqc]\} - [igp + idep - (ade \times SSP \times ms) + imep - (ime \times SSP) + iqc] - plp$$

- alp - Licensed Electricity Supplier's annual levelisation payment (£)
- ms - Licensed Electricity Supplier's market share
- tgp - total (£) generation payments
- tdep - total (£) deemed export payments
- ade - total (MWh) amount of electricity deemed to have been exported
- SSP - System Sell Price (£/MWh)
- tmep - total (£) metered export payments
- ame - total (MWh) amount of metered exported electricity
- tqc - total (£) qualifying FIT costs
- igp - individual (£) generation payments

- idep - individual (£) deemed export payments
- imep – individual (£) metered export payments
- ime – individual amount (MWh) of metered exported electricity
- iqc - individual (£) qualifying FIT cost
- plp - all of that Licensed Electricity Supplier's periodic levelisation payments in that FIT year (£)

### **Discrepancies**

9.53. If a FIT licensee uncovers any discrepancies or wishes to dispute the levelisation calculations made, they should raise this with the RE compliance team ([recompliance@ofgem.gov.uk](mailto:recompliance@ofgem.gov.uk)) at the earliest possible opportunity, providing the relevant background details.

9.54. Given the tight time frame in which periodic levelisation needs to be reviewed, such discrepancies will not affect the levelisation payments for that periodic levelisation period. Instead, discrepancies will be dealt with during the annual levelisation process.

9.55. However, if discrepancies or disputes concerning the annual levelisation calculation are raised, we will look to resolve those before final invoices are issued.

## 10. Managing Levelisation Fund Shortfalls

### Chapter summary

Details the mutualisation process and the instances in which this process would occur.

### Introduction

10.1. Where a shortfall occurs in the levelisation fund, suppliers who pay into the periodic levelisation fund under the FIT scheme may be required to make additional payments, depending on the size of the shortfall.

10.2. This chapter explains how different levels of shortfalls in the levelisation fund will be managed, including the process of Mutualisation.

### Shortfalls in the Levelisation Fund

#### How Mutualisation is Triggered

10.3. In the event of a supplier being unable to make the whole or part of a periodic levelisation payment as requested by Ofgem, there is likely to be a shortfall in the levelisation fund. As a consequence, payments made from the fund to FIT licensees will be lower than specified. In some cases, this failure to make requested payments may trigger a process known as mutualisation.

10.4. A defaulting licensee<sup>55</sup> may fail to pay an amount that is owed on its due date, causing a shortfall in the levelisation fund. If this amount is not paid within 5 working days of the due date<sup>56</sup> and the total shortfall reaches or exceeds the specified mutualisation trigger range, the process of mutualisation will begin.

10.5. The Secretary of State will determine the mutualisation trigger range each FIT year, at the same time as making the determination of qualifying FIT costs. This will be published by Department for Energy Security and Net Zero on the [www.gov.uk](http://www.gov.uk) website.

10.6. When mutualisation is triggered, suppliers will be required to make additional payments to address the shortfall in the levelisation fund. This is a separate process to levelisation and will take place after payments have been made to FIT licensees out of the levelisation fund (less the shortfall).

---

<sup>55</sup> Article 30A(9) FIT Order

<sup>56</sup> Article 30A(1)(a) FIT Order



10.7. On a case-by-case basis, where a supplier has defaulted on its required levelisation or mutualisation payments, enforcement action may be commenced against them regarding any unpaid amounts, in addition to undertaking all reasonable steps to recover any outstanding payments.

10.8. If a supplier's licence is revoked before we have determined that it is liable to make or receive payment through periodic levelisation, annual levelisation or mutualisation, then that supplier will not be treated as a licensee for the purposes of the levelisation or mutualisation process. If, however, a Licensed Electricity Supplier has its licence revoked after we have determined that a supplier is liable to make a payment in to the periodic or annual levelisation fund, then that supplier will remain subject to that liability. If we have determined that a supplier is entitled to receive a payment from the periodic or annual levelisation fund, that supplier will remain entitled to such part of that payment as the Authority shall determine.

10.9. If a supplier has been issued with a periodic levelisation invoice, makes payment in full, and then that supplier has its license revoked, if mutualisation is then triggered in respect of that period, that supplier will not form part of the mutualisation process .

10.10. If a supplier has been issued with a periodic levelisation invoice, does not make payment (or makes only part payment) on time and mutualisation is triggered in respect of that period, that supplier is not included in mutualisation calculations for that period.

### Calculation of Mutualisation Payments

10.11. In the event of a shortfall in the levelisation fund where mutualisation is triggered, we will notify each supplier that it is liable to make a mutualisation payment through the issue of a 'mutualisation notice'.<sup>57</sup> This notice will be sent 5 working days after periodic levelisation payments have been made by us to FIT licensees. The mutualisation notice will include all details relating to any mutualisation payments due from suppliers, including the deadline for payment.

10.12. The sum specified mutualisation notice is calculated by assessing each supplier's share of the electricity supply market (minus the defaulting licensee), with licensees bearing a share of the total shortfall in proportion to their market share. Existing data provided for the periodic levelisation process will be used for this purpose.

10.13. In most circumstances suppliers will need to make their mutualisation payments to us within 10 working days. However, if the shortfall is greater than the mid-point of the

---

<sup>57</sup> Article 30A (3) Feed-in Tariffs Order 2012 (as amended)

mutualisation trigger, we may extend the mutualisation payment period to 20 working days. The due date for mutualisation payments will always be specified in the mutualisation notice.

10.14. The shortfall will be recovered, up to the upper limit of the mutualisation trigger range, as stated in the determinations made by the Secretary of State.

### Shortfalls in the Levelisation Fund (Mutualisation not Triggered)

#### Shortfalls Below the Mutualisation Trigger Range

10.15. Where a shortfall has occurred in the levelisation fund which is less than the mutualisation trigger range, and therefore insufficient to trigger mutualisation, those FIT licensees which are owed levelisation funds, will be required to absorb the shortfall by receiving reduced levelisation payments.

### Shortfalls in the Levelisation Fund (Mutualisation Triggered)

#### Shortfalls Between the Mutualisation Trigger Range

10.16. Where a shortfall in the levelisation fund causes mutualisation to be triggered, all suppliers who have made payments into the levelisation fund will be required to make additional payments proportionate to their adjusted market share ('mutualisation payments') to make up the shortfall.

10.17. This payment will be in addition to any payments made as part of the levelisation process. Suppliers will be informed by us whether or not mutualisation will take place, prior to the distribution of periodic levelisation payments for that quarter.

#### Shortfalls Above the Mutualisation Trigger Range

10.18. Where a shortfall is greater than the upper end of the mutualisation trigger range, mutualisation will only take place to recover funds up to this limit. Any amount greater than the maximum shortfall will not be recovered through mutualisation.

10.19. Consequently, those FIT licensees which were owed levelisation funds will be required to absorb the additional shortfall by receiving reduced mutualisation distributions.

### Making a Mutualisation payment

10.20. Once a mutualisation notice has been issued, suppliers will be required to make their mutualisation payment to us.

10.21. Payments should be made by electronic transfer to the specified Ofgem mutualisation bank account. We will advise each relevant supplier of the bank account details to be used in the mutualisation notice. Suppliers should ensure the correct payment amount is sent to the correct account as notified by the due date.

### Mutualisation distribution

10.22. Ofgem will redistribute funds raised through mutualisation within 5 days of the specified mutualisation payment deadline. Mutualisation distribution<sup>58</sup> payments will be made by electronic transfer to the bank account nominated by the supplier.

**Figure 7: Mutualisation distribution timescales**

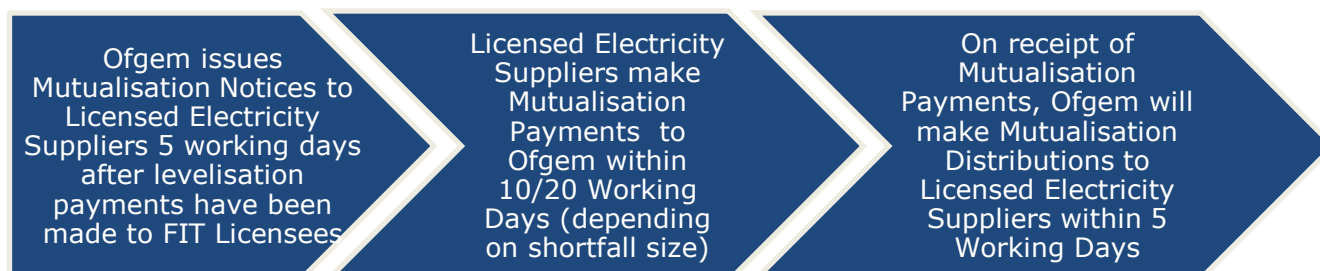

### Late Mutualisation Payments

10.23. Where we receive a late mutualisation payment before mutualisation distributions have been made to FIT licensees, where possible those funds will be included in the mutualisation distribution.

10.24. Where we receive a late mutualisation payment after mutualisation distributions have been made to FIT licensees, those funds will be distributed in accordance with article 30D of the FIT Order.

### Mutualisation: Impact on Levelisation

#### Periodic Levelisation and Mutualisation

10.25. While it is envisaged that levelisation payments will be made to FIT licensees in line with the levelisation schedule as published, we may defer the whole or part of a periodic levelisation payment if a shortfall is identified, until the shortfall has been paid by the defaulting licensee(s) or mutualisation payments have been made.

### Late Payments by Defaulting Licensees

10.26. If we were to receive an unpaid amount from a defaulting licensee, after having already received mutualisation payments from licensees, we will redistribute these funds amongst licensees that made their mutualisation payments within 20 days of receiving them.

---

<sup>58</sup> Article 30A (3) FIT Order

## Annual Levelisation and Mutualisation

10.27. The process of mutualisation will only occur during periodic levelisation. Mutualisation will not occur if there is a shortfall in the Annual Levelisation fund.

10.28. However, mutualisation payments made or received in any given FIT year will be taken into consideration when determining payments required for Annual Levelisation.

# 11. Dispute Resolution

## Chapter summary

Details how to make a complaint and resolve a dispute in relation to the administration of the FIT scheme.

### Disputes Within the FIT scheme

#### Disputes and Complaints between a FIT Generator and a FIT Licensee

11.1. FIT licensees have an obligation to provide a description of the complaints procedure in their statement of FIT terms, and have a duty to participate in the complaints procedure on disputes in relation to compliance with obligations under the FIT scheme.<sup>59</sup> For information on this complaints procedure please consult the Dispute Resolution Process which can be found on the Department for Business, Energy & Industrial Strategy (now the Department for Energy Security and Net Zero) website.<sup>60</sup>

11.2. Complaints against a FIT licensee should be directed towards the FIT licensee in the first instance. If after eight weeks a satisfactory solution has not been agreed between both parties, the complaint may then be referred to the Energy Ombudsman.

11.3. Once the Energy Ombudsman has received a complaint, it will consider whether the FIT licensee has been given sufficient time to deal with the complaint and also assess whether the complaint falls within the remit of the Ombudsman. If the Ombudsman takes on the case, it will investigate and make recommendations to rectify a situation. The FIT licensee then has up to 28 days to action any recommendations by the Energy Ombudsman.

#### Disputes and Complaints Between a FIT Generator and Accreditation Body

11.4. If a FIT generator wants to make a complaint regarding their accreditation under the scheme, it should approach the accreditation body (MCS or Ofgem) to attempt to resolve a dispute.

#### Enquiries, Disputes and Complaints Involving the CFR

11.5. If a FIT generator would like to view the information held on the CFR in relation to them, they should submit a Subject Access Request (SAR) to the Ofgem information request team by

---

<sup>59</sup> Principal Generator Term under clause 6.3.2(a) of the SLCs

<sup>60</sup> [www.gov.uk/government/publications/dispute-resolution-processes-for-feed-in-tariff-complaints](https://www.gov.uk/government/publications/dispute-resolution-processes-for-feed-in-tariff-complaints)

emailing: [CFR.SAR@ofgem.gov.uk](mailto:CFR.SAR@ofgem.gov.uk) Such a request should clearly identify the installation concerned. You will be required to provide documentary proof of identity or other appropriate documentation, as requested by Ofgem, before information can be released.

11.6. If a FIT generator disputes the information contained on the CFR, it should approach its FIT licensee in the first instance. The FIT generator should explain the reasons why they believe the information on the CFR is inaccurate and provide supporting evidence. If the FIT licensee decides that the information contained on the CFR is inaccurate, it should, as soon as is reasonably possible, update the CFR.

11.7. If a FIT licensee considers the information contained on the CFR to be incorrect and cannot amend this, the FIT licensee should contact the CFR team ([FITRegister@ofgem.gov.uk](mailto:FITRegister@ofgem.gov.uk)). The FIT licensee should detail the installation concerned, the incorrect data and what it believes the correct data should be. The FIT licensee should also detail the reasons why it believes the information on the CFR is inaccurate and provide supporting evidence. Ofgem can then take a decision as to what needs amending.

11.8. If a FIT generator or FIT licensee wishes to clarify or dispute any decision taken by Ofgem with regards to the CFR; the FIT generator or FIT licensee should lodge a complaint with Ofgem's CFR team by emailing :[FITRegister@ofgem.gov.uk](mailto:FITRegister@ofgem.gov.uk)The complaint should clearly identifying the installation concerned, the matter needing resolving and provide any relevant evidence.

- If the FIT generator or FIT licensee remains unhappy at how a decision is taken or a mutually agreeable outcome is not reached, it is able to escalate the complaint to [Feedback@Ofgem.gov.uk](mailto:Feedback@Ofgem.gov.uk).
- If the FIT generator or FIT licensee is still not satisfied with the outcome, it can approach the Parliamentary and Health Service Ombudsman who carries out independent investigations into complaints about public bodies.

### Enquiries, Disputes and Complaints Involving Periodic and Annual Levelisation

11.9. If a Licensed Electricity Supplier would like further clarity on the methods used to calculate levelisation payments or annual reconciliation, it should contact the Supplier Compliance team at [RECompliance@Ofgem.gov.uk](mailto:RECompliance@Ofgem.gov.uk). Please note that some information cannot be released if it can facilitate calculation of another supplier's market share or is restricted on other grounds.

11.10. If the Licensed Electricity Supplier believes an error has been made, it should notify the Supplier Compliance team as soon as possible and provide as much detail and supporting evidence as is necessary to outline the error. Ofgem can then take a decision as to whether an error has been made and, if necessary, take corrective action.

### Complaints

11.11. A dispute resolution factsheet has been published by the Department for Business, Energy & Industrial Strategy (now the Department for Energy Security and Net Zero) and this explains the established procedure for complaints and where they should be directed. This document can be found on the Government website<sup>61</sup>.

11.12. If a Licensed Electricity Supplier or FIT generator is unhappy with the way they have been dealt with or the way in which Ofgem has reached a decision, or with how Ofgem operates, they should write to:

Ofgem Complaints  
Operations Hub  
Commonwealth House  
32 Albion Street  
Glasgow  
G1 1LH

Or email: [Feedback@Ofgem.gov.uk](mailto:Feedback@Ofgem.gov.uk)

11.13. A complaint will be acknowledged within two working days. Ofgem will write to the complainant within 20 working days to inform them of the outcome. If it is not possible to get back to the complainant in that time, Ofgem will write to update the complainant on the progress within 20 working days.

11.14. If, after this process, a licensee or FIT generator is still unhappy, they should write to the same address and ask for the complaint to be escalated. The same timescales as above apply to this process.

11.15. If a Licensed Electricity Supplier or FIT generator is still not satisfied, it should take the complaint to the Parliamentary and Health Service Ombudsman who carries out independent investigations into complaints about public bodies. If the complaint is found to be justified, the Ombudsman can recommend that Ofgem provides a remedy.

11.16. Details of how to make a complaint to the Parliamentary Ombudsman can be found on their website at [www.ombudsman.org.uk](http://www.ombudsman.org.uk).

---

<sup>61</sup> [www.gov.uk/government/publications/dispute-resolution-processes-for-feed-in-tariff-complaints](http://www.gov.uk/government/publications/dispute-resolution-processes-for-feed-in-tariff-complaints)

## 12. Appendices

<b>Appendix</b>	<b>Name of Appendix</b>
1	Solar PV Multi-installation Declarations and EER Exemption Template
2	Solar PV Declaration (Change to the FIT Generator or Nominated Recipient)
3	Statement of FIT Terms
4	Best Practice for non-AMR Biennial Meter Verification – Physically Reads (Verification Method One)
5	Best Practice for AMR Biennial Meter Verification – Use of Historical Data (Verification Method Two)
6	Best Practice for AMR Biennial Meter Verification – Audit of System (Verification Method Three)
7	Best Practice for non-AMR Biennial Meter Verification – Generator-Submitted Photographic Evidence (Verification Method Four)
8	Recommended Methodology for Calculating Electricity Supply Data
9	Degression
10	Reporting on deployment caps
11	Metering regulations
12	Continuity of Payments for FIT Generators
13	FIT Licensee Request for Ofgem Investigation
14	Glossary



## Appendix 1 – Solar PV Multi-installation Declarations and EER Exemption Template

### Feed-in Tariffs (FIT) Solar PV Declarations

**All applications for accreditation of new solar PV installations, with an Eligibility Date on or after 1 April 2012, need to be accompanied by a copy of the declarations with the relevant section signed and dated, and if applicable an EER exemption letter. This will then be used by FIT licensees/Ofgem as appropriate to determine whether or not the multi-installation tariff rates should apply and if you are exempt from the EER.**

Tick one of the boxes in relation to the multi installation declarations. Then go on to sign the relevant declarations.

Where a generator claims that the FIT installation is exempt from the Energy Efficiency Requirement, they should submit proof in the form of a written declaration completed by a qualified assessor which confirms that it was not possible to obtain an EPC on the building(s) and to clearly state the reasons why. An example template for this declaration has been provided in this Appendix. Please note that ROOFIT generators will be provided with a slightly different template.

### Multi-installation Declaration

Tick **one** of the following boxes in relation to the multi-installation requirement and sign the relevant declaration overleaf:

- The "FIT Generator"<sup>62</sup> or "Nominated recipient"<sup>63</sup> owns or will receive FIT payments from 25 or more other eligible solar PV installations (complete declaration 1)
- Neither the FIT Generator or nominated recipient owns or will receive FIT payments from 25 or more other eligible solar PV installations (complete declaration 2)

---

<sup>62</sup> "FIT Generator" means in relation to an Accredited FIT Installation, the person identified as the Owner in the Central FIT Register; and in relation to any other Eligible Installation, the Owner,

Whether or not that person is also operating or intending to operate the Eligible Installation;

<sup>63</sup> "Nominated recipient" means a person appointed by a FIT Generator to receive FIT Payments in respect of an Accredited FIT Installation owned by that FIT Generator and recorded as such on the Central FIT Register;

Multi-installation Declarations

**(sign one declaration only from declarations 1-2)**

**Declaration 1**

I \_\_\_\_\_ (“the FIT Generator”) (and<sup>64</sup> I \_\_\_\_\_ (“the Nominated recipient”\*)) certify in respect of this application for accreditation that either the FIT Generator or the Nominated recipient (if there is one) are, or have applied to be, the FIT Generator or Nominated recipient for 25 or more other eligible PV installations located on different Sites.

In this certification, references to the “FIT Generator” and “Nominated recipient” include all persons who are “connected persons”<sup>65</sup> in relation to them.

Signed FIT Generator: \_\_\_\_\_

Signed Nominated recipient\*: \_\_\_\_\_

Dated: \_\_\_\_\_

Please tick the relevant box or boxes to confirm whether the FIT Generator and/or the Nominated recipient owns or will receive FIT payments from 25 or more other eligible solar PV installations:

- FIT Generator
- Nominated recipient\*

\*where applicable

---

<sup>64</sup> Only to be completed where there is a nominated recipient.

<sup>65</sup> A “connected person” in relation to a FIT Generator or a nominated recipient, means any person connected to that person within the meaning of section 1122 of the Corporation Tax Act 2010.

**Declaration 2**

I \_\_\_\_\_ (“the FIT Generator”) (and<sup>66</sup> I \_\_\_\_\_ (“the Nominated recipient”\*)) certify in respect of this application for accreditation that neither the FIT Generator nor the Nominated recipient (if there is one) are, or have applied to be, the FIT Generator or Nominated recipient for 25 or more other eligible PV installations located on different Sites.

In this certification, references to the “FIT Generator” and “Nominated recipient” include all persons who are “connected persons” in relation to them.

Signed FIT Generator: \_\_\_\_\_

Signed Nominated recipient\*: \_\_\_\_\_

Dated: \_\_\_\_\_

\*where applicable

**MCS - EER Exemption Letter Template - To be completed by a qualified assessor or other suitably qualified person.**

I confirm that I assessed the site at the following address

\_\_\_\_\_

on the \_\_\_\_/\_\_\_\_/\_\_\_\_ and determined the building(s) to which the PV installation is wired did not meet the definition of a relevant building at the relevant time for assessing the Energy Efficiency Requirement (EER). The relevant time for applications made on or after 15 January 2016 is the commissioned date. The relevant time for applications made before 15 January 2016 is the eligibility date.

I completed the assessment following the definition of a “relevant building” as defined in the Standard Licence Conditions (SLCs)<sup>67</sup> to be “a roofed construction having walls, for which energy is used to condition the indoor climate, other than such a building for which an Energy

\_\_\_\_\_

<sup>66</sup> Only to be completed where there is a nominated recipient.

<sup>67</sup> Annex 5, paragraph 2.5 of the SLCs; relevant links to the SLCs are provided on the Ofgem website ([www.ofgem.gov.uk/FITs](http://www.ofgem.gov.uk/FITs)) and also on the Department for Energy Security and Net Zero website: (<https://www.gov.uk/government/organisations/department-for-energy-security-and-net-zero>)

Performance Certificate (EPC) cannot be issued; and a reference to a relevant building includes a reference to part of such building which has been designed or altered to be used separately.”

I understand that under the Energy Performance of Buildings (EPB) Regulations, some properties are exempt from the requirement for an EPC. I also understand however, that under FIT Legislation, if a building can be assessed and receive an EPC, then the Energy Efficiency Requirement (EER) will apply (irrespective of whether the EPB exemption applies).

In the space below, please explain why the building(s) is / was not a relevant building at the relevant time for assessing the EER:

I confirm that I am an accredited assessor and provide my credentials:

Accreditation Number: \_\_\_\_\_

Accreditation Scheme: \_\_\_\_\_

**Assessor Name:** \_\_\_\_\_

**Assessor Signature:** \_\_\_\_\_ **Date:** \_\_\_\_/\_\_\_\_/\_\_\_\_

**MCS - EER Exemption Letter Template - To be completed by FIT Generator\***

I declare that the installation sited at the following address \_\_\_\_\_

\_\_\_\_\_

is wired to provide electricity to one or more buildings, and that none of those buildings was a “relevant building” at the relevant time for assessing the Energy Efficiency Requirement (EER). The relevant time for applications made on or after 15 January 2016 is the commissioned date. The relevant time for applications made before 15 January 2016 is the eligibility date.

A relevant building is a roofed construction which has walls *and* where energy is used to condition the indoor climate (whether heating or cooling systems) that can be issued an EPC at the relevant time.

In the space below, please explain why you believe that the building(s) is / was not a relevant building at the relevant time for assessing the EER:

I understand that should this declaration be incorrect, any or all of the entitlement to receive or retain full FIT accreditation for the installation, the tariff date allocated to the installation, and the entitlement to FIT payments in respect of electricity generated by the installation, may be affected.

**FIT Generator Name:** \_\_\_\_\_

**FIT Generator Signature:** \_\_\_\_\_

**Dated** \_\_\_\_\_

\*“FIT Generator” means in relation to an Accredited FIT Installation, the person identified as the Owner in the Central FIT Register; and in relation to any other Eligible Installation, the Owner.

## Appendix 2 – Solar PV Declaration (Change to the FIT Generator or Nominated Recipient)

### Feed-in Tariff (FIT) Solar PV Declaration Change to the FIT Generator or Nominated Recipient

**You must sign one of the enclosed declarations where the FIT Generator or nominated recipient changes.**

Please read the following information to understand which of the declarations are relevant to you.

Tick one of the following boxes then go on to sign the relevant declaration:

- The new "FIT Generator"<sup>68</sup> or "Nominated recipient"<sup>69</sup> owns or will receive FIT payments from 25 or more other eligible solar PV installations (complete declaration 1)
- The new FIT Generator and or the new Nominated recipient does not own or will not receive FIT payments from 25 or more other eligible solar PV installations (complete declaration 2)

#### **NOTE: Sign one declaration only**

#### **Declaration 1**

I \_\_\_\_\_ ("the new FIT Generator") (and<sup>70</sup>/or I \_\_\_\_\_ ("the new Nominated recipient"\*)) certify in respect of this notice of change of identity that the new FIT Generator or the new Nominated recipient (as applicable) is, or has applied to be, the FIT Generator or Nominated recipient for 25 or more other PV Eligible Installations located on different Sites.

Whether or not that person is also operating or intending to operate the Eligible Installation;

<sup>69</sup> "Nominated recipient" means a person appointed by a FIT Generator to receive FIT Payments in respect of an Accredited FIT Installation owned by that FIT Generator and recorded as such on the Central FIT Register;

<sup>70</sup> Only to be completed where there is a nominated recipient

In this certification, references to the "FIT Generator" and "Nominated recipient" include all persons who are "connected persons"<sup>71</sup> in relation to them.

Signed FIT Generator: \_\_\_\_\_

Signed Nominated recipient\*: \_\_\_\_\_

Dated: \_\_\_\_\_

Please tick the relevant box or boxes to confirm whether the FIT Generator and/or the nominated recipient owns or will receive FIT payments from 25 or more other eligible solar PV installations:

FIT Generator

Nominated recipient\*

\*where applicable

**Declaration 2**

I \_\_\_\_\_ ("the new FIT Generator") (and<sup>72</sup>/or I \_\_\_\_\_ ("the new Nominated recipient"\*)) certify in respect of this notice of change of identity that the new FIT Generator or the new Nominated recipient (as applicable) is not, or has not applied to be, the FIT Generator or Nominated recipient for 25 or more other PV Eligible Installations located on different Sites.

In this certification, references to the "FIT Generator" and "Nominated recipient" include all persons who are "connected persons"<sup>73</sup> in relation to them.

Signed FIT Generator: \_\_\_\_\_

Signed Nominated recipient\*: \_\_\_\_\_

Dated: \_\_\_\_\_

\*where applicable

<sup>71</sup> A "connected person" in relation to a FIT Generator or a nominated recipient, means any person connected to that person within the meaning of section 1122 of the Corporation Tax Act 2010.

<sup>72</sup> Only to be completed where there is a nominated recipient

<sup>73</sup> A connected person in relation to a FIT Generator or a nominated recipient, means any person connected to that person within the meaning of section 1122 of the Corporation Tax Act 2010.

## Appendix 3 – Statement of FIT Terms

The content of this appendix is replicated from the Schedule A to Standard Condition 33 of the Electricity Supply Licence. Where the conditions refer to Mandatory FIT licensees, this should be read as Mandatory and Voluntary FIT licensee.

### Statement of FIT Terms

A3.1. The Mandatory FIT licensee shall take all reasonable steps to agree in writing a Statement of FIT Terms with a FIT Generator as regards an Accredited FIT Installation within ten working days of the Confirmation Date, such agreement not to be unreasonably withheld.

A3.2. The Mandatory FIT licensee shall ensure that the Statement of FIT Terms incorporates as a minimum the Principal Generator Terms detailed in Part 1, clause 6.3 and the Principal FIT Licensee Terms detailed in Part 1, clause 6.4, in accordance with any guidance issued by the Authority.

A3.3. The Principal Generator Terms shall include:

- Obligations relevant to FIT Payments, including:
  - Tariff Code
  - Confirmation Date
  - Eligibility Date and Eligibility Period
  - Tariff Date
  - The Generation Tariff applying at the Confirmation Date
  - The Export Tariff applying at the Confirmation Date (where applicable) and how to elect to receive Export Payments
  - Frequency of FIT Payment
  - Data on which calculation of FIT Payments shall be based and the process by which such data is to be provided
  - The consequences of ceasing to be eligible for FIT Payments
  - Any other term that may reasonably be considered to significantly affect the evaluation by the FIT generator of the arrangement under which FIT Payments shall be made by the Mandatory FIT licensee
- Obligations relevant to the protection of the FIT generator to which the Mandatory FIT licensee shall be obliged to adhere, including:



- A description of the Complaints Procedure and a stated duty to participate in the Complaints Procedure on disputes in relation to compliance with obligations under the FIT Scheme
- A duty not to discriminate without objective justification in terms of changing Relevant Electricity Supplier or the prices for supply and other charges as between FIT generators and other parties to whom electricity is supplied by the Mandatory FIT licensee
- A description of the process of Switching and a stated duty to participate as required to facilitate the Switching of a FIT generator
- A duty not to impose any obligations on a FIT generator which are additional to, or more onerous than those that are necessary to enable the Mandatory FIT licensee to meet its obligations under the FIT Scheme
- A duty to fulfil obligations under the FIT Scheme efficiently and expeditiously
- A term setting out the termination rights which permit the FIT generator to withdraw from the FIT Scheme or Switch
- A term identifying the risks to a FIT generator of failure to adhere to the Statement of FIT Terms, for example following failure to provide the required data in a timely fashion and as regards suspension and recoupment of FIT Payments.

#### A3.4. The Principal FIT Licensee Terms shall include:

- A term explaining that FIT Payments shall be made by reference to data in the Central FIT Register;
- A term identifying the FIT generator's obligations as regards providing information, declarations and evidence to the Mandatory FIT licensee and the Authority (as well as any consents required for the purposes of data protection) as required for the administration of the FIT Scheme;
- A term requiring the FIT generator to inform the Mandatory FIT licensee as soon as reasonably possible in the event there is a change in ownership of an Accredited FIT Installation;
- A term requiring the FIT generator to inform the Mandatory FIT licensee as soon as reasonably possible of Extensions or Reductions to an Accredited FIT Installation;
- A term setting out the circumstances and procedures for changing the Nominated Recipient on the Central FIT Register;

- A term explaining meter ownership and responsibilities, including as regards access to the property of the FIT generator if required for inspection, testing and (in the case of the Export Meter) maintenance and if appropriate replacement.

A3.5. In the event the Central FIT Register is amended by the Authority to correct an error or to reflect any change in circumstances relevant to the content of the Statement of FIT Terms, for example, the Extension of an Accredited FIT Installation, the Mandatory FIT licensee shall revise the Statement of FIT Terms as required and an amended version shall be supplied to the FIT generator.

A3.6. The Mandatory FIT licensee shall be required to take due account of guidance issued by the Authority as regards the content and the form of the Statement of FIT Terms but can agree terms more favourable to the FIT generator if so desired;

A3.7. In addition to what is stipulated in the Statement of FIT Terms, the Mandatory FIT licensee shall have the following specific duties as regards FIT generators in the context of the FIT Scheme:

A3.8. When providing information to a FIT generator (whether in writing, by electronic display or orally) in relation to the FIT Scheme, the Mandatory FIT licensee shall take all reasonable steps to ensure it:

- Is complete and accurate
- Is capable of being easily understood by the FIT generator
- Does not mislead the FIT generator, and
- Is otherwise fair, transparent, appropriate and delivered in a professional manner both in terms of content and in terms of how it is presented (with more important information being given appropriate prominence).

A3.9. When making FIT Payments to a FIT generator or Nominated Recipient, the Mandatory FIT licensee shall ensure that the Statement of FIT Terms by reference to which it does so does not materially discriminate without objective justification between one group of FIT generators and any other such group.

A3.10. The Mandatory FIT licensee shall notify FIT generators and Nominated Recipients to which it makes FIT Payments as soon as reasonably possible at the occurrence of an Insolvency Event.

A3.11. To the extent a FIT generator falls into the definition of Customer, Domestic Customer or Micro-Business Consumer under the Electricity Supply Licence, participation in the FIT

Scheme and involvement in Small-scale Low-carbon Generation shall have no effect on the rights and obligations resulting from that status under Sections A and B of the Electricity Supply Licence.

## Appendix 4 – Best Practice for non-AMR Biennial Meter Verification – Physically Reads (Verification Method One)

A4.1. FIT licensees' obligations include taking all reasonable attempts to verify generation and/or export meter readings once every two years. This provides extra assurance on eligible output before making FIT payments. Where FIT licensees are fulfilling this obligation by physically reading meters, they should consider the following areas of best practice:

### Visits to sites

A4.2. FIT licensees should attempt to access a site several times before taking further action. The number of visits may vary between different sites, but FIT licensees must assess if all reasonable attempts have been made. FIT licensees should consider the cost benefit of arranging specific visits rather than turning up unannounced.

### Time of visits

A4.3. Visits to sites should be varied and attempts should be made in the morning, afternoon, and evening to increase the opportunity for FIT generators to be available and on site. Licensees should make at least three visits.

### Leave cards

A4.4. It is considered best practice to leave a card behind after each failed attempt to access the site. The wording of the card can vary, but should include the following information:

- A clear statement that the visit relates to FITs (and not other meter reads)
- Contact details for the FIT licensee and the Meter Reader;
- A reminder of the requirements under FIT Terms and Conditions; and
- Potential action a FIT licensee may have to take (ie suspension of payments) if access is not granted.

### Pre-arranged visits

A4.5. FIT licensees should try to arrange a specific time to visit the site with the FIT generator. If the generator fails to allow access after such a request, the Licensee should consider payments being withheld. The FIT licensee should inform the FIT generator of the payments status and set out their obligations to contact the FIT licensee to arrange further visits.

### ROO-FIT (over 50kW DNC PV/Wind and all AD/Hydro installations)

A4.6. It is considered best practice to pre-arrange visits to larger sites as access to the site will often be restricted and may be remote.

### Communication

A4.7. FIT licensees should make FIT generators aware of the requirement for physical meter readings at the time of registration. It is considered best practice to also add reminders to ongoing correspondence with FIT generators.

### Contractual Arrangements

A4.8. FIT licensees should ensure contractual arrangements in relation to meter readings are fit for purpose to meet their obligations.

### Notification to Ofgem of withholding of payments

A4.9. FIT licensees should notify us of all installations which they wish to be placed under investigation and have payments withheld because meter verifications have not been completed. They should provide this information to us on or before the last day of the first month of each quarter. It is the FIT licensee's responsibility to ensure the verification takes place before the two-year point.

## Appendix 5 – Best Practice for AMR Biennial Meter Verification – Use of Historical Data (Verification Method Two)

A5.1. FIT licensees' obligations include taking all reasonable attempts to verify generation and/or export meter readings once every two years. This provides extra assurance on eligible output before making FIT payments. Where FIT licensees are fulfilling this obligation by comparing historical data, they should have consideration of the following areas of best practice.

### Preparing for verification

A5.2. Before a FIT licensee can verify meter readings they should have a process that allows them to view the historical data relating to each meter they are verifying. In order to facilitate this, the FIT licensee should request the FIT generator has in place such agreements between the relevant parties.

A5.3. When a FIT generator notifies their FIT licensee they have AMRs installed on their installations, it is recommended that the two parties agree a method for allowing the FIT licensee to access the data directly. Options for how this may be achieved include the following but others are also available.

- The FIT licensee has the ability to log-in to the back-office (Head-end) system (HES) to view historical, raw (uncorrected) data. This can be used where the meter readings are handled either by a third party or 'in-house'
- Where it is not possible to gain direct access to historical data, the FIT generator may submit it. The FIT licensee should ensure there are sufficient governance procedures in place to ensure that the data submitted is the raw data. This may include a signed declaration from the FIT generator around the integrity of the data.

### Conducting the verification

A5.4. It is essential that the FIT licensee has access to raw data and not an accumulation of corrected meter readings. We expect that the FIT licensee will be able to see the half-hourly data from the AMR rather than the cumulative amount submitted periodically by the FIT generator.

A5.5. Once the FIT licensee has the raw data they should arrive at their own cumulative amount and compare this to the amounts submitted by the FIT generator. We expect the two amounts to be within 1% of each other if the FIT generator has been submitting accurate meter readings.

A5.6. FIT licensees may use their discretion if the FIT generator can provide sufficient evidence for a difference in amounts. Examples include, but are not limited to, reconciled meter readings or additional data becoming available.

### Notification to Ofgem of withholding of payments

A5.7. FIT licensees should notify us of all installations which they wish to be placed under investigation and have payments withheld because meter verifications have not been completed. They should provide this information to us on or before the last day of the first month of each quarter. It is the FIT licensee's responsibility to ensure the verification takes place before the two-year point.

## Appendix 6 – Best Practice for AMR Biennial Meter

### Verification – Audit of System (Verification Method Three)

A6.1. FIT licensees' obligations include taking all reasonable attempts to verify generation and/or export meter readings once every two years. This provides extra assurance on eligible output before making FIT payments. Where FIT licensees are fulfilling this obligation by auditing an AMR's systems, they should have consideration of the following areas of best practice.

#### Preparing for verification

A6.2. To provide assurance that the generator's system is still meeting the required standards, the licensee may, if appropriate complete an audit of the generator's AMRs at least once every two years. This method of verification works on the basis that the licensee accepts that AMR submitted meter readings are correct.

A6.3. Where possible, the auditing of AMR systems should be undertaken by someone not directly connected to the billing or approval process for the installations in question. The FIT licensee should provide a full explanation if such an arrangement is not possible.

A6.4. The FIT licensee should call for the evidence that will be required to complete the audit early enough to ensure they can conduct the verification by the two-year deadline. The FIT licensee may also wish to use this audit format scope when considering whether or not an AMR is an AMR

#### Scope for auditing of AMR systems

A6.5. When using this method for verification, the FIT licensee must include the following criteria in the scope of the audit:

- There should have been no change to the material state of the AMR or the installation as a whole over the verification period without the FIT licensee being informed at the time.
- No more than 25% of readings submitted over the verification period should have fallen outside of the relevant tolerance limits. This equates to two out of eight quarterly submissions.
- The only electricity flowing through the AMR should be generated by the eligible FIT installation and any FIT accredited extensions to the installation as shown on the Central FIT Register.
- The asset register used to tie the AMR's SIM card (or alternative) to the meter serial number should not have changed. The FIT generator will need to explain why any changes



have happened and provide records to show that the change in SIM Card did not affect the integrity of data.

- There is a four-level security password in place as a minimum. A record should be kept of people with password access at each level
- The primary means of communication on the AMR should still be functioning accurately. If the AMR has a secondary means of communication, it should still be functioning correctly. The means of communicating data should be in accordance with this guidance.
- Where the AMR data is not handled by a third party service provider, there should be adequate measures in place to confirm the integrity of the AMR data.
- The AMR has been installed by an accredited installer to the appropriate industry standards.
- The manufacturer has not issued any recall notices or modifications during the verification period. If they have, the FIT licensee should have been informed at the time.
- The AMR is either a composite sealed unit or it should have appropriate physical security seals in place. (This is not mandatory but is best practice).

A6.6. FIT licensees should notify us of all installations which they wish to be placed under investigation and have payments withheld because meter verifications have not been completed. They should provide this information to us on or before the last day of the first month of each quarter. It is the FIT licensee's responsibility to ensure the verification takes place before the two-year point.

## Appendix 7 – Best Practice for non-AMR Biennial Meter Verification – Generator-Submitted Photographic Evidence (Verification Method Four)

A7.1. FIT Licensees' obligations include taking all reasonable steps to verify generation and/or export meter readings once every two years. This provides extra assurance on eligible output before making FIT payments. Where FIT Licensees are fulfilling this obligation with generator-submitted photographic evidence, they should have consideration of the following areas of best practice.

### The photograph

A7.2. The photograph must be submitted electronically.

A7.3. The photograph must clearly show the meter reading on the meter display.

A7.4. The photograph should include the serial number of the meter. Where it is not possible to include the serial number in the same photograph as the meter reading, the generator should submit a separate video alongside the photograph which clearly shows both the meter reading and the serial number in a single unedited shot. If it is not possible to photograph the meter serial number at all (eg because it is obscured by a wall), then photographs should be submitted of the meter on all sides showing that it is not possible to view the meter serial number.

A7.5. The FIT Licensee must retain the photographic evidence and produce it to Ofgem and/or Ofgem's appointed auditors on request.

A7.6. If there is any doubt about the authenticity of a submitted photograph then it should not be accepted. If the licensee believes that the photograph may have been edited to alter the meter reading, then they should contact our counter-fraud team at [counterfraud@ofgem.gov.uk](mailto:counterfraud@ofgem.gov.uk) for further guidance.

### When to not use photographic evidence

A7.7. Where a FIT Licensee believes that there is a significant risk of fraud occurring in regards to a specific installation, the Licensee should undertake the biennial meter verification using physical meter reads rather than photographic evidence, even if photographic evidence could otherwise have been used.

A7.8. Licensees should also verify meters using a method other than photographic evidence where it would be dangerous or unsafe for the generator to take a photograph of the meter readings, such as where the meters are located in an unboarded loft space, or where a generator does not wish to do so.

A7.9. We also expect Licensees to provide advice and assistance to generators in taking and submitting the required photographs where necessary. This assistance may include the production of guidance documents for generators on how to photograph their meters, how to identify the meter serial number, and so on.

### Notification to Ofgem of withholding of payments

A7.10. FIT Licensees should notify us of all installations which they wish to be placed under investigation and have payments withheld because meter verifications have not been completed. They should provide this information to us on or before the last day of the month at [RECompliance@ofgem.gov.uk](mailto:RECompliance@ofgem.gov.uk), in line with our Biennial Meter Verification process. It is the FIT Licensee's responsibility to ensure the verification takes place within the two year timeframe set out in the Standard Conditions of Electricity Supply Licence.

A7.11. Our proposals for photographic evidence are, along with the rest of the guidance, intended to enable FIT Licensees to take all reasonable steps actively to reduce error and combat abuse of the scheme. As such, Licensees are obligated to take account of guidance.

## Appendix 8 – Recommended Methodology for Calculating Electricity Supply Data

### Introduction

A8.1. Suppliers are required to calculate and submit the total electricity supplied by each licence under the Levelisation processes of the Feed-in Tariffs scheme. This appendix summarises the requirements for calculating the supply data to be reported for both FIT periodic and annual Levelisation processes. The appendix also contains guidance on which data flows should be used and the timing of when each calculation should occur to enable consistency of the supply data across both Feed-in Tariffs and Renewable Obligation schemes.

### Levelisation submissions

A8.2. Suppliers are required to report supply data to Ofgem by 1 August each year for the Annual Levelisation reconciliation process, in addition to quarterly submissions 8 working days after the end of each quarter. In order to maintain a consistent basis of measurement amongst suppliers, ELEXON settlement data is considered the standard for settlements data across the industry which provides a consistent basis on which all suppliers can report. We recommend that all submissions should be based on ELEXON data as detailed in this Appendix.

A8.3. For all non-half hourly customers, the ELEXON dataflow D0030 Non Half Hourly DUoS Report (summation of Daily Profiled SPM Total Annualised Advance and Daily Profiled SPM Total EAC in Group TOT) should be used for reporting supply data. Alternatively, D0296 Supplier BM Unit Report (summation of Daily Aggregated BM Unit Energy in Group TL1 for Consumption Component Classes 17-19 in Group CCC, ie Active Import for Measurement Quantity id AI for Data Aggregation Type N) should be used. These flows contain the volumes which have been delivered to customers and therefore no adjustments to line losses need to be made in respect to reporting supply for the Feed-in Tariffs.

A8.4. For all half hourly customers, the ELEXON dataflow D0296 Supplier BM Unit Report (summation of Daily Aggregated BM Unit Energy in Group TL1 for Consumption Component Classes 1, 2, 9, 10, 23, 28, 42, 45, 54 and 57 in Group CCC, ie Active Import for Measurement Quantity id AI for Data Aggregation Type H) should be used for reporting supply data. Alternatively, other dataflow containing equivalent information (for example, D0040/D0298 Aggregated Half Hour Data File or D0036/D0275 Validated Half Hourly Advances, although these latter two contain data at MPAN level rather than summarised to Consumption Component Class) should be used. These flows contain the volumes which have been delivered to customers and therefore no line loss factors need to be applied in respect of this supply data.

A8.5. For all embedded directly connected supply, the Elexon dataflow CDCA-i012 (also known as C0121) "Report Raw Meter Data" should be used for reporting supply data. Only embedded connected import should be included (ie all Main Active Import channels should be used) for BM Unit IDs prefixed with 'E' for those embedded units meeting the definition of supply in paragraph 5.2 above.

A8.6. For all transmission connected customers, the Elexon dataflow SAA-i014 (also known as S0141) "Settlement Reports" should be used for reporting supply data. Only transmission connected import should be included (ie BM Unit Metered Volume (QM) for negative (off taking) for BM Unit IDs prefixed with 'T' and selected BM Unit IDs prefixed with 'M'36).

A8.7. We recommend that all submissions of EII excluded electricity should be based on EMR Settlement (EMRS) data.

A8.8. For all suppliers who supply electricity to a certified EII with meters registered in the Supplier Meter Registration Service (SMRS), typically used for distribution-connected sites, the Elexon dataflow D0354 EMR Reporting Notification should be sent from the supplier to the Half Hourly Data Aggregator (HHDA). If the EMR Reporting Notification is valid, the HHDA will confirm to the supplier that it will submit metered data to EMRS via the D0355 dataflow. The supplier should then send the D0355 information in an email to [contact@emrsettlement.co.uk](mailto:contact@emrsettlement.co.uk).<sup>74</sup>

A8.9. Suppliers who supply electricity to a certified EII with meters registered in the Central Meter Registration Service (CMRS), typically used for transmission-connected sites, do not need to notify EMRS that they have a customer with an EII certificate. However, they may be contacted by EMRS to discuss the metering set-up.

A8.10. For reporting under the quarterly FIT **Periodic Levelisation** processes, data is required to be submitted to Ofgem after the end of each quarter, covering electricity supplied during that quarter. Data submitted for the Periodic Levelisation process should be made via the Renewable and CHP Register/Central FIT Register system.

A8.11. Based on the assumption of extracting the data at the end of each quarter, **R1** settlement data should be used in the first instance. Where R1 data is not available, **SF** settlement data should be used. In instances in which neither data is yet available supply data can be estimated.

---

<sup>74</sup> For further information, see [https://www.elexon.co.uk/wp-content/uploads/2016/08/HHDA\\_Metering\\_EMRS\\_FAQs\\_v4.0.pdf](https://www.elexon.co.uk/wp-content/uploads/2016/08/HHDA_Metering_EMRS_FAQs_v4.0.pdf)

A8.12. For reporting under the **Annual Levelisation** process, supply data for the previous FIT year (1 April -31 March) must be submitted to us by **1 August**. There are similarities between the requirements for the Feed-in Tariffs and Renewables Obligation schemes (which have a deadline of 1 July) in terms of the supply data to be submitted. We recommend that the data calculated and submitted under the RO is submitted for the Feed-in Tariffs Annual Levelisation process just one month later. This should reduce the burden on suppliers, and ensure duplication is kept to the minimum.

A8.13. We would expect that any adjustments to the supply data (eg removal of Northern Ireland and Isle of Man data), are reflected on both the RO and FIT submissions, following the criteria set out in the RO Guidance.

A8.14. Where RO data is used for the FIT Levelisation process, any supply for Northern Ireland or the Isle of Man, should be removed from the data submitted. The FIT data should only reflect supply to customers within Great Britain.

A8.15. It is recognised that there may be other adjustments which suppliers feel are necessary to make to the supply volumes computed from ELEXON data flows above. These may relate to specific customer sites and EACs<sup>75</sup> which it is aware have been settled by ELEXON using incorrect or unrealistic values. For suppliers with smart metered customers, it may be the case that the actual consumption indicated by data received from smart meters indicates consumption either higher or lower than ELEXON data suggests and any adjustment made in respect of this data should include supporting calculations. Any other adjustments which are made to data that the supplier believes need to be made (eg private wire connections) should be transparent and substantiated in the reporting, with a clear reconciliation between supply volumes thus calculated and supply volumes reported on relevant settlement reports.

A8.16. Suppliers which have customers on sale and buy back contracts or customers connected directly to the transmission system must include supply under these contracts in the reporting figures provided to Ofgem in respect of the Feed-in Tariffs. For those suppliers who have a White Label provider<sup>76</sup>, the supply made under the White Label agreement must be included in the supply figures reported for the supplier.

A8.17. Suppliers should provide an overall reconciliation of supply volumes reported by 1 August to those previously reported each quarter for the Periodic Levelisation process, with an

---

<sup>75</sup> Estimated annual consumption.

<sup>76</sup> A 'White Label' supply provider is an existing company (usually with an established brand name) that markets the supply of electricity through and on behalf of a licensed supplier.

explanation of any significant movements. It is recognised that there are likely to be movements in respect of supply reported using data from later settlement runs.

A8.18. Any deviations from the requirements set out above should be confirmed with Ofgem prior to submission of supply data.

## Appendix 9 – Degression

### Default Degression Mechanism

A9.1. A default degression mechanism, as described in the SLCs, runs between 8 February 2016 and 31 March 2019 for PV, wind and hydro installations and between 1 April 2017 and 31 March 2019 for AD installations. Generation tariffs change on the first day of each quarter for new installations that apply on or after 15 January 2016. Contingent degression occurs if a deployment cap is reached. These tariffs are also subject to adjustment at the end of each FITs year to reflect the RPI change. Further information on contingent degression is provided after this section.

A9.2. The initial tariff rates for each tariff period associated with the default degression mechanism, are available in the Licence Conditions<sup>77</sup>. We will publish updated tariff tables within 5 working days of the start of each tariff period on our website<sup>78</sup>.

### Contingent Degression Mechanism

A9.3. If a deployment cap is reached, this will result in a 10% degression of the tariff rate that applies to the next tariff period, and all subsequent tariff periods for that specific cap. As an example, if the <10kW band reaches in Q1 2016, then:

- The Q2 2016 tariff will degress by 10% from 4.32 to 3.89,
- The Q3 tariff will degress by 10% from 4.25 to 3.82,
- This will continue until Q1 2019.

A9.4. Within five working days of the start of each tariff period we will publish updated tariff rates on our website.

A9.5. Micro CHP installations are subject to contingent degression from 1 April 2017.

---

<sup>77</sup> For the latest version of the Licence Conditions, follow this link: <https://www.ofgem.gov.uk/licences-codes-and-standards/licences/licence-conditions>, and under the 'Electricity' heading, click 'Electricity Supply Standard Licence Conditions'.

<sup>78</sup> <https://www.ofgem.gov.uk/environmental-programmes/feed-tariff-fit-scheme/feed-tariff-fit-reports-and-statistics>



## Appendix 10 – Reporting on deployment caps

A10.1. This appendix explains how we monitor deployment caps and report on deployment.

### How we monitor deployment caps

A10.2. Ofgem monitors MCS and ROO-FIT deployment using data from the MCS database and ROO-FIT applications. Deployment caps are filled in date and time order according to an applicant's ROO-FIT application date and time, or an installation's MCS issue date and time. The data is refreshed daily until a tariff period is closed or a cap is reached.

A10.3. As soon as a deployment cap has been reached we will freeze the deployment data for that cap. No alterations will be made to the data. Where an application is submitted after a cap has been reached but before the tariff period ends, we will continue to process these applications and will provide an indication of which tariff period they are queued for entry into. This will be an indication only, as if applications for installations that are ahead in the queue are cancelled, the installation may fall into an earlier tariff period. We will confirm the tariff period the installation has gained entry into once the relevant tariff period has opened.

A10.4. There are no more deployment caps after 31 March 2019. If the final cap is closed, then no more applications of that type can be accredited as part of the scheme.

### Cancelled and refused ROO-FIT applications

A10.5. ROO-FIT applications that are cancelled before a tariff period is closed or before a cap is reached are discounted from the cap and space in the cap is available to later applicants. ROO-FIT applications that were counted towards a cap and are cancelled after a tariff period is closed or after a cap is reached will be counted towards that cap. See information on 'Recycling un-used capacity' at the end of this appendix.

### MCS certificate versions

A10.6. Where more than one MCS certificate exists for an installation, it is the issue date and time of the first certificate that will count towards the cap.

## Reporting

### Deployment statistics

A10.7. We publish regular reports on our website<sup>79</sup> showing deployment against the caps for the tariff period that is open.

---

<sup>79</sup> Reports are available here: <https://www.ofgem.gov.uk/environmental-programmes/feed-tariff-fit-scheme/feed-tariff-reports-and-statistics/feed-tariff-deployment-caps-reports>

A10.8. We also publish indicative information on the capacity and number of installations which are queued for entry into future tariff periods. This is indicative only, because the deployment data for these installations will be refreshed when the new tariff period opens. This refresh of the data means that any applications cancelled prior to the new tariff period opening will be removed from the queue and space in the new tariff period will be available to later applicants.

### When a deployment cap is reached

A10.9. We publish when caps are reached on our website as soon as possible after a cap has been reached. We also publish updated information on all deployment caps at the same time. No further installations in the tariff band that has been reached are then eligible for the tariff rate that applies in that period and a contingent degression of 10% will be applied to the tariff rate in the next and all subsequent tariff periods for that tariff band. New tariffs are published within five days of the start of each tariff period.

A10.10. Figure 2 lists our reporting timelines.

### Recycling of un-used capacity

A10.11. When a tariff period is closed, any un-used capacity will be added to the corresponding cap in the next tariff period.

**Figure 2: Reporting timelines**

Regular reporting	When a tariff period opens	When a cap is breached
<ul style="list-style-type: none"> <li>Deployment towards each cap is published weekly for the first month of deployment caps. We will then reassess the frequency of reporting based on deployment.</li> </ul>	<ul style="list-style-type: none"> <li>Tariff rates will be published within five working days of the start of each tariff period.</li> </ul>	<ul style="list-style-type: none"> <li>The cap that has been reached will be published on our website.</li> </ul>
<ul style="list-style-type: none"> <li>An indicative queue (ie capacity and number of installations) for future tariff periods is published regularly.</li> </ul>	<ul style="list-style-type: none"> <li>Deployment statistics for the previous tariff period will be published within the five working days of the start of the next tariff period.</li> </ul>	<ul style="list-style-type: none"> <li>A tweet will be published shortly after the cap is reached.</li> </ul>
	<ul style="list-style-type: none"> <li>Deployment caps for the current tariff period will be adjusted if there is un-used capacity in the previous tariff period and the adjusted deployment caps published.</li> </ul>	<ul style="list-style-type: none"> <li>Deployment statistics for each cap in the current tariff period are updated and published on our website.</li> </ul>

	<ul style="list-style-type: none"><li>• Applicants that have been in the queue for this tariff will be emailed to confirm whether they have fallen into the open tariff period.</li></ul>	<ul style="list-style-type: none"><li>• An indicative queue (ie capacity and number of installations) for future tariff periods is published.</li></ul>
--	---	---

## Appendix 11 – Metering Regulations

A11.1. All meters used in the FIT scheme must comply with the relevant metering legislation. These include:

- Schedule 7 to the Electricity Act 1989;
- The Meters (Approval of Pattern or Construction and Manner of Installation) Regulations 1998, (S.I. 1998/1565);
- The Meters (Certification) Regulations 1998 (S.I. 1998/1566);
- The Electricity (Approval of Pattern or Construction and Installation and Certification) (Amendment) Regulations 2002 (S.I. 2002/3129);
- The Measuring Instruments (EC Requirements) (Electrical Energy Meters) Regulations 1995 (S.I. 1995/2607);
- The Measuring Instruments (EC Requirements) (Electrical Energy Meters) (Amendment) Regulations 2002 (S.I. 2002/3082);
- The Measuring Instruments (Active Electrical Energy Meters) Regulations 2006 (S.I. 2006/1679)

## Appendix 12 – Continuity of Payments for FIT Generators

A12.1. This Appendix aims to set out the actions that will be taken in the event of a license revocation or insolvency event.

### Background

A12.2. There are two processes in the event of a failure of a FIT licensee and/or an electricity supplier. The Continuity of FIT Payments Direction (CoFPD) process is designed to ensure that FITs payments for accredited FIT installations continue after the failure of a FIT licensee. Where a supplier of gas or electricity fails, the Supplier of Last Resort (SoLR) process ensures continuity of supply following the failure. In some cases, where an electricity supplier, which is also a FIT licensee fails then both SoLR and CoFPD processes will run.

A12.3. Further information on the SoLR process can be found in our 'Supplier of Last Resort: Revised Guidance'<sup>80</sup> document, available on the Ofgem website.

### Continuity of FIT Payments Direction

A12.4. A Continuity of FIT Payments Direction (CoFPD) may be issued if a Voluntary or Mandatory FIT licensee's electricity supply licence is revoked, or if such a licensee becomes insolvent. The CoFPD is intended to ensure that payments due to FIT generators are not affected by the failure of their FIT licensee. A CoFPD will usually include payments which were previously missed by the failed licensee and never made or not made in full, provided the generator was entitled to receive these FIT payments immediately before the licence revocation or insolvency event. If a generator elects to switch to another FIT licensee before that FIT licensee's licence is revoked or they become insolvent, the generator will also usually receive protection under the CoFPD, provided that the generator was immediately entitled to receive FIT payments from the failed licensee at the point of licence revocation or insolvency. In addition, some protection is also provided to applicants to the FIT scheme with MCS-certified installations which are yet to be accredited.

A12.5. The CoFPD is intended to ensure FIT generators are not adversely affected by the failure of their FIT licensee with regard to their FIT payments. It provides assurance that electricity generated by an accredited FIT installation between the date of the last meter reading, where FIT payments were made, and the date the accredited FIT installation moves to a new FIT licensee, will be paid. Interest is not provided for under the FIT Order. CoFPD can also cover previously missed payments for which the failed licensee was responsible, where appropriate and as set out by Ofgem in any CoFPD issued.

---

<sup>80</sup> <https://www.ofgem.gov.uk/publications-and-updates/supplier-last-resort-revised-guidance-2016>

A12.6. It is for the licensee to satisfy themselves that any missing payments are evidenced appropriately before payment is made. For the avoidance of doubt, FIT payments made in line with a CoFPD issued by Ofgem can be included in the levelisation process.

A12.7. If the failed electricity supplier is not a FIT licensee, no accredited FIT installations will be affected. At the time of the failure, we will assess if, and how much, the Supplier owed into the levelisation fund. The failure of a Supplier may also cause a shortfall in the Levelisation Fund, which could lead to Mutualisation being triggered ([see Chapter nine](#)).

**Notification of a CoFPD event**

A12.8. We will notify all FIT licensees that a CoFPD has been issued as soon as possible after the event. The notification will state the matters to be taken into account by FIT licensees in determining the date on which affected FIT generators transfer to them. Further support on transferring installations from the failed licensee to a new one will be provided by Ofgem’s Central FIT Register team.

A12.9. It is the affected FIT generator’s responsibility to select and agree FIT Terms with a new FIT licensee.

**Figure 2. Flow chart of outcomes of failure events by electricity supplier FIT status**

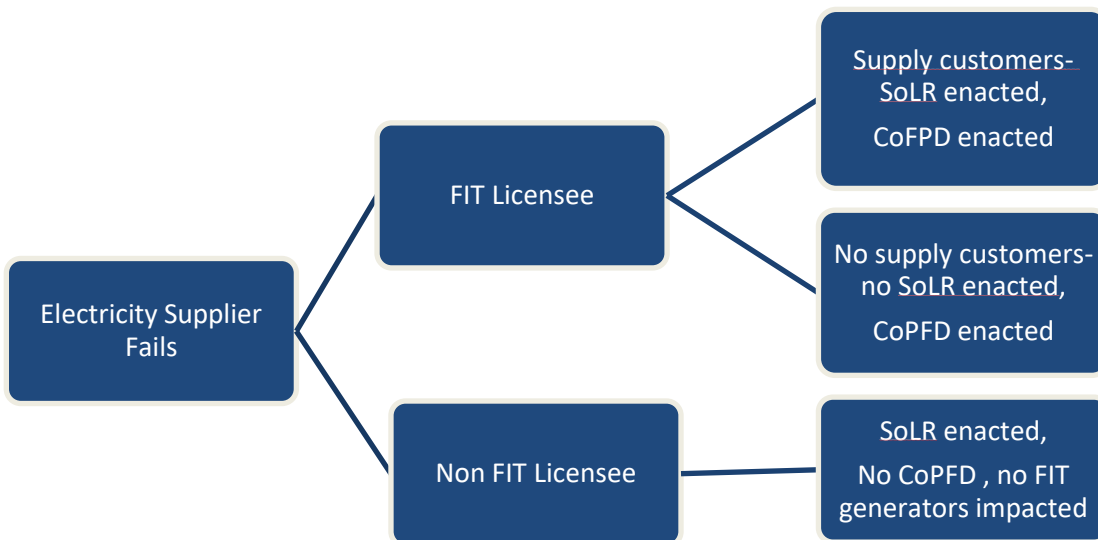

**Data Regarding FIT Installations**

A12.10. Prior to licence revocation or insolvency we will, where possible, request from the FIT licensee information concerning the most recent paid meter readings associated with the accredited FIT installations registered with them. This may include (but is not limited to):

- Latest and some historical meter reads and dates taken;

- Last paid meter reading and date that read was taken; and
- Payment information including amounts and dates.

A12.11. A list of any outstanding written requests received for MCS-certified installations that have not yet been entered onto the CFR will also be requested. If this information is received it may be made available to the SoLR or other FIT licensees requiring clarification.

### Informing Customers and FIT Generators

A12.12. In the event of a SoLR being appointed, the new supplier will contact all its new customers and as part of this communication it is required to advise them of its FIT Status.<sup>81</sup> If the SoLR is a non-FIT licensee, they will be required to inform customers of how to contact a FIT licensee.

A12.13. In the event that no SoLR is appointed, or where there are significant numbers of affected FIT generators who are not supply customers, we will contact those affected FIT generators, most likely through a publication on our website. We will also keep records of all affected FIT generators and their transfer to other FIT licensees.

### Requests from FIT Generators

A12.14. It is the responsibility of the FIT generator to contact a FIT licensee of their choice and request FIT payments. The affected FIT generator is free to request FIT payments from any FIT licensee. A list of FIT licensees can be found on the Ofgem website<sup>82</sup>.

A12.15. When approached by an affected FIT generator, a Mandatory FIT licensee is obliged to make FIT payments for electricity generated or exported by the Accredited FIT Installation.

A12.16. When approached by an affected FIT generator, a Voluntary FIT licensee may elect to make FIT payments for electricity generated or exported by the Accredited FIT Installation (unless they are the import supplier, the installation's TIC is 50kW or less and the FIT generator is also an import customer of the FIT licensee, in which case the FIT licensee is obliged to make FIT payments for electricity generated or exported by the Accredited FIT Installation).

A12.17. The FIT generator will provide their new FIT licensee with all the information they possess regarding their installation. This will include name, address, FIT ID, MCS/ROO-FIT

---

<sup>81</sup> Refer to Condition 21C of the Standard Conditions of Electricity Supply Licence

<sup>82</sup> <https://www.ofgem.gov.uk/environmental-programmes/feed-tariff-fit-scheme/applying-feed-tariff/registered-fit-licensed-suppliers>

number, technology and capacity as well as billing information and the date of the meter reading when the last FIT payments were made.

### Transfer Process

A12.18. Once a CoFPD is issued, the failed FIT licensee's access to the CFR will be disabled. Therefore, the FIT licensee will not be able to complete the switching process which governs the move of accredited FIT installations between FIT licensees.

A12.19. If a FIT licensee has any outstanding switch requests with the failed FIT licensee, these will not be completed. Switches to and from the failed FIT licensee will be void.

### Transferring FIT installations

A12.20. On deciding to accept an installation the FIT licensee will need to contact the CFR Team on [FITRegister@ofgem.gov.uk](mailto:FITRegister@ofgem.gov.uk) to request the transfer of the installation in the CFR. With the CoFPD announcement, FIT licensees will usually receive further guidance with IT procedures and templates. Please see Figure 3 below for a summary of the process. On receipt of a transfer request under a CoFPD, we will confirm whether the FIT ID is an affected installation to the potential FIT licensee.

**Figure 3. Summary of high level process post CoFPD**



A12.21. Depending on the number of affected installations, it may be necessary to process transfer requests in batches. If the FIT licensee has multiple transfer requests it should use the template that we will provide if required. Transfers should occur within 15 working days (as appropriate and within receipt of accurate information).

A12.22. The FIT licensee will receive notification confirming that accredited FIT installations have been transferred to it. Following the transfer, it will be necessary for the FIT licensee to enter the date upon which the Statement of FIT Terms were agreed before payments can begin.

A12.23. Once the transfer is complete we will provide the last paid meter reading details of relevant FIT installations, so long as the information has been communicated by the failed FIT licensee. If there are doubts as to the validity or completeness of the data, the new FIT licensee should consult the meter readings and payment evidence provided by the FIT generators.



A12.24. The transfer date must be determined by the FIT licensee on the basis of instructions specified in a CoFPD. This will generally be from the date of the meter reading when the last FIT payments were made from the failed FIT licensee in relation to the affected accredited FIT Installation.

### Informing New Customers of a Licensee's FIT Status and Retention of Data

A12.25. Standard Licence Condition Article 21C requires that all new supply customers are informed of the licensee's FIT status. Also, SLC 33, Article 5.3 requires the retention in a portable form of data/information relating to FITs installations, and the provision of such data to the Authority when requested under an Information Request.

A12.26. There is no prescribed structure for the storage or supply to Ofgem of historic meter reading/payments data. However, this data should be provided in spreadsheet format with payments, meter readings and relevant dates included and clearly assigned to a specific FIT ID.

A12.27. In order to assist any future transfer process brought about by a FIT licensee failure, amendments have been made to Article 6 (Statement of FIT Terms) of Part 1 of Schedule A to Standard Condition 33. This will require that FIT generators keep details of meter readings taken for 1 year, commencing with the date on which a meter reading is taken by or supplied to a FIT licensee. Further, FIT generators are required to keep details of FIT payments received by them for 1 year, commencing with the date on which they receive a FIT payment. Please note, this condition affects both existing and new FIT generators. These changes came into effect on 1 July 2013 and should have been incorporated by FIT licensees in all Statement of FIT Terms (new and existing) by 1 October 2013.

### Application Dates for MCS-Certified Installations

A12.28. When a CoFPD is issued in relation to a FIT licensee, there may be applications for MCS-certified registration made to that FIT licensee that have not been assessed by it. Whilst the eligibility date for ROO-FIT installations is unaffected by a CoFPD, those for MCS-certified installations are dependent on the date the application was received by the failed FIT licensee. Article 24B of the FIT Order provides that in such cases FIT licensees must use the earlier dates of receipt by the failed FIT licensee of applications for MCS-certified registration, provided that there is evidence of receipt of the applications by the failed FIT licensee on those earlier dates.

A12.29. To preserve an eligible FIT installation's application date after a FIT licensee failure, the FIT generator should provide the new FIT licensee with evidence of the date their previous application was received by the failed FIT licensee. The new FIT licensee must honour this date and it should be entered on the CFR as the application date. Evidence of the

submission date could consist of; receipt emails, relevant documents on company headed paper (from the failed FIT licensee) or any evidence that a completed application was received.

## Appendix 13 – FIT licensee Request for Ofgem Investigation

A13.1. The below form should be used for the submission of information concerning issues relating to accredited FIT installations (see Chapter six for details).

### **FIT Licensee Request for Ofgem Investigation**

FIT licensees have an obligation to report any suspected abuse of the FIT scheme or inaccuracy regarding an accredited FIT installation. **FIT licensees can contact Ofgem through the submission of this form or, if this form is not appropriate for the situation then directly by phone, email or post.**

Please fill out this form and send to [FITRegister@ofgem.gov.uk](mailto:FITRegister@ofgem.gov.uk) if points 1, 2 or 3 set out below apply.

**1. There is *good reason* to believe that one of the following circumstances may apply with regard to the accredited FIT installation in question:**

- the decision to grant accreditation or preliminary accreditation was based on information which was incorrect in a material particular
- any condition attached to an accreditation (applied by Ofgem) has not been complied with
- the installation has been extended or modified in such a such a way that it would not be entitled to accreditation.

**2. There is *good reason* to suspect abuse of the FIT scheme by a FIT generator, in relation to the accredited FIT installation in question.**

**3. A FIT generator or nominated recipient may have received a FIT payment to which it was not entitled.**

Please refer to the “Feed-In Tariffs: Guidance for Licensed Electricity Suppliers” before submitting this form to us.

**Please note:**

- If fields are left blank or a detailed explanation is not provided the form may be returned to you for completion.
- Where the issue suspected involves **multiple accredited FIT installations** you may submit the information in a different format, but all information requested in this form should be included in your submission.
- We aim to respond to all emails within 5 working days. Due to the nature of the form you are submitting we will only respond initially to acknowledge receipt. If appropriate, we will contact you for further information and to notify you of any decision made in due course.

**Installation Details**

<b>FIT ID (including extension reference/s)</b>		<b>Technology type</b>	
<b>Accreditation number (MCS/RO/ROO-FIT)</b>		<b>TIC &amp; DNC (kW)</b>	
<b>Title and full name of FIT generator</b>		<b>Title and full name of payee/nominated recipient (if different)</b>	
<b>Generator Address</b>		<b>Installation Address</b>	

**Please confirm whether the total installed capacity is affected by the issue, or only part (ie just the original or extended capacity)**

Whole installation  Only part of the installation

**Reason(s) for Request**

**We [name of FIT licensee] have good reason to believe that the following situation has occurred with regard to the above detailed installation (Tick as appropriate) and would request that Ofgem review the matter further.**

- The decision to grant accreditation or preliminary accreditation was based on information which was incorrect in a material particular
- A condition attached to the accreditation has not been complied with
- An installation has been extended or modified in such a such a way that it would not be entitled to accreditation
- There is good reason to believe that abuse of the FIT scheme by the FIT generator has occurred.
- The FIT generator or nominated recipient has received a FIT payment to which it was not entitled
- Other

**Justification**

Please provide a detailed explanation of why it is believed that the above selected statement applies to the installation in question. Please include details.

**Evidence**

Please list below the evidence that is attached in support of the request being made.

Requests should be made via the **designated point of contact**.

**Signed:**

**Name:**

**Date:**

## Appendix 14 – Exiting the scheme – Written notification form

**Voluntary FIT Licensees who decide to withdraw their participation from the scheme may wish to use the form below for communicating their change in status to their portfolio of FIT generators**

Dear FIT Generator,

Please accept this letter as formal notification of [FIT Licensee's] decision to no longer participate in the Feed-in Tariff Scheme.

As of [dd/mm/yyyy], [FIT Licensee] will no longer be a FIT Licensee and any payments paid by [FIT Licensee] in relation to the FIT scheme will cease as of [dd/mm/yyyy].

[FIT Licensee] will continue to meet its obligations as a voluntary FIT Licensee in full until [dd/mm/yyyy].

In order to continue receiving FIT payments after this date, you must switch your installation to another FIT Licensee. To ensure you do not miss out on any payments, this should be done as soon as possible on receipt of this notification and the switch should be complete by [dd/mm/yyyy].

In order to switch licensees, you should approach the FIT Licensee of your choice and request a switch. [FIT Licensee] will then work together with your new licensee to agree a switch date.

Not all electricity suppliers are FIT Licensees. A list of current FIT Licensees can be found online at <https://www.ofgem.gov.uk/environmental-programmes/fit/electricity-suppliers/fit-licensees>.

Please note that switching is the responsibility of the generator and although [FIT Licensee] will work together with the new licensee in order to complete the switch in accordance with guidance from Ofgem, [FIT Licensee] will not initiate this process.

Kind Regards,

On behalf of [FIT Licensee]

## Appendix 15 – Quarterly Biennial Meter Verification Process

A15.1. FIT Licensees are required to take all reasonable steps to verify FIT meter readings of installations within two years from the confirmation date, for its initial meter read, or within two years of the last meter read.

A15.2. Where a FIT Licensee is unable to verify the meters at any FIT installations, they are required to notify Ofgem of these installations. This notification should be sent to [RECompliance@ofgem.gov.uk](mailto:RECompliance@ofgem.gov.uk) by last working day of the first month of each quarter ie 31 January, 30 April, 31 July and 31 October each year.

A15.3. Once the submission is reviewed, Ofgem may consider exercising its powers to further investigate the FIT Installation. We are able to switch the status of such installations to “under investigation” on the CFR and therefore withhold payments in bulk providing the submission is provided in the format set out below. where an installation has been placed ‘under investigation’ due to an overdue meter verification and has subsequently had its meter verified, we are able to return the status to ‘Normal’. In order to return the status to ‘Normal’, the meter inspection date must be updated. This should be done through the installation tab on the CFR under the ‘Update meter inspection dates’ function.

A15.4. Submissions should be in one spreadsheet, containing one tab for installations that require status changes to ‘Under Investigation’ and a separate tab for ‘Return to Normal’. Each tab should have the following column headers:

FIT ID	Extension ID	Reason
--------	--------------	--------

A15.5. Submissions that are not in the correct format will be returned to the FIT Licensee and not processed.

### **Timeline**

A15.6. Provided we receive the initial submission on time, in the correct format, and they pass our internal checks, we aim to process submissions within 20 working days (see the below timelines):



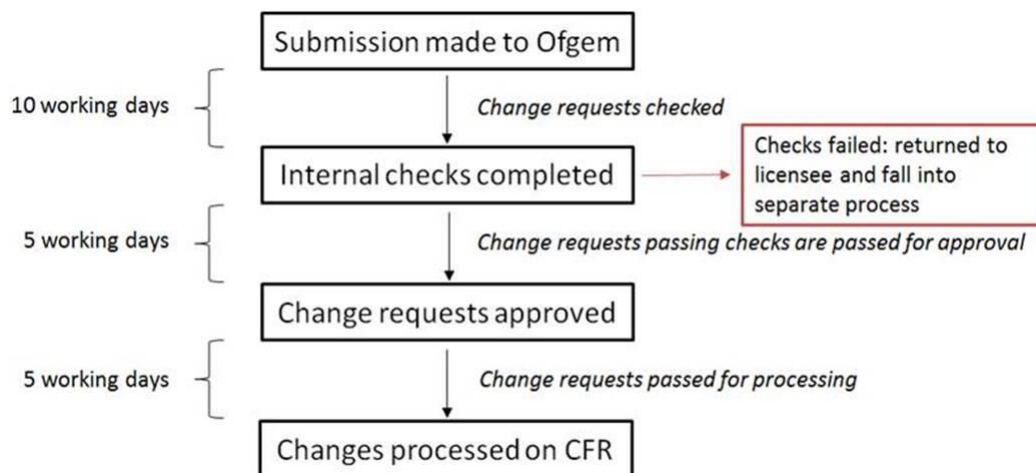

### **Ofgem Review**

A15.7. FIT Licensees should ensure that they have an appropriate set of checks in place prior to making a submission to help us to reduce and remove common errors, such as:

- Invalid FIT IDs
- Duplicate submission
- Installation already 'Under Investigation/'Normal'
- Meter inspection date not updated

A15.8. Submissions that fail our internal checks will be returned to the FIT Licensee, with commentary explaining our reasoning, and resolved via a separate process. Submissions that fall into this category can be returned to us for processing at the end of the first and second month of the quarter. Anything past this point should be resubmitted at the next bulk submission date.

A15.9. During this time no new requests should be added to the submission – these should be submitted within the following quarter's bulk submission.

**A15.10. The submission should be emailed to [RECompliance@ofgem.gov.uk](mailto:RECompliance@ofgem.gov.uk) by the last day of the first month of each quarter.**

## Appendix 16 – Glossary

All terms within this document shall have the same meaning as defined in Schedule A to Standard Condition 33 of the Electricity Supply Licence. Additionally, the following phrases shall have the meaning as listed below:

Affiliate	means in relation to an Electricity Supplier any holding company or subsidiary or subsidiary undertaking of a holding company of the licensee in each case within the meaning of the Companies Act 2006;
Application Date	The date, as applicable, of (i) receipt by the Authority of a FIT Generator’s written request for ROO-FIT Accreditation in a form acceptable to the Authority; or (ii) receipt by a FIT Licensee of a FIT Generator’s written request for MCS-certified Registration, accompanied by an MCS Certificate for the installation;
BSC	Balancing and Settlement Code
CCAB	Consultative Committee of Accountancy Bodies;
Central FIT Register	means the register kept and maintained by the Authority for the purpose of recording details of FIT Generators, Accredited FIT Installations and other such matters relating to the FIT Scheme
Community organisation	means a community interest company; or a community benefit society or co-operative society, or a charity other than such a company or society with less than 50 employees.
Declared net capacity	means the maximum capacity at which an installation can be operated for a sustained period without causing damage to it (assuming the source of power used by it to generate electricity was available to it without interruption) less the amount of electricity that is consumed by the Plant;
Degression	means the regular review and potential reduction of tariff rates for new installations based on deployment in the preceding months.
Deployment cap	means the set amount of capacity (Total Installed Capacity – TIC) that can apply to receive FIT support in a tariff period.

ECO	Energy Company Obligation, a legislative scheme imposed on Gas and Electricity Supply licence holders under the Energy Company Obligation Order 2012 S.I. 2012/3018
Education provider	means the owner of a building used as the premises of a qualifying educational institution; or a person or body responsible for the management of such an institution;
Eligible Installation	means any Plant on a Site which is capable of Small-scale Low-carbon Generation; and except as provided otherwise in the FIT Order all such Plant on the same Site which is capable of generating electricity from the same type of Eligible Low-carbon Energy Source is to be treated as a single Eligible Installation;
FIT Export	means Export or Deemed Export from an Accredited FIT Installation in relation to which a FIT Generator has requested to receive Export Payments in accordance with Part 1, clause 7.1 of the SLCs;
FIT Generator	means: <ul style="list-style-type: none"> <li>(a) in relation to an Accredited FIT Installation, the person identified as the Owner in the Central FIT Register; and</li> <li>(b) in relation to any other Eligible Installation, the Owner, whether or not that person is also operating or intending to operate the Eligible Installation;</li> </ul>
FIT Payments	means, as applicable, Generation Payments and/or Export Payments;
Implementation	means the date on which the FIT Scheme becomes operational;
LEC	Levy Exemption Certificate
Mandatory FIT Licensee	means a licensee which either: <ul style="list-style-type: none"> <li>supplies electricity to at least 250,000 domestic customers; or</li> <li>together with its Affiliates jointly supplies electricity to at least 250,000 domestic customers,</li> </ul> as at 31 December before the start of each FIT Year; and effective on and from the 1 April of the current FIT Year;

If a licensee ("licensee A") has zero domestic customers but its Affiliates supply electricity to at least 250,000 domestic customers, Licensee A will not be a mandatory FIT Licensee as it does not **jointly** supply electricity to at least 250,000 domestic customers.

MCS-certified Installation	means an Eligible Installation using an MCS-FIT Technology which has been recognised by MCS or equivalent as satisfying relevant equipment and installation standards;
MCS-certified Registration	means the process whereby an Eligible Installation confirmed as an MCS-certified Installation is entered onto the Central FIT Register by the Authority;
Migrated ROO generator	means a Generator whose installation was accredited under the ROO as at 1 April 2010 and has subsequently become an Accredited FIT Installation;
Multi-Site Generator	The reduced tariff rate, applicable from 1 April 2012 to any solar PV installation where the FIT Generator or nominated recipient already owns or receives FIT payments from 25 or more other eligible solar PV installations. This is subject to whether the energy efficiency requirement has also been met;
Nominated Recipient	means a person appointed by a FIT Generator to receive FIT Payments in respect of an Accredited FIT Installation owned by that FIT Generator and recorded as such on the Central FIT Register;
Principal FIT Licensee Terms	means the principal terms, to be included in the Statement of FITs Terms, which relate to the obligations which a FIT Generator must satisfy in order to receive FIT Payments from a FIT Licensee;
Principal Generator Terms	means the principal terms, to be included in the Statement of FIT Terms, which relate both to FIT Payments and the protection of FIT Generators;
Qualifying educational institution	means in England and Wales—

- i. a school within the meaning of section 4 of the Education Act 1996(a)<sup>83</sup>;
- ii. an institution within the further education sector, within the meaning of section 91(3) of the Further and Higher Education Act 1992(a)<sup>84</sup>; or
- iii. a 16 to 19 Academy within the meaning of section 1B of the Academies Act 2010(b)<sup>85</sup>;

in Scotland—

- i. a school within the meaning of section 135(1) of the Education (Scotland) Act 1980(c)<sup>86</sup>; or
- ii. a college of further education within the meaning of section 36(1) of the Further and Higher Education (Scotland) Act 1992(d)<sup>87</sup>;

**Renewables Obligation (RO)** means the Renewables Obligation Order 2009(d) in relation to an installation in England and Wales, and the Renewables Obligation (Scotland) Order 2009(e) in relation to an installation in Scotland;

**ROO-FIT Accreditation** means the process of accreditation pursuant to the FIT Order to be undertaken in respect of an Eligible Installation not using an MCS-FIT Technology;

**Stand-alone** An installation:  
not attached to a building and not wired to provide electricity to an occupied building [for eligible installations with a Tariff Date before 1 May 2013]; **or**

---

<sup>83</sup> 1996 c.56. Section 4 was amended by the Education Act 1997 (c.44), section 51 and Schedule 7, paragraph 10, the Education Act 2002 (c.32), Schedule 22, Part 3, the Childcare Act 2006 (c.21) section 95, the Education Act 2011 (c.21), Schedule 13, paragraph 9, and S.I. 2010/1080, Schedule 1, Part 2, paragraph 97.

<sup>84</sup> 1992 c.13. Section 91(3) was amended by the Apprenticeships, Skills, Children and Learning Act 2009 (c.22), Schedule 8, paragraph 13.

<sup>85</sup> 2010 c.32. Section 1B was inserted by the Education Act 2011 (c.21), section 53(7).

<sup>86</sup> 1980 c.44. The definition of "school" in section 135(1) was amended by the Registered Establishments (Scotland) Act 1987 (c.4), section 2(2), and the Standards in Scotland's Schools etc. Act 2000 (asp 6), Schedule 3.

<sup>87</sup> 1992 c.37.

not wired to provide electricity to a building [for eligible installations with a Tariff Date on or after 1 May 2013].

Tariff Date	<p>In relation to (a) an Eligible Installation for which the method of determining the Tariff Date is specified in the FIT Order, means the date as determined in the FIT Order;</p> <p>(b) an Eligible Installation whose Eligible Installation whose Eligibility Date is before 15 January 2016 means the Eligibility Date; or(c) an Eligible Installation whose Eligibility Date is on or after 8 February 2016, means the first day of the first Tariff Period within which the installation Qualifies for Accreditation.</p>
Tariff Period	<p>For micro CHP, means one of the following periods - (a) the period beginning on 1 April 2017 and ending on 30 September 2017; or (b) any subsequent period of 6 months beginning on 1 October or 1 April.</p> <p>For all other technologies, means one of the following periods - (a) the period beginning on 8 February 2016 and ending on 31 March 2016; (b) the period of 3 months beginning on 1 April 2016; or (c) any subsequent period of 3 months beginning on 1 July, 1 October, 1 January or 1 April.</p>
Total Installed Capacity	<p>means the maximum capacity at which an Eligible Installation could be operated for a sustained period without causing damage to it (assuming the Eligible Low-carbon Energy Source was available to it without interruption), a declaration of which is submitted as part of the processes of ROO-FIT Accreditation and MCS-certified Registration;</p>
Voluntary FIT Licensee	<p>means a licensee which is not a Mandatory FIT Licensee but which voluntarily elects to participate in making FIT Payments under the FIT Scheme.</p>
WHD	<p>Warm Home Discount</p>